

**HAIMER**<sup>®</sup>  
Quality Wins.

# BASIC MILL

Reduced to the essentials



[www.haimer-usa.com](http://www.haimer-usa.com)

- Straight shank (HA)
- Shank tolerance: h6
- Center cutting
- Unequal cutting edge
- Runout < 0.0004" (10 μm)



Characteristics	Application	Coolant

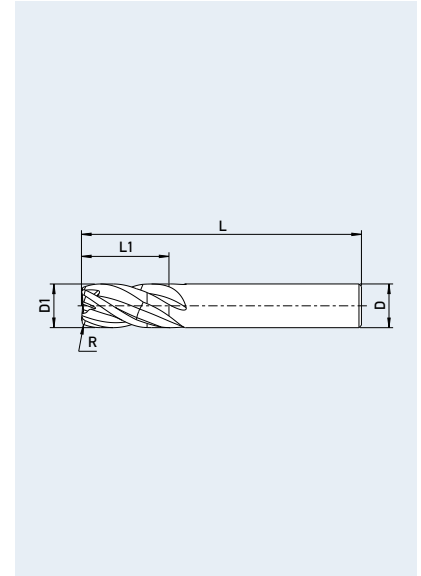

**Application Range - Material**

Main Material



also suitable for



- For almost all materials
- For roughing and finishing

- Drilling
- Slotting

- Ramping
- Cutting conditions see page 6

Cooling with Cool Jet or Cool Flash and using Power Chucks is recommended for higher tool life and increased metal removal rates.

Part Number	HAIMER Quality	D1 (f9) [in]	Cutting Edge [in]	Radius Size [in]	L1 [in]	L (+/- 0.04") [in]	D (h6) [in]	Shank
F2014NNH1/4ZR.015..	DA	1/4	R	0.015	7/16	2 1/2	1/4	HA
F2014NNH1/4ZR.030..	DA	1/4	R	0.030	7/16	2 1/2	1/4	HA
F2014LNH1/4ZR.015..	DA	1/4	R	0.015	3/4	2 1/2	1/4	HA
F2014LNH1/4ZR.030..	DA	1/4	R	0.030	3/4	2 1/2	1/4	HA
F2014LNH5/16ZR.015..	DA	5/16	R	0.015	13/16	2 1/2	5/16	HA
F2014LNH5/16ZR.030..	DA	5/16	R	0.030	13/16	2 1/2	5/16	HA
F2014KNH3/8ZR.030..	DA	3/8	R	0.030	1/2	2 1/2	3/8	HA
F2014NNH3/8ZR.030..	DA	3/8	R	0.030	7/8	2 1/2	3/8	HA
F2014KKH1/2ZR.015..	DA	1/2	R	0.015	5/8	2 1/2	1/2	HA
F2014KKH1/2ZR.030..	DA	1/2	R	0.030	5/8	2 1/2	1/2	HA
F2014NNH1/2ZR.030..	DA	1/2	R	0.030	1	3	1/2	HA
F2014NNH1/2ZR.060..	DA	1/2	R	0.060	1	3	1/2	HA
F2014NLH1/2ZR.015..	DA	1/2	R	0.015	1 1/4	3 1/2	1/2	HA
F2014NLH1/2ZR.030..	DA	1/2	R	0.030	1 1/4	3 1/2	1/2	HA
F2014NLH1/2ZR.060..	DA	1/2	R	0.060	1 1/4	3 1/2	1/2	HA
F2014NNH5/8ZR.030..	DA	5/8	R	0.030	1 1/4	4	5/8	HA
F2014NNH5/8ZR.060..	DA	5/8	R	0.060	1 1/4	4	5/8	HA
F2014NNH3/4ZR.030..	DA	3/4	R	0.030	1 1/2	4	3/4	HA
F2014NNH3/4ZR.060..	DA	3/4	R	0.060	1 1/2	4	3/4	HA
F2014NNH3/4ZR.090..	DA	3/4	R	0.090	1 1/2	4	3/4	HA
F2014NNH3/4ZR.125..	DA	3/4	R	0.125	1 1/2	4	3/4	HA

Order code = Part number + HAIMER Quality.

# BASIC MILL Z4

## F2014 RADIUS WITH SAFE-LOCK® SHANK

### TECHNICAL DATA AND PRODUCT CHARACTERISTICS

INCH



- Safe-Lock™ (Shank S-λ)
- Shank tolerance: h6
- Center cutting
- Unequal cutting edge
- Runout < 0.0004" (10 μm)



Characteristics	Application	Coolant

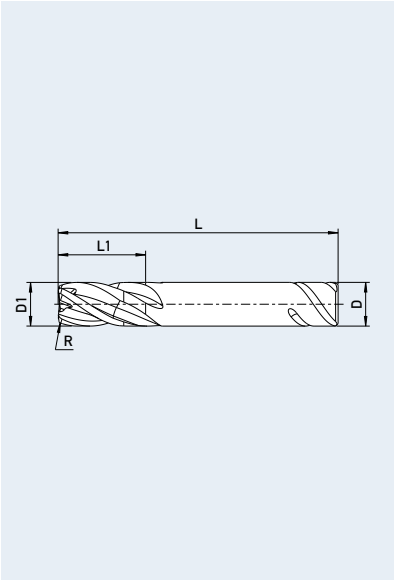

**Application Range - Material**

**Main Material**

**also suitable for**

P
M
K
S
N

- For almost all materials
- For roughing and finishing
- Drilling
- Slotting
- Ramping
- Cutting conditions see page 6

Cooling with Cool Jet or Cool Flash and using Power Chucks is recommended for higher tool life and increased metal removal rates.

Part Number	HAIMER Quality	D1 (f9) [in]	Cutting Edge [in]	Radius Size [in]	L1 [in]	L (+/- 0.04") [in]	D (h6) [in]	Shank
F2014NNL1/2ZR.030..	DA	1/2	R	0.030	1	3	1/2	S-λ
F2014NNL1/2ZR.060..	DA	1/2	R	0.060	1	3	1/2	S-λ
F2014NLL1/2ZR.015..	DA	1/2	R	0.015	1 1/4	3 1/2	1/2	S-λ
F2014NLL1/2ZR.030..	DA	1/2	R	0.030	1 1/4	3 1/2	1/2	S-λ
F2014NLL1/2ZR.060..	DA	1/2	R	0.060	1 1/4	3 1/2	1/2	S-λ
F2014NNL5/8ZR.030..	DA	5/8	R	0.030	1 1/4	4	5/8	S-λ
F2014NNL5/8ZR.060..	DA	5/8	R	0.060	1 1/4	4	5/8	S-λ
F2014NNL3/4ZR.030..	DA	3/4	R	0.030	1 1/2	4	3/4	S-λ
F2014NNL3/4ZR.060..	DA	3/4	R	0.060	1 1/2	4	3/4	S-λ
F2014NNL3/4ZR.090..	DA	3/4	R	0.090	1 1/2	4	3/4	S-λ
F2014NNL3/4ZR.125..	DA	3/4	R	0.125	1 1/2	4	3/4	S-λ

SAFE-LOCK®

Order code = Part number + HAIMER Quality.

- Straight shank (DIN 6535-HA)
- Shank tolerance: h6
- Necked for longer reach
- Center cutting
- Unequal cutting edge
- Runout < 0.0004" (10 µm)



Characteristics	Application	Coolant

**Application Range - Material**

Main Material



also suitable for



- For almost all materials
- For roughing and finishing

- Drilling
- Slotting

- Ramping
- Cutting conditions see page 7

Cooling with Cool Jet or Cool Flash and using Power Chucks is recommended for higher tool life and increased metal removal rates.

Part Number	HAIMER Quality	D1 (f9) [mm]	Cutting Edge	Chamfer Size [mm]	L1 max. [mm]	L(+/-1) [mm]	L2 [mm]	D2 [mm]	D (h6) [mm]	Shank
F2004NNH0200C..	DA	2.00	C	0.04	7	58	9	1.9	6	HA
F2004NNH0300C..	DA	3.00	C	0.06	8	58	10	2.9	6	HA
F2004NNH0400C..	DA	4.00	C	0.08	11	58	15	3.8	6	HA
F2004NNH0500C..	DA	5.00	C	0.10	13	58	18	4.8	6	HA
F2004NNH0600C..	DA	6.00	C	0.12	13	58	20	5.7	6	HA
F2004NNH0800C..	DA	8.00	C	0.16	19	64	26	7.6	8	HA
F2004NNH1000C..	DA	10.00	C	0.20	22	73	30.5	9.5	10	HA
F2004NNH1200C..	DA	12.00	C	0.24	26	84	36.5	11.4	12	HA
F2004NNH1400C..	DA	14.00	C	0.28	26	84	36.5	13.3	14	HA
F2004NNH1600C..	DA	16.00	C	0.32	32	93	42.5	15.2	16	HA
F2004NNH1800C..	DA	18.00	C	0.36	32	93	42.5	17.1	18	HA
F2004NNH2000C..	DA	20.00	C	0.40	38	105	52	19	20	HA

Order code = Part number + HAIMER Quality.

# BASIC MILL Z4

## F2004>NNL CHAMFER WITH SAFE-LOCK® SHANK

### TECHNICAL DATA AND PRODUCT CHARACTERISTICS

METRIC

**HAIMER**  
Quality Wins.

- Safe-Lock™ (Shank S-λ)
- Shank tolerance: h6
- Necked for longer reach
- Center cutting
- Unequal cutting edge
- Runout < 0.0004" (10 μm)



#### Characteristics



#### Application



#### Coolant

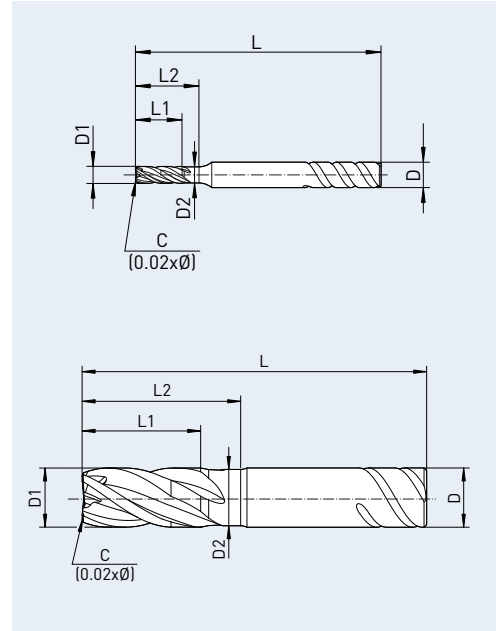

#### Application Range - Material

Main Material



also suitable for



- For almost all materials
- For roughing and finishing

- Drilling
- Slotting

- Ramping
- Cutting conditions see page 7

Cooling with Cool Jet or Cool Flash and using Power Chucks is recommended for higher tool life and increased metal removal rates.

Part Number	HAIMER Quality	D1 (F9) [mm]	Cutting Edge	Chamfer Size [mm]	L1 max. [mm]	L(+/-1) [mm]	L2 [mm]	D2 [mm]	D (h6) [mm]	Shank
F2004>NNL0200C..	DA	2.00	C	0.04	7	58	9	1.9	6	S-λ
F2004>NNL0300C..	DA	3.00	C	0.06	8	58	10	2.9	6	S-λ
F2004>NNL0400C..	DA	4.00	C	0.08	11	58	15	3.8	6	S-λ
F2004>NNL0500C..	DA	5.00	C	0.10	13	58	18	4.8	6	S-λ
F2004>NNL0600C..	DA	6.00	C	0.12	13	58	20	5.7	6	S-λ
F2004>NNL0800C..	DA	8.00	C	0.16	19	64	26	7.6	8	S-λ
F2004>NNL1000C..	DA	10.00	C	0.20	22	73	30.5	9.5	10	S-λ
F2004>NNL1200C..	DA	12.00	C	0.24	26	84	36.5	11.4	12	S-λ
F2004>NNL1400C..	DA	14.00	C	0.28	26	84	36.5	13.3	14	S-λ
F2004>NNL1600C..	DA	16.00	C	0.32	32	93	42.5	15.2	16	S-λ
F2004>NNL1800C..	DA	18.00	C	0.36	32	93	42.5	17.1	18	S-λ
F2004>NNL2000C..	DA	20.00	C	0.40	38	105	52	19	20	S-λ



SAFE-LOCK®

Order code = Part number + HAIMER Quality.

Material Groups	Work Material	Material Information	Content/ Hardness	Depths of Cut			
				ap = 100% D1 ae = 1 x D1	ap = 15% D1 ae = L1 max.	ap = 5% D1 ae = L1 max.	
	ANSI	Tensile Strength		Cutting Speed (SFM)			
P1	Carbon and Mild Steels	1015, 1045, 4140, 4340	≤ 116,000 PSI, 800 MPA	up to 25 HRC	840 – 900	1050 – 1120	1310 – 1380
P2	Heat Treated Steels	D2, A2, H13, S7	> 116,000 PSI, 800 MPA	up to 45 HRC	620 – 690	720 – 790	950 – 1020
M1	Stainless Steels	303, 304,	≤ 94,275 PSI, 650 MPA		310 – 360*	380 – 440	490 – 560
M2	Stainless Steels	17-4PH, 15-5PH, 316L	> 94,275 PSI, 650 MPA		250 – 290*	310 – 340	360 – 430
K1	Cast Iron	ASTM A48 NO. 30, ASTM A48 NO. 55/60, G1800	≤ 65,265 PSI, 450 MPA		520 – 590	590 – 660	690 – 750
K2	Ductile Cast Iron	ASTM A536 80-55-06, ASTM A536 100-70-03	> 65,265 PSI, 450 MPA		430 – 490	490 – 560	590 – 660
S1	Titanium & Titanium Alloys	B265, B338, B348, Ti6AL4V			160 – 200*	200 – 260	260 – 300
N1	Aluminum Alloys	A5005, A6061, A7075			1540 – 1610	1970 – 2070	2560 – 2690
N2	Cast Aluminum Alloys	A310, A400		Si > 12%	1120 – 1180	1380 – 1440	1770 – 1900

Cutting data are reference values and need to be adjusted according to the application. Chip removal recommended from drilling depth 0.5 – 1 x D.

Feed per tooth (in/tooth) in relation with D and cutting width ae							
ae	1/4"	5/16"	3/8"	1/2"	5/8"	3/4"	
to 50% ø	0.0013	0.0019	0.0025	0.003	0.0036	0.0039	
to 100% ø	0.001	0.0015	0.0022	0.0024	0.0033	0.0037	

Part Entry								
Method	Material	max. Entry Angle	Feed per Tooth (in/tooth)					
			1/4"	5/16"	3/8"	1/2"	5/8"	3/4"
 Plunging*	P1		0.0008	0.0012	0.0016	0.0018	0.0020	0.0023
	P2		0.0004	0.0006	0.0010	0.0012	0.0014	0.0016
	K1		0.0008	0.0012	0.0016	0.0018	0.0020	0.0023
	N1		0.0008	0.0012	0.0016	0.0018	0.0020	0.0023
	N2		0.0004	0.0006	0.0010	0.0012	0.0014	0.0016
 Ramping*	P1	45°	0.0008	0.0012	0.0017	0.0019	0.0021	0.0024
	P2	30°	0.0006	0.0006	0.0009	0.0012	0.0014	0.0016
	M1	10°	0.0004	0.0006	0.0010	0.0012	0.0014	0.0016
	M2	5°	0.0004	0.0005	0.0007	0.0009	0.0018	0.0014
	K1	45°	0.0009	0.0012	0.0016	0.0018	0.0020	0.0024
	K2	20°	0.0006	0.0009	0.0013	0.0016	0.0017	0.0020
	S1	10°	0.0005	0.0006	0.0008	0.0010	0.0012	0.0014
	N1	30°	0.0008	0.0012	0.0017	0.0019	0.0021	0.0025
	N2	30°	0.0006	0.0006	0.0009	0.0012	0.0014	0.0016

\*For Slotting (100% ø) in material M1, M2 and S1 reduce feed per tooth by 30%.

\*For Ramping in material M1, M2, reduce SFM by 40%, for K2 reduce SFM by 10%.

\*For Plunging, reduce all SFM by 40%.



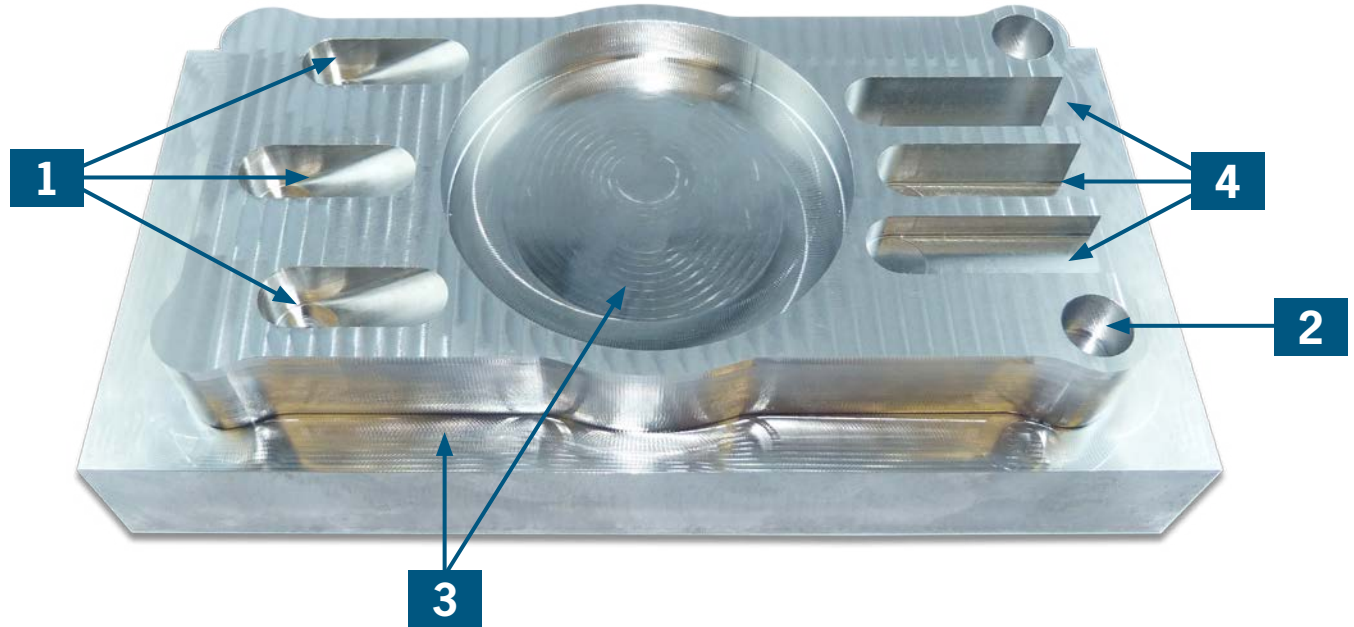

**Universal applications of Basic Mill in 42CrMo4**

The 42CrMo4 steel workpiece with tensile strength of 104,427 PSI is machined within 1 min and 41 sec.

All applications (ramping, drilling, trochoidal milling and slotting) were done by Basic Mill F2014NNH120OCDA in diam. 12 mm.

**Universality is no problem for Basic Mill!**

The workpiece was clamped with a mechanical bench vice. During the milling operation air was blown through the spindle nozzles for cooling.



See the Basic Mill in Action!

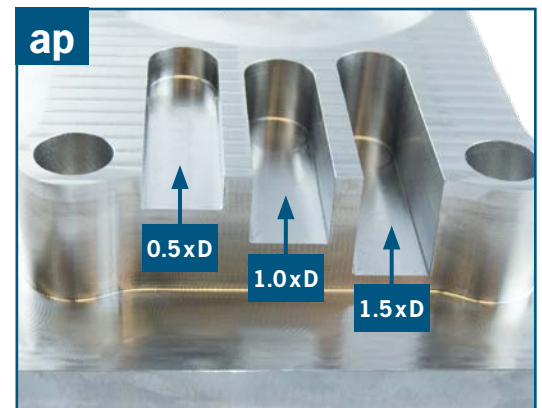

**Application:**  
**Ramping 30°**

Cutting Speed (SFM): 656  
Feed per tooth fz: 0.0012"  
Cutting width ae: 0.472"  
Cutting depth ap: 0.472"



**Application:**  
**Drilling 1 x D**

Cutting Speed (SFM): 656  
Feed per tooth fz: 0.0012"  
Cutting width ae: 0.472"  
Cutting depth ap: 0.472"

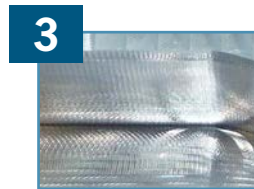

**Application:**  
**Trochoidal Milling**

Cutting Speed (SFM): 1411  
Feed per tooth fz: 0.0073"  
Cutting width ae: 0.094"  
Cutting depth ap: 0.827"



**Application:**  
**Slotting 0.5 – 1.5xD**

Cutting Speed (SFM): 656  
Feed per tooth fz: 0.0019"  
Cutting width ae: 0.472"  
Cutting depth ap: up to 0.709"