



EMUGE

High Performance Tools
Threading Technology · Clamping Technology



Thread Cutting Technology · Clamping Technology

CATALOG 520

Welcome to our **EMUGE Catalog 520**. Let our new catalog be your guide on a trip to the very leading edge of thread cutting technology and into the twenty-first century!

At **EMUGE** we are dedicated to exhaustive research and development, product manufacturing excellence, and unsurpassed customer service. We have introduced more new and innovative products recently than ever before in our history. These, in combination with our standard lines, comprise the most comprehensive and technologically advanced thread and cutting tool product line in the world.

EMUGE Tools are designed and engineered for use today... and in future. Whether your application requirements are general purpose or high tech, we can find the right thread cutting solution for you.

We can recommend the appropriate tool, monitor initial product tests, provide installation assistance, and offer product support services through-out our relationship with you. That promises to be a very long time because our customer relationship tend to be a long term. We're proud of that.



*We have a slogan —
EMUGE Finds Success In Yours.
Let's work together for that success.*

Changes of any kind, or printing errors regarding technical details, do not justify any claims. All pictures are without obligation. Reprinting of text or pictures, or extracts thereof, is not allowed without our prior permission.

EMUGE Corp.

1800 Century Drive · West Boylston, MA 01583-2121
(508)-595-3600 Phone · (508) 595-3650 Fax · (800) 323-3013 Toll Free

www.emuge.com · emuge@emuge.com

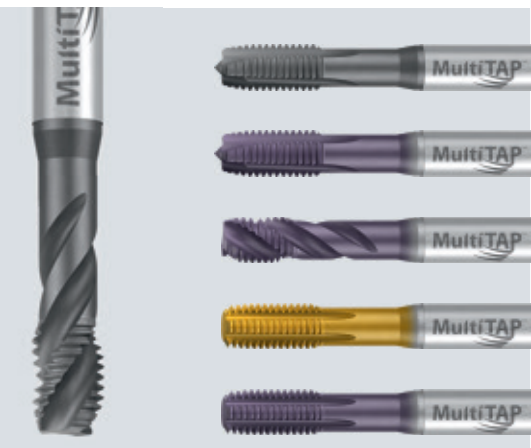
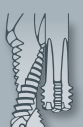
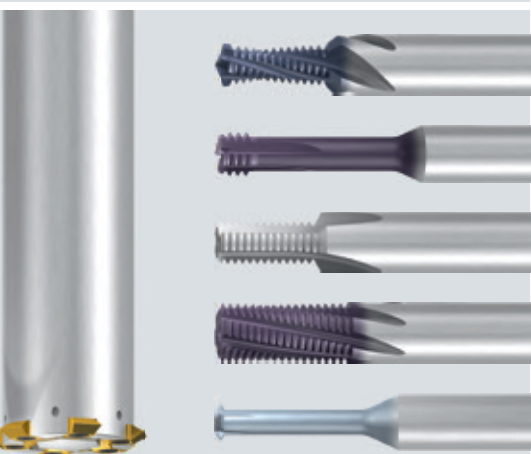
	<p>1</p>	<p>Taps</p> <p>9 - 162</p>	
	<p>2</p>	<p>Roll Form Taps</p> <p>163 - 210</p>	
	<p>3</p>	<p>MultiTAP™</p> <p>211 - 226</p>	
	<p>4</p>	<p>Thread Mills</p> <p>227 - 362</p>	



Twist Drills

5

363 - 428

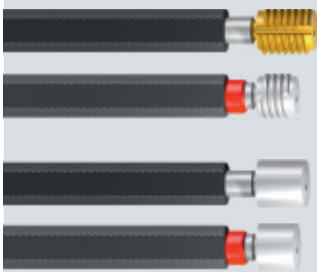

Thread Gages

6

429 - 476



Tap Holders and Tapping Attachments

7

477 - 650

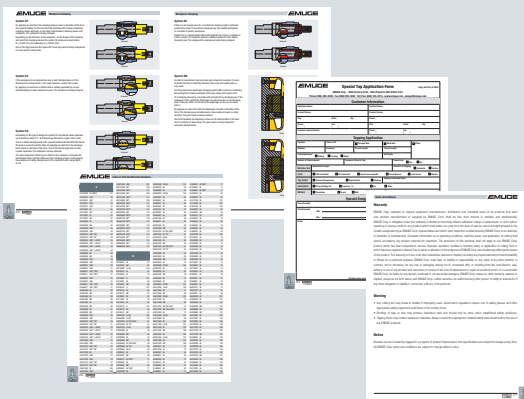
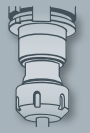

General Information

8

651 - 671



The EMUGE Punch Tap for thread production in Aluminum and similar materials is a faster alternative for mass production environments. Thanks to its innovative, very short motion process, it establishes an entirely new dimension of productivity.

A comparison between the tool path of the EMUGE Punch Tap with the tool path of conventional taps or roll form taps shows that the path of the Punch Tap is approximately 15 times shorter for a thread M6 with thread depth of 15 mm.

The result is a significant time savings of up to 75% in a threading cycle.

Contact Emuge for more information about this revolutionary concept.



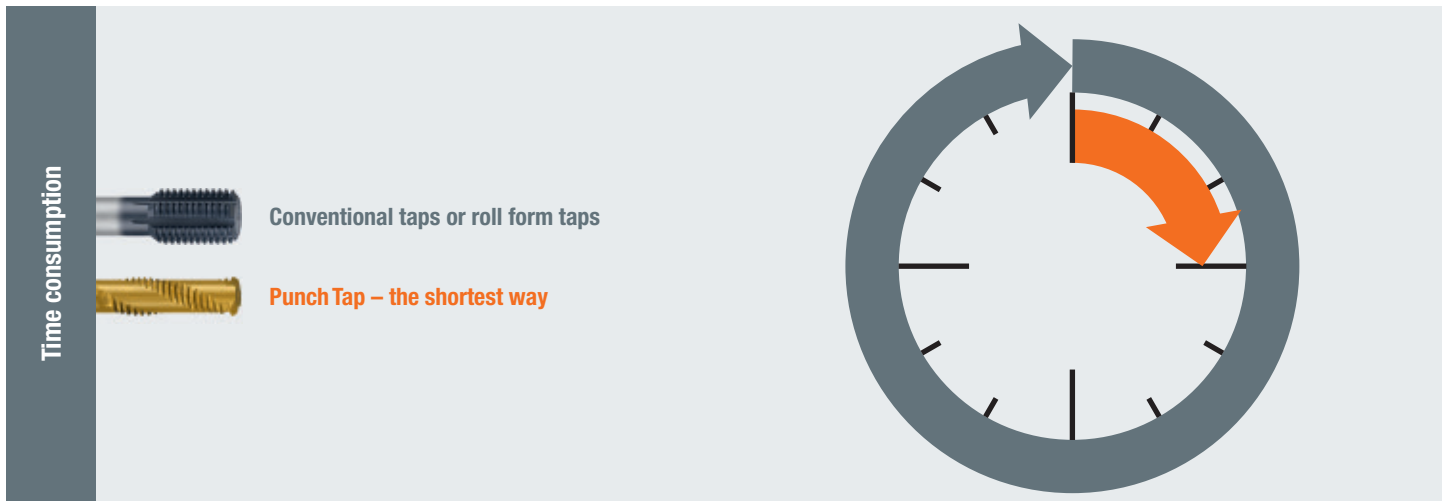
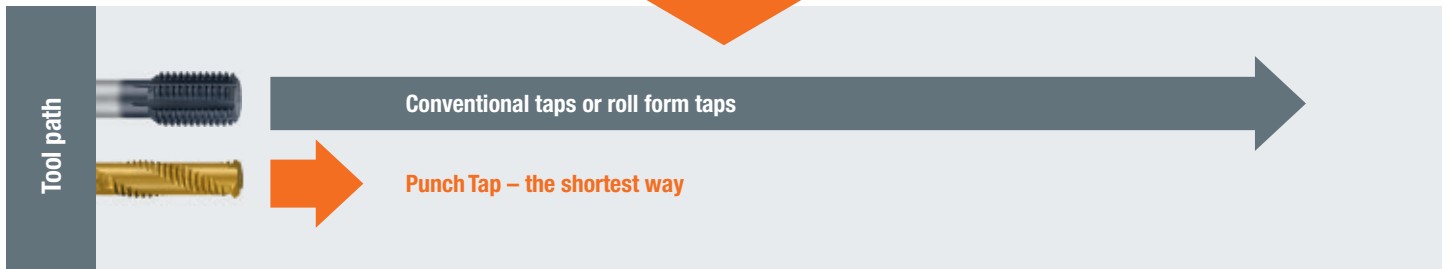
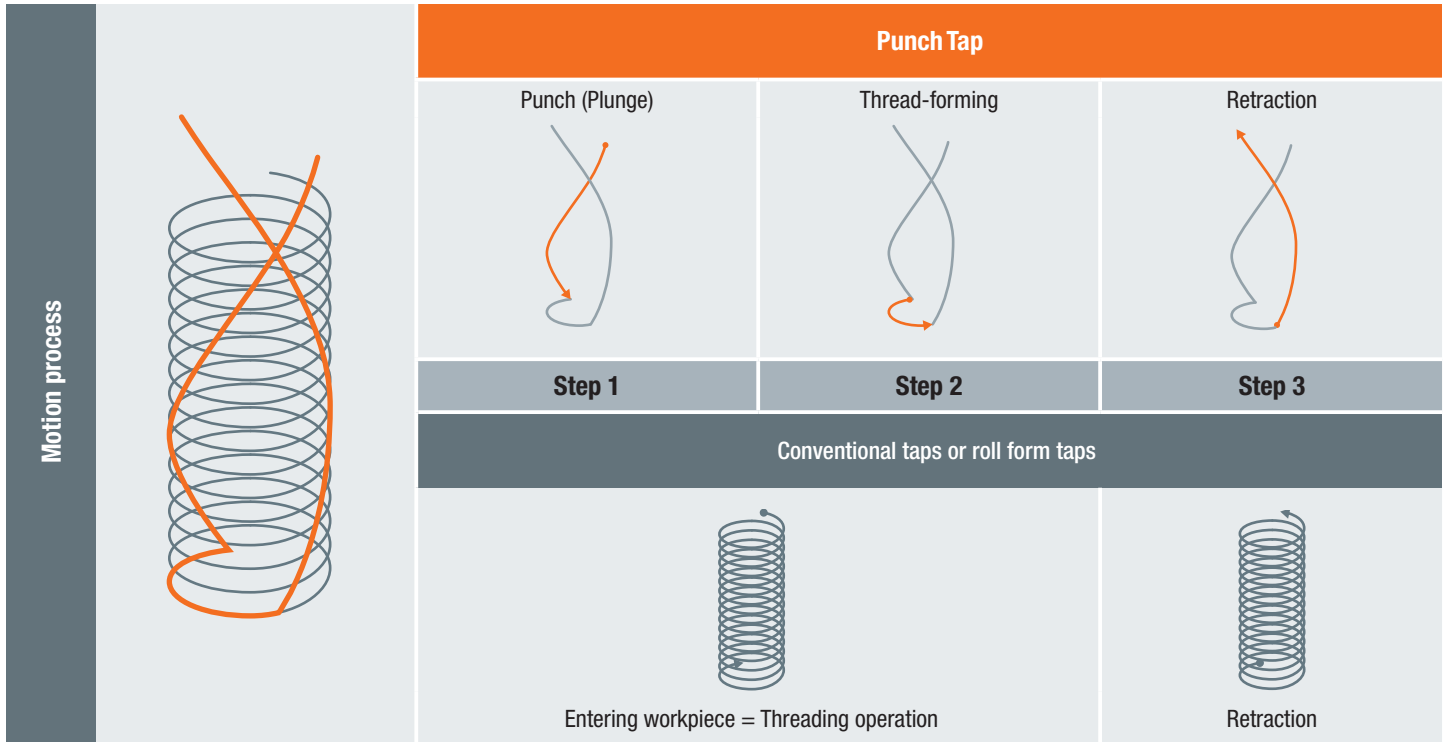

Result The EMUGE Punch Tap achieves a time saving of up to 75% in a threading cycle thanks to its shorter tool paths.

American units into SI units			SI units into American units		
Length					
1 inch (in)	= 25.4 mm	= 2.54 cm	1 millimeter (mm)	= 0.03937 in	
1 foot (ft)	= 12 in	= 0.3048 m	1 centimeter (cm)	= 10 mm	= 0.3937 in
1 yard (yd)	= 3 ft	= 0.9144 m	1 meter (m)	= 100 cm = 3.2808 ft = 1.0936 yd	
1 statute mile	= 1760 yd	= 1.60934 km	1 kilometer (km)	= 1000 m	= 0.62137 statute mile
Area					
1 in ²	= 645.16 mm ²	= 6.4516 cm ²	1 mm ²	= 0.00155 in ²	
1 ft ²	= 144 in ²	= 0.0929 m ²	1 cm ²	= 100 mm ²	= 0.155 in ²
1 yd ²	= 9 ft ²	= 0.8361 m ²	1 m ²	= 10000 cm ² = 10.7642 ft ² = 1.196 yd ²	
1 mile ²		= 2.590 km ²	1 km ²	= 10 ⁶ m ²	= 0.3861 mile ²
Volume					
1 in ³	= 16387.064 mm ³	= 16.387 cm ³	1 mm ³	= 0.000061 in ³	
1 ft ³	= 1728 in ³	= 0.0283 m ³	1 cm ³	= 1000 mm ³	= 0.0610 in ³
1 yd ³	= 27 ft ³	= 0.765 m ³	1 m ³	= 10 ⁶ cm ³ = 35.3146 ft ³ = 1.3080 yd ³	
1 Quart / US	= 1/4 gal	= 0.946 l	1 Liter (l)	= 1 dm ³ = 0.2642 gal / US = 2.11 US pt	
1 gallon (gal) / US	= 4 quarts	= 3.784 l	1 l	= 1.761 UK pt	
1 gallon (gal) / UK		= 4.546 l			
1 US pint (pt)	= 0.8327 UK pt	= 0.473 l			
1 UK pt	= 1.201 US pt	= 0.568 l			
1 barrel / US (Oil)	= 42 gal	= 158.98 l			
1 barrel / UK	= 36 gal	= 163.66 l			
Weight					
1 ounce (oz)	= 16 drams	= 28.35 g	1 gram (g)	= 0.03527 oz	
1 pound (lb)	= 16 oz	= 453.592 g	1 kilogram (kg)	= 1000 g	= 2.20462 lb
1 short ton / US		= 0.907 t	1 ton (t)	= 1000 kg	= 1.1025 short tons / US
1 long ton / UK		= 1.016 t	1 ton (t)	= 1000 kg	= 0.984 long tons / UK
Force					
1 pound force (lbf)	= 4.448 N		1 Newton (N)	= 0.2248 lbf	
Pressure/Tensile strength					
1 lbf/ft ²		= 47.8803 Pa	1 Pascal (Pa)	= 10 ⁶ N/mm ²	= 0.02089 lbf/ft ²
1 lbf/in ²	= 6.89476 kPa	= 6.895 · 10 ⁻³ N/mm ²	1 N/mm ²	= 0.1 bar	= 145 psi
1 psi (pound-force per sq.in)	= lbwt/in ²	= 6.895 · 10 ⁻³ N/mm ²	1 bar	= 10 N/mm ²	= 14.5 psi
1 psi		= 6.895 · 10 ⁻² bar			
Power					
1 foot-pounds per second (ft lb/s)		= 1.356 W	1 Watt (W)	= 1 J/s = 1 Nm/s	= 0.7376 ft lb/s
Energy/Torque					
1 foot pound-force (ft-lbf)		= 1.356 J	1 Joule (J)	= 1 Nm	= 0.7376 ft lb
Cutting/Circumferential speed					
1 surface feet per minute (SFM)		= 0.3048 m/min	1 m/min		= 3.2808 SFM
Cutting/Circumferential speed					
in degree Fahrenheit (°F)		= 9/5 Temp.[°C]+32	in degree Celsius (°C)		= (Temp.[°F]-32) · 5/9



Taps

	Page
Contents	10 - 13
Product Finder and Cutting Data	14 - 21
Product Pages	22 - 140
Technical Information	141 - 162

Product Finder

- V_c
- UNC
- UNF
- UNEF
- UN-8
- M
- MF
- NPSM/NPSC
- NPSF
- Rp (BSPP)
- G
- NPT
- NPTF
- Rc (BSPT)
- STI
- SELF-LOCK
- Accessories
- Tech. Info



Taps with reinforced shank		Taps with reduced shank		Taps with internal chip collector	
Rekord 1 Enorm 1		Rekord 2 Enorm 2		Robust 2X	
DIN Length ANSI Shank	DIN Length DIN Shank	DIN Length ANSI Shank	DIN Length DIN Shank	DIN Length ANSI Shank	DIN Length DIN Shank

	Page					
UNC	22 - 32		22 - 32		33	
UNF	38 - 48		38 - 48		49	
UNEF				54		
UN-8			55 - 57		58	
M		59 - 75		59 - 75		76
MF		82 - 92		82 - 92		93 - 94
NPSM/NPSC				98		
NPSF				99		
Rp (BSPP)				100		
G		101		102 - 105		106
NPT						
NPTF						
Rc (BSPT)						
STI-UNC	119 - 120		119 - 120			
STI-UNF	121 - 123		121 - 123			
STI-M		124 - 125		124 - 125		
LK-UNC	126 - 127		126 - 127			
LK-UNF	128		128			
LK-M		129 - 130		129 - 130		

	Page
Taper Reamers 1:16 For tapered threads	118
Tapping Fluid	131

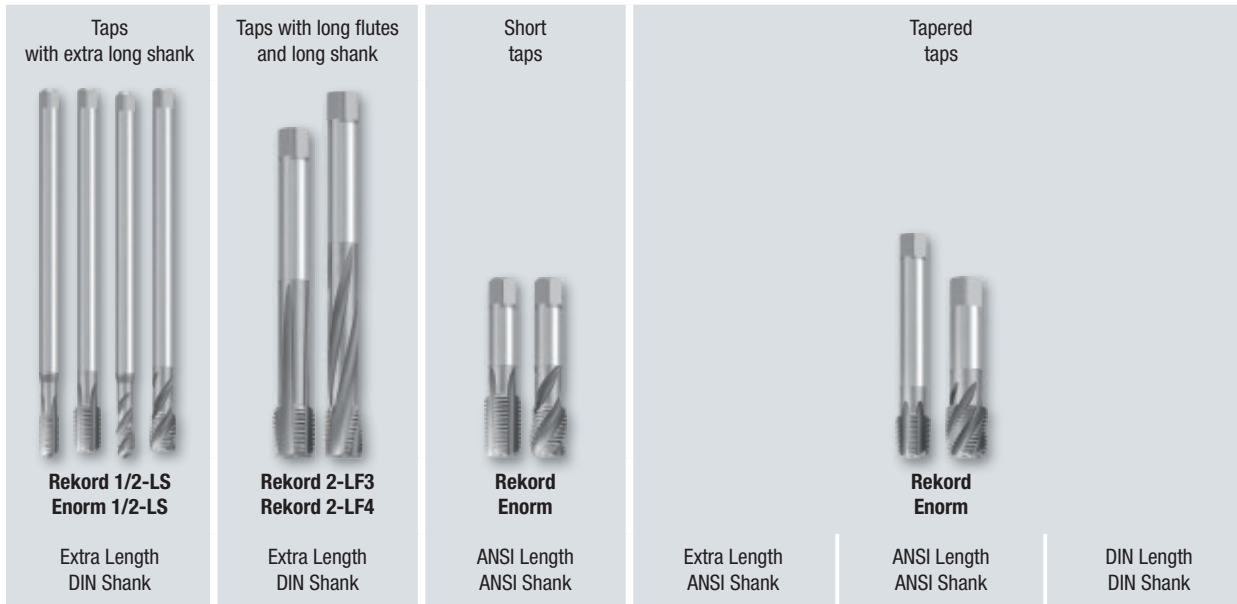

Page

		34 - 37				UNC
		50 - 53				UNF
						UNEF
						UN-8
78 - 79	77	80 - 81				M
	95	96 - 97				MF
						NPSM/NPSC
						NPSF
						Rp (BSPP)
						G
			107 - 108	109 - 111		NPT
			112	113 - 115		NPTF
					116 - 117	Rc (BSPT)
						STI-UNC
						STI-UNF
						STI-M
						LK-UNC
						LK-UNF
						LK-M

- Product Finder**
- Vc
 - UNC
 - UNF
 - UNEF
 - UN-8
 - M
 - MF
 - NPSM/NPSC
 - NPSF
 - Rp (BSPP)
 - G
 - NPT
 - NPTF
 - Rc (BSPT)
 - STI
 - SELF-LOCK
 - Accessories
 - Tech. Info



<p>Special Shank Extensions and Accessories</p>	<p>Page</p> <p>132 - 140</p>
<p>EF-Drill C – Chamfer Drills 90°</p>	<p>412</p>

EMUGE Taps with Special Tolerance

- Product Finder
- V_c
- UNC
- UNF
- UNEF
- UN-8
- M
- MF
- NPSM/NPSC
- NPSF
- Rp (BSPP)
- G
- NPT
- NPTF
- Rc (BSPT)
- STI
- SELF-LOCK
- Accessories
- Tech. Info

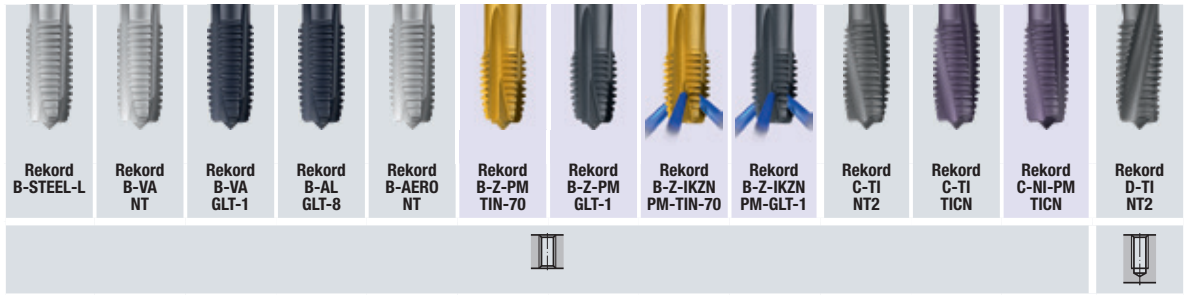

Page

UNC	3B		34	23										
	3BX					25		28			25, 35	25	26	25, 35
	Override		34	23										
UNF	3B		50	39										
	3BX					41		44			41, 51	41	42	41, 51
	Override		50	39										
UN-8	3B													
	3BX													
M	ISO 3/6G	59	61											
	6GX						71	71	71	71				
	7G	59	61											
MF	ISO 3/6G	82												
STI-UNC	3B		119	119	119									
	3BX													120
STI-UNF	3B		121	121	121									
	3BX													122

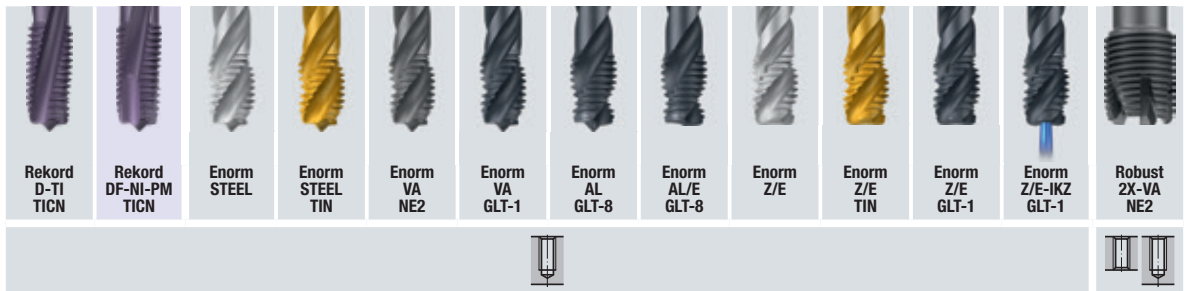

Page

UNC	3B			22		23, 35	23	24		37	37	30	31	
	3BX	25	26											33
	Override					35	24							
UNF	3B			38		39, 51	39	40		53	53	46	47	
	3BX	41	42											49
	Override					51	40							
UN-8	3B					55	55							
	3BX													58
M	ISO 3/6G			60	61						73			
	6GX													
	7G			61	61									
MF	ISO 3/6G										91			
STI-UNC	3B								119	120	120	120		
	3BX													
STI-UNF	3B								121	123	123	123		
	3BX		122											

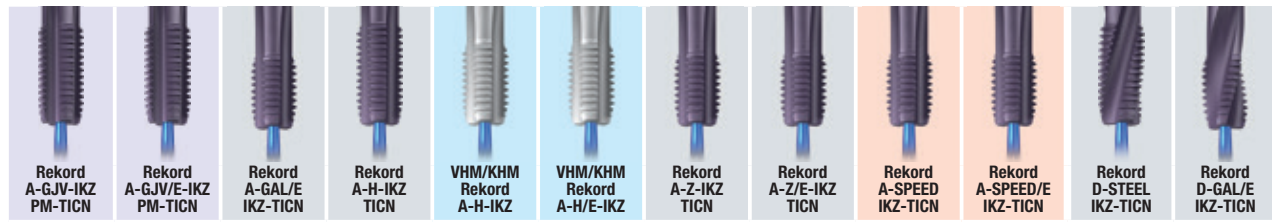

Page

			27			27	27	31	31	22		UNC
			43			43	43	47	47	38		UNF
63	63	64	67	67		70, 77	70	74	74		64	M
84	84		85	85		88, 95	88	91	91			MF
					104							G



Page

	29		29		32	29		30	30, 31	32		UNC
	45		45		48	45		46	46, 47	48		UNF
			57									UN-8
65	72, 77		72, 77	72		73	73				75	M
	89, 95	89	89, 95	90			90				92	MF

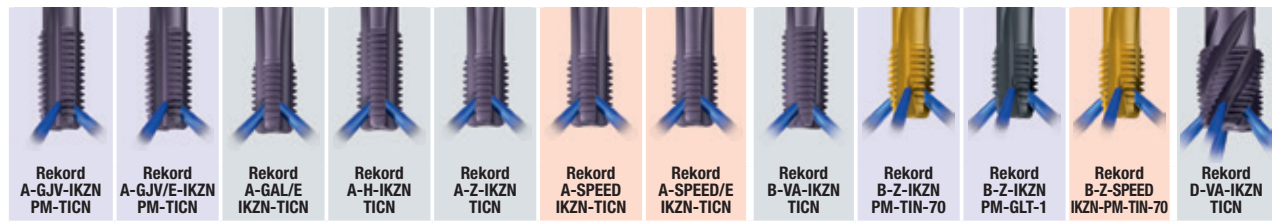

Page

				27	31			23	28		31		UNC
				43	47			39	44		47		UNF
63	63	64	67	70	74	74			71	71	75		M
84	85		85	88	91	91			89	89	91		MF
												110	NPT
												114	NPTF

Fold-Out Page

This fold-out page is intended to be a guide to the diverse application ranges, organized according to material groups.

Product finder and cutting data

Please note:

The cutting speeds (v_c in SFM) listed in the respective columns are standard values which have to be adjusted to individual work conditions (material, lubrication, machine etc.).

The suitability is marked as follows:

- Preferred suitable tap
- Suitable tap

Wavy line symbol = DIN form / threads (chamfer length)

Product finder table showing tap types (Rekord A-STEEL, B-STEEL-L, etc.), thread depth and hole types, and cutting speed ranges for various materials.

Main application table with columns for Application - Material, Hardness Range (HRC, BHN, N/mm2), and Material Examples, categorized by material groups like Steel, Stainless steel, Cast, Non ferrous, and Hard materials.

EMUGE
VA

EMUGE
GG

EMUGE
GJV



Rekord B-VA TiCN	Rekord B-VA-IKZN TiCN	Enorm VA	Enorm VA NE2	Enorm VA GLT-1	Robust 2X-VA NE2	Rekord A-GG NT	Rekord A-GJV PM-TiCN	Rekord A-GJV-IKZ PM-TiCN	Rekord A-GJV-IKZN PM-TiCN	Rekord A-GJV/E PM-TiCN	Rekord A-GJV/E-IKZ PM-TiCN	Rekord A-GJV/E-IKZN PM-TiCN		
B / 4-5	B / 4-5	C / 2-3	C / 2-3	C / 2-3	C / 2-3	C / 2-3	C / 2-3	C / 2-3	C / 2-3	E / 1.5-2	E / 1.5-2	E / 1.5-2		
max. 3 x d ₁		max. 2.5 x d ₁			max. 1.5 x d ₁		max. 2 x d ₁		max. 2 x d ₁		max. 2 x d ₁		max. 2 x d ₁	
55	23 39	62, 79, 81 97	23, 35 39, 51 55 62 83	23, 24 39, 40 55 62, 79 83	33 49 58 76 93-94		62 84	63 84	63 84	63 84	63 84	63 85	Thread Depth and Hole Type	
													UNC	
													UNF	
													UNEF	
													UN-8	
													MF	
													NPSM/NPSC	
													M	
													NPSF	
													Rp (BSPP)	
													G	
													NPT	
													Rc (BSPT)	
													STI	
													SELF-LOCK	
													P	
49 - 148	49 - 148	16 - 82	16 - 82	49 - 148	7 - 26									1.1
33 - 131	33 - 131	16 - 66	16 - 66	33 - 131	7 - 20									2.1
16 - 82	16 - 82	7 - 49	7 - 49	16 - 82	3 - 26									3.1
16 - 66	16 - 66			16 - 66	3 - 16									4.1
														5.1
16 - 66	16 - 66	7 - 33	7 - 33	16 - 66	3 - 26									1.1
16 - 66	16 - 66	7 - 33	7 - 33	16 - 66	3 - 26									2.1
16 - 49	16 - 49			16 - 49										3.1
														4.1
						7 - 33	33 - 82	49 - 148	49 - 148	49 - 148	49 - 148	49 - 148	49 - 148	1.1
						7 - 33	33 - 66	33 - 131	33 - 131	33 - 131	33 - 131	33 - 131	33 - 131	1.2
33 - 98	33 - 98	16 - 66	16 - 66	33 - 98				33 - 98	33 - 98	33 - 98	33 - 98	33 - 98	33 - 98	2.1
						7 - 26		33 - 82	33 - 82	33 - 82	33 - 82	33 - 82	33 - 82	2.2
						7 - 26		33 - 82	33 - 82	33 - 82	33 - 82	33 - 82	33 - 82	3.1
						7 - 26		33 - 66	33 - 66	33 - 66	33 - 66	33 - 66	33 - 66	3.2
						7 - 33		49 - 148	49 - 148	49 - 148	49 - 148	49 - 148	49 - 148	4.1
						7 - 33		33 - 131	33 - 131	33 - 131	33 - 131	33 - 131	33 - 131	4.2
														1.1
														1.2
														1.3
														1.4
														1.5
														1.6
66 - 197	66 - 197													2.1
														2.2
														2.3
														2.4
16 - 82	16 - 82													2.5
16 - 82	16 - 82													2.6
														2.7
														2.8
														3.1
														3.2
														4.1
														4.2
														4.3
														4.4
														5.1
														5.2
														5.3
														1.1
														1.2
														1.3
														2.1
														2.2
														2.3
														2.4
														2.5
														2.6
														1.1
														1.2
														1.3
														1.4
														1.5



Product Finder

V_c

UNC

UNF

UNEF

UN-8

MF

NPSM/NPSC

M

NPSF

Rp (BSPP)

G

NPT

Rc (BSPT)

STI

SELF-LOCK

Accessories

Tech. Info



1) Threading in through holes is possible only with external cooling/lubrication



- Product Finder
- V_c
- UNC
- UNF
- UNEF
- UN-8
- M
- MF
- NPSM/NPSC
- NPSF
- Rp (BSPP)
- G
- NPT
- NPTF
- Rc (BSPT)
- STI
- SELF-LOCK
- Accessories
- Tech. Info

EMUGE
AL

EMUGE
GAL

EMUGE
PVC

AERO

EMUGE
TI



	Rekord B-AL GLT-8	Enorm AL GLT-8	Enorm AL/E GLT-8	Rekord A-GAL/E IKZ-TiCN	Rekord A-GAL/E IKZN-TiCN	Rekord D-GAL/E IKZ-TiCN	VHM-Rekord D-GAL/E IKZ-TiCN	Rekord D-PVC/E CRN	Rekord B-AERO NT	Rekord C-Ti NT2	Rekord C-Ti TiCN	Rekord D-Ti NT2	Rekord D-Ti TiCN
--	-------------------	----------------	------------------	-------------------------	--------------------------	-------------------------	-----------------------------	--------------------	------------------	-----------------	------------------	-----------------	------------------

	B / approx. 3	C / 2-3	E / 1.5-2	E / 1.5-2	E / 1.5-2	E / 1.5-2	E / 1.5-2	E / 1.5-2	B / approx. 3	D / 4-5	D / 4-5	C / 2-3	C / 2-3
--	---------------	---------	-----------	-----------	-----------	-----------	-----------	-----------	---------------	---------	---------	---------	---------

Thread Depth and Hole Type	max. 3 x d ₁			max. 2 x d ₁				max. 2 x d ₁	max. 3 x d ₁	max. 3 x d ₁		max. 2 x d ₁	

UNC	24	24							25	25, 35	25	25, 35	25
UNF	40	40							41	41, 51	41	41, 51	41
UNEF, UN-8												56	
M	63	63	64	64	64	64	65	65		65	65	65	65
MF													
NPSM/NPSC													
NPSF													
Rp (BSPP)													
G													
NPT													
NPTF													
Rc (BSPT)													
STI	119, 121, 124	124	119, 121									120, 122	
SELF-LOCK											126		126

P	1.1												
	2.1												
	3.1												
	4.1									7 - 33	16 - 66	7 - 33	16 - 66
	5.1									3 - 16	7 - 33	3 - 16	7 - 33

M	1.1												
	2.1												
	3.1												
	4.1								7 - 33	3 - 26	16 - 49	3 - 26	16 - 49

K	1.1												
	1.2												
	2.1												
	2.2												
	3.1												
	3.2												
	4.1												
	4.2												

N	1.1	49 - 131	49 - 131	49 - 131									
	1.2	49 - 131	49 - 131	49 - 131									
	1.3	49 - 131	49 - 131	49 - 131									
	1.4	49 - 131	49 - 131	49 - 131	49 - 131	49 - 131	49 - 131	131 - 262					
	1.5				49 - 131	49 - 131	49 - 131	131 - 262					
	1.6				33 - 98	33 - 98	33 - 98	98 - 197					

N	2.1												
	2.2												
	2.3												
	2.4									7 - 33	16 - 82	7 - 33	16 - 82
	2.5									7 - 33	16 - 82	7 - 33	16 - 82
	2.6												
	2.7									3 - 16	7 - 33	3 - 16	7 - 33
	2.8								3 - 16				

N	3.1												
	3.2												
	4.1												
	4.2								33 - 131				

S	1.1												
	1.2									7 - 33	16 - 49	7 - 33	16 - 49
	1.3									3 - 26	7 - 33	3 - 26	7 - 33

S	2.1									3 - 16	7 - 33	3 - 16	7 - 33
	2.2									3 - 26	7 - 33	3 - 26	7 - 33
	2.3									3 - 26	7 - 33	3 - 26	7 - 33
	2.4									3 - 26	7 - 33	3 - 26	7 - 33
	2.5									3 - 26	7 - 33	3 - 26	7 - 33
	2.6									3 - 26	7 - 33	3 - 26	7 - 33

H	1.1												
	1.2												
	1.3												
	1.4												
	1.5												



Thread Depth and Hole Type

- UNC
- UNF
- UNEF
- UN-8
- MF
- NPSM/NPSC
- M
- MF
- NPSM/NPSC
- NPSF
- Rp (BSPP)
- G
- NPT
- NPTF
- Rc (BSPT)
- STI
- SELF-LOCK

Product Finder

V_c

UNC

UNF

UNEF

UN-8

MF

NPSM/NPSC

M

MF

NPSM/NPSC

NPSF

Rp (BSPP)

G

NPT

NPTF

Rc (BSPT)

STI

SELF-LOCK

Accessories

Tech. Info



Rekord DF-TILEG TiCN	Rekord C-NI-PM TiCN	Rekord DF-NI-PM TiCN	Rekord A-H NT	Rekord A-H TiCN	Rekord A-H-IKZ TiCN	Rekord A-H-IKZN TiCN	Rekord A-H/E NT	Rekord A-H/E TiN	VHM/KHM Rekord A-H-IKZ	VHM/KHM Rekord A-H/E-IKZ	Thread Depth and Hole Type
C / 2-3	D / 4-5	C / 2-3	C / 2-3	C / 2-3	C / 2-3	C / 2-3	E / 1.5-2	E / 1.5-2	C / 2-3	E / 1.5-2	
max. 2 x d ₁	max. 3 x d ₁	max. 2 x d ₁	max. 2 x d ₁		max. 2 x d ₁		max. 2 x d ₁		max. 2 x d ₁		
66	26 42 66	26 42 66	26, 36 42, 52 56 67, 79 85	26, 36 42, 52 67 85	27 43 67 85	67 85	81 97	81 97	67 85		
		122	103	103						104	
			16 - 82	49 - 148	49 - 148	49 - 148	16 - 82	49 - 148			1.1
			16 - 66	33 - 131	33 - 131	33 - 131	16 - 66	33 - 131			2.1
			7 - 49	16 - 82	16 - 82	16 - 82	7 - 49	16 - 82			3.1
				16 - 66	16 - 66	16 - 66		16 - 66			4.1
									16 - 49	16 - 49	5.1
											1.1
											2.1
7 - 33	7 - 33	7 - 33									3.1
											4.1
			33 - 82	49 - 148	49 - 148	49 - 148	33 - 82	49 - 148	131 - 262	131 - 262	1.1
			33 - 66	33 - 131	33 - 131	33 - 131	33 - 66	33 - 131	98 - 197	98 - 197	1.2
			16 - 66	33 - 98	33 - 98	33 - 98	16 - 66	33 - 98	98 - 197	98 - 197	2.1
			16 - 49	33 - 82	33 - 82	33 - 82	16 - 49	33 - 82	66 - 131	66 - 131	2.2
			16 - 49	33 - 82	33 - 82	33 - 82	16 - 49	33 - 82	66 - 131	66 - 131	3.1
			16 - 33	33 - 66	33 - 66	33 - 66	16 - 33	33 - 66	66 - 131	66 - 131	3.2
			33 - 82	49 - 148	49 - 148	49 - 148	33 - 82	49 - 148	131 - 262	131 - 262	4.1
			33 - 66	33 - 131	33 - 131	33 - 131	33 - 66	33 - 131	98 - 197	98 - 197	4.2
											1.1
											1.2
											1.3
											1.4
									66 - 197	66 - 197	1.5
									66 - 131	66 - 131	1.6
											2.1
											2.2
											2.3
			7 - 33	16 - 82	16 - 82	16 - 82	7 - 33	16 - 82			2.4
			7 - 33	16 - 82	16 - 82	16 - 82	7 - 33	16 - 82			2.5
			16 - 66	33 - 98	33 - 98	33 - 98	16 - 66	33 - 98	66 - 131	66 - 131	2.6
			3 - 16	7 - 33	7 - 33	7 - 33	3 - 16	7 - 33	16 - 49	16 - 49	2.7
	3 - 16	3 - 16							3 - 26	3 - 26	2.8
											3.1
											3.2
			16 - 82	33 - 131	33 - 131	33 - 131	16 - 82	33 - 131	66 - 197	66 - 197	4.1
									33 - 82	33 - 82	4.2
									16 - 49	16 - 49	4.3
									16 - 49	16 - 49	4.4
			33 - 66	33 - 66	33 - 66	33 - 66	33 - 66	33 - 66	66 - 197	66 - 197	5.1
									33 - 98	33 - 98	5.2
											5.3
											1.1
7 - 33	7 - 33	7 - 33									1.2
3 - 26	3 - 26	3 - 26									1.3
											2.1
											2.2
											2.3
											2.4
											2.5
											2.6
											3.1
											3.2
											4.1
											4.2
											4.3
											4.4
											5.1
											5.2
											5.3
											1.1
7 - 33	7 - 33	7 - 33									1.2
3 - 26	3 - 26	3 - 26									1.3
											2.1
											2.2
											2.3
											2.4
											2.5
											2.6
											3.1
											3.2
											4.1
											4.2
											4.3
											4.4
											5.1
											5.2
											5.3
											1.1
											1.2
											1.3
											1.4
											1.5

Product Finder

V_c

UNC

UNF

UNEF

UN-8

M

MF

NPSM/NPSC

NPSF

Rp (BSPP)

G

NPT

NPTF

Rc (BSPT)

STI

SELF-LOCK

Accessories

Tech. Info



Thread Depth and Hole Type

UNC
UNF
UNEF, UN-8
M
MF
NPSM/NPSC
NPSF
Rp (BSPP)
G
NPT
NPTF
Rc (BSPT)
STI
SELF-LOCK



Rekord A-HCUT-PM TiCN	VHM-Rekord A-HCUT/D TiCN	VHM-Rekord A-HCUT/C TiCN 3)	Rekord A-Z TiCN	Rekord A-Z-1KZ TiCN	Rekord A-Z-1KZN TiCN	Rekord A-Z/E TiCN	Rekord A-Z/E-1KZ TiCN	Rekord A-Z-1KZ-LF4 TiCN	Rekord B-Z-PM TiN-70	Rekord B-Z-PM GLT-1	Rekord B-Z-1KZN PM-TiN-70	Rekord B-Z-1KZN PM-GLT-1	Rekord D-Z TiN
-----------------------	--------------------------	-----------------------------	-----------------	---------------------	----------------------	-------------------	-----------------------	-------------------------	----------------------	---------------------	---------------------------	--------------------------	----------------

C / 2-3	D / 4-5	C / 2-3	C / 2-3	C / 2-3	C / 2-3	E / 1.5-2	E / 1.5-2	C / 2-3	B / 4-5	B / 4-5	B / 4-5	B / 4-5	C / 2-3
---------	---------	---------	---------	---------	---------	-----------	-----------	---------	---------	---------	---------	---------	---------

max. 1.5 x d ₁	max. 1.5 x d ₁	max. 2 x d ₁	max. 2 x d ₁	max. 2 x d ₁	max. 2 x d ₁	max. 2 x d ₁	max. 2 x d ₁	max. 4 x d ₁	max. 3 x d ₁				max. 2 x d ₁
---------------------------	---------------------------	-------------------------	-------------------------	-------------------------	-------------------------	-------------------------	-------------------------	-------------------------	-------------------------	--	--	--	-------------------------

27			27	27	27	27	27	27	28	28	28		28
----	--	--	----	----	----	----	----	----	----	----	----	--	----

43			43	43	43	43	43	43	44	44	44		44
----	--	--	----	----	----	----	----	----	----	----	----	--	----

68	69	69	70	70	70	70	70	77	71	71	71	71	72
----	----	----	----	----	----	----	----	----	----	----	----	----	----

86	87	87	88	88	88	88	88	95	89	89	89	89	89
----	----	----	----	----	----	----	----	----	----	----	----	----	----

101, 104	101	101											
----------	-----	-----	--	--	--	--	--	--	--	--	--	--	--

										127, 128			
--	--	--	--	--	--	--	--	--	--	----------	--	--	--

P	1.1			49 - 148	49 - 148	49 - 148	49 - 148	49 - 148	49 - 148	49 - 148	49 - 148	49 - 148	49 - 148	
	2.1			33 - 131	33 - 131	33 - 131	33 - 131	33 - 131	33 - 131	33 - 131	33 - 131	33 - 131	33 - 131	33 - 131
	3.1			16 - 82	16 - 82	16 - 82	16 - 82	16 - 82	16 - 82	16 - 82	16 - 82	16 - 82	16 - 82	16 - 82
	4.1			16 - 66	16 - 66	16 - 66	16 - 66	16 - 66	16 - 66	16 - 66	16 - 66	16 - 66	16 - 66	16 - 66
	5.1									7 - 49	7 - 49	7 - 49	7 - 49	7 - 33

M	1.1									16 - 66	16 - 66	16 - 66	16 - 66
	2.1									16 - 66	16 - 66	16 - 66	16 - 66
	3.1									16 - 49	16 - 49	16 - 49	16 - 49
	4.1												

K	1.1			49 - 148	49 - 148	49 - 148	49 - 148	49 - 148	49 - 148				
	1.2			33 - 131	33 - 131	33 - 131	33 - 131	33 - 131	33 - 131				
	2.1			33 - 98	33 - 98	33 - 98	33 - 98	33 - 98	33 - 98	33 - 98	33 - 98	33 - 98	33 - 98
	2.2			33 - 82	33 - 82	33 - 82	33 - 82	33 - 82	33 - 82	33 - 82	33 - 82	33 - 82	33 - 82
	3.1			33 - 82	33 - 82	33 - 82	33 - 82	33 - 82	33 - 82				
	3.2			33 - 66	33 - 66	33 - 66	33 - 66	33 - 66	33 - 66				
	4.1			49 - 148	49 - 148	49 - 148	49 - 148	49 - 148	49 - 148	49 - 148	49 - 148	49 - 148	49 - 148
	4.2			33 - 131	33 - 131	33 - 131	33 - 131	33 - 131	33 - 131	33 - 131	33 - 131	33 - 131	33 - 131

N	1.1													
	1.2													
	1.3													
	1.4				49 - 131	49 - 131	49 - 131	49 - 131	49 - 131	49 - 131	49 - 131	49 - 131	49 - 131	49 - 131
	1.5				49 - 131	49 - 131	49 - 131	49 - 131	49 - 131	49 - 131	49 - 131	49 - 131	49 - 131	
	1.6				33 - 98	33 - 98	33 - 98	33 - 98	33 - 98	33 - 98	33 - 98	33 - 98	33 - 98	

N	2.1									16 - 98	16 - 98	16 - 98	16 - 98
	2.2									66 - 197	66 - 197	66 - 197	66 - 197
	2.3												
	2.4				16 - 82	16 - 82	16 - 82	16 - 82	16 - 82	16 - 82	16 - 82	16 - 82	16 - 82
	2.5				16 - 82	16 - 82	16 - 82	16 - 82	16 - 82	16 - 82	16 - 82	16 - 82	16 - 82
	2.6				33 - 98	33 - 98	33 - 98	33 - 98	33 - 98	33 - 98	33 - 98	33 - 98	33 - 98
	2.7				7 - 33	7 - 33	7 - 33	7 - 33	7 - 33	7 - 33	7 - 33	7 - 33	7 - 33
	2.8												

N	3.1												
	3.2												
	4.1				33 - 131	33 - 131	33 - 131	33 - 131	33 - 131	33 - 131	33 - 131	33 - 131	33 - 131
	4.2												
	4.3												
	4.4												
	5.1												
	5.2												

S	1.1									16 - 49	16 - 49	16 - 49	16 - 49
	1.2												
	1.3												
	2.1												
	2.2												
	2.3												
	2.4												
	2.5												

H	1.1	3 - 16											
	1.2	3 - 10											
	1.3		3 - 10	3 - 10									
	1.4		3 - 7	3 - 7									
	1.5												



Rekord D-Z- IKZ TIN	Rekord D-Z/ E-IKZ TIN	Rekord D-Z- BF TIN	Rekord D-Z- BF IKZ-TIN	Rekord D-Z/ E-BF IKZ-TIN	Rekord D-Z- IKZ LF4-TIN	Rekord D-Z- BF- IKZ LF4-TIN	Enorm Z	Enorm Z TIN	Enorm Z GLT-1	Enorm Z- IKZ GLT-1	Enorm Z/ E	Enorm Z/ E TIN	Enorm Z/ E TiCN	Enorm Z/ E GLT-1
C / 2-3	E / 1.5-2	C / 2-3	C / 2-3	E / 1.5-2	C / 2-3	C / 2-3	C / 2-3	C / 2-3	C / 2-3	C / 2-3	E / 1.5-2	E / 1.5-2	E / 1.5-2	E / 1.5-2

max. 2 x d₁



max. 4 x d₁



max. 3 x d₁

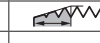

Thread Depth and Hole Type

29		29	29					29	29	29	29, 37	29, 37	30	30	UNC
45		45	45					45	45	45	45, 53	45, 53	46	46	UNF
72		57	72	72	77	77	72	73	73	73	73	73, 81	73	73	UNEF, UN-8
89	89	89	89	90	95	95					90	90, 91	90	90	M
											98	98			MF
											99	99			NPSM/NPSC
											100	100			NPSF
											105	105			Rp (BSPP)
															G
															NPT
															NPTF
							125				120, 123, 125	120, 123		120, 123, 125	Rc (BSPT)
											127, 130			127, 128	STI
															SELF-LOCK
							16 - 82	49 - 148	49 - 148	49 - 148	16 - 82	49 - 148	49 - 148	49 - 148	1.1
33 - 131	33 - 131	33 - 131	33 - 131	33 - 131	33 - 131	33 - 131	16 - 66	33 - 131	33 - 131	33 - 131	16 - 66	33 - 131	33 - 131	33 - 131	2.1
16 - 82	16 - 82	16 - 82	16 - 82	16 - 82	16 - 82	16 - 82	7 - 49	16 - 82	16 - 82	16 - 82	7 - 49	16 - 82	16 - 82	16 - 82	3.1
16 - 66	16 - 66	16 - 66	16 - 66	16 - 66	16 - 66	16 - 66	7 - 33	16 - 66	16 - 66	16 - 66	7 - 33	16 - 66	16 - 66	16 - 66	4.1
7 - 33	7 - 33	7 - 33	7 - 33	7 - 33	7 - 33	7 - 33									5.1
							7 - 33	16 - 66	16 - 66	16 - 66	7 - 33	16 - 66	16 - 66	16 - 66	1.1
							7 - 33	16 - 66	16 - 66	16 - 66	7 - 33	16 - 66	16 - 66	16 - 66	2.1
								16 - 49	16 - 49	16 - 49		16 - 49	16 - 49	16 - 49	3.1
														16 - 49	4.1
															1.1
															1.2
33 - 98	33 - 98	33 - 98	33 - 98	33 - 98	33 - 98	33 - 98									2.1
33 - 82	33 - 82	33 - 82	33 - 82	33 - 82	33 - 82	33 - 82									2.2
															3.1
															3.2
															4.1
															4.2
															1.1
															1.2
49 - 131	49 - 131	49 - 131	49 - 131	49 - 131	49 - 131	49 - 131		49 - 131	49 - 131	49 - 131		49 - 131	49 - 131	49 - 131	1.4
49 - 131	49 - 131	49 - 131	49 - 131	49 - 131	49 - 131	49 - 131		49 - 131	49 - 131	49 - 131		49 - 131	49 - 131	49 - 131	1.5
33 - 98	33 - 98	33 - 98	33 - 98	33 - 98	33 - 98	33 - 98		33 - 98	33 - 98	33 - 98		33 - 98	33 - 98	33 - 98	1.6
							16 - 66	16 - 98	16 - 98	16 - 98	16 - 66	16 - 98	16 - 98	16 - 98	2.1
								66 - 197	66 - 197	66 - 197		66 - 197	66 - 197	66 - 197	2.2
															2.3
16 - 82	16 - 82	16 - 82	16 - 82	16 - 82	16 - 82	16 - 82		16 - 82	16 - 82	16 - 82		16 - 82	16 - 82	16 - 82	2.4
16 - 82	16 - 82	16 - 82	16 - 82	16 - 82	16 - 82	16 - 82		16 - 82	16 - 82	16 - 82		16 - 82	16 - 82	16 - 82	2.5
															2.6
															2.7
															2.8
															3.1
															3.2
															4.1
															4.2
															4.3
															4.4
															5.1
															5.2
															5.3
							16 - 49	16 - 49	16 - 49		16 - 49	16 - 49	16 - 49		1.1
															1.2
															1.3
															2.1
															2.2
															2.3
															2.4
															2.5
															2.6
															1.1
															1.2
															1.3
															1.4
															1.5

Product Finder

V_c

UNC

UNF

UNEF

UN-8

MF

NPSM/NPSC

NPSF

Rp (BSPP)

G

NPT

NPTF

Rc (BSPT)

STI

SELF-LOCK

Accessories

Tech. Info



- Product Finder
- V_c
- UNC
- UNF
- UNEF
- UN-8
- M
- MF
- NPSM/NPSC
- NPSF
- Rp (BSPP)
- G
- NPT
- NPTF
- Rc (BSPT)
- STI
- SELF-LOCK
- Accessories
- Tech. Info

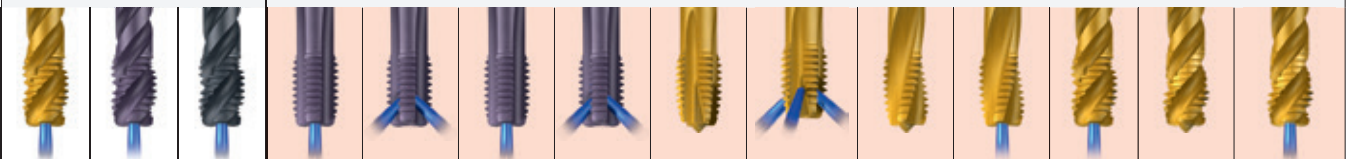

	Enorm Z/E-IKZ TIN	Enorm Z/E-IKZ TiCN	Enorm Z/E-IKZ GLT-1	Rekord A-SPEED IKZ-TiCN	Rekord A-SPEED IKZN-TiCN	Rekord A-SPEED/E IKZ-TiCN	Rekord A-SPEED/E IKZN-TiCN	Rekord B-Z-SPEED PM-TiN-70	Rekord B-Z-SPEED-IKZN PM-TiN-70	Rekord D-SPEED TiN	Rekord D-SPEED-IKZ TiN	Enorm SPEED IKZ-TiN	Enorm Z-SPEED-X PM-TiN-60	Enorm Z-SPEED-X-IKZ PM-TiN-60
Thread Depth and Hole Type	max. 3 x d ₁			max. 2 x d ₁		max. 2 x d ₁		max. 3 x d ₁			max. 2 x d ₁		max. 3 x d ₁	
UNC		30	30, 31	31	31	31		31	31	31	32	32		
UNF		46	46, 47	47	47	47		47	47	47	48	48		
UNEF, UN-8														
M	73			74	74	74	74	75	75				75	75
MF	90			91	91	91	91	91	91				92	92
NPSM/NPSC														
NPSF														
Rp (BSPP)														
G														
NPT														
NPTF														
Rc (BSPT)														
STI														
SELF-LOCK														
P														
1.1	49 - 148	49 - 148	49 - 148					131 - 262	131 - 262	131 - 262	131 - 262	131 - 262		
2.1	33 - 131	33 - 131	33 - 131					98 - 197	98 - 197	98 - 197	98 - 197	98 - 197	98 - 197	98 - 197
3.1	16 - 82	16 - 82	16 - 82					66 - 131	66 - 131	66 - 131	66 - 131	66 - 131	66 - 131	66 - 131
4.1	16 - 66	16 - 66	16 - 66					33 - 98	33 - 98	33 - 98	33 - 98	33 - 98	33 - 98	33 - 98
5.1														
M														
1.1	16 - 66	16 - 66	16 - 66							33 - 82	33 - 82	33 - 82		
2.1	16 - 66	16 - 66	16 - 66							33 - 82	33 - 82	33 - 82	33 - 82	
3.1	16 - 49	16 - 49	16 - 49							16 - 66	16 - 66	16 - 66		
4.1														
K														
1.1				131 - 262	131 - 262	131 - 262	131 - 262							
1.2				98 - 197	98 - 197	98 - 197	98 - 197							
2.1				98 - 197	98 - 197	98 - 197	98 - 197	98 - 197	98 - 197	98 - 197	98 - 197	98 - 197	98 - 197	98 - 197
2.2				66 - 131	66 - 131	66 - 131	66 - 131	66 - 131	66 - 131	66 - 131	66 - 131	66 - 131	66 - 131	66 - 131
3.1				66 - 131	66 - 131	66 - 131	66 - 131	66 - 131	66 - 131	66 - 131	66 - 131	66 - 131	66 - 131	66 - 131
3.2				66 - 131	66 - 131	66 - 131	66 - 131	66 - 131	66 - 131	66 - 131	66 - 131	66 - 131	66 - 131	66 - 131
4.1				131 - 262	131 - 262	131 - 262	131 - 262							
4.2				98 - 197	98 - 197	98 - 197	98 - 197							
N														
1.1												66 - 197		
1.2												66 - 197		
1.3												66 - 197		
1.4	49 - 131	49 - 131	49 - 131	66 - 197	66 - 197	66 - 197	66 - 197	66 - 197	66 - 197	66 - 197	66 - 197	66 - 197	66 - 197	66 - 197
1.5	49 - 131	49 - 131	49 - 131	66 - 197	66 - 197	66 - 197	66 - 197	66 - 197	66 - 197	66 - 197	66 - 197	66 - 197	66 - 197	66 - 197
1.6	33 - 98	33 - 98	33 - 98	66 - 131	66 - 131	66 - 131	66 - 131	66 - 131	66 - 131	66 - 131	66 - 131	66 - 131	66 - 131	66 - 131
2.1	16 - 98	16 - 98	16 - 98							66 - 131	66 - 131	66 - 131	66 - 131	66 - 131
2.2	66 - 197	66 - 197	66 - 197									66 - 131	66 - 131	66 - 131
2.3												131 - 262	131 - 262	131 - 262
2.4	16 - 82	16 - 82	16 - 82											
2.5	16 - 82	16 - 82	16 - 82											
2.6														
2.7														
2.8														
3.1														
3.2														
4.1														
4.2														
4.3														
4.4														
5.1														
5.2														
5.3														
S														
1.1	16 - 49	16 - 49	16 - 49											
1.2														
1.3														
2.1														
2.2														
2.3														
2.4														
2.5														
2.6														
H														
1.1														
1.2														
1.3														
1.4														
1.5														

1) Threading in through holes is possible only with external cooling/lubrication

Tapered Taps	EMUGE -STEEL-		EMUGE -VA-								EMUGE -NI-	Thread Depth and Hole Type
	Rekord A-STEEL	Rekord A-STEEL TIN	Rekord A-VA	Rekord A-VA-AZ	Rekord A-VA-AZ TIN	Rekord D-VA	Rekord D-VA TIN	Rekord D-VA-1KZN TiCN	Rekord D-VA-AZ	Rekord D-VA-AZ TIN	Rekord D-R10-Ni TiCN	
	C / 2-3	C / 2-3	C / 2-3	C / 2-3	C / 2-3	C / 2-3	C / 2-3	C / 2-3	C / 2-3	C / 2-3	C / 2-3	C / 2-3
	—	—	—	—	—	—	—	—	—	—	—	—
	107, 109 112, 113 117	107, 109 112, 113	116	109 112, 113	109 112, 113	107, 110 114	107, 110 114	110 114	108, 110 114	108, 110 114	111 115	
	7 - 26	7 - 26	7 - 26	7 - 26	7 - 26	7 - 26	7 - 26	7 - 26	7 - 26	7 - 26	7 - 26	1.1
	7 - 20	7 - 20	7 - 20	7 - 20	7 - 20	7 - 20	7 - 20	7 - 20	7 - 20	7 - 20	7 - 20	2.1
			3 - 26	3 - 26	3 - 26	3 - 26	3 - 26	3 - 26	3 - 26	3 - 26	3 - 26	3.1
			3 - 16	3 - 16	3 - 16							4.1
												5.1
			3 - 26	3 - 26	3 - 26	3 - 26	3 - 26	3 - 26	3 - 26	3 - 26	3 - 26	1.1
			3 - 26	3 - 26	3 - 26	3 - 26	3 - 26	3 - 26	3 - 26	3 - 26	3 - 26	2.1
				3 - 16	3 - 16	3 - 16	3 - 16	3 - 16	3 - 16	3 - 16	3 - 16	3.1
												4.1
	7 - 33	7 - 33										1.1
	7 - 33	7 - 33										1.2
			7 - 26	7 - 26	7 - 26							2.1
			7 - 26	7 - 26	7 - 26							2.2
			7 - 26	7 - 26	7 - 26							3.1
			7 - 26	7 - 26	7 - 26							3.2
			7 - 33	7 - 33	7 - 33							4.1
			7 - 33	7 - 33	7 - 33							4.2
												1.1
												1.2
												1.3
			7 - 33									1.4
			7 - 33									1.5
												1.6
	7 - 33	7 - 33										2.1
	7 - 33	7 - 33										2.2
			3 - 26	3 - 26	3 - 26							2.3
			3 - 26	3 - 26	3 - 26							2.4
			3 - 26	3 - 26	3 - 26							2.5
												2.6
												2.7
												2.8
												3.1
												3.2
												4.1
												4.2
												4.3
												4.4
												5.1
												5.2
												5.3
												1.1
												1.2
												1.3
												2.1
												2.2
												2.3
												2.4
												2.5
												2.6
												1.1
												1.2
												1.3
												1.4
												1.5

Product Finder

V_c

UNC

UNF

UNEF

UN-8

MF

NPSM/NPSC

NPSF

Rp (BSPP)

G

NPT

NPTF

Rc (BSPT)

STI

SELF-LOCK

Accessories

Tech. Info



- Product Finder
- V_c
- UNC
- UNF
- UNEF
- UN-8
- M
- MF
- NPSM/NPSC
- NPSF
- Rp (BSPP)
- G
- NPT
- NPTF
- Rc (BSPT)
- STI
- SELF-LOCK
- Accessories
- Tech. Info

DIN Length - ANSI Shank

Overall length acc. to DIN 371, DIN 376

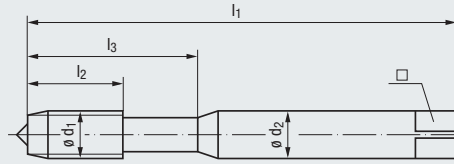

Reinforced Shank
(No.1 - 3/8)

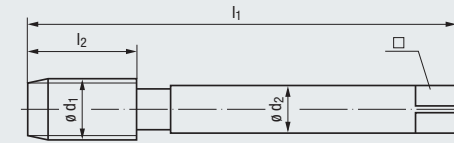

Reduced Shank
(7/16 - 2)



UNC
Unified Coarse Thread
ASME B1.1

Class of Fit
Coating
Cutting Material
Technical Characteristics



Thread Depth and Hole Shape

Applications - Material

STEEL
Steel
Materials



2B	2B	2B	2B	3B
TIN	TIN	TICN		
HSS Extra	HSS Extra	HSS Extra	HSS Extra	HSS Extra
R15	R15	R15	R35	R35
B / 4-5	C / 2-3	C / 2-3	C / 2-3	C / 2-3
E / 0	E / 0	E / 0	E / 0	E / 0

max. 3 x d ₁	max. 2 x d ₁		max. 2.5 x d ₁	

P 1.1-4.1 K 2.1 N 2.2, 2.4-5	P 1.1-4.1 K 1.1-4.2 N 1.4-5, 2.4-5	P 1.1-4.1 K 1.1-4.2 N 1.4-5, 2.4-5	P 1.1-3.1 N 2.2	P 1.1-3.1 N 2.2
------------------------------------	--	--	--------------------	--------------------

Reinforced Shank

Nominal Size ø d ₁	T.P.I.	l ₁	l ₂	inch l ₃	ø d ₂	□	Tool Identification		BU208400		BU451400		BU979000		BU501000		BU501010	
							Rekord 1B-STEEL-L TIN	Flutes	Rekord 1D-STEEL TIN	Flutes	Rekord 1D-STEEL IKZ-TICN	Flutes	Enorm 1-STEEL	Flutes	Enorm 1-STEEL	Flutes		
No. 1	64	1.772	0.276	0.472	0.141	0.110	0.0595	.5000	●	2	●	2			●	2	●	2
No. 2	56	1.772	0.276	0.472	0.141	0.110	0.0700	.5001	●	2	●	2			●	2	●	2
No. 3	48	1.969	0.354	0.551	0.141	0.110	0.0820	.5002	●	2	●	2			●	2	●	2
No. 4	40	2.205	0.433	0.709	0.141	0.110	0.0890	.5003	●	2	●	2			●	2	●	2
No. 5	40	2.205	0.433	0.709	0.141	0.110	0.1015	.5004	●	3	●	2			●	3	●	3
No. 6	32	2.205	0.472	0.787	0.141	0.110	0.1110	.5005	●	3	●	2			●	3	●	3
No. 8	32	2.480	0.512	0.827	0.168	0.131	0.1360	.5006	●	3	●	3			●	3	●	3
No. 10	24	2.756	0.591	0.984	0.194	0.152	0.1520	.5007	●	3	●	3	●	3	●	3	●	3
No. 12	24	3.150	0.630	1.142	0.220	0.165	0.1770	.5008	●	3	●	3			●	3	●	3
1/4	20	3.150	0.669	1.181	0.255	0.191	0.2040	.5009	●	3	●	3	●	3	●	3	●	3
5/16	18	3.543	0.787	1.378	0.318	0.238	0.2610	.5010	●	3	●	3	●	3	●	3	●	3
3/8	16	3.937	0.866	1.535	0.381	0.286	0.3160	.5011	●	3	●	3	●	3	●	3	●	3

Reduced Shank

Nominal Size ø d ₁	T.P.I.	l ₁	l ₂	inch l ₃	ø d ₂	□	Tool Identification		CU208400		CU451400		CU979000		CU501000		CU501010	
							Rekord 2B-STEEL-L TIN	Flutes	Rekord 2D-STEEL TIN	Flutes	Rekord 2D-STEEL IKZ-TICN	Flutes	Enorm 2-STEEL	Flutes	Enorm 2-STEEL	Flutes		
7/16	14	3.937	0.866	—	0.323	0.242	0.3680	.5012	●	3	●	3	●	3	●	3	●	3
1/2	13	4.331	0.984	—	0.367	0.275	0.4219	.5013	●	3	●	3	●	3	●	3	●	3
9/16	12	4.331	1.024	—	0.429	0.322	0.4844	.5014	●	3	●	3	●	3	●	3	●	3
5/8	11	4.331	1.063	—	0.480	0.360	0.5313	.5015	●	3	●	3	●	3	●	3	●	3
3/4	10	4.921	1.181	—	0.590	0.442	0.6563	.5016	●	3	●	3	●	3	●	3	●	3
7/8	9	5.512	1.260	—	0.697	0.523	0.7656	.5017	●	3	●	3	●	3	●	4	●	4
1	8	6.299	1.417	—	0.800	0.600	0.8750	.5018	●	3	●	3	●	3	●	4	●	4
1 1/8	7	7.087	1.575	—	0.896	0.672	0.9843	.5019	●	3	●	3			●	4	●	4
1 1/4	7	7.087	1.575	—	1.021	0.766	1.1094	.5020	●	4	●	4			●	4	●	4
1 3/8	6	7.874	1.969	—	1.108	0.831	1.2205	.5021	●	4					●	4	●	4
1 1/2	6	7.874	1.969	—	1.233	0.925	1.3386	.5022	●	4					●	4	●	4
1 3/4	5	8.661	2.283	—	1.430	1.072	1.5551	.5023	●	4					●	5	●	5
2	4 1/2	9.843	2.559	—	1.644	1.233	1.7812	.5024	●	4					●	5	●	5

VA
Stainless Steel
Materials

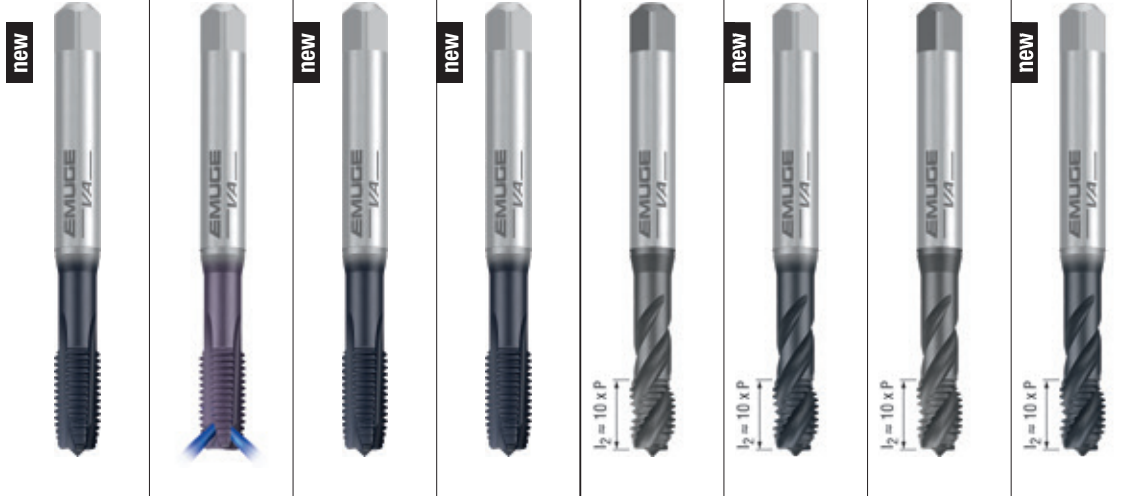

new	new	new	new	new	new	new	new
2B	2B	3B	Enlarge	2B	2B	3B	3B
GLT-1	TICN	GLT-1	GLT-1	NE2	GLT-1	NE2	GLT-1
HSS Extra	HSS Extra	HSS Extra	HSS Extra	HSS Extra	HSS Extra	HSS Extra	HSS Extra
B / 4-5	B / 4-5	B / 4-5	B / 4-5	R35	R35	R35	R35
E / O / P	E / O	E / O / P	E / O / P	C / 2-3	C / 2-3	C / 2-3	C / 2-3
				E / O / P	E / O / P	E / O / P	E / O / P

Class of Fit
Coating
Cutting Material
Technical Characteristics

max. 3 x d₁



max. 2.5 x d₁



Thread Depth
and Hole Shape

P 1.1-4.1	P 1.1-4.1	P 1.1-4.1	P 1.1-4.1	P 1.1-3.1	P 1.1-4.1	P 1.1-3.1	P 1.1-4.1
M 1.1-3.1	M 1.1-3.1	M 1.1-3.1	M 1.1-3.1	M 1.1-2.1	M 1.1-3.1	M 1.1-2.1	M 1.1-3.1
K 2.1	K 2.1	K 2.1	K 2.1	K 2.1	K 2.1	K 2.1	K 2.1
N 2.2	N 2.2, 2.5-6	N 2.2	N 2.2				

Applications – Material

BU20C300		BU089300		BU20C310		BU20C344		BU503200		BU50C300		BU503210		BU50C310		Tool Identification		
Rekord 1B-VA GLT-1	Flutes	Rekord 1B-VA-1KZN TICN	Flutes	Rekord 1B-VA GLT-1	Flutes	Rekord 1B-VA GLT-1	Flutes	Enorm 1-VA NE2	Flutes	Enorm 1-VA GLT-1	Flutes	Enorm 1-VA NE2	Flutes	Enorm 1-VA GLT-1	Flutes	Dimens. ID	Nominal Size ø d ₁	T.P.I.
●	2			●	2			●	2	●	2	●	2	●	2	.5000	No. 1	64
●	2			●	2			●	2	●	2	●	2	●	2	.5001	No. 2	56
●	2			●	2			●	2	●	2	●	2	●	2	.5002	No. 3	48
●	2			●	2			●	2	●	2	●	2	●	2	.5003	No. 4	40
●	3			●	3			●	3	●	3	●	3	●	3	.5004	No. 5	40
●	3			●	3			●	3	●	3	●	3	●	3	.5005	No. 6	32
●	3			●	3			●	3	●	3	●	3	●	3	.5006	No. 8	32
●	3	●	3	●	3			●	3	●	3	●	3	●	3	.5007	No. 10	24
●	3			●	3			●	3	●	3	●	3	●	3	.5008	No. 12	24
●	3	●	3	●	3	●	3	●	3	●	3	●	3	●	3	.5009	1/4	20
●	3	●	3	●	3	●	3	●	3	●	3	●	3	●	3	.5010	5/16	18
●	3	●	3	●	3	●	3	●	3	●	3	●	3	●	3	.5011	3/8	16

CU20C300		CU089300		CU20C310		CU20C344		CU503200		CU50C300		CU503210		CU50C310		Tool Identification		
Rekord 2B-VA GLT-1	Flutes	Rekord 2B-VA-1KZN TICN	Flutes	Rekord 2B-VA GLT-1	Flutes	Rekord 2B-VA GLT-1	Flutes	Enorm 2-VA NE2	Flutes	Enorm 2-VA GLT-1	Flutes	Enorm 2-VA NE2	Flutes	Enorm 2-VA GLT-1	Flutes	Dimens. ID	Nominal Size ø d ₁	T.P.I.
●	3	●	3	●	3	● (+.0050)	3	●	3	●	3	●	3	●	3	.5012	7/16	14
●	3	●	3	●	3	● (+.0050)	3	●	3	●	3	●	3	●	3	.5013	1/2	13
●	3			●	3			●	3	●	3	●	3	●	3	.5014	9/16	12
●	3	●	3	●	3	● (+.0050)	3	●	3	●	3	●	3	●	3	.5015	5/8	11
●	3	●	3	●	3	● (+.0050)	3	●	3	●	3	●	3	●	3	.5016	3/4	10
●	3			●	3			●	4	●	4	●	4	●	4	.5017	7/8	9
●	3	●	3	●	3			●	4	●	4	●	4	●	4	.5018	1	8
●	3			●	3			●	4	●	4	●	4	●	4	.5019	1 1/8	7
●	4			●	4			●	4	●	4	●	4	●	4	.5020	1 1/4	7
●	4			●	4			●	4	●	4	●	4	●	4	.5021	1 3/8	6
●	4			●	4			●	4	●	4	●	4	●	4	.5022	1 1/2	6
●	4			●	4			●	5	●	5					.5023	1 3/4	5
●	4			●	4			●	5	●	5					.5024	2	4 1/2

● = In stock
★ = Allow 7 days for delivery

1) Tool Identification = BU20C343

Product Finder

V_c

UNC

UNF

UNEF

UN-8

MF

NPSM/NPSC

NPSF

Rp (BSP)

G

NPT

NPTF

Rc (BSPT)

STI

SELF-LOCK

Accessories

Tech. Info



- Product Finder
- V_c
- UNC
- UNF
- UNEF
- UN-8
- M
- MF
- NPSM/NPSC
- NPSF
- Rp (BSPP)
- G
- NPT
- NPTF
- Rc (BSPT)
- STI
- SELF-LOCK
- Accessories
- Tech. Info

DIN Length - ANSI Shank

Overall length acc. to DIN 371, DIN 376

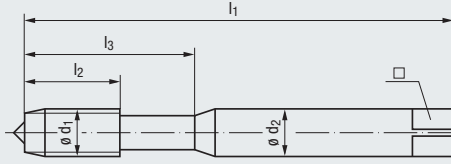

Reinforced Shank
(No. 1 - 3/8)

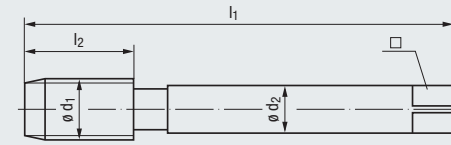

Reduced Shank
(7/16 - 2)

UNC



Unified Coarse Thread
ASME B1.1

Class of Fit: **Enlarge**
Coating: **GLT-1**
Cutting Material: **HSS Extra**
Technical Characteristics: **R35**
C / 2-3
E / O / P

Thread Depth and Hole Shape

Applications - Material

VA
Stainless Steel
Materials



new

Enlarge
GLT-1
HSS Extra
R35
C / 2-3
E / O / P

max. 2.5 x d₁



P 1.1-4.1
M 1.1-3.1
K 2.1

AL
Aluminum
Wrought Alloys



new



new



new

2B
GLT-8
HSS Extra
B / approx. 3
E / O

max. 3 x d₁



N 1.1-4

2B
GLT-8
HSS Extra
R45
C / 2-3
E / O

max. 2.5 x d₁



N 1.1-4

3B
GLT-8
HSS Extra
R45
C / 2-3
E / O

max. 2.5 x d₁



N 1.1-4

Reinforced Shank

								Tool Identification		BU50C344		BU20S800		BU50S800		BU50S810	
Nominal Size ø d ₁	T.P.I.	l ₁	l ₂	inch		ø d ₂	□	Image	Dimens. ID	Enorm 1-VA GLT-1	Flutes	Rekord 1B-AL GLT-8	Flutes	Enorm 1-AL GLT-8	Flutes	Enorm 1-AL GLT-8	Flutes
				No. 1	64					1.772	0.276	0.472	0.141	0.110	0.0595	.5000	
No. 2	56	1.772	0.276	0.472	0.141	0.110	0.0700	.5001			●	2	●	2	●	2	
No. 3	48	1.969	0.354	0.551	0.141	0.110	0.0820	.5002			●	2	●	2	●	2	
No. 4	40	2.205	0.433	0.709	0.141	0.110	0.0890	.5003			●	2	●	2	●	2	
No. 5	40	2.205	0.433	0.709	0.141	0.110	0.1015	.5004			●	2	●	2	●	2	
No. 6	32	2.205	0.472	0.787	0.141	0.110	0.1110	.5005			●	2	●	2	●	2	
No. 8	32	2.480	0.512	0.827	0.168	0.131	0.1360	.5006			●	2	●	2	●	2	
No. 10	24	2.756	0.591	0.984	0.194	0.152	0.1520	.5007	1) ● (+.0035)	3	●	2	●	2	●	2	
No. 12	24	3.150	0.630	1.142	0.220	0.165	0.1770	.5008			●	2	●	2	●	2	
1/4	20	3.150	0.669	1.181	0.255	0.191	0.2040	.5009	● (+.0050)	3	●	2	●	2	●	2	
5/16	18	3.543	0.787	1.378	0.318	0.238	0.2610	.5010	● (+.0050)	3	●	2	●	2	●	2	
3/8	16	3.937	0.866	1.535	0.381	0.286	0.3160	.5011	● (+.0050)	3	●	2	●	2	●	2	

Reduced Shank

								Tool Identification		CU50C344		CU20S800		CU50S800		CU50S810	
Nominal Size ø d ₁	T.P.I.	l ₁	l ₂	inch		ø d ₂	□	Image	Dimens. ID	Enorm 2-VA GLT-1	Flutes	Rekord 2B-AL GLT-8	Flutes	Enorm 2-AL GLT-8	Flutes	Enorm 2-AL GLT-8	Flutes
				7/16	14					3.937	0.866	—	0.323	0.242	0.3680	.5012	● (+.0050)
1/2	13	4.331	0.984	—	0.367	0.275	0.4219	.5013	● (+.0050)	3	●	3	●	3	●	3	
9/16	12	4.331	1.024	—	0.429	0.322	0.4844	.5014			●	3	●	3	●	3	
5/8	11	4.331	1.063	—	0.480	0.360	0.5313	.5015	● (+.0050)	3	●	3	●	3	●	3	
3/4	10	4.921	1.181	—	0.590	0.442	0.6563	.5016	● (+.0050)	3	●	3	●	3	●	3	
7/8	9	5.512	1.260	—	0.697	0.523	0.7656	.5017			●	3	●	3	●	3	
1	8	6.299	1.417	—	0.800	0.600	0.8750	.5018									
1 1/8	7	7.087	1.575	—	0.896	0.672	0.9843	.5019									
1 1/4	7	7.087	1.575	—	1.021	0.766	1.1094	.5020									
1 3/8	6	7.874	1.969	—	1.108	0.831	1.2205	.5021									
1 1/2	6	7.874	1.969	—	1.233	0.925	1.3386	.5022									
1 3/4	5	8.661	2.283	—	1.430	1.072	1.5551	.5023									
2	4 1/2	9.843	2.559	—	1.644	1.233	1.7812	.5024									



3BX	NT	HSS Extra	B / approx. 3	O / P	max. 3 x d ₁		2BX	3BX	3BX	2BX	3BX	3BX	Class of Fit	Coating	Cutting Material	Technical Characteristics

M 4.1	N 2.8	S 2.3, 2.5-6					P 4.1-5.1	M 3.1-4.1	N 2.4-5, 2.7	S 1.1-2.2, 2.4	P 4.1-5.1	M 3.1-4.1	N 2.4-5, 2.7	S 1.1-2.2, 2.4	P 4.1-5.1	M 3.1-4.1	N 2.4-5, 2.7	S 1.1-2.2, 2.4	Applications – Material
--------------	--------------	---------------------	--	--	--	--	------------------	------------------	---------------------	-----------------------	------------------	------------------	---------------------	-----------------------	------------------	------------------	---------------------	-----------------------	-------------------------

BU206511	BU306001	BU306011	BU309611	BU456001	BU456011	BU459611	Tool Identification
-----------------	-----------------	-----------------	-----------------	-----------------	-----------------	-----------------	---------------------

Rekord 1B-AERO NT	Flutes	Rekord 1C-TI NT2	Flutes	Rekord 1C-TI NT2	Flutes	Rekord 1C-TI TICN	Flutes	Rekord 1D-TI NT2	Flutes	Rekord 1D-TI NT2	Flutes	Rekord 1D-TI TICN	Flutes	Dimens. ID	Nominal Size ø d ₁	T.P.I.
●	2	●	2	●	2	●	2	●	2	●	2	●	2	.5000	No. 1	64
●	2	●	2	●	2	●	2	●	2	●	2	●	2	.5001	No. 2	56
●	2	●	2	●	2	●	2	●	2	●	2	●	2	.5002	No. 3	48
●	3	●	3	●	3	●	3	●	3	●	3	●	3	.5003	No. 4	40
●	3	●	3	●	3	●	3	●	3	●	3	●	3	.5004	No. 5	40
●	3	●	3	●	3	●	3	●	3	●	3	●	3	.5005	No. 6	32
●	3	●	3	●	3	●	3	●	3	●	3	●	3	.5006	No. 8	32
●	3	●	3	●	3	●	3	●	3	●	3	●	3	.5007	No. 10	24
●	3	●	3	●	3	●	3	●	3	●	3	●	3	.5008	No. 12	24
●	3	●	3	●	3	●	3	●	3	●	3	●	3	.5009	1/4	20
●	3	●	3	●	3	●	3	●	3	●	3	●	3	.5010	5/16	18
●	3	●	3	●	3	●	3	●	3	●	3	●	3	.5011	3/8	16

Rekord 2B-AERO NT	Flutes	Rekord 2C-TI NT2	Flutes	Rekord 2C-TI NT2	Flutes	Rekord 2C-TI TICN	Flutes	Rekord 2D-TI NT2	Flutes	Rekord 2D-TI NT2	Flutes	Rekord 2D-TI TICN	Flutes	Dimens. ID	Nominal Size ø d ₁	T.P.I.
●	3	●	3	●	3	●	3	●	3	●	3	●	3	.5012	7/16	14
●	3	●	3	●	3	●	3	●	3	●	3	●	3	.5013	1/2	13
●	3	●	3	●	3	●	3	●	3	●	3	●	3	.5014	9/16	12
●	3	●	3	●	3	●	3	●	3	●	3	●	3	.5015	5/8	11
●	3	●	3	●	3	●	3	●	3	●	3	●	3	.5016	3/4	10
●	3	●	3	●	3	●	3	●	3	●	3	●	3	.5017	7/8	9
●	3	●	3	●	3	●	3	●	3	●	3	●	3	.5018	1	8
●	3	●	3	●	3	●	3	●	3	●	3	●	3	.5019	1 1/8	7
●	3	●	3	●	3	●	3	●	3	●	3	●	3	.5020	1 1/4	7
●	3	●	3	●	3	●	3	●	3	●	3	●	3	.5021	1 3/8	6
●	3	●	3	●	3	●	3	●	3	●	3	●	3	.5022	1 1/2	6
●	3	●	3	●	3	●	3	●	3	●	3	●	3	.5023	1 3/4	5
●	3	●	3	●	3	●	3	●	3	●	3	●	3	.5024	2	4 1/2

● = In stock
★ = Allow 7 days for delivery

Product Finder

V_c

UNC

UNF

UNEF

UN-8

MF

NPSM/NPSC

NPSF

Rp (BSPP)

G

NPT

NPTF

Rc (BSPT)

STI

SELF-LOCK

Accessories

Tech. Info



- Product Finder
- V_c
- UNC
- UNF
- UNEF
- UN-8
- M
- MF
- NPSM/NPSC
- NPSF
- Rp (BSPP)
- G
- NPT
- NPTF
- Rc (BSPT)
- STI
- SELF-LOCK
- Accessories
- Tech. Info

DIN Length - ANSI Shank

Overall length acc. to DIN 371, DIN 376

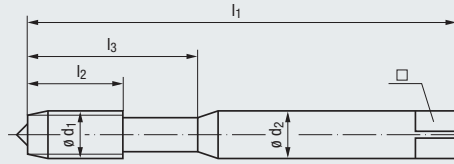

Reinforced Shank
(No.1 - 3/8)

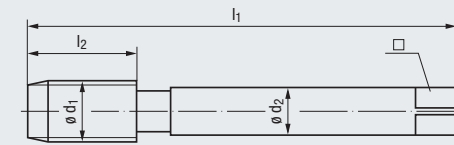

Reduced Shank
(7/16 - 2)



UNC
Unified Coarse Thread
ASME B1.1

Class of Fit
Coating
Cutting Material
Technical Characteristics



Thread Depth and Hole Shape

Applications - Material

NI
Nickel
Alloys



H
Materials of High
Tensile Strength









3BX	3BX	2BX	2BX
TICN	TICN	NT	TICN
HSSE-PM	HSSE-PM	HSS Extra	HSS Extra
L08	R10	C / 2-3	C / 2-3
D / 4-5	C / 2-3	E / O / P	E / O / P
O / P	O / P		
max. 3 x d ₁	max. 2 x d ₁	max. 2 x d ₁	
M 4.1	M 4.1	P 1.1-3.1	P 1.1-4.1
N 2.8	N 2.8	K 1.1-4.2	K 1.1-4.2
S 1.2-3	S 1.2-3	N 2.4-7	N 2.4-7
S 2.3, 2.5-6	S 2.3, 2.5-6	N 4.1, 5.1	N 4.1, 5.1

Reinforced Shank

Nominal Size ø d ₁	T.P.I.	l ₁	l ₂	inch		ø d ₂	□	Tool Identification	BU30J411		BU35J411		BU100501		BU109101	
				Rekord 1C-NI-PM TICN	Flutes				Rekord 1DF-NI-PM TICN	Flutes	Rekord 1A-H NT	Flutes	Rekord 1A-H TICN	Flutes		
No. 1	64	1.772	0.276	0.472	0.141	0.110	0.0595	.5000					●	2		
No. 2	56	1.772	0.276	0.472	0.141	0.110	0.0700	.5001					●	3	●	3
No. 3	48	1.969	0.354	0.551	0.141	0.110	0.0820	.5002					●	3		
No. 4	40	2.205	0.433	0.709	0.141	0.110	0.0890	.5003	●	2	●	2	●	3	●	3
No. 5	40	2.205	0.433	0.709	0.141	0.110	0.1015	.5004	●	2	●	2	●	3		
No. 6	32	2.205	0.472	0.787	0.141	0.110	0.1110	.5005	●	3	●	3	●	3	●	3
No. 8	32	2.480	0.512	0.827	0.168	0.131	0.1360	.5006	●	3	●	3	●	3	●	3
No.10	24	2.756	0.591	0.984	0.194	0.152	0.1520	.5007	●	3	●	3	●	3	●	3
No.12	24	3.150	0.630	1.142	0.220	0.165	0.1770	.5008	●	3	●	3	●	3		
1/4	20	3.150	0.669	1.181	0.255	0.191	0.2040 2)	.5009	●	3	●	3	●	3	●	3
5/16	18	3.543	0.787	1.378	0.318	0.238	0.2610 2)	.5010	●	3	●	3	●	3	●	3
3/8	16	3.937	0.866	1.535	0.381	0.286	0.3160 2)	.5011	●	3	●	3	●	3	●	3

Reduced Shank

Nominal Size ø d ₁	T.P.I.	l ₁	l ₂	inch		ø d ₂	□	Tool Identification	CU30J411		CU35J411		CU100501		CU109101	
				Rekord 2C-NI-PM TICN	Flutes				Rekord 2DF-NI-PM TICN	Flutes	Rekord 2A-H NT	Flutes	Rekord 2A-H TICN	Flutes		
7/16	14	3.937	0.866	—	0.323	0.242	0.3680 2)	.5012	●	3	●	3	●	3	●	3
1/2	13	4.331	0.984	—	0.367	0.275	0.4219 2)	.5013	●	3	●	3	●	3	●	3
9/16	12	4.331	1.024	—	0.429	0.322	0.4844	.5014	●	3	●	3	●	3	●	3
5/8	11	4.331	1.063	—	0.480	0.360	0.5313	.5015	●	3	●	3	●	3	●	3
3/4	10	4.921	1.181	—	0.590	0.442	0.6563	.5016	●	3	●	3	●	4	●	4
7/8	9	5.512	1.260	—	0.697	0.523	0.7656	.5017	●	3	●	3	●	4	●	4
1	8	6.299	1.417	—	0.800	0.600	0.8750	.5018					●	4	●	4
1 1/8	7	7.087	1.575	—	0.896	0.672	0.9843	.5019								
1 1/4	7	7.087	1.575	—	1.021	0.766	1.1094	.5020								
1 3/8	6	7.874	1.969	—	1.108	0.831	1.2205	.5021								
1 1/2	6	7.874	1.969	—	1.233	0.925	1.3386	.5022								
1 3/4	5	8.661	2.283	—	1.430	1.072	1.5551	.5023								
2	4 1/2	9.843	2.559	—	1.644	1.233	1.7812	.5024								

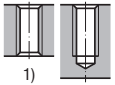
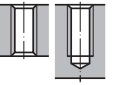
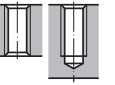
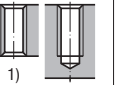
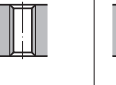
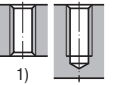
H Materials of High Tensile Strength		HCUT Hardened Steels		Z CNC-Controlled Machines						
										
2BX TICN HSS Extra		2BX TICN HSSE-PM		2BX TICN HSS Extra	2BX TICN HSS Extra	2BX TICN HSS Extra	2BX TICN HSS Extra	Class of Fit Coating Cutting Material Technical Characteristics		
C / 2-3 E / O		C / 2-3 O / P		C / 2-3 E / O / P	C / 2-3 E / O	C / 2-3 E / O	E / 1.5-2 E / O			
max. 2 x d ₁ 		max. 1.5 x d ₁ 		max. 2 x d ₁ 	max. 2 x d ₁ 	max. 2 x d ₁ 	max. 2 x d ₁ 	Thread Depth and Hole Shape		
P 1.1-4.1 K 1.1-4.2 N 2.4-7 N 4.1, 5.1		H 1.1-2		P 1.1-4.1 K 1.1-4.2 N 1.4-6, 2.4-7 N 4.1	P 1.1-4.1 K 1.1-4.2 N 1.4-6, 2.4-7 N 4.1	P 1.1-4.1 K 1.1-4.2 N 1.4-6, 2.4-7 N 4.1	P 1.1-4.1 K 1.1-4.2 N 1.4-6, 2.4-7 N 4.1	Applications – Material		
BU959101		BU10J901		BU109401	BU959401	BU219401	BU969401	Tool Identification		
Rekord 1A-H-IKZ TICN	Flutes	Rekord 1A-HCUT-PM TICN	Flutes	Rekord 1A-Z TICN	Rekord 1A-Z-IKZ TICN	Rekord 1A-Z-IKZN TICN	Rekord 1A-Z/E-IKZ TICN	Dimens. ID	Nominal Size ø d ₁	T.P.I.
●	3			●	●	●	●	.5000	No. 1	64
								.5001	No. 2	56
								.5002	No. 3	48
				●				.5003	No. 4	40
				●				.5004	No. 5	40
				●				.5005	No. 6	32
				●				.5006	No. 8	32
●	3			●	●	●	●	.5007	No. 10	24
								.5008	No. 12	24
●	3	●	4	●	●	●	●	.5009	1/4	20
●	3	●	5	●	●	●	●	.5010	5/16	18
●	3	●	5	●	●	●	●	.5011	3/8	16
CU959101		CU10J901		CU109401	CU959401	CU219401	CU969401	Tool Identification		
Rekord 2A-H-IKZ TICN	Flutes	Rekord 2A-HCUT-PM TICN	Flutes	Rekord 2A-Z TICN	Rekord 2A-Z-IKZ TICN	Rekord 2A-Z-IKZN TICN	Rekord 2A-Z/E-IKZ TICN	Dimens. ID	Nominal Size ø d ₁	T.P.I.
●	3	●	5	●	●	●	●	.5012	7/16	14
●	3	●	5	●	●	●	●	.5013	1/2	13
●	3			●	●	●	●	.5014	9/16	12
●	3			●	●	●	●	.5015	5/8	11
●	4			●	●	●	●	.5016	3/4	10
●	4			●	●	●	●	.5017	7/8	9
●	4			●	●	●	●	.5018	1	8
								.5019	1 1/8	7
								.5020	1 1/4	7
								.5021	1 3/8	6
								.5022	1 1/2	6
								.5023	1 3/4	5
								.5024	2	4 1/2

● = In stock
★ = Allow 7 days for delivery

1) Threading in through holes is possible only with external cooling/lubrication
2) Increase drill diameter for taps Rekord 1/2A-HCUT-PM-TICN by 0.004 in

Product Finder

V_c

UNC

UNF

UNEF

UN-8

MF

NPSM/NPSC

NPSF

Rp (BSPP)

G

NPT

NPTF

Rc (BSPT)

STI

SELF-LOCK

Accessories

Tech. Info



- Product Finder
- V_c
- UNC
- UNF
- UNEF
- UN-8
- M
- MF
- NPSM/NPSC
- NPSF
- Rp (BSPP)
- G
- NPT
- NPTF
- Rc (BSPT)
- STI
- SELF-LOCK
- Accessories
- Tech. Info

DIN Length - ANSI Shank

Overall length acc. to DIN 371, DIN 376

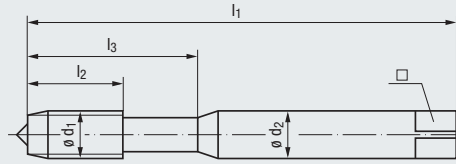

Reinforced Shank
(No.1 - 3/8)

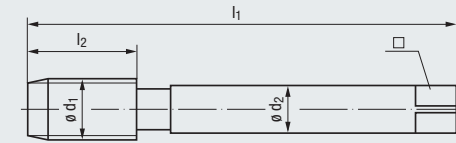

Reduced Shank
(7/16 - 2)



UNC
Unified Coarse Thread
ASME B1.1

Class of Fit

Coating

Cutting Material

Technical Characteristics



Thread Depth
and Hole Shape

Applications - Material

Z
CNC-Controlled
Machines



2BX	2BX	2BX	3BX	2BX
TIN-70	GLT-1	TIN-70	GLT-1	TIN
HSSE-PM	HSSE-PM	HSSE-PM	HSSE-PM	HSS Extra
B / 4-5	B / 4-5	B / 4-5	B / 4-5	R15
E / O / P	E / O / P	E / O	E / O / P	C / 2-3
				E / O / P

max. 3 x d₁



max. 2 x d₁



P 1.1-5.1	P 1.1-5.1	P 1.1-5.1	P 1.1-5.1	P 2.1-5.1
M 1.1-3.1	M 1.1-3.1	M 1.1-3.1	M 1.1-3.1	K 2.1-2
K 2.1	K 2.1	K 2.1	K 2.1	N 1.4-6, 2.4-5
N 1.4-2.2, 2.4-5	N 1.4-2.2, 2.4-5	N 1.4-2.2, 2.4-5	N 1.4-2.2, 2.4-5	
S 1.1	S 1.1	S 1.1	S 1.1	

Reinforced Shank

Nominal Size ø d ₁	T.P.I.	l ₁	l ₂	inch		ø d ₂	□	Tool Identification		BU208F01		BU20A601		BU088F01		BU20A611		BU453701	
				l ₃	□			Rekord 1B-Z-PM TIN-70	Flutes	Rekord 1B-Z-PM GLT-1	Flutes	Rekord 1B-Z-PM PM-TIN-70	Flutes	Rekord 1B-Z-PM GLT-1	Flutes	Rekord 1D-Z TIN	Flutes		
No. 1	64	1.772	0.157	0.472	0.141	0.110	0.0595	.5000											
No. 2	56	1.772	0.177	0.472	0.141	0.110	0.0700	.5001											
No. 3	48	1.969	0.197	0.551	0.141	0.110	0.0820	.5002											
No. 4	40	2.205	0.236	0.709	0.141	0.110	0.0890	.5003	●	2	●	2				●	2	●	2
No. 5	40	2.205	0.276	0.709	0.141	0.110	0.1015	.5004											
No. 6	32	2.205	0.276	0.787	0.141	0.110	0.1110	.5005	●	3	●	3				●	3	●	3
No. 8	32	2.480	0.315	0.827	0.168	0.131	0.1360	.5006	●	3	●	3				●	3	●	3
No. 10	24	2.756	0.394	0.984	0.194	0.152	0.1520	.5007	●	3	●	3	●	3		●	3	●	3
No. 12	24	3.150	0.394	1.142	0.220	0.165	0.1770	.5008											
1/4	20	3.150	0.512	1.181	0.255	0.191	0.2040	.5009	●	3	●	3	●	3		●	3	●	3
5/16	18	3.543	0.551	1.378	0.318	0.238	0.2610	.5010	●	4	●	4	●	4		●	4	●	3
3/8	16	3.937	0.630	1.535	0.381	0.286	0.3160	.5011	●	4	●	4	●	4		●	4	●	3

Reduced Shank

Nominal Size ø d ₁	T.P.I.	l ₁	l ₂	inch		ø d ₂	□	Tool Identification		CU208F01		CU20A601		CU088F01		CU20A611		CU453701		
				l ₃	□			Rekord 2B-Z-PM TIN-70	Flutes	Rekord 2B-Z-PM GLT-1	Flutes	Rekord 2B-Z-PM PM-TIN-70	Flutes	Rekord 2B-Z-PM GLT-1	Flutes	Rekord 2D-Z TIN	Flutes			
7/16	14	3.937	0.709	—	0.323	0.242	0.3680	.5012	●	4	●	4	●	4	●	4	●	4	●	3
1/2	13	4.331	0.787	—	0.367	0.275	0.4219	.5013	●	4	●	4	●	4	●	4	●	4	●	3
9/16	12	4.331	0.787	—	0.429	0.322	0.4844	.5014	●	4	●	4	●	4	●	4	●	4	●	3
5/8	11	4.331	0.866	—	0.480	0.360	0.5313	.5015	●	4	●	4	●	4	●	4	●	4	●	3
3/4	10	4.921	0.984	—	0.590	0.442	0.6563	.5016	●	4	●	4	●	4	●	4	●	4	●	3
7/8	9	5.512	1.063	—	0.697	0.523	0.7656	.5017												
1	8	6.299	1.181	—	0.800	0.600	0.8750	.5018												
1 1/8	7	7.087	1.378	—	0.896	0.672	0.9843	.5019												
1 1/4	7	7.087	1.378	—	1.021	0.766	1.1094	.5020												
1 3/8	6	7.874	1.575	—	1.108	0.831	1.2205	.5021												
1 1/2	6	7.874	1.575	—	1.233	0.925	1.3386	.5022												
1 3/4	5	8.661	1.772	—	1.430	1.072	1.5551	.5023												
2	4 1/2	9.843	1.969	—	1.644	1.233	1.7812	.5024												

Z
CNC-Controlled
Machines

2BX	2BX	2BX	2B	2B	2B	2B	2B
TIN	TIN	TIN	TIN	GLT-1	GLT-1	TIN	TIN
HSS Extra	HSS Extra	HSS Extra	HSS Extra	HSS Extra	HSS Extra	HSS Extra	HSS Extra
R15	R15	R15	R45	R45	R45	R45	R45
C / 2-3	C / 2-3	C / 2-3	C / 2-3	C / 2-3	C / 2-3	E / 1.5-2	E / 1.5-2
E / O	E / O / P	E / O	E / O / P	E / O / P	E / O	E / O / P	E / O / P

- Product Finder
- V_c
- UNC
- UNF
- UNEF
- UN-8
- MF
- NPSM/NPSC
- NPSF
- R_p (BSPP)
- G
- NPT
- NPTF
- Rc (BSPT)
- STI
- SELF-LOCK
- Accessories
- Tech. Info

max. 2 x d ₁ 			max. 3 x d ₁ 				
-----------------------------	--	--	-----------------------------	--	--	--	--

P 2.1-5.1 K 2.1-2 N 1.4-6, 2.4-5	P 2.1-5.1 K 2.1-2 N 1.4-6, 2.4-5	P 2.1-5.1 K 2.1-2 N 1.4-6, 2.4-5	P 1.1-4.1 M 1.1-3.1 N 1.4-6 N 2.1-2, 2.4-5 S 1.1	P 1.1-4.1 M 1.1-3.1 N 1.4-6 N 2.1-2, 2.4-5 S 1.1	P 1.1-4.1 M 1.1-3.1 N 1.4-6 N 2.1-2, 2.4-5 S 1.1	P 1.1-4.1 M 1.1-2.1 N 2.1 N 1.4-6 N 2.1-2, 2.4-5 S 1.1	P 1.1-4.1 M 1.1-3.1 N 1.4-6 N 2.1-2, 2.4-5 S 1.1
---	---	---	---	---	---	---	---

BU973701		BU523701		BU573701		BU50C400		BU94C400		BU513500		BU513700		Tool Identification		
Rekord 1D-Z- IKZ TIN	Flutes	Rekord 1D-Z- BF TIN	Flutes	Rekord 1D-Z- BF IKZ-TIN	Flutes	Enorm 1-Z GLT-1	Flutes	Enorm 1-Z- IKZ GLT-1	Flutes	Enorm 1-Z/E	Flutes	Enorm 1-Z/E TIN	Flutes	Dimens. ID	Nominal Size ø d ₁	T.P.I.
●	2									●	2	●	2	.5000	No. 1	64
										●	2	●	2	.5001	No. 2	56
										●	2	●	2	.5002	No. 3	48
		●	2			●	2	●	2	●	2	●	2	.5003	No. 4	40
		●	2			●	3	●	3	●	3	●	3	.5004	No. 5	40
		●	3			●	3	●	3	●	3	●	3	.5005	No. 6	32
		●	3			●	3	●	3	●	3	●	3	.5006	No. 8	32
●	3	●	3	●	3	●	3	●	3	●	3	●	3	.5007	No. 10	24
										●	3	●	3	.5008	No. 12	24
●	3	●	3	●	3	●	3	●	3	●	3	●	3	.5009	1/4	20
●	3	●	3	●	3	●	3	●	3	●	3	●	3	.5010	5/16	18
●	3	●	3	●	3	●	3	●	3	●	3	●	3	.5011	3/8	16

CU973701		CU573701		CU583701		CU503700		CU50C400		CU94C400		CU513500		CU513700		Tool Identification		
Rekord 2D-Z- IKZ TIN	Flutes	Rekord 2D-Z- BF TIN	Flutes	Rekord 2D-Z- BF IKZ-TIN	Flutes	Enorm 2-Z TIN	Flutes	Enorm 2-Z GLT-1	Flutes	Enorm 2-Z- IKZ GLT-1	Flutes	Enorm 2-Z/E	Flutes	Enorm 2-Z/E TIN	Flutes	Dimens. ID	Nominal Size ø d ₁	T.P.I.
●	3	●	3	●	3			●	4	●	4	●	4	●	4	.5012	7/16	14
●	3	●	3	●	3			●	4	●	4	●	4	●	4	.5013	1/2	13
●	3	●	3	●	3			●	4	●	4	●	4	●	4	.5014	9/16	12
●	3	●	3	●	3			●	4	●	4	●	4	●	4	.5015	5/8	11
●	3	●	3	●	3			●	4	●	4	●	4	●	4	.5016	3/4	10
		●	3	●	3			●	4	●	4	●	4	●	5	.5017	7/8	9
		●	3	●	3			●	5	●	5	●	5	●	5	.5018	1	8
		●	3	●	3	●	5	●	5	●	5			●	5	.5019	1 1/8	7
		●	4	●	4	●	5	●	5	●	5			●	5	.5020	1 1/4	7
				●	4	●	5	●	5	●	5			●	5	.5021	1 3/8	6
				●	4	●	5	●	5	●	5			●	5	.5022	1 1/2	6
						●	6	●	6	●	6			●	5	.5023	1 3/4	5
						●	6	●	6	●	6			●	5	.5024	2	4 1/2

● = In stock
★ = Allow 7 days for delivery

- Product Finder
- V_c
- UNC
- UNF
- UNEF
- UN-8
- M
- MF
- NPSM/NPSC
- NPSF
- Rp (BSPP)
- G
- NPT
- NPTF
- Rc (BSPT)
- STI
- SELF-LOCK
- Accessories
- Tech. Info

DIN Length - ANSI Shank

Overall length acc. to DIN 371, DIN 376

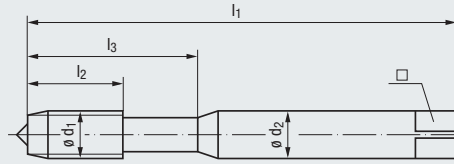

Reinforced Shank
(No. 1 - 3/8)

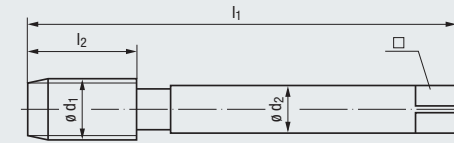

Reduced Shank
(7/16 - 2)

UNC



Unified Coarse Thread
ASME B1.1

Class of Fit

Coating

Cutting Material

Technical Characteristics



Thread Depth
and Hole Shape

Applications - Material

Z
CNC-Controlled
Machines



2B	2B	2B	2B	3B
TICN	GLT-1	TICN	GLT-1	GLT-1
HSS Extra	HSS Extra	HSS Extra	HSS Extra	HSS Extra
R45	R45	R45	R45	R45
E / 1.5-2	E / 1.5-2	E / 1.5-2	E / 1.5-2	E / 1.5-2
E / O / P	E / O / P	E / O	E / O	E / O / P

max. 3 x d₁



P 1.1-4.1	P 1.1-4.1	P 1.1-4.1	P 1.1-4.1	P 1.1-4.1
M 1.1-3.1	M 1.1-3.1	M 1.1-3.1	M 1.1-3.1	M 1.1-3.1
N 1.4-6	N 1.4-6	N 1.4-6	N 1.4-6	N 1.4-6
N 2.1-2, 2.4-5	N 2.1-2, 2.4-5	N 2.1-2, 2.4-5	N 2.1-2, 2.4-5	N 2.1-2, 2.4-5
S 1.1	S 1.1	S 1.1	S 1.1	S 1.1

Reinforced Shank

Nominal Size ø d ₁	T.P.I.	l ₁	l ₂	inch		ø d ₂	□	Tool Identification		BU519400		BU51C400		BU999400		BU99C400		BU51C410	
				l ₃	□			Enorm 1-Z/E TICN	Flutes	Enorm 1-Z/E GLT-1	Flutes	Enorm 1-Z/E-IKZ TICN	Flutes	Enorm 1-Z/E-IKZ GLT-1	Flutes	Enorm 1-Z/E GLT-1	Flutes		
No. 1	64	1.772	0.157	0.472	0.141	0.110		0.0595	.5000										
No. 2	56	1.772	0.177	0.472	0.141	0.110		0.0700	.5001										
No. 3	48	1.969	0.197	0.551	0.141	0.110		0.0820	.5002										
No. 4	40	2.205	0.236	0.709	0.141	0.110		0.0890	.5003	●	2	●	2					●	2
No. 5	40	2.205	0.276	0.709	0.141	0.110		0.1015	.5004	●	3	●	3					●	3
No. 6	32	2.205	0.276	0.787	0.141	0.110		0.1110	.5005	●	3	●	3					●	3
No. 8	32	2.480	0.315	0.827	0.168	0.131		0.1360	.5006	●	3	●	3					●	3
No. 10	24	2.756	0.394	0.984	0.194	0.152		0.1520	.5007	●	3	●	3	●	3	●	3	●	3
No. 12	24	3.150	0.394	1.142	0.220	0.165		0.1770	.5008										
1/4	20	3.150	0.512	1.181	0.255	0.191		0.2040	.5009	●	3	●	3	●	3	●	3	●	3
5/16	18	3.543	0.551	1.378	0.318	0.238		0.2610	.5010	●	3	●	3	●	3	●	3	●	3
3/8	16	3.937	0.630	1.535	0.381	0.286		0.3160	.5011	●	3	●	3	●	3	●	3	●	3

Reduced Shank

Nominal Size ø d ₁	T.P.I.	l ₁	l ₂	inch		ø d ₂	□	Tool Identification		CU519400		CU51C400		CU999400		CU99C400		CU51C410	
				l ₃	□			Enorm 2-Z/E TICN	Flutes	Enorm 2-Z/E GLT-1	Flutes	Enorm 2-Z/E-IKZ TICN	Flutes	Enorm 2-Z/E-IKZ GLT-1	Flutes	Enorm 2-Z/E GLT-1	Flutes		
7/16	14	3.937	0.709	—	0.323	0.242		0.3680	.5012	●	4	●	4	●	4	●	4	●	4
1/2	13	4.331	0.787	—	0.367	0.275		0.4219	.5013	●	4	●	4	●	4	●	4	●	4
9/16	12	4.331	0.787	—	0.429	0.322		0.4844	.5014	●	4	●	4	●	4	●	4	●	4
5/8	11	4.331	0.866	—	0.480	0.360		0.5313	.5015	●	4	●	4	●	4	●	4	●	4
3/4	10	4.921	0.984	—	0.590	0.442		0.6563	.5016	●	4	●	4	●	4	●	4	●	4
7/8	9	5.512	1.063	—	0.697	0.523		0.7656	.5017	●	5	●	5	●	5	●	5	●	5
1	8	6.299	1.181	—	0.800	0.600		0.8750	.5018	●	5	●	5	●	5	●	5	●	5
1 1/8	7	7.087	1.378	—	0.896	0.672		0.9843	.5019										
1 1/4	7	7.087	1.378	—	1.021	0.766		1.1094	.5020										
1 3/8	6	7.874	1.575	—	1.108	0.831		1.2205	.5021										
1 1/2	6	7.874	1.575	—	1.233	0.925		1.3386	.5022										
1 3/4	5	8.661	1.772	—	1.430	1.072		1.5551	.5023										
2	4 1/2	9.843	1.969	—	1.644	1.233		1.7812	.5024										

Z
CNC-Controlled
Machines

new



SPEED
High-Speed
Cutting

new

new



- 3B**
- GLT-1
- HSS Extra
- R45
- E / 1.5-2**
- E / O

- | | | | | | | |
|------------|------------|------------------|------------|----------------|----------------|------------|
| 2BX | 2BX | 2BX | 2BX | 2BX | 2BX | 2BX |
| TICN | TICN | TICN | TICN | TIN-70 | TIN-70 | TIN |
| HSS Extra | HSS Extra | HSS Extra | HSS Extra | HSSE-PM | HSSE-PM | HSS Extra |
| C / 2-3 | C / 2-3 | E / 1.5-2 | B / 4-5 | B / 4-5 | C / 2-3 | R15 |
| E | E | E | E | E | E | E |

Class of Fit
Coating
Cutting Material
Technical Characteristics

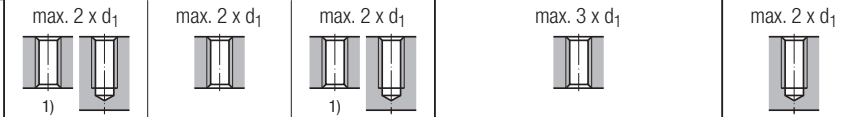
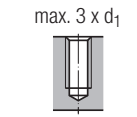

Thread Depth
and Hole Shape

- P 1.1-4.1**
- M 1.1-3.1**
- N 1.4-6**
- N 2.1-2, 2.4-5**
- S 1.1**

- | | | | | | |
|------------------|------------------|------------------|------------------|------------------|------------------|
| K 1.1-4.2 | K 1.1-4.2 | K 1.1-4.2 | P 1.1-4.1 | P 1.1-4.1 | P 1.1-4.1 |
| N 1.4-6 | N 1.4-6 | N 1.4-6 | K 2.1-2 | K 2.1-2 | M 1.1-3.1 |
| | | | N 1.4-6 | N 1.4-6 | K 2.1-2 |
| | | | | | N 1.4-2.1 |

Applications – Material

BU99C410		BW159401		BW179401		BW169401		BW138F01		BW208F01		BU263701		Tool Identification		
Enorm 1-Z/E-IKZ GLT-1	Flutes	Rekord 1A-SPEED IKZ-TICN	Flutes	Rekord 1A-SPEED IKZN-TICN	Flutes	Rekord 1A-SPEED/E IKZ-TICN	Flutes	Rekord 1B-Z-SPEED PM-TIN-70	Flutes	Rekord 1B-Z-SPEED IKZN-PM TIN-70	Flutes	Rekord 1D-SPEED TIN	Flutes	Dimens. ID	Nominal Size ø d ₁	T.P.I.
														.5000	No. 1	64
														.5001	No. 2	56
														.5002	No. 3	48
								●	2			●	2	.5003	No. 4	40
								●	3			●	2	.5004	No. 5	40
								●	3			●	3	.5005	No. 6	32
								●	3			●	3	.5006	No. 8	32
●	3							●	3	●	3	●	3	.5007	No. 10	24
														.5008	No. 12	24
●	3	●	3	●	3	●	3	●	3	●	3	●	3	.5009	1/4	20
●	3	●	3	●	3	●	3	●	4	●	4	●	3	.5010	5/16	18
●	3	●	3	●	3	●	3	●	4	●	4	●	3	.5011	3/8	16

CU99C410		CW159401		CW179401		CW169401		CW138F01		CW208F01		CU263701		Tool Identification		
Enorm 2-Z/E-IKZ GLT-1	Flutes	Rekord 2A-SPEED IKZ-TICN	Flutes	Rekord 2A-SPEED IKZN-TICN	Flutes	Rekord 2A-SPEED/E IKZ-TICN	Flutes	Rekord 2B-Z-SPEED PM-TIN-70	Flutes	Rekord 2B-Z-SPEED IKZN-PM TIN-70	Flutes	Rekord 2D-SPEED TIN	Flutes	Dimens. ID	Nominal Size ø d ₁	T.P.I.
●	4	●	3	●	3	●	3	●	4	●	4	●	3	.5012	7/16	14
●	4	●	3	●	3	●	3	●	4	●	4	●	3	.5013	1/2	13
●	4	●	3	●	3	●	3	●	4	●	4	●	3	.5014	9/16	12
●	4	●	3	●	3	●	3	●	4	●	4	●	3	.5015	5/8	11
●	4	●	4	●	4	●	4	●	4	●	4	●	3	.5016	3/4	10
		●	4	●	4	●	4							.5017	7/8	9
		●	4	●	4	●	4							.5018	1	8
														.5019	1 1/8	7
														.5020	1 1/4	7
														.5021	1 3/8	6
														.5022	1 1/2	6
														.5023	1 3/4	5
														.5024	2	4 1/2

● = In stock
★ = Allow 7 days for delivery

1) Threading in through holes is possible only with external cooling/lubrication



Product Finder

- V_c
- UNC
- UNF
- UNEF
- UN-8
- MF
- NPSM/NPSC
- NPSF
- R_p (BSPP)
- G
- NPT
- NPTF
- R_c (BSPT)
- STI
- SELF-LOCK
- Accessories
- Tech. Info



- Product Finder
- V_c
- UNC
- UNF
- UNEF
- UN-8
- M
- MF
- NPSM/NPSC
- NPSF
- Rp (BSPP)
- G
- NPT
- NPTF
- Rc (BSPT)
- STI
- SELF-LOCK
- Accessories
- Tech. Info

DIN Length - ANSI Shank

Overall length acc. to DIN 371, DIN 376

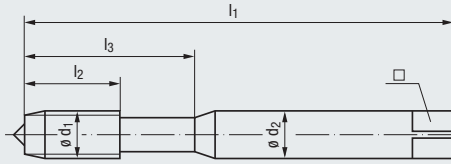

Reinforced Shank
(No.1 - 3/8)

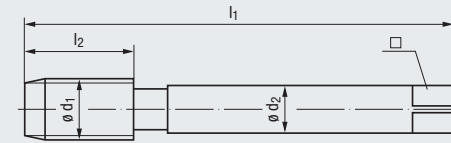

Reduced Shank
(7/16 - 2)



SPEED
High-Speed
Cutting



UNC
Unified Coarse Thread
ASME B1.1

Class of Fit
Coating
Cutting Material
Technical Characteristics

Thread Depth
and Hole Shape

Applications - Material

2BX	2B
TIN	TIN
HSS Extra	HSS Extra
R15	R45
C / 2-3	C / 2-3
E	E

max. 2 x d ₁	max. 3 x d ₁

P 1.1-4.1	P 1.1-4.1
M 1.1-3.1	M 1.1-3.1
K 2.1-2	K 2.1
N 1.4-2.1	N 1.1-2.2

Reinforced Shank

								Tool Identification		BU293701		BW553700	
Nominal Size ø d ₁	T.P.I.	l ₁	l ₂	inch		□		Dimens. ID	Rekord	Enorm	Flutes	Flutes	
				1D-SPEED	1-SPEED				IKZ-TIN	IKZ-TIN			
No. 1	64	1.772	0.157	0.472	0.141	0.110	0.0595	.5000					
No. 2	56	1.772	0.177	0.472	0.141	0.110	0.0700	.5001					
No. 3	48	1.969	0.197	0.551	0.141	0.110	0.0820	.5002					
No. 4	40	2.205	0.236	0.709	0.141	0.110	0.0890	.5003					
No. 5	40	2.205	0.276	0.709	0.141	0.110	0.1015	.5004					
No. 6	32	2.205	0.276	0.787	0.141	0.110	0.1110	.5005					
No. 8	32	2.480	0.315	0.827	0.168	0.131	0.1360	.5006					
No.10	24	2.756	0.394	0.984	0.194	0.152	0.1520	.5007	●	●	3		
No.12	24	3.150	0.394	1.142	0.220	0.165	0.1770	.5008					
1/4	20	3.150	0.512	1.181	0.255	0.191	0.2040	.5009	●	●	3	3	
5/16	18	3.543	0.551	1.378	0.318	0.238	0.2610	.5010	●	●	3	3	
3/8	16	3.937	0.630	1.535	0.381	0.286	0.3160	.5011	●	●	3	3	

Reduced Shank

								Tool Identification		CU293701		CW553700	
Nominal Size ø d ₁	T.P.I.	l ₁	l ₂	inch		□		Dimens. ID	Rekord	Enorm	Flutes	Flutes	
				2D-SPEED	2-SPEED				IKZ-TIN	IKZ-TIN			
7/16	14	3.937	0.709	—	0.323	0.242	0.3680	.5012	●	●	3	4	
1/2	13	4.331	0.787	—	0.367	0.275	0.4219	.5013	●	●	3	4	
9/16	12	4.331	0.787	—	0.429	0.322	0.4844	.5014					
5/8	11	4.331	0.866	—	0.480	0.360	0.5313	.5015	●	●	3	4	
3/4	10	4.921	0.984	—	0.590	0.442	0.6563	.5016	●	●	3	4	
7/8	9	5.512	1.063	—	0.697	0.523	0.7656	.5017					
1	8	6.299	1.181	—	0.800	0.600	0.8750	.5018					
1 1/8	7	7.087	1.378	—	0.896	0.672	0.9843	.5019					
1 1/4	7	7.087	1.378	—	1.021	0.766	1.1094	.5020					
1 3/8	6	7.874	1.575	—	1.108	0.831	1.2205	.5021					
1 1/2	6	7.874	1.575	—	1.233	0.925	1.3386	.5022					
1 3/4	5	8.661	1.772	—	1.430	1.072	1.5551	.5023					
2	4 1/2	9.843	1.969	—	1.644	1.233	1.7812	.5024					

DIN Length • ANSI Shank

Overall length acc. to DIN 376

With internal chip collector

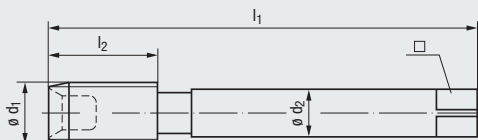

Reduced Shank

VA
Stainless Steel
Materials



UNC

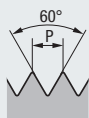

**Unified Coarse Thread
ASME B1.1**

Class of Fit
Coating
Cutting Material
Technical Characteristics



- 3BX 2)**
- NE2
- HSS Extra
- C / 2-3
- P / O 1)

Thread Depth
and Hole Shape

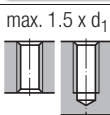

Applications – Material

- P 1.1-4.1**
- M 1.1-2.1**
- K 1.1-4.2**

Reduced Shank

Tool Identification

CU803011

Nominal Size ø d ₁	T.P.I.	inch				□	Image	Dimens. ID	Robust 2X-VA NE2	Flutes
		l ₁	l ₂	ø d ₂						
3/4	10	4.921	1.181	0.590	0.442	0.6563	.5016	●	5	
7/8	9	5.512	1.260	0.697	0.523	0.7656	.5017	●	5	
1	8	6.299	1.417	0.800	0.600	0.8750	.5018	●	5	
1 1/8	7	7.087	1.575	0.896	0.672	0.9843	.5019	●	5	
1 1/4	7	7.087	1.575	1.021	0.766	1.1094	.5020	●	6	
1 3/8	6	7.874	1.969	1.108	0.831	1.2205	.5021	●	6	
1 1/2	6	7.874	1.969	1.233	0.925	1.3386	.5022	●	6	
1 3/4	5	8.661	2.283	1.430	1.072	1.5551	.5023	●	6	
2	4 1/2	9.843	2.559	1.644	1.233	1.7812	.5024	●	6	

1) If possible, use paste lubrication, coating both the tool and the walls of the drilled hole. Lubrication with oil is possible only in the vertical machining of blind holes, if the hole is entirely filled with oil.

2) Class 2B threads may be produced with 3BX taps.

Larger sizes priced upon request. We have experience in making taps as large as 10 inches ø UN.

The Complete Tool System

Robust 2X-VA Taps when used with a KSN Type tapping attachment creates the optimal tapping unit!

- Product Finder
- V_c
- UNC
- UNF
- UNEF
- UN-8
- ...
- MF
- NPSM/NPSC
- NPSF
- R_p (BSPP)
- G
- NPT
- NPTF
- R_c (BSPT)
- STI
- SELF-LOCK
- Accessories
- Tech. Info



- Product Finder
- V_c
- UNC
- UNF
- UNEF
- UN-8
- M
- MF
- NPSM/NPSC
- NPSF
- Rp (BSPP)
- G
- NPT
- NPTF
- Rc (BSPT)
- STI
- SELF-LOCK
- Accessories
- Tech. Info

ANSI Length • ANSI Shank

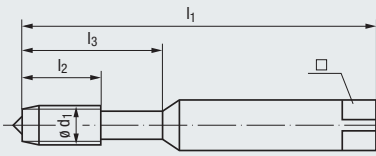

Reinforced Shank
(No.4 - 3/8)

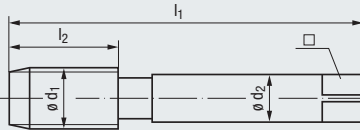

Reduced Shank
(7/16 - 3/4)

STEEL
Steel
Materials



VA
Stainless Steel
Materials



UNC

**Unified Coarse Thread
ASME B1.1**

Class of Fit: 2B
Coating: TIN
Cutting Material: HSS Extra
Technical Characteristics: B / 4-5, E / O

Thread Depth and Hole Shape: max. 3 x d₁

Applications – Material

2B	2B	3B	Override
TIN	NT	NT	NT
HSS Extra	HSS Extra	HSS Extra	HSS Extra
B / 4-5	B / 4-5	B / 4-5	B / 4-5
E / O	E / O / P	E / O / P	E / O / P

max. 3 x d ₁	max. 3 x d ₁	max. 3 x d ₁	max. 3 x d ₁
-------------------------	-------------------------	-------------------------	-------------------------

P 1.1-4.1	P 1.1-3.1	P 1.1-3.1	P 1.1-3.1
K 2.1	M 1.1-2.1	M 1.1-2.1	M 1.1-2.1
N 2.2, 2.4-5	K 2.1	K 2.1	K 2.1
	N 2.2, 2.5-6	N 2.2, 2.5-6	N 2.2, 2.5-6

Nominal Size ø d ₁	T.P.I.	inch						□	Tool Identification	AU208400		AU203000		AU203010		AU203044	
		l ₁	l ₂	l ₃	ø d ₂	ø d ₂	□			Rekord B-STEEL-L TIN	Flutes	Rekord B-VA NT	Flutes	Rekord B-VA NT	Flutes	Rekord B-VA NT	Flutes
No. 4	40	1 7/8	1.88	0.433	0.709	0.141	0.110	0.0890	.5003	●	2	●	2				
No. 5	40	1 15/16	1.94	0.433	0.709	0.141	0.110	0.1015	.5004	●	3	●	3				
No. 6	32	2	2.00	0.472	0.748	0.141	0.110	0.1110	.5005	●	3	●	3				
No. 8	32	2 1/8	2.13	0.512	0.827	0.168	0.131	0.1360	.5006	●	3	●	3				
No. 10	24	2 3/8	2.38	0.591	0.945	0.194	0.152	0.1520	.5007	●	3	●	3				
1/4	20	2 1/2	2.50	0.669	1.142	0.255	0.191	0.2040	.5009	●	3	●	3	●	3	1) ● (+.0035) 3	
5/16	18	2 23/32	2.72	0.787	1.299	0.318	0.238	0.2610	.5010	●	3	●	3	●	3	● (+.0050) 3	
3/8	16	2 15/16	2.94	0.866	1.378	0.381	0.286	0.3160	.5011	●	3	●	3	●	3	● (+.0050) 3	
7/16	14	3 5/32	3.16	0.866	—	0.323	0.242	0.3680	.5012	●	3	●	3	●	3	● (+.0050) 3	
1/2	13	3 3/8	3.38	0.984	—	0.367	0.275	0.4219	.5013	●	3	●	3	●	3	● (+.0050) 3	
9/16	12	3 19/32	3.59	1.024	—	0.429	0.322	0.4844	.5014	●	3	●	3				
5/8	11	3 13/16	3.81	1.063	—	0.480	0.360	0.5313	.5015	●	3	●	3	●	3	● (+.0050) 3	
3/4	10	4 1/4	4.25	1.181	—	0.590	0.442	0.6563	.5016	●	3	●	3				

1) Tool Identification = AU203043

DIN Length • ANSI Shank



All ANSI Length • ANSI Shank taps are available in the popular DIN Length • ANSI Shank style.

The DIN Length • ANSI Shank configuration allows for added reach capabilities and greater chip clearance.

VA Stainless Steel Materials						TI Titanium						Tool Identification				
Enorm VA NE2		Enorm VA NE2		Enorm VA NE2		Rekord C-TI NT2		Rekord C-TI NT2		Rekord D-TI NT2		Rekord D-TI NT2		Dimens. ID	Nominal Size ø d ₁	T.P.I.
●	2					●	2			●	2					
●	3					●	2			●	2			.5004	No. 5	40
●	3					●	3			●	3			.5005	No. 6	32
●	3					●	3			●	3			.5006	No. 8	32
●	3			2) ● (+.0035)	3	●	3			●	3			.5007	No. 10	24
●	3	●	3	● (+.0050)	3	●	3	●	3	●	3	●	3	.5009	1/4	20
●	3	●	3	● (+.0050)	3	●	3	●	3	●	3	●	3	.5010	5/16	18
●	3	●	3	● (+.0050)	3	●	3	●	3	●	3	●	3	.5011	3/8	16
●	3	●	3	● (+.0050)	3	●	3	●	3	●	3	●	3	.5012	7/16	14
●	3	●	3	● (+.0050)	3	●	3	●	3	●	3	●	3	.5013	1/2	13
●	3					●	3			●	3			.5014	9/16	12
●	3			● (+.0050)	3	●	3	●	3	●	3	●	3	.5015	5/8	11
●	3					●	3	●	3	●	3	●	3	.5016	3/4	10

2) Tool Identification = AU503243

Product Finder

V_c

UNC

UNF

UNEF

UN-8

...

MF

NPSM/NPSC

NPSF

Rp (BSPP)

G

NPT

NTF

Rc (BSPT)

STI

SELF-LOCK

Accessories

Tech. Info



- Product Finder
- V_c
- UNC
- UNF
- UNEF
- UN-8
- M
- MF
- NPSM/NPSC
- NPSF
- Rp (BSPP)
- G
- NPT
- NPTF
- Rc (BSPT)
- STI
- SELF-LOCK
- Accessories
- Tech. Info

ANSI Length • ANSI Shank

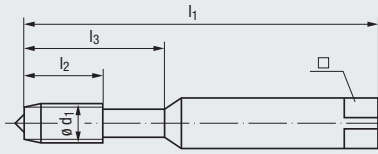

Reinforced Shank
(No.4 - 3/8)

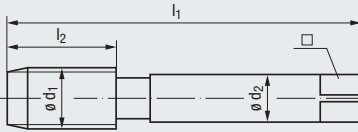

Reduced Shank
(7/16 - 3/4)



H
Materials of High
Tensile Strength

UNC

**Unified Coarse Thread
ASME B1.1**

Class of Fit
Coating
Cutting Material
Technical Characteristics

2BX	2BX
NT	TICN
HSS Extra	HSS Extra
C / 2-3	C / 2-3
E / O / P	E / O / P

Thread Depth
and Hole Shape

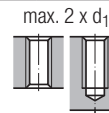

Applications – Material

P 1.1-3.1	P 1.1-4.1
K 1.1-4.2	K 1.1-4.2
N 2.4-7	N 2.4-7
N 4.1, 5.1	N 4.1, 5.1

Nominal Size ø d ₁	T.P.I.	inch				ø d ₂	□	Tool Identification	AU100501		AU109101		
		l ₁	l ₂	l ₃	□				Rekord A-H NT	Flutes	Rekord A-H TICN	Flutes	
No. 4	40	1 7/8	1.88	0.433	0.709	0.141	0.110	0.0890	.5003	●	3	●	3
No. 5	40	1 15/16	1.94	0.433	0.709	0.141	0.110	0.1015	.5004	●	3	●	3
No. 6	32	2	2.00	0.472	0.748	0.141	0.110	0.1110	.5005	●	3	●	3
No. 8	32	2 1/8	2.13	0.512	0.827	0.168	0.131	0.1360	.5006	●	3	●	3
No. 10	24	2 3/8	2.38	0.591	0.945	0.194	0.152	0.1520	.5007	●	3	●	3
1/4	20	2 1/2	2.50	0.669	1.142	0.255	0.191	0.2040	.5009	●	3	●	3
5/16	18	2 23/32	2.72	0.787	1.299	0.318	0.238	0.2610	.5010	●	3	●	3
3/8	16	2 15/16	2.94	0.866	1.378	0.381	0.286	0.3160	.5011	●	3	●	3
7/16	14	3 5/32	3.16	0.866	—	0.323	0.242	0.3680	.5012	●	3	●	3
1/2	13	3 3/8	3.38	0.984	—	0.367	0.275	0.4219	.5013	●	3	●	3
9/16	12	3 19/32	3.59	1.024	—	0.429	0.322	0.4844	.5014	●	3	●	3
5/8	11	3 13/16	3.81	1.063	—	0.480	0.360	0.5313	.5015	●	3	●	3
3/4	10	4 1/4	4.25	1.181	—	0.590	0.442	0.6563	.5016	●	4	●	4

ANSI Length · ANSI Shank

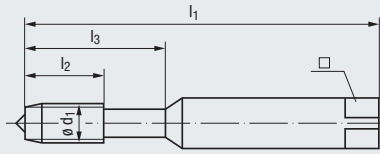

Reinforced Shank
(No.4 - 3/8)

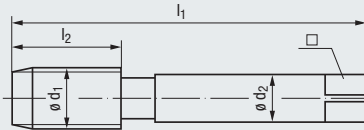

Reduced Shank
(7/16 - 3/4)

UNC



Unified Coarse Thread
ASME B1.1

Class of Fit: 2B, 3B
Coating: TIN
Cutting Material: HSS Extra
Technical Characteristics: R45, E / 1.5-2, E / O / P

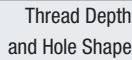

Thread Depth and Hole Shape

Applications – Material

P 1.1-4.1	P 1.1-4.1	P 1.1-4.1	P 1.1-4.1
M 1.1-2.1	M 1.1-3.1	M 1.1-2.1	M 1.1-3.1
N 2.1	N 1.4-6	N 2.1	N 1.4-6
	N 2.1-2, 2.4-5		N 2.1-2, 2.4-5
	S 1.1		S 1.1



max. 3 x d₁



Tool Identification

AU513500		AU513700		AU513510		AU513710	
Enorm Z/E	Flutes	Enorm Z/E TIN	Flutes	Enorm Z/E	Flutes	Enorm Z/E TIN	Flutes

Nominal Size ø d ₁	T.P.I.	inch						□	Dimens. ID	AU513500		AU513700		AU513510		AU513710	
		l ₁	l ₂	l ₃	ø d ₂	Enorm Z/E	Flutes			Enorm Z/E TIN	Flutes	Enorm Z/E	Flutes	Enorm Z/E TIN	Flutes		
No. 4	40	1 7/8	1.88	0.236	0.709	0.141	0.110	0.0890	.5003	●	2	●	2				
No. 5	40	1 15/16	1.94	0.276	0.709	0.141	0.110	0.1015	.5004	●	3	●	3				
No. 6	32	2	2.00	0.276	0.748	0.141	0.110	0.1110	.5005	●	3	●	3				
No. 8	32	2 1/8	2.13	0.315	0.827	0.168	0.131	0.1360	.5006	●	3	●	3				
No. 10	24	2 3/8	2.38	0.354	0.945	0.194	0.152	0.1520	.5007	●	3	●	3				
1/4	20	2 1/2	2.50	0.512	1.142	0.255	0.191	0.2040	.5009	●	3	●	3	●	3	●	3
5/16	18	2 23/32	2.72	0.551	1.299	0.318	0.238	0.2610	.5010	●	3	●	3	●	3	●	3
3/8	16	2 15/16	2.94	0.630	1.378	0.381	0.286	0.3160	.5011	●	3	●	3	●	3	●	3
7/16	14	3 5/32	3.16	0.709	—	0.323	0.242	0.3680	.5012	●	4	●	4	●	4	●	4
1/2	13	3 3/8	3.38	0.787	—	0.367	0.275	0.4219	.5013	●	4	●	4	●	4	●	4
9/16	12	3 19/32	3.59	0.787	—	0.429	0.322	0.4844	.5014	●	4	●	4				
5/8	11	3 13/16	3.81	0.866	—	0.480	0.360	0.5313	.5015	●	4	●	4				
3/4	10	4 1/4	4.25	0.984	—	0.590	0.442	0.6563	.5016	●	4	●	4				

DIN Length · ANSI Shank



All ANSI Length · ANSI Shank taps are available in the popular DIN Length · ANSI Shank style.

The DIN Length · ANSI Shank configuration allows for added reach capabilities and greater chip clearance.

● = In stock
★ = Allow 7 days for delivery

- Product Finder
- V_c
- UNC
- UNF
- UNEF
- UN-8
- MF
- NPSM/NPSC
- NPSF
- Rp (BSPP)
- G
- NPT
- NPTF
- Rc (BSPT)
- STI
- SELF-LOCK
- Accessories
- Tech. Info



- Product Finder
- V_c
- UNC
- UNF
- UNEF
- UN-8
- M
- MF
- NPSM/NPSC
- NPSF
- Rp (BSPP)
- G
- NPT
- NPTF
- Rc (BSPT)
- STI
- SELF-LOCK
- Accessories
- Tech. Info

DIN Length - ANSI Shank

Overall length acc. to DIN 371, DIN 374

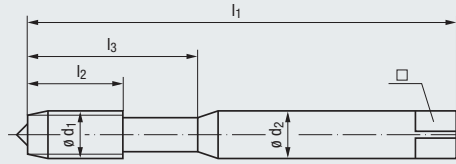

Reinforced Shank
(No.0 - 3/8)

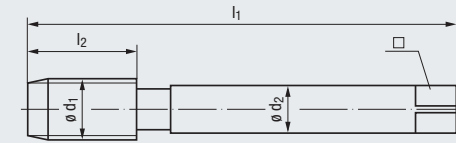

Reduced Shank
(7/16 - 1 1/2)



UNF
Unified Fine Thread
ASME B1.1

Class of Fit
Coating
Cutting Material
Technical Characteristics

Thread Depth and Hole Shape

Applications - Material

STEEL
Steel
Materials



2B	2B	2B	2B	3B
TIN	TIN	TICN		
HSS Extra	HSS Extra	HSS Extra	HSS Extra	HSS Extra
R15	R15	R15	R35	R35
B / 4-5	C / 2-3	C / 2-3	C / 2-3	C / 2-3
E / 0	E / 0	E / 0	E / 0	E / 0

max. 3 x d ₁	max. 2 x d ₁	max. 2.5 x d ₁		

P 1.1-4.1	P 1.1-4.1	P 1.1-4.1	P 1.1-3.1	P 1.1-3.1
K 2.1	K 1.1-4.2	K 1.1-4.2	N 2.2	N 2.2
N 2.2, 2.4-5	N 1.4-5, 2.4-5	N 1.4-5, 2.4-5		

Reinforced Shank

Nominal Size ø d ₁	T.P.I.	inch					□	Tool Identification	BU208400		BU451400		BU979000		BU501000		BU501010	
		l ₁	l ₂	l ₃	ø d ₂	□			Rekord 1B-STEEL-L TIN	Flutes	Rekord 1D-STEEL TIN	Flutes	Rekord 1D-STEEL IKZ-TICN	Flutes	Enorm 1-STEEL	Flutes	Enorm 1-STEEL	Flutes
No. 0	80	1.626	0.236	0.433	0.141	0.110	0.0480	.5033	●	2	●	2			●	2		
No. 1	72	1.772	0.276	0.472	0.141	0.110	0.0595	.5034	●	2	●	2			●	2		
No. 2	64	1.772	0.276	0.472	0.141	0.110	0.0730	.5035	●	2	●	2			●	2		
No. 3	56	1.969	0.354	0.551	0.141	0.110	0.0827	.5036	●	2	●	2			●	2		
No. 4	48	2.205	0.433	0.709	0.141	0.110	0.0945	.5037	●	2	●	2			●	2	●	2
No. 5	44	2.205	0.433	0.709	0.141	0.110	0.1063	.5038	●	3	●	2			●	3	●	3
No. 6	40	2.205	0.472	0.787	0.141	0.110	0.1181	.5039	●	3	●	3			●	3	●	3
No. 8	36	2.480	0.512	0.827	0.168	0.131	0.1378	.5040	●	3	●	3			●	3	●	3
No. 10	32	2.756	0.512	0.984	0.194	0.152	0.1614	.5041	●	3	●	3	●	3	●	3	●	3
No. 12	28	3.150	0.630	1.142	0.220	0.165	0.1820	.5042	●	3	●	3			●	3	●	3
1/4	28	3.150	0.669	1.181	0.255	0.191	0.2165	.5043	●	3	●	3	●	3	●	3	●	3
5/16	24	3.543	0.669	1.260	0.318	0.238	0.2717	.5044	●	3	●	3	●	3	●	3	●	3
3/8	24	3.937	0.709	1.535	0.381	0.286	0.3346	.5045	●	4	●	3	●	3	●	3	●	3

Reduced Shank

Nominal Size ø d ₁	T.P.I.	inch					□	Tool Identification	CU208400		CU451400		CU979000		CU501000		CU501010	
		l ₁	l ₂	l ₃	ø d ₂	□			Rekord 2B-STEEL-L TIN	Flutes	Rekord 2D-STEEL TIN	Flutes	Rekord 2D-STEEL IKZ-TICN	Flutes	Enorm 2-STEEL	Flutes	Enorm 2-STEEL	Flutes
7/16	20	3.937	0.866	—	0.323	0.242	0.3898	.5046	●	3	●	3	●	3	●	3	●	3
1/2	20	3.937	0.866	—	0.367	0.275	0.4528	.5047	●	3	●	3	●	3	●	4	●	4
9/16	18	3.937	0.866	—	0.429	0.322	0.5118	.5048	●	3	●	3	●	3	●	4	●	4
5/8	18	3.937	0.866	—	0.480	0.360	0.5709	.5049	●	3	●	3	●	3	●	4	●	4
3/4	16	4.331	0.984	—	0.590	0.442	0.6890	.5050	●	4	●	4	●	4	●	4	●	4
7/8	14	4.921	1.024	—	0.697	0.523	0.8071	.5051	●	4	●	4	●	4	●	4	●	4
1	12	5.512	1.102	—	0.800	0.600	0.9219	.5052	●	4	●	4	●	4	●	4	●	4
1 1/8	12	5.906	1.181	—	0.896	0.672	1.0433	.5053	●	4			●	4	●	4	●	4
1 1/4	12	5.906	1.181	—	1.021	0.766	1.1719	.5054	●	4			●	5	●	5	●	5
1 3/8	12	6.693	1.299	—	1.108	0.831	1.2992	.5055	●	5			●	5	●	5	●	5
1 1/2	12	6.693	1.299	—	1.233	0.925	1.4173	.5056	●	5			●	6	●	6	●	6

VA
Stainless Steel
Materials



2B	2B	3B	Oversize	2B	2B	3B	3B
GLT-1	TICN	GLT-1	GLT-1	NE2	GLT-1	NE2	GLT-1
HSS Extra	HSS Extra	HSS Extra	HSS Extra	HSS Extra	HSS Extra	HSS Extra	HSS Extra
B / 4-5	B / 4-5	B / 4-5	B / 4-5	R35	R35	R35	R35
E / O / P	E / O / P	E / O / P	E / O / P	C / 2-3	C / 2-3	C / 2-3	C / 2-3
E / O / P	E / O / P	E / O / P	E / O / P	E / O / P	E / O / P	E / O / P	E / O / P

Class of Fit
Coating
Cutting Material
Technical Characteristics

max. 3 x d₁



max. 2.5 x d₁



Thread Depth and Hole Shape

P 1.1-4.1	P 1.1-4.1	P 1.1-4.1	P 1.1-4.1	P 1.1-3.1	P 1.1-4.1	P 1.1-3.1	P 1.1-4.1
M 1.1-3.1	M 1.1-3.1	M 1.1-3.1	M 1.1-3.1	M 1.1-2.1	M 1.1-3.1	M 1.1-2.1	M 1.1-3.1
K 2.1	K 2.1	K 2.1	K 2.1	K 2.1	K 2.1	K 2.1	K 2.1
N 2.2	N 2.2, 2.5-6	N 2.2	N 2.2				

Applications – Material

BU20C300		BU089300		BU20C310		BU20C344		BU503200		BU50C300		BU503210		BU50C310		Tool Identification		
Rekord 1B-VA GLT-1	Flutes	Rekord 1B-VA-1KZN TICN	Flutes	Rekord 1B-VA GLT-1	Flutes	Rekord 1B-VA GLT-1	Flutes	Enorm 1-VA NE2	Flutes	Enorm 1-VA GLT-1	Flutes	Enorm 1-VA NE2	Flutes	Enorm 1-VA GLT-1	Flutes	Dimens. ID	Nominal Size ø d ₁	T.P.I.
●	2			●	2			●	2	●	2	●	2	●	2	.5033	No. 0	80
●	2			●	2			●	2	●	2	●	2	●	2	.5034	No. 1	72
●	2			●	2			●	2	●	2	●	2	●	2	.5035	No. 2	64
●	2			●	2			●	2	●	2	●	2	●	2	.5036	No. 3	56
●	2			●	2			●	2	●	2	●	2	●	2	.5037	No. 4	48
●	3			●	3			●	3	●	3	●	3	●	3	.5038	No. 5	44
●	3			●	3			●	3	●	3	●	3	●	3	.5039	No. 6	40
●	3			●	3			●	3	●	3	●	3	●	3	.5040	No. 8	36
●	3	●	3	●	3			●	3	●	3	●	3	●	3	.5041	No. 10	32
●	3			●	3			●	3	●	3	●	3	●	3	.5042	No. 12	28
●	3	●	3	●	3			●	3	●	3	●	3	●	3	.5043	1/4	28
●	3	●	3	●	3			●	3	●	3	●	3	●	3	.5044	5/16	24
●	4	●	4	●	4			●	3	●	3	●	3	●	3	.5045	3/8	24

CU20C300		CU089300		CU20C310		CU20C344		CU503200		CU50C300		CU503210		CU50C310		Tool Identification		
Rekord 2B-VA GLT-1	Flutes	Rekord 2B-VA-1KZN TICN	Flutes	Rekord 2B-VA GLT-1	Flutes	Rekord 2B-VA GLT-1	Flutes	Enorm 2-VA NE2	Flutes	Enorm 2-VA GLT-1	Flutes	Enorm 2-VA NE2	Flutes	Enorm 2-VA GLT-1	Flutes	Dimens. ID	Nominal Size ø d ₁	T.P.I.
●	3	●	3	●	3	● (+.0050)	3	●	3	●	3	●	3	●	3	.5046	7/16	20
●	3	●	3	●	3	● (+.0050)	3	●	4	●	4	●	4	●	4	.5047	1/2	20
●	3			●	3			●	4	●	4	●	4	●	4	.5048	9/16	18
●	3			●	3	● (+.0050)	3	●	4	●	4	●	4	●	4	.5049	5/8	18
●	4			●	4			●	4	●	4	●	4	●	4	.5050	3/4	16
●	4			●	4			●	4	●	4	●	4	●	4	.5051	7/8	14
●	4			●	4			●	4	●	4	●	4	●	4	.5052	1	12
●	4			●	4			●	4	●	4	●	4	●	4	.5053	1 1/8	12
●	4			●	4			●	5	●	5	●	5	●	5	.5054	1 1/4	12
●	5			●	5			●	5	●	5	●	5	●	5	.5055	1 3/8	12
●	5			●	5			●	6	●	6	●	6	●	6	.5056	1 1/2	12

● = In stock
★ = Allow 7 days for delivery

1) Tool Identification = BU20C343

Product Finder

V_c

UNC

UNF

UNEF

UN-8

MF

NPSM/NPSC

NPSF

Rp (BSP)

G

NPT

NPTF

Rc (BSPT)

STI

SELF-LOCK

Accessories

Tech. Info



- Product Finder
- V_c
- UNC
- UNF
- UNEF
- UN-8
- M
- MF
- NPSM/NPSC
- NPSF
- Rp (BSPP)
- G
- NPT
- NPTF
- Rc (BSPT)
- STI
- SELF-LOCK
- Accessories
- Tech. Info

DIN Length - ANSI Shank

Overall length acc. to DIN 371, DIN 374

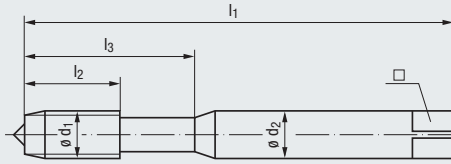

Reinforced Shank
(No.0 - 3/8)

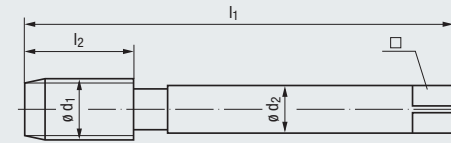

Reduced Shank
(7/16 - 1 1/2)

UNF

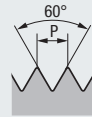

Unified Fine Thread
ASME B1.1

Class of Fit
Coating
Cutting Material
Technical Characteristics



Thread Depth and Hole Shape

Applications - Material

VA
Stainless Steel
Materials



new

Enlarge
GLT-1
HSS Extra
R35
C / 2-3
E / O / P

max. 2.5 x d₁



P 1.1-4.1
M 1.1-3.1
K 2.1

AL
Aluminum
Wrought Alloys



new

2B
GLT-8
HSS Extra
B / approx. 3
E / O

max. 3 x d₁



new

2B
GLT-8
HSS Extra
R45
C / 2-3
E / O

max. 2.5 x d₁



new

3B
GLT-8
HSS Extra
R45
C / 2-3
E / O

max. 2.5 x d₁



N 1.1-4

Reinforced Shank

Nominal Size ø d ₁	T.P.I.	inch					□	Tool Identification		BU50C344		BU20S800		BU50S800		BU50S810	
		l ₁	l ₂	l ₃	ø d ₂	□		Dimens. ID	Enorm 1-VA GLT-1	Flutes	Rekord 1B-AL GLT-8	Flutes	Enorm 1-AL GLT-8	Flutes	Enorm 1-AL GLT-8	Flutes	
No. 0	80	1.626	0.236	0.433	0.141	0.110	0.0480	.5033			●	2	●	2			
No. 1	72	1.772	0.276	0.472	0.141	0.110	0.0595	.5034			●	2	●	2			
No. 2	64	1.772	0.276	0.472	0.141	0.110	0.0730	.5035			●	2	●	2			
No. 3	56	1.969	0.354	0.551	0.141	0.110	0.0827	.5036			●	2	●	2			
No. 4	48	2.205	0.433	0.709	0.141	0.110	0.0945	.5037			●	2	●	2			
No. 5	44	2.205	0.433	0.709	0.141	0.110	0.1063	.5038			●	2	●	2			
No. 6	40	2.205	0.472	0.787	0.141	0.110	0.1181	.5039	1) ● (+.0035)	3	●	2	●	2			
No. 8	36	2.480	0.512	0.827	0.168	0.131	0.1378	.5040	1) ● (+.0035)	3	●	2	●	2			
No. 10	32	2.756	0.512	0.984	0.194	0.152	0.1614	.5041	1) ● (+.0035)	3	●	2	●	2	●	2	
No. 12	28	3.150	0.630	1.142	0.220	0.165	0.1820	.5042			●	2	●	2			
1/4	28	3.150	0.669	1.181	0.255	0.191	0.2165	.5043	● (+.0050)	3	●	2	●	2	●	2	
5/16	24	3.543	0.669	1.260	0.318	0.238	0.2717	.5044	● (+.0050)	3	●	2	●	2	●	2	
3/8	24	3.937	0.709	1.535	0.381	0.286	0.3346	.5045	● (+.0050)	3	●	3	●	2	●	2	

Reduced Shank

Nominal Size ø d ₁	T.P.I.	inch					□	Tool Identification		CU50C344		CU20S800		CU50S800		CU50S810	
		l ₁	l ₂	l ₃	ø d ₂	□		Dimens. ID	Enorm 2-VA GLT-1	Flutes	Rekord 2B-AL GLT-8	Flutes	Enorm 2-AL GLT-8	Flutes	Enorm 2-AL GLT-8	Flutes	
7/16	20	3.937	0.866	—	0.323	0.242	0.3898	.5046	● (+.0050)	3	●	3	●	3	●	3	
1/2	20	3.937	0.866	—	0.367	0.275	0.4528	.5047	● (+.0050)	4	●	3	●	4	●	4	
9/16	18	3.937	0.866	—	0.429	0.322	0.5118	.5048			●	3	●	4	●	4	
5/8	18	3.937	0.866	—	0.480	0.360	0.5709	.5049	● (+.0050)	4	●	3	●	4	●	4	
3/4	16	4.331	0.984	—	0.590	0.442	0.6890	.5050			●	4	●	4	●	4	
7/8	14	4.921	1.024	—	0.697	0.523	0.8071	.5051									
1	12	5.512	1.102	—	0.800	0.600	0.9219	.5052									
1 1/8	12	5.906	1.181	—	0.896	0.672	1.0433	.5053									
1 1/4	12	5.906	1.181	—	1.021	0.766	1.1719	.5054									
1 3/8	12	6.693	1.299	—	1.108	0.831	1.2992	.5055									
1 1/2	12	6.693	1.299	—	1.233	0.925	1.4173	.5056									

AERO Nickel Alloys		Ti Titanium														
<p>3BX</p> <p>NT</p> <p>HSS Extra</p> <p>B / approx. 3</p> <p>O / P</p>		<p>2BX</p> <p>NT2</p> <p>HSS Extra</p> <p>L15</p> <p>D / 4-5</p> <p>E / O / P</p>		<p>3BX</p> <p>NT2</p> <p>HSS Extra</p> <p>L15</p> <p>D / 4-5</p> <p>E / O / P</p>		<p>3BX</p> <p>TICN</p> <p>HSS Extra</p> <p>L15</p> <p>D / 4-5</p> <p>E / O / P</p>		<p>2BX</p> <p>NT2</p> <p>HSS Extra</p> <p>R15</p> <p>C / 2-3</p> <p>E / O / P</p>		<p>3BX</p> <p>NT2</p> <p>HSS Extra</p> <p>R15</p> <p>C / 2-3</p> <p>E / O / P</p>		<p>3BX</p> <p>TICN</p> <p>HSS Extra</p> <p>R15</p> <p>C / 2-3</p> <p>E / O / P</p>		<p>Class of Fit</p> <p>Coating</p> <p>Cutting Material</p> <p>Technical Characteristics</p>		
<p>max. 3 x d₁</p>		<p>max. 3 x d₁</p>		<p>max. 3 x d₁</p>		<p>max. 2 x d₁</p>						<p>Thread Depth and Hole Shape</p>				
<p>M 4.1</p> <p>N 2.8</p> <p>S 2.3, 2.5-6</p>		<p>P 4.1-5.1</p> <p>M 3.1-4.1</p> <p>N 2.4-5, 2.7</p> <p>S 1.1-2.2, 2.4</p>		<p>P 4.1-5.1</p> <p>M 3.1-4.1</p> <p>N 2.4-5, 2.7</p> <p>S 1.1-2.2, 2.4</p>		<p>P 4.1-5.1</p> <p>M 3.1-4.1</p> <p>N 2.4-5, 2.7</p> <p>S 1.1-2.2, 2.4</p>		<p>P 4.1-5.1</p> <p>M 3.1-4.1</p> <p>N 2.4-5, 2.7</p> <p>S 1.1-2.2, 2.4</p>		<p>P 4.1-5.1</p> <p>M 3.1-4.1</p> <p>N 2.4-5, 2.7</p> <p>S 1.1-2.2, 2.4</p>		<p>Applications – Material</p>				
BU206511		BU306001		BU306011		BU309611		BU456001		BU456011		BU459611		Tool Identification		
Rekord 1B-AERO NT	Flutes	Rekord 1C-TI NT2	Flutes	Rekord 1C-TI NT2	Flutes	Rekord 1C-TI TICN	Flutes	Rekord 1D-TI NT2	Flutes	Rekord 1D-TI NT2	Flutes	Rekord 1D-TI TICN	Flutes	Dimens. ID	Nominal Size ø d ₁	T.P.I.
●	3	●	2	●	2			●	2	●	2			.5033	No. 0	80
		●	2	●	2			●	2	●	2			.5034	No. 1	72
		●	2	●	2			●	2	●	2			.5035	No. 2	64
		●	2	●	2			●	2	●	2			.5036	No. 3	56
		●	2	●	2			●	2	●	2			.5037	No. 4	48
		●	2	●	2			●	2	●	2			.5038	No. 5	44
●	3	●	3	●	3			●	3	●	3			.5039	No. 6	40
●	3	●	3	●	3	●	3	●	3	●	3	●	3	.5040	No. 8	36
●	3	●	3	●	3	●	3	●	3	●	3	●	3	.5041	No. 10	32
●	3	●	3	●	3	●	3	●	3	●	3	●	3	.5042	No. 12	28
●	3	●	3	●	3	●	3	●	3	●	3	●	3	.5043	1/4	28
●	3	●	3	●	3	●	3	●	3	●	3	●	3	.5044	5/16	24
●	4	●	3	●	3	●	3	●	3	●	3	●	3	.5045	3/8	24
CU206511		CU306001		CU306011		CU309611		CU456001		CU456011		CU459611		Tool Identification		
Rekord 2B-AERO NT	Flutes	Rekord 2C-TI NT2	Flutes	Rekord 2C-TI NT2	Flutes	Rekord 2C-TI TICN	Flutes	Rekord 2D-TI NT2	Flutes	Rekord 2D-TI NT2	Flutes	Rekord 2D-TI TICN	Flutes	Dimens. ID	Nominal Size ø d ₁	T.P.I.
●	3	●	3	●	3	●	3	●	3	●	3	●	3	.5046	7/16	20
●	3	●	3	●	3	●	3	●	3	●	3	●	3	.5047	1/2	20
		●	3	●	3	●	3	●	3	●	3	●	3	.5048	9/16	18
●	3	●	3	●	3	●	3	●	3	●	3	●	3	.5049	5/8	18
●	4	●	4	●	4	●	4	●	4	●	4	●	4	.5050	3/4	16
		●	4	●	4	●	4	●	4	●	4	●	4	.5051	7/8	14
				●	4	●	4	●	4	●	4	●	4	.5052	1	12
								●	4	●	4	●	4	.5053	1 1/8	12
								●	4	●	4	●	4	.5054	1 1/4	12
								●	5	●	5	●	5	.5055	1 3/8	12
								●	5	●	5	●	5	.5056	1 1/2	12

Product Finder

- V_c
- UNC
- UNF
- UNEF
- UN-8
- MF
- NPSM/NPSC
- NPSF
- Rp (BSPP)
- G
- NPT
- NPTF
- Rc (BSPT)
- STI
- SELF-LOCK
- Accessories
- Tech. Info



● = In stock
★ = Allow 7 days for delivery

- Product Finder
- V_c
- UNC
- UNF
- UNEF
- UN-8
- M
- MF
- NPSM/NPSC
- NPSF
- Rp (BSPP)
- G
- NPT
- NPTF
- Rc (BSPT)
- STI
- SELF-LOCK
- Accessories
- Tech. Info

DIN Length - ANSI Shank

Overall length acc. to DIN 371, DIN 374

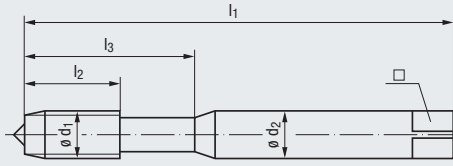

Reinforced Shank
(No.0 - 3/8)

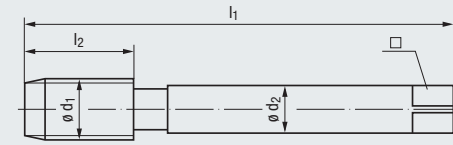

Reduced Shank
(7/16 - 1 1/2)

NI
Nickel
Alloys



H
Materials of High
Tensile Strength



UNF

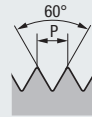

Unified Fine Thread
ASME B1.1

Class of Fit
Coating
Cutting Material
Technical Characteristics



Thread Depth
and Hole Shape

Applications - Material









3BX	3BX	2BX	2BX
TICN	TICN	NT	TICN
HSSE-PM	HSSE-PM	HSS Extra	HSS Extra
L08	R10	C / 2-3	C / 2-3
D / 4-5	C / 2-3	E / O / P	E / O / P
O / P	O / P		
max. 3 x d ₁	max. 2 x d ₁	max. 2 x d ₁	
M 4.1	M 4.1	P 1.1-3.1	P 1.1-4.1
N 2.8	N 2.8	K 1.1-4.2	K 1.1-4.2
S 1.2-3	S 1.2-3	N 2.4-7	N 2.4-7
S 2.3, 2.5-6	S 2.3, 2.5-6	N 4.1, 5.1	N 4.1, 5.1

Reinforced Shank

Nominal Size ø d ₁	T.P.I.	l ₁	l ₂	inch		ø d ₂	□	Tool Identification	BU30J411		BU35J411		BU100501		BU109101	
				Rekord 1C-NI-PM TICN	Flutes				Rekord 1DF-NI-PM TICN	Flutes	Rekord 1A-H NT	Flutes	Rekord 1A-H TICN	Flutes		
No. 0	80	1.626	0.236	0.433	0.141	0.110	0.0480	.5033					●	2	●	2
No. 1	72	1.772	0.276	0.472	0.141	0.110	0.0595	.5034					●	2	●	2
No. 2	64	1.772	0.276	0.472	0.141	0.110	0.0730	.5035					●	3	●	3
No. 3	56	1.969	0.354	0.551	0.141	0.110	0.0827	.5036					●	3	●	3
No. 4	48	2.205	0.433	0.709	0.141	0.110	0.0945	.5037					●	3	●	3
No. 5	44	2.205	0.433	0.709	0.141	0.110	0.1063	.5038					●	3	●	3
No. 6	40	2.205	0.472	0.787	0.141	0.110	0.1181	.5039					●	3	●	3
No. 8	36	2.480	0.512	0.827	0.168	0.131	0.1378	.5040					●	3	●	3
No. 10	32	2.756	0.512	0.984	0.194	0.152	0.1614	.5041	●	3	●	3	●	3	●	3
No. 12	28	3.150	0.630	1.142	0.220	0.165	0.1820	.5042	●	3	●	3	●	3	●	3
1/4	28	3.150	0.669	1.181	0.255	0.191	0.2165 ²⁾	.5043	●	3	●	3	●	3	●	3
5/16	24	3.543	0.669	1.260	0.318	0.238	0.2717 ²⁾	.5044	●	3	●	3	●	3	●	3
3/8	24	3.937	0.709	1.535	0.381	0.286	0.3346 ²⁾	.5045	●	3	●	3	●	4	●	4

Reduced Shank

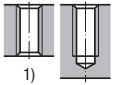
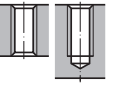
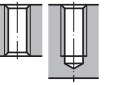
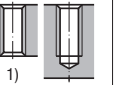
Nominal Size ø d ₁	T.P.I.	l ₁	l ₂	inch		ø d ₂	□	Tool Identification	CU30J411		CU35J411		CU100501		CU109101	
				Rekord 2C-NI-PM TICN	Flutes				Rekord 2DF-NI-PM TICN	Flutes	Rekord 2A-H NT	Flutes	Rekord 2A-H TICN	Flutes		
7/16	20	3.937	0.866	—	0.323	0.242	0.3898 ²⁾	.5046	●	3	●	3	●	4	●	4
1/2	20	3.937	0.866	—	0.367	0.275	0.4528 ²⁾	.5047	●	3	●	3	●	4	●	4
9/16	18	3.937	0.866	—	0.429	0.322	0.5118	.5048	●	3	●	3	●	4	●	4
5/8	18	3.937	0.866	—	0.480	0.360	0.5709	.5049	●	3	●	3	●	4	●	4
3/4	16	4.331	0.984	—	0.590	0.442	0.6890	.5050	●	4	●	4	●	4	●	4
7/8	14	4.921	1.024	—	0.697	0.523	0.8071	.5051					●	4	●	4
1	12	5.512	1.102	—	0.800	0.600	0.9219	.5052					●	4	●	4
1 1/8	12	5.906	1.181	—	0.896	0.672	1.0433	.5053								
1 1/4	12	5.906	1.181	—	1.021	0.766	1.1719	.5054								
1 3/8	12	6.693	1.299	—	1.108	0.831	1.2992	.5055								
1 1/2	12	6.693	1.299	—	1.233	0.925	1.4173	.5056								

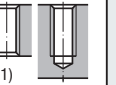
H Materials of High Tensile Strength		HCUT Hardened Steels		Z CNC-Controlled Machines						
										
2BX TICN HSS Extra		2BX TICN HSSE-PM		2BX TICN HSS Extra	2BX TICN HSS Extra	2BX TICN HSS Extra	2BX TICN HSS Extra	Class of Fit Coating Cutting Material Technical Characteristics		
C / 2-3 E / O		C / 2-3 O / P		C / 2-3 E / O / P	C / 2-3 E / O	C / 2-3 E / O	E / 1.5-2 E / O			
max. 2 x d ₁ 		max. 1.5 x d ₁ 		max. 2 x d ₁ 	max. 2 x d ₁ 	max. 2 x d ₁ 	max. 2 x d ₁ 	Thread Depth and Hole Shape		
P 1.1-4.1 K 1.1-4.2 N 2.4-7 N 4.1, 5.1		H 1.1-2		P 1.1-4.1 K 1.1-4.2 N 1.4-6, 2.4-7 N 4.1	P 1.1-4.1 K 1.1-4.2 N 1.4-6, 2.4-7 N 4.1	P 1.1-4.1 K 1.1-4.2 N 1.4-6, 2.4-7 N 4.1	P 1.1-4.1 K 1.1-4.2 N 1.4-6, 2.4-7 N 4.1	Applications – Material		
BU959101		BU10J901		BU109401	BU959401	BU219401	BU969401	Tool Identification		
Rekord 1A-H-IKZ TICN	Flutes	Rekord 1A-HCUT-PM TICN	Flutes	Rekord 1A-Z TICN	Rekord 1A-Z-IKZ TICN	Rekord 1A-Z-IKZN TICN	Rekord 1A-Z/E-IKZ TICN	Dimens. ID	Nominal Size ø d ₁	T.P.I.
●	3	●	4	●	●	●	●	.5033	No. 0	80
								.5034	No. 1	72
								.5035	No. 2	64
								.5036	No. 3	56
								.5037	No. 4	48
								.5038	No. 5	44
								.5039	No. 6	40
●	3			●	●	●	●	.5040	No. 8	36
								.5041	No. 10	32
●	3	●	5	●	●	●	●	.5042	No. 12	28
●	3	●	5	●	●	●	●	.5043	1/4	28
●	4	●	5	●	●	●	●	.5044	5/16	24
				●	●	●	●	.5045	3/8	24
CU959101		CU10J901		CU109401	CU959401	CU219401	CU969401	Tool Identification		
Rekord 2A-H-IKZ TICN	Flutes	Rekord 2A-HCUT-PM TICN	Flutes	Rekord 2A-Z TICN	Rekord 2A-Z-IKZ TICN	Rekord 2A-Z-IKZN TICN	Rekord 2A-Z/E-IKZ TICN	Dimens. ID	Nominal Size ø d ₁	T.P.I.
●	4	●	5	●	●	●	●	.5046	7/16	20
●	4	●	5	●	●	●	●	.5047	1/2	20
●	4			●	●	●	●	.5048	9/16	18
●	4			●	●	●	●	.5049	5/8	18
●	4			●	●	●	●	.5050	3/4	16
●	4							.5051	7/8	14
●	4							.5052	1	12
								.5053	1 1/8	12
								.5054	1 1/4	12
								.5055	1 3/8	12
								.5056	1 1/2	12

● = In stock
★ = Allow 7 days for delivery

1) Threading in through holes is possible only with external cooling/lubrication
2) Increase drill diameter for taps Rekord 1/2A-HCUT-PM-TICN by 0.004 in

Product Finder

- V_c
- UNC
- UNF
- UNEF
- UN-8
- MF
- NPSM/NPSC
- NPSF
- Rp (BSPP)
- G
- NPT
- NPTF
- Rc (BSPT)
- STI
- SELF-LOCK
- Accessories
- Tech. Info



- Product Finder
- V_c
- UNC
- UNF
- UNEF
- UN-8
- M
- MF
- NPSM/NPSC
- NPSF
- Rp (BSPP)
- G
- NPT
- NPTF
- Rc (BSPT)
- STI
- SELF-LOCK
- Accessories
- Tech. Info

DIN Length - ANSI Shank

Overall length acc. to DIN 371, DIN 374

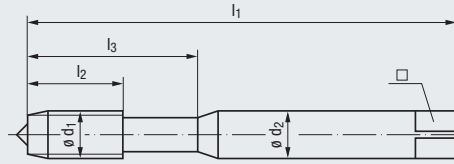

Reinforced Shank
(No.0 - 3/8)

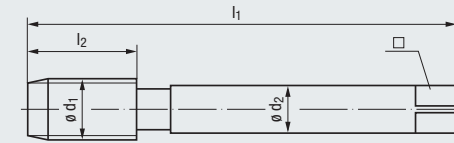

Reduced Shank
(7/16 - 1 1/2)

UNF

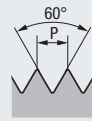

Unified Fine Thread
ASME B1.1

Class of Fit

Coating

Cutting Material

Technical Characteristics



Thread Depth
and Hole Shape

Applications - Material

Z
CNC-Controlled
Machines

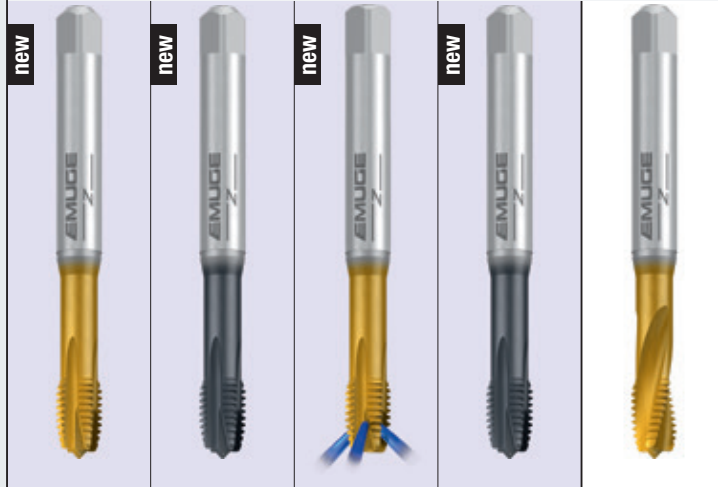

2BX	2BX	2BX	3BX	2BX
TIN-70	GLT-1	TIN-70	GLT-1	TIN
HSSE-PM	HSSE-PM	HSSE-PM	HSSE-PM	HSS Extra
B / 4-5	B / 4-5	B / 4-5	B / 4-5	R15
E / O / P	E / O / P	E / O	E / O / P	C / 2-3
				E / O / P

max. 3 x d₁



max. 2 x d₁



P 1.1-5.1	P 1.1-5.1	P 1.1-5.1	P 1.1-5.1	P 2.1-5.1
M 1.1-3.1	M 1.1-3.1	M 1.1-3.1	M 1.1-3.1	K 2.1-2
K 2.1	K 2.1	K 2.1	K 2.1	N 1.4-6, 2.4-5
N 1.4-2.2, 2.4-5	N 1.4-2.2, 2.4-5	N 1.4-2.2, 2.4-5	N 1.4-2.2, 2.4-5	
S 1.1	S 1.1	S 1.1	S 1.1	

Reinforced Shank

Nominal Size ø d ₁	T.P.I.	inch					□	Tool Identification		BU208F01		BU20A601		BU088F01		BU20A611		BU453701	
		l ₁	l ₂	l ₃	ø d ₂	□		Rekord 1B-Z-PM TIN-70	Flutes	Rekord 1B-Z-PM GLT-1	Flutes	Rekord 1B-Z-PM-TIN-70	Flutes	Rekord 1B-Z-PM GLT-1	Flutes	Rekord 1B-Z-PM GLT-1	Flutes	Rekord 1D-Z TIN	Flutes
No. 0	80	1.626	0.157	0.433	0.141	0.110	0.0480	.5033											
No. 1	72	1.772	0.157	0.472	0.141	0.110	0.0595	.5034											
No. 2	64	1.772	0.177	0.472	0.141	0.110	0.0730	.5035											
No. 3	56	1.969	0.197	0.551	0.141	0.110	0.0827	.5036											
No. 4	48	2.205	0.236	0.709	0.141	0.110	0.0945	.5037											
No. 5	44	2.205	0.276	0.709	0.141	0.110	0.1063	.5038											
No. 6	40	2.205	0.276	0.787	0.141	0.110	0.1181	.5039											
No. 8	36	2.480	0.315	0.827	0.168	0.131	0.1378	.5040											
No. 10	32	2.756	0.394	0.984	0.194	0.152	0.1614	.5041	●	3	●	3	●	3	●	3	●	3	3
No. 12	28	3.150	0.394	1.142	0.220	0.165	0.1820	.5042	●	3	●	3	●	3	●	3	●	3	3
1/4	28	3.150	0.394	1.181	0.255	0.191	0.2165	.5043	●	3	●	3	●	3	●	3	●	3	3
5/16	24	3.543	0.394	1.260	0.318	0.238	0.2717	.5044	●	4	●	4	●	4	●	4	●	4	3
3/8	24	3.937	0.394	1.535	0.381	0.286	0.3346	.5045	●	4	●	4	●	4	●	4	●	4	3

Reduced Shank

Nominal Size ø d ₁	T.P.I.	inch					□	Tool Identification		CU208F01		CU20A601		CU088F01		CU20A611		CU453701	
		l ₁	l ₂	l ₃	ø d ₂	□		Rekord 2B-Z-PM TIN-70	Flutes	Rekord 2B-Z-PM GLT-1	Flutes	Rekord 2B-Z-PM-TIN-70	Flutes	Rekord 2B-Z-PM GLT-1	Flutes	Rekord 2B-Z-PM GLT-1	Flutes	Rekord 2D-Z TIN	Flutes
7/16	20	3.937	0.512	—	0.323	0.242	0.3898	.5046	●	4	●	4	●	4	●	4	●	4	3
1/2	20	3.937	0.512	—	0.367	0.275	0.4528	.5047	●	4	●	4	●	4	●	4	●	4	3
9/16	18	3.937	0.591	—	0.429	0.322	0.5118	.5048	●	4	●	4	●	4	●	4	●	4	3
5/8	18	3.937	0.591	—	0.480	0.360	0.5709	.5049	●	4	●	4	●	4	●	4	●	4	3
3/4	16	4.331	0.669	—	0.590	0.442	0.6890	.5050	●	4	●	4	●	4	●	4	●	4	4
7/8	14	4.921	0.669	—	0.697	0.523	0.8071	.5051	●	4	●	4	●	4	●	4	●	4	4
1	12	5.512	0.787	—	0.800	0.600	0.9219	.5052											
1 1/8	12	5.906	0.866	—	0.896	0.672	1.0433	.5053											
1 1/4	12	5.906	0.866	—	1.021	0.766	1.1719	.5054											
1 3/8	12	6.693	0.945	—	1.108	0.831	1.2992	.5055											
1 1/2	12	6.693	0.984	—	1.233	0.925	1.4173	.5056											

Z
CNC-Controlled
Machines

2BX	2BX	2BX	2B	2B	2B	2B	2B
TIN	TIN	TIN	TIN	GLT-1	GLT-1	HSS Extra	TIN
HSS Extra	HSS Extra	HSS Extra	HSS Extra	HSS Extra	HSS Extra	HSS Extra	HSS Extra
R15	R15	R15	R45	R45	R45	R45	R45
C / 2-3	C / 2-3	C / 2-3	C / 2-3	C / 2-3	C / 2-3	E / 1.5-2	E / 1.5-2
E / O	E / O / P	E / O	E / O / P	E / O / P	E / O	E / O / P	E / O / P

- Product Finder
- V_c
- UNC
- UNF**
- UNEF
- UN-8
- MF
- NPSM/NPSC
- NPSF
- R_p (BSPP)
- G
- NPT
- NPTF
- Rc (BSPT)
- STI
- SELF-LOCK
- Accessories
- Tech. Info

max. 2 x d ₁ 			max. 3 x d ₁ 					Thread Depth and Hole Shape
-----------------------------	--	--	-----------------------------	--	--	--	--	------------------------------------

P 2.1-5.1	P 2.1-5.1	P 2.1-5.1	P 1.1-4.1	P 1.1-4.1	P 1.1-4.1	P 1.1-4.1	P 1.1-4.1
K 2.1-2	K 2.1-2	K 2.1-2	M 1.1-3.1	M 1.1-3.1	M 1.1-3.1	M 1.1-2.1	M 1.1-3.1
N 1.4-6, 2.4-5	N 1.4-6, 2.4-5	N 1.4-6, 2.4-5	N 1.4-6	N 1.4-6	N 1.4-6	N 2.1	N 1.4-6
			N 2.1-2, 2.4-5	N 2.1-2, 2.4-5	N 2.1-2, 2.4-5		N 2.1-2, 2.4-5
			S 1.1	S 1.1	S 1.1		S 1.1

Applications – Material

BU973701						BU523701						BU573701						BU50C400						BU94C400						BU513500						BU513700						Tool Identification		
Rekord 1D-Z- IKZ TIN		Flutes		Rekord 1D-Z- BF TIN		Flutes		Rekord 1D-Z- BF IKZ-TIN		Flutes		Enorm 1-Z GLT-1		Flutes		Enorm 1-Z- IKZ GLT-1		Flutes		Enorm 1-Z/E		Flutes		Enorm 1-Z/E TIN		Flutes		Dimens. ID	Nominal Size ø d ₁	T.P.I.														
●	3	●	3	●	3	●	3	●	3	●	3	●	3	●	3	●	3	●	3	●	3	●	3	●	3	●	3	.5033	No. 0	80														
●	3	●	3	●	3	●	3	●	3	●	3	●	3	●	3	●	3	●	3	●	3	●	3	●	3	●	3	.5034	No. 1	72														
●	3	●	3	●	3	●	3	●	3	●	3	●	3	●	3	●	3	●	3	●	3	●	3	●	3	●	3	.5035	No. 2	64														
●	3	●	3	●	3	●	3	●	3	●	3	●	3	●	3	●	3	●	3	●	3	●	3	●	3	●	3	.5036	No. 3	56														
●	3	●	3	●	3	●	3	●	3	●	3	●	3	●	3	●	3	●	3	●	3	●	3	●	3	●	3	.5037	No. 4	48														
●	3	●	3	●	3	●	3	●	3	●	3	●	3	●	3	●	3	●	3	●	3	●	3	●	3	●	3	.5038	No. 5	44														
●	3	●	3	●	3	●	3	●	3	●	3	●	3	●	3	●	3	●	3	●	3	●	3	●	3	●	3	.5039	No. 6	40														
●	3	●	3	●	3	●	3	●	3	●	3	●	3	●	3	●	3	●	3	●	3	●	3	●	3	●	3	.5040	No. 8	36														
●	3	●	3	●	3	●	3	●	3	●	3	●	3	●	3	●	3	●	3	●	3	●	3	●	3	●	3	.5041	No. 10	32														
●	3	●	3	●	3	●	3	●	3	●	3	●	3	●	3	●	3	●	3	●	3	●	3	●	3	●	3	.5042	No. 12	28														
●	3	●	3	●	3	●	3	●	3	●	3	●	3	●	3	●	3	●	3	●	3	●	3	●	3	●	3	.5043	1/4	28														
●	3	●	3	●	3	●	3	●	3	●	3	●	3	●	3	●	3	●	3	●	3	●	3	●	3	●	3	.5044	5/16	24														
●	3	●	3	●	3	●	3	●	3	●	3	●	3	●	3	●	3	●	3	●	3	●	3	●	3	●	3	.5045	3/8	24														

CU973701						CU573701						CU583701						CU503700						CU50C400						CU94C400						CU513500						CU513700						Tool Identification		
Rekord 2D-Z- IKZ TIN		Flutes		Rekord 2D-Z- BF TIN		Flutes		Rekord 2D-Z- BF IKZ-TIN		Flutes		Enorm 2-Z TIN		Flutes		Enorm 2-Z GLT-1		Flutes		Enorm 2-Z- IKZ GLT-1		Flutes		Enorm 2-Z/E		Flutes		Enorm 2-Z/E TIN		Flutes		Dimens. ID	Nominal Size ø d ₁	T.P.I.																
●	3	●	3	●	3	●	3	●	3	●	3	●	4	●	4	●	4	●	4	●	4	●	4	●	4	●	4	●	4	●	4	.5046	7/16	20																
●	3	●	3	●	3	●	3	●	3	●	3	●	5	●	5	●	5	●	5	●	5	●	5	●	5	●	5	●	5	●	5	.5047	1/2	20																
●	3	●	3	●	3	●	3	●	3	●	3	●	5	●	5	●	5	●	5	●	5	●	5	●	5	●	5	●	5	●	5	.5048	9/16	18																
●	3	●	3	●	3	●	3	●	3	●	3	●	5	●	5	●	5	●	5	●	5	●	5	●	5	●	5	●	5	●	5	.5049	5/8	18																
●	4	●	4	●	4	●	4	●	4	●	4	●	5	●	5	●	5	●	5	●	5	●	5	●	5	●	5	●	5	●	5	.5050	3/4	16																
●	4	●	4	●	4	●	4	●	4	●	4	●	5	●	5	●	5	●	5	●	5	●	5	●	5	●	5	●	5	●	5	.5051	7/8	14																
●	4	●	4	●	4	●	4	●	4	●	4	●	5	●	5	●	5	●	5	●	5	●	5	●	5	●	5	●	5	●	5	.5052	1	12																
●	5	●	5	●	5	●	5	●	5	●	5	●	6	●	6	●	6	●	6	●	6	●	6	●	6	●	6	●	6	●	6	.5053	1 1/8	12																
●	6	●	6	●	6	●	6	●	6	●	6	●	6	●	6	●	6	●	6	●	6	●	6	●	6	●	6	●	6	●	6	.5054	1 1/4	12																
●	6	●	6	●	6	●	6	●	6	●	6	●	6	●	6	●	6	●	6	●	6	●	6	●	6	●	6	●	6	●	6	.5055	1 3/8	12																
●	6	●	6	●	6	●	6	●	6	●	6	●	6	●	6	●	6	●	6	●	6	●	6	●	6	●	6	●	6	●	6	.5056	1 1/2	12																

● = In stock
★ = Allow 7 days for delivery

- Product Finder
- V_c
- UNC
- UNF
- UNEF
- UN-8
- M
- MF
- NPSM/NPSC
- NPSF
- Rp (BSPP)
- G
- NPT
- NPTF
- Rc (BSPT)
- STI
- SELF-LOCK
- Accessories
- Tech. Info

DIN Length - ANSI Shank

Overall length acc. to DIN 371, DIN 374

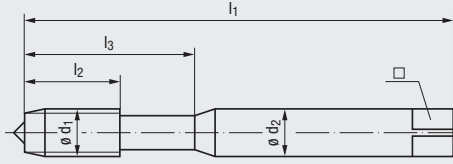

Reinforced Shank
(No.0 - 3/8)

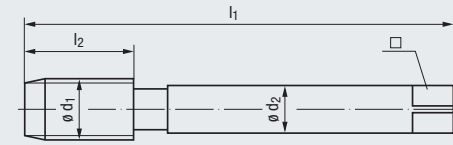

Reduced Shank
(7/16 - 1 1/2)

UNF

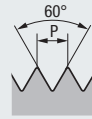

Unified Fine Thread
ASME B1.1

Class of Fit

Coating

Cutting Material

Technical Characteristics



Thread Depth
and Hole Shape

Applications - Material

Z
CNC-Controlled
Machines



2B	2B	2B	2B	3B
TICN	GLT-1	TICN	GLT-1	GLT-1
HSS Extra	HSS Extra	HSS Extra	HSS Extra	HSS Extra
R45	R45	R45	R45	R45
E / 1.5-2	E / 1.5-2	E / 1.5-2	E / 1.5-2	E / 1.5-2
E / O / P	E / O / P	E / O	E / O	E / O / P

max. 3 x d₁



P 1.1-4.1	P 1.1-4.1	P 1.1-4.1	P 1.1-4.1	P 1.1-4.1
M 1.1-3.1	M 1.1-3.1	M 1.1-3.1	M 1.1-3.1	M 1.1-3.1
N 1.4-6	N 1.4-6	N 1.4-6	N 1.4-6	N 1.4-6
N 2.1-2, 2.4-5	N 2.1-2, 2.4-5	N 2.1-2, 2.4-5	N 2.1-2, 2.4-5	N 2.1-2, 2.4-5
S 1.1	S 1.1	S 1.1	S 1.1	S 1.1

Reinforced Shank

Nominal Size ø d ₁	T.P.I.	l ₁	l ₂	inch		ø d ₂	□	Tool Identification		BU519400		BU51C400		BU999400		BU99C400		BU51C410	
				Dimens. ID	Enorm 1-Z/E TICN			Flutes	Enorm 1-Z/E GLT-1	Flutes	Enorm 1-Z/E-IKZ TICN	Flutes	Enorm 1-Z/E-IKZ GLT-1	Flutes	Enorm 1-Z/E GLT-1	Flutes			
No. 0	80	1.626	0.157	0.433	0.141	0.110	0.0480	.5033				●	2						
No. 1	72	1.772	0.157	0.472	0.141	0.110	0.0595	.5034				●	2						
No. 2	64	1.772	0.177	0.472	0.141	0.110	0.0730	.5035				●	2						
No. 3	56	1.969	0.197	0.551	0.141	0.110	0.0827	.5036				●	2						
No. 4	48	2.205	0.236	0.709	0.141	0.110	0.0945	.5037				●	2						
No. 5	44	2.205	0.276	0.709	0.141	0.110	0.1063	.5038				●	3						
No. 6	40	2.205	0.276	0.787	0.141	0.110	0.1181	.5039				●	3						
No. 8	36	2.480	0.315	0.827	0.168	0.131	0.1378	.5040				●	3						
No. 10	32	2.756	0.394	0.984	0.194	0.152	0.1614	.5041	●	3		●	3	●	3	●	3	●	3
No. 12	28	3.150	0.394	1.142	0.220	0.165	0.1820	.5042				●	3						
1/4	28	3.150	0.394	1.181	0.255	0.191	0.2165	.5043	●	3		●	3	●	3	●	3	●	3
5/16	24	3.543	0.394	1.260	0.318	0.238	0.2717	.5044	●	3		●	3	●	3	●	3	●	3
3/8	24	3.937	0.394	1.535	0.381	0.286	0.3346	.5045	●	3		●	3	●	3	●	3	●	3

Reduced Shank

Nominal Size ø d ₁	T.P.I.	l ₁	l ₂	inch		ø d ₂	□	Tool Identification		CU519400		CU51C400		CU999400		CU99C400		CU51C410		
				Dimens. ID	Enorm 2-Z/E TICN			Flutes	Enorm 2-Z/E GLT-1	Flutes	Enorm 2-Z/E-IKZ TICN	Flutes	Enorm 2-Z/E-IKZ GLT-1	Flutes	Enorm 2-Z/E GLT-1	Flutes				
7/16	20	3.937	0.512	—	0.323	0.242	0.3898	.5046	●	4	●	4	●	4	●	4	●	4	●	4
1/2	20	3.937	0.512	—	0.367	0.275	0.4528	.5047	●	5	●	5	●	5	●	5	●	5	●	5
9/16	18	3.937	0.591	—	0.429	0.322	0.5118	.5048	●	5	●	5	●	5	●	5	●	5	●	5
5/8	18	3.937	0.591	—	0.480	0.360	0.5709	.5049	●	5	●	5	●	5	●	5	●	5	●	5
3/4	16	4.331	0.669	—	0.590	0.442	0.6890	.5050	●	5	●	5	●	5	●	5	●	5	●	5
7/8	14	4.921	0.669	—	0.697	0.523	0.8071	.5051												
1	12	5.512	0.787	—	0.800	0.600	0.9219	.5052												
1 1/8	12	5.906	0.866	—	0.896	0.672	1.0433	.5053												
1 1/4	12	5.906	0.866	—	1.021	0.766	1.1719	.5054												
1 3/8	12	6.693	0.945	—	1.108	0.831	1.2992	.5055												
1 1/2	12	6.693	0.984	—	1.233	0.925	1.4173	.5056												

Z
CNC-Controlled
Machines

new



SPEED
High-Speed
Cutting

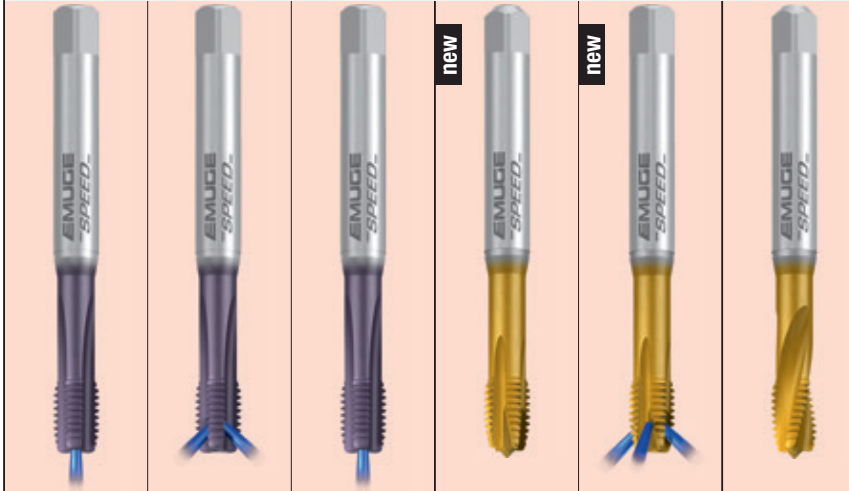

- 3B**
- GLT-1
- HSS Extra
- R45
- E / 1.5-2**
- E / O

- | | | | | | | |
|-----------|-----------|------------------|----------------|----------------|-----------|-----|
| 2BX | 2BX | 2BX | 2BX | 2BX | 2BX | 2BX |
| TICN | TICN | TICN | TIN-70 | TIN-70 | TIN | |
| HSS Extra | HSS Extra | HSS Extra | HSSE-PM | HSSE-PM | HSS Extra | |
| C / 2-3 | C / 2-3 | E / 1.5-2 | B / 4-5 | B / 4-5 | R15 | |
| E | E | E | E | E | C / 2-3 | |
| | | | | | E | |

Class of Fit
Coating
Cutting Material
Technical Characteristics

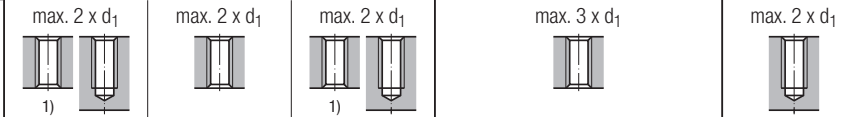
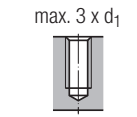

Thread Depth
and Hole Shape

- P 1.1-4.1**
- M 1.1-3.1**
- N 1.4-6**
- N 2.1-2, 2.4-5**
- S 1.1**

- | | | | | | |
|------------------|------------------|------------------|------------------|------------------|------------------|
| K 1.1-4.2 | K 1.1-4.2 | K 1.1-4.2 | P 1.1-4.1 | P 1.1-4.1 | P 1.1-4.1 |
| N 1.4-6 | N 1.4-6 | N 1.4-6 | K 2.1-2 | K 2.1-2 | M 1.1-3.1 |
| | | | N 1.4-6 | N 1.4-6 | K 2.1-2 |
| | | | | | N 1.4-2.1 |

Applications – Material

BU99C410		BW159401		BW179401		BW169401		BW138F01		BW208F01		BU263701		Tool Identification		
Enorm 1-Z/E-IKZ GLT-1	Flutes	Rekord 1A-SPEED IKZ-TICN	Flutes	Rekord 1A-SPEED IKZN-TICN	Flutes	Rekord 1A-SPEED/E IKZ-TICN	Flutes	Rekord 1B-Z-SPEED PM-TIN-70	Flutes	Rekord 1B-Z-SPEED IKZN-PM TIN-70	Flutes	Rekord 1D-SPEED TIN	Flutes	Dimens. ID	Nominal Size ø d ₁	T.P.I.
														.5033	No. 0	80
														.5034	No. 1	72
														.5035	No. 2	64
														.5036	No. 3	56
														.5037	No. 4	48
														.5038	No. 5	44
														.5039	No. 6	40
														.5040	No. 8	36
●	3	●	3	●	3	●	3	●	3	●	3	●	3	.5041	No. 10	32
		●	3	●	3	●	3	●	3	●	3	●	3	.5042	No. 12	28
●	3	●	3	●	3	●	3	●	3	●	3	●	3	.5043	1/4	28
●	3	●	3	●	3	●	3	●	4	●	4	●	3	.5044	5/16	24
●	3	●	4	●	4	●	4	●	4	●	4	●	3	.5045	3/8	24

CU99C410		CW159401		CW179401		CW169401		CW138F01		CW208F01		CU263701		Tool Identification		
Enorm 2-Z/E-IKZ GLT-1	Flutes	Rekord 2A-SPEED IKZ-TICN	Flutes	Rekord 2A-SPEED IKZN-TICN	Flutes	Rekord 2A-SPEED/E IKZ-TICN	Flutes	Rekord 2B-Z-SPEED PM-TIN-70	Flutes	Rekord 2B-Z-SPEED IKZN-PM TIN-70	Flutes	Rekord 2D-SPEED TIN	Flutes	Dimens. ID	Nominal Size ø d ₁	T.P.I.
●	4	●	4	●	4	●	4	●	4	●	4	●	3	.5046	7/16	20
●	5	●	4	●	4	●	4	●	4	●	4	●	3	.5047	1/2	20
●	5	●	4	●	4	●	4	●	4	●	4	●	3	.5048	9/16	18
●	5	●	4	●	4	●	4	●	4	●	4	●	3	.5049	5/8	18
●	5	●	4	●	4	●	4	●	4	●	4	●	4	.5050	3/4	16
														.5051	7/8	14
														.5052	1	12
														.5053	1 1/8	12
														.5054	1 1/4	12
														.5055	1 3/8	12
														.5056	1 1/2	12

● = In stock
★ = Allow 7 days for delivery

1) Threading in through holes is possible only with external cooling/lubrication



- Product Finder
- V_c
- UNC
- UNF**
- UNEF
- UN-8
- MF
- NPSM/NPSC
- NPSF
- R_p (BSPP)
- G
- NPT
- NPTF
- R_c (BSPT)
- STI
- SELF-LOCK
- Accessories
- Tech. Info

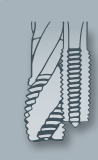

- Product Finder
- V_c
- UNC
- UNF
- UNEF
- UN-8
- M
- MF
- NPSM/NPSC
- NPSF
- Rp (BSPP)
- G
- NPT
- NPTF
- Rc (BSPT)
- STI
- SELF-LOCK
- Accessories
- Tech. Info

DIN Length - ANSI Shank

Overall length acc. to DIN 371, DIN 374

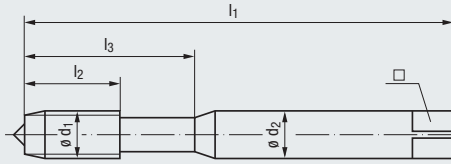

Reinforced Shank
(No.0 - 3/8)

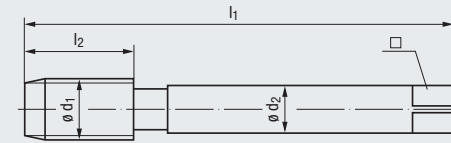

Reduced Shank
(7/16 - 1 1/2)

SPEED

High-Speed Cutting



Unified Fine Thread ASME B1.1

Class of Fit
Coating
Cutting Material
Technical Characteristics

Thread Depth and Hole Shape

Applications - Material

2BX	2B
TIN	TIN
HSS Extra	HSS Extra
R15	R45
C / 2-3	C / 2-3
E	E

max. 2 x d ₁	max. 3 x d ₁

P 1.1-4.1	P 1.1-4.1
M 1.1-3.1	M 1.1-3.1
K 2.1-2	K 2.1
N 1.4-2.1	N 1.1-2.2

Reinforced Shank

								Tool Identification		BU293701		BW553700	
Nominal Size ø d ₁	T.P.I.	l ₁	l ₂	inch l ₃	ø d ₂	□		Dimens. ID	Rekord	Enorm	Flutes	Flutes	
									1D-SPEED IKZ-TIN	1-SPEED IKZ-TIN			
No. 0	80	1.626	0.157	0.433	0.141	0.110	0.0480	.5033					
No. 1	72	1.772	0.157	0.472	0.141	0.110	0.0595	.5034					
No. 2	64	1.772	0.177	0.472	0.141	0.110	0.0730	.5035					
No. 3	56	1.969	0.197	0.551	0.141	0.110	0.0827	.5036					
No. 4	48	2.205	0.236	0.709	0.141	0.110	0.0945	.5037					
No. 5	44	2.205	0.276	0.709	0.141	0.110	0.1063	.5038					
No. 6	40	2.205	0.276	0.787	0.141	0.110	0.1181	.5039					
No. 8	36	2.480	0.315	0.827	0.168	0.131	0.1378	.5040					
No. 10	32	2.756	0.394	0.984	0.194	0.152	0.1614	.5041	●	●	3	3	
No. 12	28	3.150	0.394	1.142	0.220	0.165	0.1820	.5042					
1/4	28	3.150	0.394	1.181	0.255	0.191	0.2165	.5043	●	●	3	3	
5/16	24	3.543	0.394	1.260	0.318	0.238	0.2717	.5044	●	●	3	3	
3/8	24	3.937	0.394	1.535	0.381	0.286	0.3346	.5045	●	●	3	3	

Reduced Shank

								Tool Identification		CU293701		CW553700	
Nominal Size ø d ₁	T.P.I.	l ₁	l ₂	inch l ₃	ø d ₂	□		Dimens. ID	Rekord	Enorm	Flutes	Flutes	
									2D-SPEED IKZ-TIN	2-SPEED IKZ-TIN			
7/16	20	3.937	0.512	—	0.323	0.242	0.3898	.5046	●	●	3	4	
1/2	20	3.937	0.512	—	0.367	0.275	0.4528	.5047	●	●	3	5	
9/16	18	3.937	0.591	—	0.429	0.322	0.5118	.5048	●	●	3	5	
5/8	18	3.937	0.591	—	0.480	0.360	0.5709	.5049	●	●	3	5	
3/4	16	4.331	0.669	—	0.590	0.442	0.6890	.5050	●	●	4	5	
7/8	14	4.921	0.669	—	0.697	0.523	0.8071	.5051					
1	12	5.512	0.787	—	0.800	0.600	0.9219	.5052					
1 1/8	12	5.906	0.866	—	0.896	0.672	1.0433	.5053					
1 1/4	12	5.906	0.866	—	1.021	0.766	1.1719	.5054					
1 3/8	12	6.693	0.945	—	1.108	0.831	1.2992	.5055					
1 1/2	12	6.693	0.984	—	1.233	0.925	1.4173	.5056					

DIN Length • ANSI Shank

Overall length acc. to DIN 374

With internal chip collector

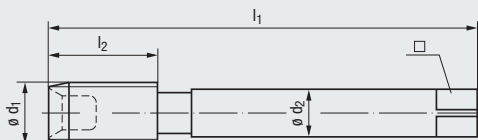

Reduced Shank

VA
Stainless Steel
Materials



UNF

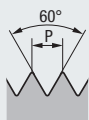

**Unified Fine Thread
ASME B1.1**

Class of Fit

3BX 2)

Coating

NE2

Cutting Material

HSS Extra

Technical Characteristics



C / 2-3



P / O 1)

Thread Depth
and Hole Shape

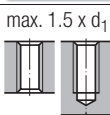

Applications – Material

P 1.1-4.1

M 1.1-2.1

K 1.1-4.2

Reduced Shank

Tool Identification

CU803011

Nominal Size ø d ₁	T.P.I.	inch				□	Image	Dimens. ID	Robust 2X-VA NE2	Flutes
		l ₁	l ₂	ø d ₂						
3/4	16	4.331	0.984	0.590	0.442	0.6890	.5050	●	5	
7/8	14	4.921	1.024	0.697	0.523	0.8071	.5051	●	5	
1	12	5.512	1.102	0.800	0.600	0.9219	.5052	●	5	
1 1/8	12	5.906	1.181	0.896	0.672	1.0433	.5053	●	5	
1 1/4	12	5.906	1.181	1.021	0.766	1.1719	.5054	●	6	
1 3/8	12	6.693	1.299	1.108	0.831	1.2992	.5055	●	6	
1 1/2	12	6.693	1.299	1.233	0.925	1.4173	.5056	●	6	

1) If possible, use paste lubrication, coating both the tool and the walls of the drilled hole.
Lubrication with oil is possible only in the vertical machining of blind holes, if the hole is entirely filled with oil.

2) Class 2B threads may be produced with 3BX taps.

Larger sizes priced upon request. We have experience in making taps as large as 10 inches ø UN.

The Complete Tool System

Robust 2X-VA Taps when used with a KSN Type tapping attachment creates the optimal tapping unit!

Product Finder

- Vc
- UNC
- UNF**
- UNEF
- UN-8
- ...
- MF
- NPSM/NPSC
- NPSF
- Rp (BSPP)
- G
- NPT
- NPTF
- Rc (BSPT)
- STI
- SELF-LOCK
- Accessories
- Tech. Info



- Product Finder
- V_c
- UNC
- UNF
- UNEF
- UN-8
- M
- MF
- NPSM/NPSC
- NPSF
- Rp (BSPP)
- G
- NPT
- NPTF
- Rc (BSPT)
- STI
- SELF-LOCK
- Accessories
- Tech. Info

ANSI Length · ANSI Shank

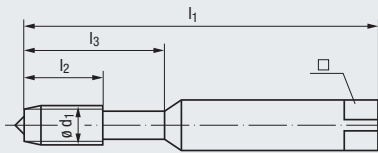

Reinforced Shank
(No.6 - 3/8)

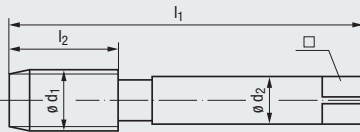

Reduced Shank
(7/16 - 3/4)

UNF

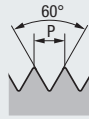

**Unified Fine Thread
ASME B1.1**

Class of Fit: 2B
Coating: TIN
Cutting Material: HSS Extra
Technical Characteristics: B / 4-5, E / O

Thread Depth and Hole Shape: max. 3 x d₁

Applications – Material

STEEL
Steel
Materials



VA
Stainless Steel
Materials



2B	3B	Override
NT	NT	NT
HSS Extra	HSS Extra	HSS Extra
B / 4-5	B / 4-5	B / 4-5
E / O / P	E / O / P	E / O / P

max. 3 x d₁



P 1.1-4.1	P 1.1-3.1	P 1.1-3.1	P 1.1-3.1
K 2.1	M 1.1-2.1	M 1.1-2.1	M 1.1-2.1
N 2.2, 2.4-5	K 2.1	K 2.1	K 2.1
	N 2.2, 2.5-6	N 2.2, 2.5-6	N 2.2, 2.5-6

Tool Identification

AU208400		AU203000		AU203010		AU203044	
Rekord B-STEEL-L TIN	Flutes	Rekord B-VA NT	Flutes	Rekord B-VA NT	Flutes	Rekord B-VA NT	Flutes

Nominal Size ϕd_1	T.P.I.	inch				ϕd_2	\square	Tool ID	Rekord B-STEEL-L TIN	Flutes	Rekord B-VA NT	Flutes	Rekord B-VA NT	Flutes	Rekord B-VA NT	Flutes	
		l_1	l_2	l_3	ϕd_2												
No. 6	40	2	2.00	0.472	0.748	0.141	0.110	0.1181	.5039	●	3	●	3	●	3	●	3
No. 8	36	2 1/8	2.13	0.512	0.827	0.168	0.131	0.1378	.5040	●	3	●	3	●	3	●	3
No. 10	32	2 3/8	2.38	0.591	0.945	0.194	0.152	0.1614	.5041	●	3	●	3	●	3	●	3
1/4	28	2 1/2	2.50	0.669	1.142	0.255	0.191	0.2165	.5043	●	3	●	3	●	3	●	3
5/16	24	2 23/32	2.72	0.669	1.299	0.318	0.238	0.2717	.5044	●	3	●	3	●	3	●	3
3/8	24	2 15/16	2.94	0.709	1.378	0.381	0.286	0.3346	.5045	●	4	●	4	●	4	●	4
7/16	20	3 5/32	3.16	0.866	—	0.323	0.242	0.3898	.5046	●	3	●	3	●	3	●	3
1/2	20	3 3/8	3.38	0.866	—	0.367	0.275	0.4528	.5047	●	3	●	3	●	3	●	3
9/16	18	3 19/32	3.59	0.866	—	0.429	0.322	0.5118	.5048	●	3	●	3	●	3	●	3
5/8	18	3 13/16	3.81	0.866	—	0.480	0.360	0.5709	.5049	●	3	●	3	●	3	●	3
3/4	16	4 1/4	4.25	0.984	—	0.590	0.442	0.6890	.5050	●	4	●	4	●	4	●	4

1) Tool Identification = AU203043

DIN Length · ANSI Shank



All ANSI Length · ANSI Shank taps are available in the popular DIN Length · ANSI Shank style.

The DIN Length · ANSI Shank configuration allows for added reach capabilities and greater chip clearance.

VA Stainless Steel Materials						TI Titanium						Product Finder								
												v _c								
												UNC								
												UNF								
												UNEF								
												UN-8								
												...								
												MF								
												NPSM/NPSC								
												NPSF								
												Rp (BSPP)								
												G								
												NPT								
												NPTF								
												Rc (BSPT)								
												STI								
												SELF-LOCK								
												Accessories								
												Tech. Info								
2B			3B			Oversize			2BX			3BX			Class of Fit					
NE2			NE2			NE2			NT2			NT2			Coating					
HSS Extra			HSS Extra			HSS Extra			HSS Extra			HSS Extra			Cutting Material					
R35			R35			R35			L15			L15			Technical Characteristics					
C / 2-3			C / 2-3			C / 2-3			D / 4-5			D / 4-5								
E / O / P			E / O / P			E / O / P			E / O / P			E / O / P								
max. 2.5 x d ₁						max. 3 x d ₁						max. 2 x d ₁						Thread Depth and Hole Shape		
P 1.1-3.1			P 1.1-3.1			P 1.1-3.1			P 4.1-5.1			P 4.1-5.1			P 4.1-5.1			Applications – Material		
M 1.1-2.1			M 1.1-2.1			M 1.1-2.1			M 3.1-4.1			M 3.1-4.1			M 3.1-4.1					
K 2.1			K 2.1			K 2.1			N 2.4-5, 2.7			N 2.4-5, 2.7			N 2.4-5, 2.7					
									S 1.1-2.2, 2.4			S 1.1-2.2, 2.4			S 1.1-2.2, 2.4					
AU503200		AU503210		AU503244		AU306001		AU306011		AU456001		AU456011		Tool Identification						
Enorm VA NE2	Flutes	Enorm VA NE2	Flutes	Enorm VA NE2	Flutes	Rekord C-TI NT2	Flutes	Rekord C-TI NT2	Flutes	Rekord D-TI NT2	Flutes	Rekord D-TI NT2	Flutes	Dimens. ID	Nominal Size ø d ₁	T.P.I.				
●	3					●	3			●	3			.5039	No. 6	40				
●	3					●	3			●	3			.5040	No. 8	36				
●	3	●	3	2) ● (+.0035)	3	●	3	●	3	●	3	●	3	.5041	No. 10	32				
●	3	●	3	● (+.0050)	3	●	3	●	3	●	3	●	3	.5043	1/4	28				
●	3	●	3	● (+.0050)	3	●	3	●	3	●	3	●	3	.5044	5/16	24				
●	3	●	3	● (+.0050)	3	●	3	●	3	●	3	●	3	.5045	3/8	24				
●	3	●	3	● (+.0050)	3	●	3	●	3	●	3	●	3	.5046	7/16	20				
●	4	●	4	● (+.0050)	4	●	3	●	3	●	3	●	3	.5047	1/2	20				
●	4	●	4			●	3	●	3	●	3	●	3	.5048	9/16	18				
●	4	●	4	● (+.0050)	4	●	3	●	3	●	3	●	3	.5049	5/8	18				
●	4	●	4			●	4	●	4	●	4	●	4	.5050	3/4	16				

2) Tool Identification = AU503243

- Product Finder
- V_c
- UNC
- UNF
- UNEF
- UN-8
- M
- MF
- NPSM/NPSC
- NPSF
- Rp (BSPP)
- G
- NPT
- NPTF
- Rc (BSPT)
- STI
- SELF-LOCK
- Accessories
- Tech. Info

ANSI Length • ANSI Shank

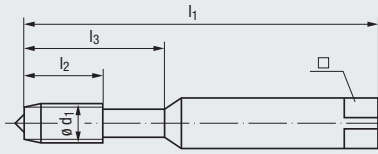

Reinforced Shank
(No.6 - 3/8)

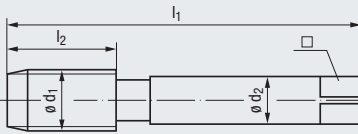

Reduced Shank
(7/16 - 3/4)

H Materials of High Tensile Strength	



UNF Unified Fine Thread ASME B1.1

Class of Fit
Coating
Cutting Material
Technical Characteristics

2BX	2BX
NT	TICN
HSS Extra	HSS Extra
C / 2-3	C / 2-3
E / O / P	E / O / P

Thread Depth and Hole Shape

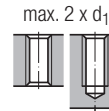

Applications – Material

P 1.1-3.1	P 1.1-4.1
K 1.1-4.2	K 1.1-4.2
N 2.4-7	N 2.4-7
N 4.1, 5.1	N 4.1, 5.1

Tool Identification

AU100501 AU109101

Nominal Size ø d ₁	T.P.I.	inch				ø d ₂	□	Tool ID	AU100501		AU109101		
		l ₁	l ₂	l ₃	□				Rekord A-H NT	Flutes	Rekord A-H TICN	Flutes	
No. 6	40	2	2.00	0.472	0.748	0.141	0.110	0.1181	.5039	●	3	●	3
No. 8	36	2 1/8	2.13	0.512	0.827	0.168	0.131	0.1378	.5040	●	3	●	3
No. 10	32	2 3/8	2.38	0.591	0.945	0.194	0.152	0.1614	.5041	●	3	●	3
1/4	28	2 1/2	2.50	0.669	1.142	0.255	0.191	0.2165	.5043	●	3	●	3
5/16	24	2 23/32	2.72	0.669	1.299	0.318	0.238	0.2717	.5044	●	3	●	3
3/8	24	2 15/16	2.94	0.709	1.378	0.381	0.286	0.3346	.5045	●	4	●	4
7/16	20	3 5/32	3.16	0.866	—	0.323	0.242	0.3898	.5046	●	4	●	4
1/2	20	3 3/8	3.38	0.866	—	0.367	0.275	0.4528	.5047	●	4	●	4
9/16	18	3 19/32	3.59	0.866	—	0.429	0.322	0.5118	.5048	●	4	●	4
5/8	18	3 13/16	3.81	0.866	—	0.480	0.360	0.5709	.5049	●	4	●	4
3/4	16	4 1/4	4.25	0.984	—	0.590	0.442	0.6890	.5050	●	4	●	4

ANSI Length • ANSI Shank

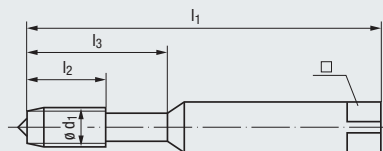

Reinforced Shank
(No.6 - 3/8)

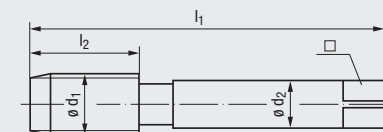

Reduced Shank
(7/16 - 3/4)

UNF
Unified Fine Thread
ASME B1.1

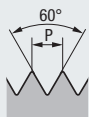

Class of Fit
Coating
Cutting Material
Technical Characteristics



Thread Depth
and Hole Shape

max. 3 x d₁



Applications – Material

P 1.1-4.1	P 1.1-4.1	P 1.1-4.1	P 1.1-4.1
M 1.1-2.1	M 1.1-3.1	M 1.1-2.1	M 1.1-3.1
N 2.1	N 1.4-6	N 2.1	N 1.4-6
	N 2.1-2, 2.4-5		N 2.1-2, 2.4-5
	S 1.1		S 1.1

Tool Identification

AU513500	AU513700	AU513510	AU513710
-----------------	-----------------	-----------------	-----------------

Nominal Size ø d ₁	T.P.I.	inch						□	Dimens. ID	AU513500		AU513700		AU513510		AU513710	
		l ₁	l ₂	l ₃	ø d ₂	Enorm Z/E	Flutes			Enorm Z/E TIN	Flutes	Enorm Z/E	Flutes	Enorm Z/E TIN	Flutes		
No. 6	40	2	2.00	0.276	0.748	0.141	0.110	0.1181	.5039	●	3	●	3				
No. 8	36	2 1/8	2.13	0.315	0.827	0.168	0.131	0.1378	.5040	●	3	●	3				
No. 10	32	2 3/8	2.38	0.354	0.945	0.194	0.152	0.1614	.5041	●	3	●	3	●	3	●	3
1/4	28	2 1/2	2.50	0.394	1.142	0.255	0.191	0.2165	.5043	●	3	●	3	●	3	●	3
5/16	24	2 23/32	2.72	0.394	1.299	0.318	0.238	0.2717	.5044	●	3	●	3	●	3	●	3
3/8	24	2 15/16	2.94	0.394	1.378	0.381	0.286	0.3346	.5045	●	3	●	3	●	3	●	3
7/16	20	3 5/32	3.16	0.512	—	0.323	0.242	0.3898	.5046	●	4	●	4	●	4	●	4
1/2	20	3 3/8	3.38	0.512	—	0.367	0.275	0.4528	.5047	●	5	●	5	●	5	●	5
9/16	18	3 19/32	3.59	0.591	—	0.429	0.322	0.5118	.5048	●	5	●	5	●	5	●	5
5/8	18	3 13/16	3.81	0.591	—	0.480	0.360	0.5709	.5049	●	5	●	5	●	5	●	5
3/4	16	4 1/4	4.25	0.669	—	0.590	0.442	0.6890	.5050	●	5	●	5	●	5	●	5

- Product Finder
- V_c
- UNC
- UNF**
- UNEF
- UN-8
- ...
- MF
- NPSM/NPSC
- NPSF
- R_p (BSPP)
- G
- NPT
- NPTF
- R_c (BSPT)
- STI
- SELF-LOCK
- Accessories
- Tech. Info



DIN Length • ANSI Shank



All ANSI Length • ANSI Shank taps are available in the popular DIN Length • ANSI Shank style.

The DIN Length • ANSI Shank configuration allows for added reach capabilities and greater chip clearance.

● = In stock
★ = Allow 7 days for delivery

- Product Finder
- V_c
- UNC
- UNF
- UNEF
- UN-8
- M
- MF
- NPSM/NPSC
- NPSF
- Rp (BSPP)
- G
- NPT
- NPTF
- Rc (BSPT)
- STI
- SELF-LOCK
- Accessories
- Tech. Info

DIN Length · DIN Shank

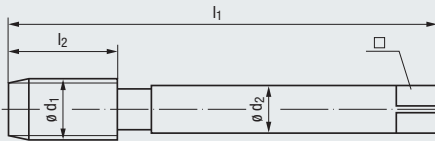

Reduced Shank

STEEL

Steel Materials

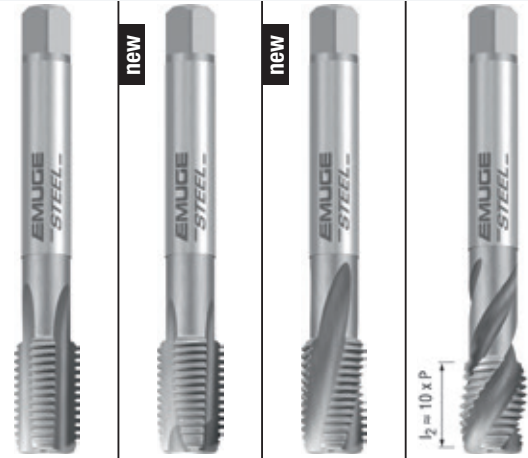

UNEF

Unified Extra Fine Thread
ASME B1.1

Class of Fit
Coating
Cutting Material
Technical Characteristics



Thread Depth and Hole Shape

Applications – Material

2BX	2B	2B	2B
HSS Extra	HSS Extra	HSS Extra	HSS Extra
C / 2-3	B / 4-5	E / 1.5-2	C / 2-3
E / 0	E / 0	E / 0	E / 0
max. 2 x d ₁	max. 3 x d ₁	max. 2 x d ₁	max. 2.5 x d ₁
P 1.1-3.1 N 2.3	P 1.1-3.1 N 2.2	P 2.1-3.1	P 1.1-3.1 N 2.2

Reduced Shank

Nominal Size ø d ₁	T.P.I.	mm				□	Tool Identification	C0101001		C0208900		C0461000		C0501000	
		l ₁	l ₂	ø d ₂	□			Rekord 2A-STEEL	Flutes	Rekord 2B-STEEL-L	Flutes	Rekord 2D-STEEL/E	Flutes	Enorm 2-STEEL	Flutes
1/4	32	80	14	4.5	3.4	5.55	.5058	★	3	★	3	★	3	★	3
5/16	32	80	14	6	4.9	7.15	.5059	★	3	★	3	★	3	★	3
3/8	32	90	18	7	5.5	8.7	.5060	★	4	★	4	★	3	★	4
7/16	28	90	18	8	6.2	10.2	.5061	★	4	★	4	★	3	★	3
1/2	28	100	18	9	7	11.8	.5062	★	4	★	4	★	3	★	4
9/16	24	100	18	11	9	13.2	.5063	★	5	★	4	★	4	★	4
5/8	24	100	18	12	9	14.8	.5064	★	5	★	4	★	4	★	4
3/4	20	110	25	14	11	17.8	.5066	★	4	★	4	★	4	★	4
7/8	20	125	25	18	14.5	20.95	.5068	★	4	★	4	★	4	★	4
1	20	140	28	18	14.5	24.15	.5070	★	4	★	4	★	4	★	5

DIN Length • ANSI Shank

Overall length acc. to DIN 376

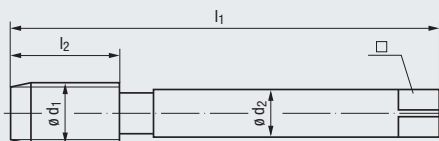

Reduced Shank

UN-8

Unified Thread
ASME B1.1

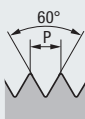

Class of Fit
Coating
Cutting Material
Technical Characteristics



Thread Depth
and Hole Shape

Applications – Material

VA
Stainless Steel
Materials



2B	2B	2B	3B	3B
GLT-1	TICN	NE2	NE2	GLT-1
HSS Extra	HSS Extra	HSS Extra	HSS Extra	HSS Extra
B / 4-5	B / 4-5	R35	R35	R35
E / O / P	E / O / P	C / 2-3	C / 2-3	C / 2-3
E / O / P	E / O / P	E / O / P	E / O / P	E / O / P

max. 3 x d₁



max. 2.5 x d₁



P 1.1-4.1	P 1.1-4.1	P 1.1-3.1	P 1.1-3.1	P 1.1-4.1
M 1.1-2.1	M 1.1-3.1	M 1.1-2.1	M 1.1-2.1	M 1.1-3.1
K 2.1	K 2.1	K 2.1	K 2.1	K 2.1
N 2.2, 2.5-6	N 2.2, 2.5-6			

Reduced Shank

Tool Identification

Nominal Size ø d ₁	T.P.I.	inch				□	Image	Dimens. ID	CU20C300		CU209300		CU503200		CU503210		CU50C310	
		l ₁	l ₂	ø d ₂	□				Rekord 2B-VA GLT-1	Flutes	Rekord 2B-VA TICN	Flutes	Enorm 2-VA NE2	Flutes	Enorm 2-VA NE2	Flutes	Enorm 2-VA GLT-1	Flutes
1	8	6.299	1.417	0.800	0.600	0.8750	.5018	●	3	●	3	●	4	●	4	●	4	
1 1/8	8	7.087	1.575	0.896	0.672	1.0000	.5247	●	4	●	4	●	4	●	4	●	4	
1 1/4	8	7.087	1.575	1.021	0.766	1.1250	.5249	●	4	●	4	●	4	●	4	●	4	
1 3/8	8	7.874	1.654	1.108	0.831	1.2500	.5251	●	4	●	4	●	5	●	5	●	5	
1 1/2	8	7.874	1.654	1.233	0.925	1.3750	.5253	●	4	●	4	●	5	●	5	●	5	
1 5/8	8	7.874	1.772	1.305	0.979	1.5000	.5255	●	4	●	4	●	5	●	5	●	5	
1 3/4	8	7.874	1.772	1.430	1.072	1.6250	.5257					●	6	●	6	●	6	
1 7/8	8	8.858	1.969	1.519	1.139	1.7500	.5259					●	6	●	6	●	6	
2	8	8.858	1.969	1.644	1.233	1.8750	.5261					●	6	●	6	●	6	
2 1/2	8	10.827	2.165	2.100	1.575	2.3750	.5265											

- Product Finder
- Vc
- UNC
- UNF
- UNEF
- UN-8**
- MF
- NPSM/NPSC
- NPSF
- Rp (BSPP)
- G
- NPT
- NPTF
- Rc (BSPT)
- STI
- SELF-LOCK
- Accessories
- Tech. Info



● = In stock
★ = Allow 7 days for delivery

- Product Finder
- V_c
- UNC
- UNF
- UNEF
- UN-8**
- M
- MF
- NPSM/NPSC
- NPSF
- Rp (BSPP)
- G
- NPT
- NPTF
- Rc (BSPT)
- STI
- SELF-LOCK
- Accessories
- Tech. Info

DIN Length - ANSI Shank

Overall length acc. to DIN 376

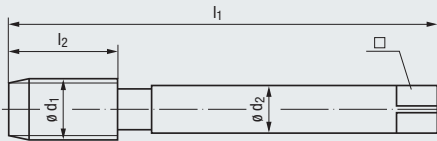

Reduced Shank

TI
Titanium



H
Materials of High Tensile Strength



UN-8



**Unified Thread
ASME B1.1**

Class of Fit
Coating
Cutting Material
Technical Characteristics



Thread Depth and Hole Shape

Applications - Material

- 2BX
- NT2
- HSS Extra
- R15
- C / 2-3
- E / O / P

- 2BX
- NT
- HSS Extra
- C / 2-3
- E / O / P

max. 2 x d₁



max. 2 x d₁

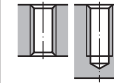

- P** 4.1-5.1
- M** 3.1-4.1
- N** 2.4-5, 2.7
- S** 1.1-2.2, 2.4

- P** 1.1-3.1
- K** 1.1-4.2
- N** 2.4-7
- N** 4.1, 5.1

Reduced Shank

Tool Identification

CU456001

CU100501

Nominal Size ø d ₁	T.P.I.	inch				□	Dimens. ID	CU456001		CU100501	
		l ₁	l ₂	ø d ₂	□			Rekord 2D-TI NT2	Flutes	Rekord 2A-H NT	Flutes
1	8	6.299	1.417	0.800	0.600	0.8750	.5018	●	3	●	4
1 1/8	8	7.087	1.575	0.896	0.672	1.0000	.5247	●	4	●	4
1 1/4	8	7.087	1.575	1.021	0.766	1.1250	.5249	●	4	●	4
1 3/8	8	7.874	1.654	1.108	0.831	1.2500	.5251	●	4	●	4
1 1/2	8	7.874	1.654	1.233	0.925	1.3750	.5253	●	4	●	4
1 5/8	8	7.874	1.772	1.305	0.979	1.5000	.5255	●	4	●	4
1 3/4	8	7.874	1.772	1.430	1.072	1.6250	.5257	●		●	5
1 7/8	8	8.858	1.969	1.519	1.139	1.7500	.5259	●		●	6
2	8	8.858	1.969	1.644	1.233	1.8750	.5261	●	6	●	6
2 1/2	8	10.827	2.165	2.100	1.575	2.3750	.5265	●		●	6

DIN Length • ANSI Shank

Overall length acc. to DIN 376

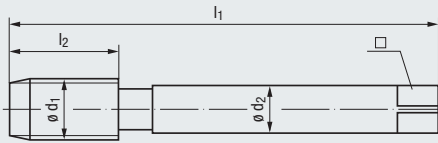

Reduced Shank

Z
CNC-Controlled
Machines



UN-8

Unified Thread
ASME B1.1



Class of Fit
Coating
Cutting Material
Technical Characteristics



2BX	2BX	2B	2B
TIN	TIN	TIN	GLT-1
HSS Extra	HSS Extra	HSS Extra	HSS Extra
R15	R15	R45	R45
C / 2-3	C / 2-3	C / 2-3	C / 2-3
E / O / P	E / O	E / O / P	E / O / P

Thread Depth
and Hole Shape

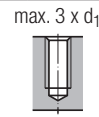
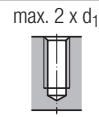

Applications – Material

P 2.1-5.1	P 2.1-5.1	P 1.1-4.1	P 1.1-4.1
K 2.1-2	K 2.1-2	M 1.1-3.1	M 1.1-3.1
N 1.4-6, 2.4-5	N 1.4-6, 2.4-5	N 1.4-6	N 1.4-6
		N 2.1-2, 2.4-5	N 2.1-2, 2.4-5
		S 1.1	S 1.1

Reduced Shank

Nominal Size ø d ₁	T.P.I.	inch				Tool Identification		CU573701		CU583701		CU503700		CU50C400	
		l ₁	l ₂	ø d ₂	□	Dimens. ID	Rekord 2D-Z-BF TIN	Flutes	Rekord 2D-Z-BF IKZ-TIN	Flutes	Enorm 2-Z TIN	Flutes	Enorm 2-Z GLT-1	Flutes	
1	8	6.299	1.417	0.800	0.600	0.8750	.5018	●	3	●	3	● ¹⁾	5	● ²⁾	5
1 1/8	8	7.087	1.575	0.896	0.672	1.0000	.5247	●	4	●	4	●	5	●	5
1 1/4	8	7.087	1.575	1.021	0.766	1.1250	.5249	●	4	●	4	●	5	●	5
1 3/8	8	7.874	1.654	1.108	0.831	1.2500	.5251	●	4	●	4	●	6	●	6
1 1/2	8	7.874	1.654	1.233	0.925	1.3750	.5253	●	4	●	4	●	6	●	6
1 5/8	8	7.874	1.772	1.305	0.979	1.5000	.5255	●	4	●	4	●	6	●	6
1 3/4	8	7.874	1.772	1.430	1.072	1.6250	.5257	●	5	●	5	●	8	●	8
1 7/8	8	8.858	1.969	1.519	1.139	1.7500	.5259	●	6	●	6	●	8	●	8
2	8	8.858	1.969	1.644	1.233	1.8750	.5261	●	6	●	6	●	8	●	8
2 1/2	8	10.827	2.165	2.100	1.575	2.3750	.5265	●	6	●	6	●	8	●	8

1) Chamfer form/threads = E/1.5-2, Tool Identification = CU513700
2) Chamfer form/threads = E/1.5-2, Tool Identification = CU51C400

- Product Finder
- V_c
- UNC
- UNF
- UNEF
- UN-8**
- ...
- MF
- NPSM/NPSC
- NPSF
- R_p (BSPP)
- G
- NPT
- NPTF
- R_c (BSPT)
- STI
- SELF-LOCK
- Accessories
- Tech. Info



- Product Finder
- V_c
- UNC
- UNF
- UNEF
- UN-8**
- M
- MF
- NPSM/NPSC
- NPSF
- Rp (BSPP)
- G
- NPT
- NPTF
- Rc (BSPT)
- STI
- SELF-LOCK
- Accessories
- Tech. Info

DIN Length - ANSI Shank

Overall length acc. to DIN 376

VA
Stainless Steel
Materials



With internal chip collector

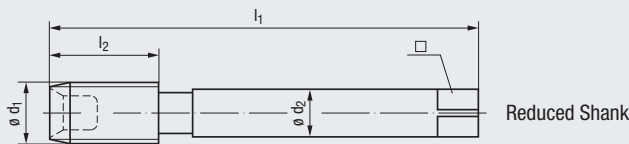

UN-8

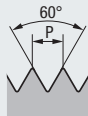

Unified Thread
ASME B1.1

Class of Fit

3BX 2)

Coating

NE2

Cutting Material

HSS Extra

Technical Characteristics



C / 2-3

P / O 1)

Thread Depth
and Hole Shape

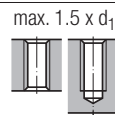

Applications - Material

P 1.1-4.1

M 1.1-2.1

K 1.1-4.2

Reduced Shank

Tool Identification

CU803011

Nominal Size ø d ₁	T.P.I.	inch		ø d ₂	□	Image	Dimens. ID	Robust 2X-VA NE2	Flutes
		l ₁	l ₂						
1	8	6.299	1.417	0.800	0.600	0.8750	.5018	●	5
1 1/8	8	7.087	1.575	0.896	0.672	1.0000	.5247	●	5
1 1/4	8	7.087	1.575	1.021	0.766	1.1250	.5249	●	6
1 3/8	8	7.874	1.654	1.108	0.831	1.2500	.5251	●	6
1 1/2	8	7.874	1.654	1.233	0.925	1.3750	.5253	●	6
1 5/8	8	7.874	1.772	1.305	0.979	1.5000	.5255	●	6
1 3/4	8	7.874	1.772	1.430	1.072	1.6250	.5257	●	6
1 7/8	8	8.858	1.969	1.519	1.139	1.7500	.5259	●	6
2	8	8.858	1.969	1.644	1.233	1.8750	.5261	●	6
2 1/4	8	9.843	1.969	1.894	1.420	2.1250	.5263	●	7
2 1/2	8	10.827	2.165	2.100	1.575	2.3750	.5265	●	7
3	8	11.810	2.165	2.100	1.575	2.8750	.5269	●	8
3 1/2	8	12.795	2.362	2.350	1.762	3.3750	.5273	●	10
4	8	13.780	2.362	2.350	1.762	3.8750	.5277	●	10
4 1/2	8	13.780	2.559	2.350	1.762	4.3750	.5281	●	10

1) If possible, use paste lubrication, coating both the tool and the walls of the drilled hole. Lubrication with oil is possible only in the vertical machining of blind holes, if the hole is entirely filled with oil.

2) Class 2B threads may be produced with 3BX taps.

Larger sizes priced upon request. We have experience in making taps as large as 10 inches ø UN.

The Complete Tool System

Robust 2X-VA Taps when used with a KSN Type tapping attachment creates the optimal tapping unit!

DIN Length • DIN Shank

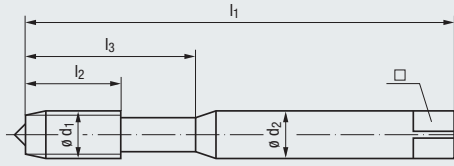

Reinforced Shank (M2 - M10)

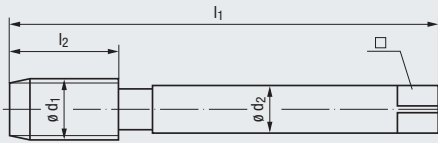

Reduced Shank (M12 - M52)

M
ISO Metric Coarse Thread
DIN 13



Class of Fit
Coating
Cutting Material
Technical Characteristics



Thread Depth and Hole Shape

Applications – Material

STEEL
Steel
Materials



ISO 2/6H	ISO 2/6H	ISO 2/6H	ISO 3/6G	7G
HSS Extra	HSS Extra	HSS Extra	HSS Extra	HSS Extra
B / 4-5	B / 4-5	B / 4-5	B / 4-5	B / 4-5
E / 0	E / 0	E / 0	E / 0	E / 0

max. 3 x d₁



P 1.1-3.1 N 2.2	P 1.1-4.1 K 2.1 N 2.2, 2.4-5	P 1.1-4.1 K 2.1	P 1.1-3.1 N 2.2	P 1.1-3.1 N 2.2
--------------------	------------------------------------	--------------------	--------------------	--------------------

Reinforced Shank

Nominal Size ϕd_1	P	l ₁	mm			ϕd_2	\square	Tool Identification		B0208900		B0208400		B020K500		B0208920		B0208930	
			l ₂	l ₃	ϕd_2			\square	Rekord 1B-STEEL-L	Flutes	Rekord 1B-STEEL-L TIN	Flutes	Rekord 1B-STEEL-L GLT-1	Flutes	Rekord 1B-STEEL-L	Flutes	Rekord 1B-STEEL-L	Flutes	
M 2	0.4	45	7	12	2.8	2.1	1.6	.0020	●	2	●	2	●	2	★	2	★	2	
M 2.5	0.45	50	9	14	2.8	2.1	2.05	.0025	●	2	●	2	●	2	★	2	★	2	
M 3	0.5	56	11	18	3.5	2.7	2.5	.0030	●	3	●	3		★	3	★	3		
M 3.5	0.6	56	12	20	4	3	2.9	.0035	●	3	●	3		★	3	★	3		
M 4	0.7	63	13	21	4.5	3.4	3.3	.0040	●	3	●	3		★	3	★	3		
M 4.5	0.75	70	14	25	6	4.9	3.7	.0045	●	3	●	3		★	3	★	3		
M 5	0.8	70	15	25	6	4.9	4.2	.0050	●	3	●	3		★	3	★	3		
M 6	1	80	17	30	6	4.9	5	.0060	●	3	●	3		★	3	★	3		
M 8	1.25	90	20	35	8	6.2	6.8	.0080	●	3	●	3		★	3	★	3		
M 10	1.5	100	22	39	10	8	8.5	.0100	●	3	●	3		★	3	★	3		

Reduced Shank

Nominal Size ϕd_1	P	l ₁	mm			ϕd_2	\square	Tool Identification		C0208900		C0208400		C0208920		C0208930	
			l ₂	l ₃	ϕd_2			\square	Rekord 2B-STEEL-L	Flutes	Rekord 2B-STEEL-L TIN	Flutes	Rekord 2B-STEEL-L	Flutes	Rekord 2B-STEEL-L	Flutes	
M 12	1.75	110	24	—	9	7	10.2	.0112	●	3	●	3		★	3	★	3
M 14	2	110	26	—	11	9	12	.0114	●	3	●	3		★	3	★	3
M 16	2	110	27	—	12	9	14	.0116	●	3	●	3		★	3	★	3
M 18	2.5	125	30	—	14	11	15.5	.0118	●	3	●	3		★	3	★	3
M 20	2.5	140	32	—	16	12	17.5	.0120	●	3	●	3		★	3	★	3
M 22	2.5	140	32	—	18	14.5	19.5	.0122	●	3	●	3		★	3	★	3
M 24	3	160	34	—	18	14.5	21	.0124	●	3	●	3		★	3	★	3
M 27	3	160	36	—	20	16	24	.0127	★	3	★	3					
M 30	3.5	180	40	—	22	18	26.5	.0130	★	4	★	4					
M 33	3.5	180	40	—	25	20	29.5	.0133	★	4	★	4					
M 36	4	200	50	—	28	22	32	.0136	★	4	★	4					
M 42	4.5	200	56	—	32	24	37.5	.0142	★	4	★	4					
M 45	4.5	220	58	—	36	29	40.5	.0145	★	4	★	4					
M 48	5	250	65	—	36	29	43	.0148	★	4	★	4					
M 52	5	250	65	—	40	32	47	.0152	★	4	★	4					

● = In stock
★ = Allow 7 days for delivery

- Product Finder
- V_c
- UNC
- UNF
- UNEF
- UN-8
- M**
- MF
- NPSM/NPSC
- NPSF
- Rp (BSPP)
- G
- NPT
- NPTF
- Rc (BSPT)
- STI
- SELF-LOCK
- Accessories
- Tech. Info

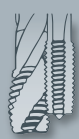

- Product Finder
- V_c
- UNC
- UNF
- UNEF
- UN-8
- M
- MF
- NPSM/NPSC
- NPSF
- Rp (BSPP)
- G
- NPT
- NPTF
- Rc (BSPT)
- STI
- SELF-LOCK
- Accessories
- Tech. Info

DIN Length • DIN Shank

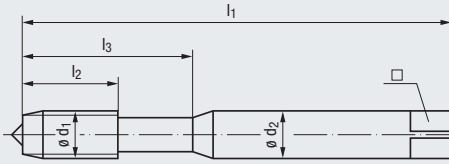

Reinforced Shank (M2 - M10)

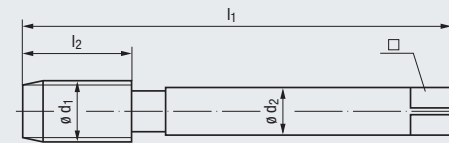

Reduced Shank (M12 - M52)

M

ISO Metric Coarse Thread DIN 13

Class of Fit
Coating
Cutting Material
Technical Characteristics



Thread Depth and Hole Shape

Applications – Material

new	STEEL Steel Materials				
	ISO 2/6H	ISO 2/6H	ISO 2/6H	ISO 2/6H	ISO 3/6G
	HSS Extra	HSS Extra	HSS Extra	HSS Extra	HSS Extra
	LH	R15	R35	R35	R35
	B / 4-5	E / 1.5-2	C / 2-3	C / 2-3	C / 2-3
	E / 0	E / 0	E / 0	E / 0	E / 0
	max. 3 x d ₁	max. 2 x d ₁	max. 2.5 x d ₁		
	P 1.1-3.1 N 2.2	P 1.1-4.1 K 1.1-4.2 N 1.4-5, 2.4-5	P 1.1-3.1 N 2.2	P 1.1-4.1 K 2.1 N 2.2	P 1.1-3.1 N 2.2



Reinforced Shank

Nominal Size ø d ₁	P	mm					□	Tool Identification	B0208950		B0461400		B0501000		B0501400		B0501020	
		l ₁	l ₂	l ₃	ø d ₂	□			Rekord 1B-STEEL-L LH	Flutes	Rekord 1D-STEEL/E TIN	Flutes	Enorm 1-STEEL	Flutes	Enorm 1-STEEL TIN	Flutes	Enorm 1-STEEL	Flutes
M 2	0.4	45	7	12	2.8	2.1	1.6	.0020	★	2	●	2	●	2	★	2	★	2
M 2.5	0.45	50	9	14	2.8	2.1	2.05	.0025	★	2	●	2	★	2	★	2	★	2
M 3	0.5	56	11	18	3.5	2.7	2.5	.0030	★	3	●	2	●	3	★	3	★	3
M 3.5	0.6	56	12	20	4	3	2.9	.0035	★	3	●	3	●	3	★	3	★	3
M 4	0.7	63	13	21	4.5	3.4	3.3	.0040	★	3	●	3	●	3	★	3	★	3
M 4.5	0.75	70	14	25	6	4.9	3.7	.0045	★	3	●	3	●	3	★	3	★	3
M 5	0.8	70	15	25	6	4.9	4.2	.0050	★	3	●	3	●	3	★	3	★	3
M 6	1	80	17	30	6	4.9	5	.0060	★	3	●	3	●	3	★	3	★	3
M 8	1.25	90	20	35	8	6.2	6.8	.0080	★	3	●	3	●	3	★	3	★	3
M 10	1.5	100	22	39	10	8	8.5	.0100	★	3	●	3	●	3	★	3	★	3

Reduced Shank

Nominal Size ø d ₁	P	mm					□	Tool Identification	C0208950		C0461400		C0501000		C0501400		C0501020	
		l ₁	l ₂	l ₃	ø d ₂	□			Rekord 2B-STEEL-L LH	Flutes	Rekord 2D-STEEL/E TIN	Flutes	Enorm 2-STEEL	Flutes	Enorm 2-STEEL TIN	Flutes	Enorm 2-STEEL	Flutes
M 12	1.75	110	24	—	9	7	10.2	.0112	★	3	●	3	●	3	★	3	★	3
M 14	2	110	26	—	11	9	12	.0114	★	3	●	3	●	3	★	3	★	3
M 16	2	110	27	—	12	9	14	.0116	★	3	●	3	●	3	★	3	★	3
M 18	2.5	125	30	—	14	11	15.5	.0118	★	3	●	3	●	3	★	3	★	3
M 20	2.5	140	32	—	16	12	17.5	.0120	★	3	●	3	●	3	★	3	★	3
M 22	2.5	140	32	—	18	14.5	19.5	.0122	★	3	●	3	●	4	★	4	★	4
M 24	3	160	34	—	18	14.5	21	.0124	★	3	●	3	●	4	★	4	★	4
M 27	3	160	36	—	20	16	24	.0127	★	3	●	3	★	4	★	4	★	4
M 30	3.5	180	40	—	22	18	26.5	.0130	★	3	●	3	●	4	★	4	★	4
M 33	3.5	180	40	—	25	20	29.5	.0133	★	3	●	3	●	4	★	4	★	4
M 36	4	200	50	—	28	22	32	.0136	★	3	●	3	●	4	★	4	★	4
M 42	4.5	200	56	—	32	24	37.5	.0142	★	3	●	3	★	5	★	4	★	4
M 45	4.5	220	58	—	36	29	40.5	.0145	★	3	●	3	★	5	★	4	★	4
M 48	5	250	65	—	36	29	43	.0148	★	3	●	3	★	5	★	4	★	4
M 52	5	250	65	—	40	32	47	.0152	★	3	●	3	★	6	★	4	★	4

STEEL Steel Materials				VA Stainless Steel Materials			Class of Fit Coating Cutting Material Technical Characteristics
							
ISO 3/6G TIN HSS Extra R35 C / 2-3 E / O	7G HSS Extra R35 C / 2-3 E / O	7G TIN HSS Extra R35 C / 2-3 E / O	ISO 2/6H HSS Extra LH, L35 C / 2-3 E / O	ISO 2/6H GLT-1 HSS Extra B / 4-5 E / O / P	ISO 3/6G NT HSS Extra B / 4-5 E / O / P	7G NT HSS Extra B / 4-5 E / O / P	

max. 2.5 x d ₁ 				max. 3 x d ₁ 			Thread Depth and Hole Shape
--	--	--	--	---	--	--	-----------------------------

P 1.1-4.1 K 2.1 N 2.2	P 1.1-3.1 N 2.2	P 1.1-4.1 K 2.1 N 2.2	P 1.1-3.1 N 2.2	P 1.1-4.1 M 1.1-3.1 K 2.1 N 2.2	P 1.1-3.1 M 1.1-2.1 K 2.1 N 2.2, 2.5-6	P 1.1-3.1 M 1.1-2.1 K 2.1 N 2.2, 2.5-6	Applications – Material
-----------------------------	--------------------	-----------------------------	--------------------	--	---	---	-------------------------

B0501420						B0501030		B0501430		B0501050		B020C300			B0203020		B0203030		Tool Identification				
Enorm 1-STEEL TIN		Flutes	Enorm 1-STEEL		Flutes	Enorm 1-STEEL TIN		Flutes	Enorm 1-STEEL-LH		Flutes	Rekord 1B-VA GLT-1		Flutes	Rekord 1B-VA NT		Flutes	Rekord 1B-VA NT		Flutes	Dimens. ID	Nominal Size ø d ₁	P
★	2		★	2		★	2		★	2		★	2		●	2		★	2				
★	2	★	2	★	2	★	2	★	2	●	2	★	2	★	2	★	2	.0025	M 2.5	0.45			
★	3	★	3	★	3	★	3	★	3	●	3	★	3	★	3	★	3	.0030	M 3	0.5			
★	3	★	3	★	3	★	3	★	3	●	3	★	3	★	3	★	3	.0035	M 3.5	0.6			
★	3	★	3	★	3	★	3	★	3	●	3	★	3	★	3	★	3	.0040	M 4	0.7			
★	3	★	3	★	3	★	3	★	3	●	3	★	3	★	3	★	3	.0045	M 4.5	0.75			
★	3	★	3	★	3	★	3	★	3	●	3	★	3	★	3	★	3	.0050	M 5	0.8			
★	3	★	3	★	3	★	3	★	3	●	3	★	3	★	3	★	3	.0060	M 6	1			
★	3	★	3	★	3	★	3	★	3	●	3	★	3	★	3	★	3	.0080	M 8	1.25			
★	3	★	3	★	3	★	3	★	3	●	3	★	3	★	3	★	3	.0100	M 10	1.5			

C0501420						C0501030		C0501430		C0501050		C020C300			C0203020		C0203030		Tool Identification				
Enorm 2-STEEL TIN		Flutes	Enorm 2-STEEL		Flutes	Enorm 2-STEEL TIN		Flutes	Enorm 2-STEEL-LH		Flutes	Rekord 2B-VA GLT-1		Flutes	Rekord 2B-VA NT		Flutes	Rekord 2B-VA NT		Flutes	Dimens. ID	Nominal Size ø d ₁	P
★	3		★	3		★	3		★	3		★	3		●	3		★	3				
★	3	★	3	★	3	★	3	★	3	●	3	★	3	★	3	★	3	.0114	M 14	2			
★	3	★	3	★	3	★	3	★	3	●	3	★	3	★	3	★	3	.0116	M 16	2			
★	3	★	3	★	3	★	3	★	3	●	3	★	3	★	3	★	3	.0118	M 18	2.5			
★	3	★	3	★	3	★	3	★	3	●	3	★	3	★	3	★	3	.0120	M 20	2.5			
★	4	★	4	★	4	★	4	★	4	●	3	★	3	★	3	★	3	.0122	M 22	2.5			
										●	3							.0124	M 24	3			
										●	3							.0127	M 27	3			
										●	4							.0130	M 30	3.5			
										●	4							.0133	M 33	3.5			
										●	4							.0136	M 36	4			
										●	4							.0142	M 42	4.5			
										●	4							.0145	M 45	4.5			
										●	4							.0148	M 48	5			
										●	4							.0152	M 52	5			

● = In stock
★ = Allow 7 days for delivery

- Product Finder
- V_c
- UNC
- UNF
- UNEF
- UN-8
- M**
- MF
- NPSM/NPSC
- NPSF
- Rp (BSPP)
- G
- NPT
- NPTF
- Rc (BSPT)
- STI
- SELF-LOCK
- Accessories
- Tech. Info

DIN Length • DIN Shank

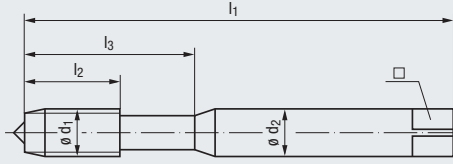

Reinforced Shank
(M2 - M10)

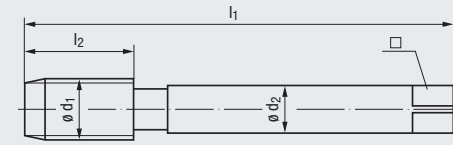

Reduced Shank
(M12 - M52)

M

**ISO Metric Coarse Thread
DIN 13**

Class of Fit

Coating

Cutting Material

Technical Characteristics



Thread Depth
and Hole Shape

Applications – Material

VA
Stainless Steel
Materials



GJV
Cast Iron
Vermicular



ISO 2/6H	ISO 2/6H	ISO 2/6H	6HX
NE2	GLT-1		TICN
HSS Extra	HSS Extra	HSS Extra	HSSE-PM
R35	R35	R35	C / 2-3
C / 2-3	C / 2-3	C / 2-3	E
E / O / P	E / O / P	E / O / P	

max. 2.5 x d₁



max. 2 x d₁

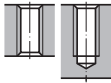

P 1.1-3.1	P 1.1-3.1	P 1.1-4.1	K 1.1-4.2
M 1.1-2.1	M 1.1-2.1	M 1.1-3.1	
K 2.1	K 2.1	K 2.1	

Reinforced Shank

Nominal Size ø d ₁	P	mm			ø d ₂	□	Tool Identification	B0503000		B0503200		B050C300		B010R501	
		l ₁	l ₂	l ₃				Enorm 1-VA	Flutes	Enorm 1-VA NE2	Flutes	Enorm 1-VA GLT-1	Flutes	Rekord 1A-GJV PM-TICN	Flutes
M 2	0.4	45	7	12	2.8	2.1	1.6	.0020	★	2	●	2	★	2	
M 2.5	0.45	50	9	14	2.8	2.1	2.05	.0025	★	2	★	2	★	2	
M 3	0.5	56	11	18	3.5	2.7	2.5	.0030	★	3	●	3	★	3	
M 3.5	0.6	56	12	20	4	3	2.9	.0035	★	3	●	3			
M 4	0.7	63	13	21	4.5	3.4	3.3	.0040	★	3	●	3	★	3	★
M 4.5	0.75	70	14	25	6	4.9	3.7	.0045							
M 5	0.8	70	15	25	6	4.9	4.2	.0050	★	3	●	3	★	3	★
M 6	1	80	17	30	6	4.9	5	.0060	★	3	●	3	★	3	★
M 8	1.25	90	20	35	8	6.2	6.8	.0080	★	3	●	3	★	3	★
M 10	1.5	100	22	39	10	8	8.5	.0100	★	3	●	3	★	3	★

Reduced Shank

Nominal Size ø d ₁	P	mm			ø d ₂	□	Tool Identification	C0503000		C0503200		C010R501		
		l ₁	l ₂	l ₃				Enorm 2-VA	Flutes	Enorm 2-VA NE2	Flutes	Rekord 2A-GJV PM-TICN	Flutes	
M 12	1.75	110	24	—	9	7	10.2	.0112	★	3	●	3	★	4
M 14	2	110	26	—	11	9	12	.0114	★	3	●	3		
M 16	2	110	27	—	12	9	14	.0116	★	3	●	3	★	4
M 18	2.5	125	30	—	14	11	15.5	.0118	★	3	●	3		
M 20	2.5	140	32	—	16	12	17.5	.0120	★	3	●	3		
M 22	2.5	140	32	—	18	14.5	19.5	.0122	★	4	●	4		
M 24	3	160	34	—	18	14.5	21	.0124	★	4	●	4		
M 27	3	160	36	—	20	16	24	.0127	★	4	●	4		
M 30	3.5	180	40	—	22	18	26.5	.0130	★	4	●	4		
M 33	3.5	180	40	—	25	20	29.5	.0133						
M 36	4	200	50	—	28	22	32	.0136						
M 42	4.5	200	56	—	32	24	37.5	.0142						
M 45	4.5	220	58	—	36	29	40.5	.0145						
M 48	5	250	65	—	36	29	43	.0148						
M 52	5	250	65	—	40	32	47	.0152						

GJV Cast Iron Vermicular					AL Aluminum Wrought Alloys	
	new 			new 		
6HX	6HX	6HX	6HX	6HX	ISO 2/6H	ISO 2/6H
TICN	TICN	TICN	TICN	TICN	GLT-8	GLT-8
HSSE-PM	HSSE-PM	HSSE-PM	HSSE-PM	HSSE-PM	HSS Extra	HSS Extra
C / 2-3	C / 2-3	E / 1.5-2	E / 1.5-2	E / 1.5-2	B / approx. 3	R45
E	E	E	E	E	E / 0	C / 2-3
max. 2 x d ₁	max. 2 x d ₁	max. 2 x d ₁	max. 2 x d ₁	max. 2 x d ₁	max. 3 x d ₁	max. 2.5 x d ₁
K 1.1-4.2	K 1.1-4.2	K 1.1-4.2	K 1.1-4.2	K 1.1-4.2	N 1.1-4	N 1.1-4
Class of Fit					Coating	
Technical Characteristics						
Thread Depth and Hole Shape					Applications – Material	

Product Finder

- Vc
- UNC
- UNF
- UNEF
- UN-8
- M**
- MF
- NPSM/NPSC
- NPSF
- Rp (BSPP)
- G
- NPT
- NPTF
- Rc (BSPT)
- STI
- SELF-LOCK
- Accessories
- Tech. Info



B195R501	B106R501	B011R501	B196R501	B109R501	B020S800	B050S800	Tool Identification		
Rekord 1A-GJV IKZ-PM TICN	Rekord 1A-GJV IKZN-PM TICN	Rekord 1A-GJV/E PM-TICN	Rekord 1A-GJV/E IKZ-PM TICN	Rekord 1A-GJV/E IKZN-PM TICN	Rekord 1B-AL GLT-8	Enorm 1-AL GLT-8	Dimens. ID	Nominal Size ø d ₁	P
	upon			upon	★ 2	★ 2	.0020	M 2	0.4
	request			request	★ 2	★ 2	.0025	M 2.5	0.45
		★ 3			★ 2	★ 2	.0030	M 3	0.5
					★ 2	★ 2	.0035	M 3.5	0.6
★ 3			★ 3		★ 2	★ 2	.0040	M 4	0.7
★ 4			★ 4		★ 2	★ 2	.0045	M 4.5	0.75
★ 4			★ 4		★ 2	★ 2	.0050	M 5	0.8
★ 4			★ 4		★ 2	★ 2	.0060	M 6	1
					★ 2	★ 2	.0080	M 8	1.25
					★ 2	★ 2	.0100	M 10	1.5

C195R501	C106R501	C011R501	C196R501	C109R501	C020S800	C050S800	Tool Identification		
Rekord 2A-GJV IKZ-PM TICN	Rekord 2A-GJV IKZN-PM TICN	Rekord 2A-GJV/E PM-TICN	Rekord 2A-GJV/E IKZ-PM TICN	Rekord 2A-GJV/E IKZN-PM TICN	Rekord 2B-AL GLT-8	Enorm 2-AL GLT-8	Dimens. ID	Nominal Size ø d ₁	P
★ 4	upon	★ 4	★ 4	upon	★ 3	★ 3	.0112	M 12	1.75
★ 4	request	★ 4	★ 4	request	★ 3	★ 3	.0114	M 14	2
							.0116	M 16	2
							.0118	M 18	2.5
							.0120	M 20	2.5
							.0122	M 22	2.5
							.0124	M 24	3
							.0127	M 27	3
							.0130	M 30	3.5
							.0133	M 33	3.5
							.0136	M 36	4
							.0142	M 42	4.5
							.0145	M 45	4.5
							.0148	M 48	5
							.0152	M 52	5

● = In stock
★ = Allow 7 days for delivery

1) Threading in through holes is possible only with external cooling/lubrication

- Product Finder
- V_c
- UNC
- UNF
- UNEF
- UN-8
- M**
- MF
- NPSM/NPSC
- NPSF
- Rp (BSPP)
- G
- NPT
- NPTF
- Rc (BSPT)
- STI
- SELF-LOCK
- Accessories
- Tech. Info

DIN Length • DIN Shank

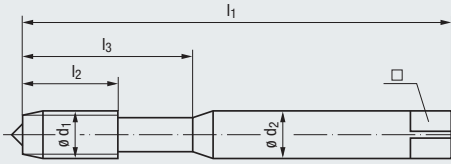

Reinforced Shank (M2 - M10)

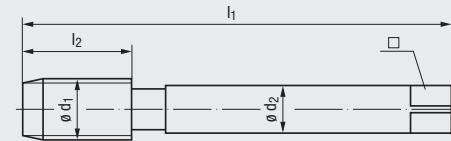

Reduced Shank (M12 - M52)

M

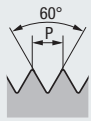

ISO Metric Coarse Thread DIN 13

Class of Fit
Coating
Cutting Material
Technical Characteristics



Thread Depth and Hole Shape

Applications – Material

AL
Aluminum
Wrought Alloys

new



GAL
Aluminum
Cast Alloys



ISO 2/6H
GLT-8
HSS Extra
R45
E / 1.5-2
E / O

6HX
TiCN
HSS Extra
E / 1.5-2
E / M

6HX
TiCN
HSS Extra
E / 1.5-2
E / M

6HX
TiCN
HSS Extra
R15
E / 1.5-2
E / M

max. 2.5 x d₁



max. 2 x d₁

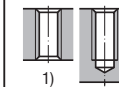

max. 2 x d₁



N 1.1-4

N 1.4-6

N 1.4-6





N 1.4-6





Reinforced Shank

Nominal Size ø d ₁	P	mm					ø d ₂	□	Tool Identification		B051S800		B1969501		B1099501		B0989501		
		l ₁	l ₂	l ₃	l ₃	l ₃			Dimens. ID	Enorm 1-AL/E GLT-8	Flutes	Rekord 1A-GAL/E IKZ-TiCN	Flutes	Rekord 1A-GAL/E IKZN-TiCN	Flutes	Rekord 1D-GAL/E IKZ-TiCN	Flutes		
M 2	0.4	45	7	12	2.8	2.1	1.6	.0020											
M 2.5	0.45	50	9	14	2.8	2.1	2.05	.0025											
M 3	0.5	56	11	18	3.5	2.7	2.5	.0030	★	2									
M 3.5	0.6	56	12	20	4	3	2.9	.0035											
M 4	0.7	63	13	21	4.5	3.4	3.3	.0040	★	2									
M 4.5	0.75	70	14	25	6	4.9	3.7	.0045			★	3				★	3		
M 5	0.8	70	15	25	6	4.9	4.2	.0050	★	2			★	3			★	3	
M 6	1	80	17	30	6	4.9	5	.0060	★	2			★	3	★	3		★	3
M 8	1.25	90	20	35	8	6.2	6.8	.0080	★	2			★	3	★	3		★	3
M 10	1.5	100	22	39	10	8	8.5	.0100	★	2			★	3	★	3		★	3

Reduced Shank

Nominal Size ø d ₁	P	mm					ø d ₂	□	Tool Identification									
		l ₁	l ₂	l ₃	l ₃	l ₃			Dimens. ID									
M 12	1.75	110	24	—	9	7	10.2	.0112										
M 14	2	110	26	—	11	9	12	.0114										
M 16	2	110	27	—	12	9	14	.0116										
M 18	2.5	125	30	—	14	11	15.5	.0118										
M 20	2.5	140	32	—	16	12	17.5	.0120										
M 22	2.5	140	32	—	18	14.5	19.5	.0122										
M 24	3	160	34	—	18	14.5	21	.0124										
M 27	3	160	36	—	20	16	24	.0127										
M 30	3.5	180	40	—	22	18	26.5	.0130										
M 33	3.5	180	40	—	25	20	29.5	.0133										
M 36	4	200	50	—	28	22	32	.0136										
M 42	4.5	200	56	—	32	24	37.5	.0142										
M 45	4.5	220	58	—	36	29	40.5	.0145										
M 48	5	250	65	—	36	29	43	.0148										
M 52	5	250	65	—	40	32	47	.0152										

<p>GAL Aluminum Cast Alloys</p>  <p>new</p>	<p>PVC Long-Chipping Synthetics</p> 	<p>TI Titanium</p> 				
<p>6HX TICN Carbide R15 E / 1.5-2 E / M</p>	<p>6HX CRN HSS Extra R15 E / 1.5-2 E</p>	<p>6HX NT2 HSS Extra L15 D / 4-5 E / O / P</p>	<p>6HX TICN HSS Extra L15 D / 4-5 E / O / P</p>	<p>6HX NT2 HSS Extra R15 C / 2-3 E / O / P</p>	<p>6HX TICN HSS Extra R15 C / 2-3 E / O / P</p>	<p>Class of Fit Coating Cutting Material Technical Characteristics</p> 

<p>max. 2 x d₁</p> 	<p>max. 2 x d₁</p> 	<p>max. 3 x d₁</p> 		<p>max. 2 x d₁</p> 		<p>Thread Depth and Hole Shape</p>
---	---	---	--	---	--	------------------------------------

<p>N 1.4-6</p>	<p>N 4.2</p>	<p>P 4.1-5.1 M 3.1-4.1 N 2.4-5, 2.7 S 1.1-2.2, 2.4</p>		<p>P 4.1-5.1 M 3.1-4.1 N 2.4-5, 2.7 S 1.1-2.2, 2.4</p>		<p>Applications – Material</p>	
-----------------------	---------------------	--	--	--	--	--------------------------------	--

B098Q801		B046L801		B0306001		B0309601		B0456001		B0459601		Tool Identification		
VHM Rekord 1D-GAL/E IKZ-TICN	Flutes	Rekord 1D-PVC/E CRN	Flutes	Rekord 1C-TI NT2	Flutes	Rekord 1C-TI TICN	Flutes	Rekord 1D-TI NT2	Flutes	Rekord 1D-TI TICN	Flutes	Dimens. ID	Nominal Size ø d ₁	P
				★	2	★	2	★	2	★	2	.0020	M 2	0.4
				★	2	★	2	★	2	★	2	.0025	M 2.5	0.45
		★	2	●	2	★	2	●	2	★	2	.0030	M 3	0.5
								●	3			.0035	M 3.5	0.6
★	3	★	3	●	3	★	3	●	3	★	3	.0040	M 4	0.7
												.0045	M 4.5	0.75
★	3	★	3	●	3	★	3	●	3	★	3	.0050	M 5	0.8
★	3	★	3	●	3	★	3	●	3	★	3	.0060	M 6	1
★	3	★	3	●	3	★	3	●	3	★	3	.0080	M 8	1.25
★	3	★	3	●	3	★	3	●	3	★	3	.0100	M 10	1.5

				C0306001		C0309601		C0456001		C0459601		Tool Identification		
				Rekord 2C-TI NT2	Flutes	Rekord 2C-TI TICN	Flutes	Rekord 2D-TI NT2	Flutes	Rekord 2D-TI TICN	Flutes	Dimens. ID	Nominal Size ø d ₁	P
				●	3	★	3	●	3	★	3	.0112	M 12	1.75
												.0114	M 14	2
				●	3	★	3	●	3	★	3	.0116	M 16	2
												.0118	M 18	2.5
				●	3	★	3	●	3	★	3	.0120	M 20	2.5
												.0122	M 22	2.5
				●	3	★	3	●	3	★	3	.0124	M 24	3
												.0127	M 27	3
												.0130	M 30	3.5
												.0133	M 33	3.5
												.0136	M 36	4
												.0142	M 42	4.5
												.0145	M 45	4.5
												.0148	M 48	5
												.0152	M 52	5

● = In stock
★ = Allow 7 days for delivery

Product Finder

- V_c
- UNC
- UNF
- UNEF
- UN-8
- M**
- MF
- NPSM/NPSC
- NPSF
- R_p (BSP)
- G
- NPT
- NPTF
- R_c (BSPT)
- STI
- SELF-LOCK
- Accessories
- Tech. Info



- Product Finder
- V_c
- UNC
- UNF
- UNEF
- UN-8
- M**
- MF
- NPSM/NPSC
- NPSF
- Rp (BSPP)
- G
- NPT
- NPTF
- Rc (BSPT)
- STI
- SELF-LOCK
- Accessories
- Tech. Info

DIN Length • DIN Shank

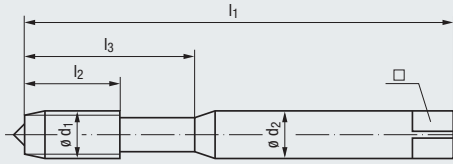

Reinforced Shank
(M2 - M10)

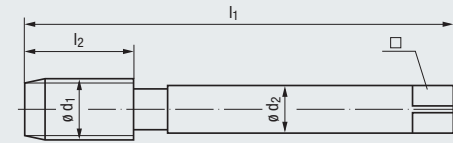

Reduced Shank
(M12 - M52)

TILEG
Titanium
Alloys



NI
Nickel
Alloys



M

**ISO Metric Coarse Thread
DIN 13**

Class of Fit
Coating
Cutting Material
Technical Characteristics



Thread Depth
and Hole Shape

Applications – Material

- 6HX
- TICN
- HSS Extra
- R15
- C / 2-3
- E / O / P



- M 4.1
- S 1.2-3

- 6HX
- TICN
- HSSE-PM**
- L08
- D / 4-5
- O / P



- M 4.1
- N 2.8
- S 1.2-3
- S 2.3, 2.5-6

- 6HX
- TICN
- HSSE-PM**
- R10
- C / 2-3
- O / P



- M 4.1
- N 2.8
- S 1.2-3
- S 2.3, 2.5-6

Reinforced Shank

Nominal Size ø d ₁	P	mm					ø d ₂	□	Tool Identification		B040V401		B030J401		B438J401	
		l ₁	l ₂	l ₃	l ₄	l ₅			Rekord 1DF-TILEG TICN	Flutes	Rekord 1C-NI-PM TICN	Flutes	Rekord 1DF-NI-PM TICN	Flutes		
M 2	0.4	45	7	12	2.8	2.1	1.6	.0020								
M 2.5	0.45	50	9	14	2.8	2.1	2.05	.0025								
M 3	0.5	56	11	18	3.5	2.7	2.5	.0030	★	2		★	2	★	2	
M 3.5	0.6	56	12	20	4	3	2.9	.0035								
M 4	0.7	63	13	21	4.5	3.4	3.3	.0040	★	3		★	3	★	3	
M 4.5	0.75	70	14	25	6	4.9	3.7	.0045								
M 5	0.8	70	15	25	6	4.9	4.2	.0050	★	3		★	3	★	3	
M 6	1	80	17	30	6	4.9	5	.0060	★	3		★	3	★	3	
M 8	1.25	90	20	35	8	6.2	6.8	.0080	★	3		★	3	★	3	
M 10	1.5	100	22	39	10	8	8.5	.0100	★	3		★	3	★	3	

Reduced Shank

Nominal Size ø d ₁	P	mm					ø d ₂	□	Tool Identification		C030J401		C438J401	
		l ₁	l ₂	l ₃	l ₄	l ₅			Rekord 2C-NI-PM TICN	Flutes	Rekord 2DF-NI-PM TICN	Flutes		
M 12	1.75	110	24	—	9	7	10.2	.0112			★	3	★	3
M 14	2	110	26	—	11	9	12	.0114			★	3	★	3
M 16	2	110	27	—	12	9	14	.0116			★	3	★	3
M 18	2.5	125	30	—	14	11	15.5	.0118						
M 20	2.5	140	32	—	16	12	17.5	.0120			★	3	★	3
M 22	2.5	140	32	—	18	14.5	19.5	.0122						
M 24	3	160	34	—	18	14.5	21	.0124						
M 27	3	160	36	—	20	16	24	.0127						
M 30	3.5	180	40	—	22	18	26.5	.0130						
M 33	3.5	180	40	—	25	20	29.5	.0133						
M 36	4	200	50	—	28	22	32	.0136						
M 42	4.5	200	56	—	32	24	37.5	.0142						
M 45	4.5	220	58	—	36	29	40.5	.0145						
M 48	5	250	65	—	36	29	43	.0148						
M 52	5	250	65	—	40	32	47	.0152						

H
Materials of High Tensile Strength



6HX	6HX	6HX	6HX	6HX
NT	TICN	TICN	TICN	Carbide
HSS Extra	HSS Extra	HSS Extra	HSS Extra	
C / 2-3	C / 2-3	C / 2-3	C / 2-3	C / 2-3
E / O / P	E / O / P	E / O	E / O	E / O

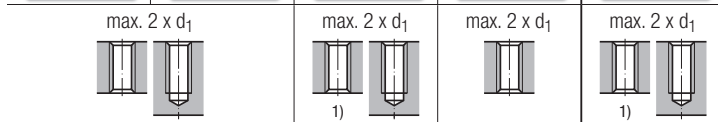

P 1.1-3.1	P 1.1-4.1	P 1.1-4.1	P 1.1-4.1	P 5.1
K 1.1-4.2	K 1.1-4.2	K 1.1-4.2	K 1.1-4.2	K 1.1-4.2
N 2.4-7	N 2.4-7	N 2.4-7	N 2.4-7	N 1.5-6, 2.6-8
N 4.1, 5.1	N 4.1, 5.1	N 4.1, 5.1	N 4.1, 5.1	N 4.1, 4.3-5.2
				H 1.1-2

B0100501		B0109101		B1959101		B1069101		B1950901		Tool Identification		
Rekord 1A-H NT	Flutes	Rekord 1A-H TICN	Flutes	Rekord 1A-H-IKZ TICN	Flutes	Rekord 1A-H-IKZN TICN	Flutes	VHM Rekord 1A-H-IKZ	Flutes	Dimens. ID	Nominal Size ø d ₁	P
★	3	★	3							.0020	M 2	0.4
★	3	★	3			upon				.0025	M 2.5	0.45
●	3	★	3					★	3	.0030	M 3	0.5
●	3	★	3			request		★	3	.0035	M 3.5	0.6
●	3	★	3					★	3	.0040	M 4	0.7
●	3	★	3	★	3			★	3	.0045	M 4.5	0.75
●	3	●	3	★	3			●	3	.0050	M 5	0.8
●	3	●	3	★	3			●	3	.0060	M 6	1
●	3	●	3	★	3			●	3	.0080	M 8	1.25
●	3	★	3	★	3			●	3	.0100	M 10	1.5

C0100501		C0109101		C1959101		C1069101		C1950901		Tool Identification		
Rekord 2A-H NT	Flutes	Rekord 2A-H TICN	Flutes	Rekord 2A-H-IKZ TICN	Flutes	Rekord 2A-H-IKZN TICN	Flutes	KHM Rekord 2A-H-IKZ	Flutes	Dimens. ID	Nominal Size ø d ₁	P
●	3	★	3	★	3			●	3	.0112	M 12	1.75
●	3	★	3	★	3	upon		★	4	.0114	M 14	2
●	3	★	3	★	3			★	4	.0116	M 16	2
						request		★	4	.0118	M 18	2.5
●	4	★	4	★	4			★	4	.0120	M 20	2.5
								★	4	.0122	M 22	2.5
●	4	★	4					★	4	.0124	M 24	3
								★	4	.0127	M 27	3
										.0130	M 30	3.5
										.0133	M 33	3.5
										.0136	M 36	4
										.0142	M 42	4.5
										.0145	M 45	4.5
										.0148	M 48	5
										.0152	M 52	5

● = In stock
★ = Allow 7 days for delivery

1) Threading in through holes is possible only with external cooling/lubrication

Product Finder

V_c

UNC

UNF

UNEF

UN-8

M

MF

NPSM/NPSC

NPSF

R_p (BSPP)

G

NPT

NTF

R_c (BSPT)

STI

SELF-LOCK

Accessories

Tech. Info



- Product Finder
- V_c
- UNC
- UNF
- UNEF
- UN-8
- M**
- MF
- NPSM/NPSC
- NPSF
- Rp (BSPP)
- G
- NPT
- NPTF
- Rc (BSPT)
- STI
- SELF-LOCK
- Accessories
- Tech. Info

DIN Length • DIN Shank

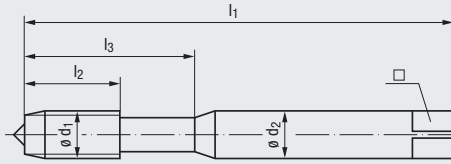

Reinforced Shank
(M4 - M10)

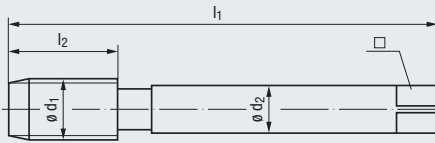

Reduced Shank
(M12 - M20)

HCUT
Hardened
Steels



M

**ISO Metric Coarse Thread
DIN 13**

Class of Fit
Coating
Cutting Material
Technical Characteristics

6HX

TICN

HSSE-PM

C / 2-3

O / P

Thread Depth
and Hole Shape

max. 1.5 x d₁

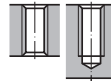

Applications – Material

H 1.1-2

Reinforced Shank

Nominal Size								Tool Identification		B010J901	
Size	P	l ₁	l ₂	l ₃	mm	Ø d ₂	□	Dimens. ID	Rekord 1A-HCUT-PM TICN	Flutes	
M 4	0.7	63	7	21	4.5	3.4	3.4	.0040			
M 5	0.8	70	8	25	6	4.9	4.3	.0050			
M 6	1	80	10	30	6	4.9	5.1	.0060	★	4	
M 8	1.25	90	14	35	8	6.2	6.9	.0080	★	5	
M 10	1.5	100	16	39	10	8	8.6	.0100	★	5	

Reduced Shank

Nominal Size								Tool Identification		C010J901	
Size	P	l ₁	l ₂	l ₃	mm	Ø d ₂	□	Dimens. ID	Rekord 2A-HCUT-PM TICN	Flutes	
M 12	1.75	110	18	—	9	7	10.4	.0112	★	5	
M 14	2	110	20	—	11	9	12.2	.0114			
M 16	2	110	22	—	12	9	14.2	.0116	★	6	
M 20	2.5	140	25	—	16	12	17.7	.0120	★	7	

DIN Length • DIN Shank

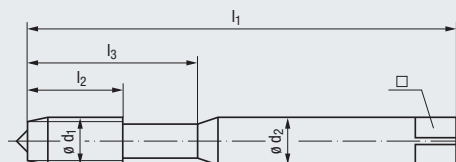

Reinforced Shank

HCUT
Hardened
Steels

2)

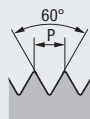
MISO Metric Coarse Thread
DIN 13Class of Fit
Coating
Cutting Material
Technical CharacteristicsThread Depth
and Hole Shape

Applications – Material

6HX	6HX
TICN	TICN
Carbide	Carbide
D / 4-5	C / 2-3
O / P	O / P

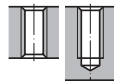
max. 1.5 x d₁

H 1.3-4

Reinforced Shank

Tool Identification

B016K101

B010K101

Nominal Size ø d ₁	P	mm					ø d ₂	□	Tool ID	B016K101		B010K101	
		l ₁	l ₂	l ₃	ø d ₂	□				VHM Rekord 1A-HCUT/D TICN	Flutes	VHM Rekord 1A-HCUT/C TICN	Flutes
M 3	0.5	63	6	18	4.5	3.4	2.55	.0030	★	3	★	3	
M 4	0.7	63	8	20	4.5	3.4	3.4	.0040	★	4	★	4	
M 5	0.8	70	10	26	6	4.9	4.3	.0050	★	4	★	4	
M 6	1	80	12	28	6	4.9	5.1	.0060	★	4	★	4	
M 8	1.25	90	15	35	8	6.2	6.9	.0080	★	5	★	5	
M 10	1.5	100	18	38	10	8	8.6	.0100	★	5	★	5	
M 12	1.75	110	21	41	12	9	10.4	.0112	★	5	★	5	
M 14	2	110	24	44	14	11	12.2	.0114	★	6	★	6	
M 16	2	110	24	44	16	12	14.2	.0116	★	6	★	6	

2) Please note: Use solid carbide tap VHM-Rekord 1A-HCUT/D-TICN as No.1 tap!

Product
FinderV_c

UNC

UNF

UNEF

UN-8

M

MF

NPSM/NPSC

NPSF

Rp (BSPP)

G

NPT

NPTF

Rc (BSPT)

STI

SELF-LOCK

Accessories

Tech. Info



- Product Finder
- V_c
- UNC
- UNF
- UNEF
- UN-8
- M
- MF
- NPSM/NPSC
- NPSF
- Rp (BSPP)
- G
- NPT
- NPTF
- Rc (BSPT)
- STI
- SELF-LOCK
- Accessories
- Tech. Info

DIN Length • DIN Shank

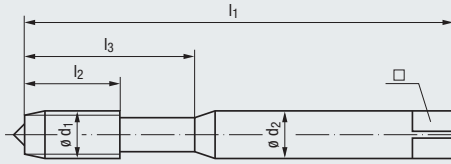

Reinforced Shank
(M2 - M10)

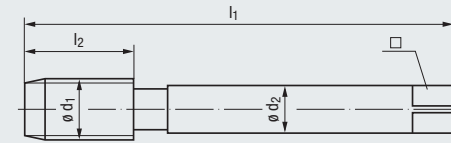

Reduced Shank
(M12 - M52)

M

**ISO Metric Coarse Thread
DIN 13**

Class of Fit
Coating
Cutting Material
Technical Characteristics

Thread Depth
and Hole Shape

Applications – Material

Z
CNC-Controlled
Machines



6HX	6HX	6HX	6HX	6HX
TICN	TICN	TICN	TICN	TICN
HSS Extra	HSS Extra	HSS Extra	HSS Extra	HSS Extra
C / 2-3	C / 2-3	C / 2-3	E / 1.5-2	E / 1.5-2
E / O / P	E / O	E / O	E / O / P	E / O
max. 2 x d ₁	max. 2 x d ₁	max. 2 x d ₁	max. 2 x d ₁	max. 2 x d ₁
P 1.1-4.1 K 1.1-4.2 N 1.4-6, 2.4-7 N 4.1	P 1.1-4.1 K 1.1-4.2 N 1.4-6, 2.4-7 N 4.1	P 1.1-4.1 K 1.1-4.2 N 1.4-6, 2.4-7 N 4.1	P 1.1-4.1 K 1.1-4.2 N 1.4-6, 2.4-7 N 4.1	P 1.1-4.1 K 1.1-4.2 N 1.4-6, 2.4-7 N 4.1

Reinforced Shank

Nominal Size ø d ₁	P	mm			ø d ₂	□	Tool Identification		B0109401		B1959401		B1069401		B0119401		B1969401	
		l ₁	l ₂	l ₃			Rekord 1A-Z TICN	Flutes	Rekord 1A-Z-IKZ TICN	Flutes	Rekord 1A-Z-IKZN TICN	Flutes	Rekord 1A-Z/E TICN	Flutes	Rekord 1A-Z/E-IKZ TICN	Flutes		
M 2	0.4	45	4	12	2.8	2.1	1.6	.0020										
M 2.5	0.45	50	5	14	2.8	2.1	2.05	.0025										
M 3	0.5	56	6	18	3.5	2.7	2.5	.0030	★	3					★	3		
M 3.5	0.6	56	7	20	4	3	2.9	.0035										
M 4	0.7	63	7	21	4.5	3.4	3.3	.0040	★	3	★	3			★	3	★	3
M 4.5	0.75	70	8	25	6	4.9	3.7	.0045										
M 5	0.8	70	8	25	6	4.9	4.2	.0050	★	3	★	3			★	3	★	3
M 6	1	80	10	30	6	4.9	5	.0060	★	3	★	3	★	3	★	3	★	3
M 8	1.25	90	14	35	8	6.2	6.8	.0080	★	3	★	3	★	3	★	3	★	3
M 10	1.5	100	16	39	10	8	8.5	.0100	★	3	★	3	★	3	★	3	★	3

Reduced Shank

Nominal Size ø d ₁	P	mm			ø d ₂	□	Tool Identification		C0109401		C1959401		C0119401		C1969401			
		l ₁	l ₂	l ₃			Rekord 2A-Z TICN	Flutes	Rekord 2A-Z-IKZ TICN	Flutes	Rekord 2A-Z/E TICN	Flutes	Rekord 2A-Z/E-IKZ TICN	Flutes				
M 12	1.75	110	18	—	9	7	10.2	.0112	●	3	★	3			★	3	★	3
M 14	2	110	20	—	11	9	12	.0114	★	3	★	3			★	3	★	3
M 16	2	110	22	—	12	9	14	.0116	★	3	★	3			★	3	★	3
M 18	2.5	125	25	—	14	11	15.5	.0118										
M 20	2.5	140	25	—	16	12	17.5	.0120	★	4	★	4			★	4	★	4
M 22	2.5	140	27	—	18	14.5	19.5	.0122										
M 24	3	160	30	—	18	14.5	21	.0124			★	4						
M 27	3	160	30	—	20	16	24	.0127										
M 30	3.5	180	35	—	22	18	26.5	.0130										
M 33	3.5	180	35	—	25	20	29.5	.0133										
M 36	4	200	40	—	28	22	32	.0136										
M 42	4.5	200	45	—	32	24	37.5	.0142										
M 45	4.5	220	45	—	36	29	40.5	.0145										
M 48	5	250	50	—	36	29	43	.0148										
M 52	5	250	50	—	40	32	47	.0152										

Z
CNC-Controlled
Machines

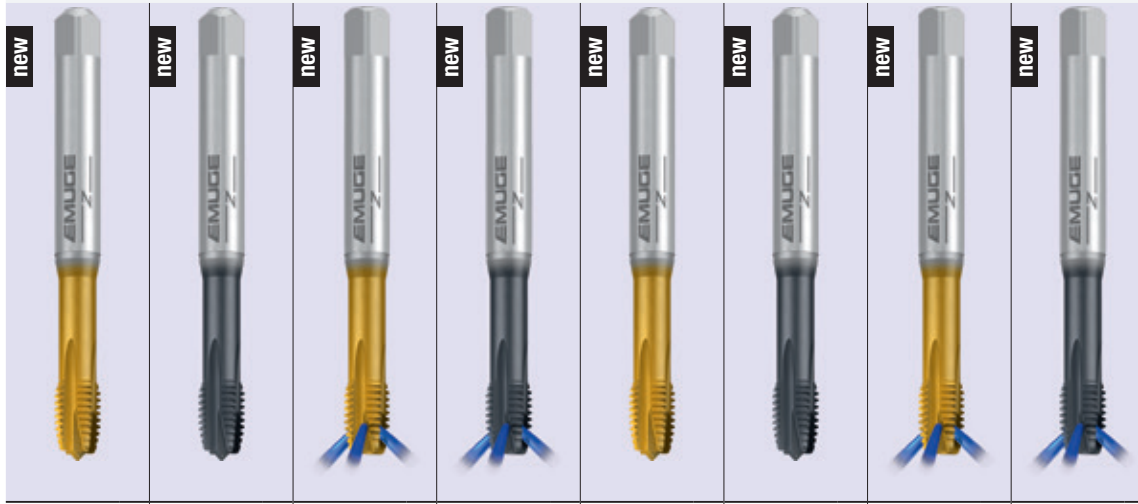

6HX	6HX	6HX	6HX	6GX	6GX	6GX	6GX
TIN-70	GLT-1	TIN-70	GLT-1	TIN-70	GLT-1	TIN-70	GLT-1
HSSE-PM	HSSE-PM	HSSE-PM	HSSE-PM	HSSE-PM	HSSE-PM	HSSE-PM	HSSE-PM
B / 4-5	B / 4-5	B / 4-5	B / 4-5	B / 4-5	B / 4-5	B / 4-5	B / 4-5
E / O / P	E / O / P	E / O	E / O	E / O / P	E / O / P	E / O	E / O

Class of Fit
Coating
Cutting Material
Technical Characteristics

max. 3 x d₁



Thread Depth
and Hole Shape

P 1.1-5.1	P 1.1-5.1	P 1.1-5.1	P 1.1-5.1	P 1.1-5.1	P 1.1-5.1	P 1.1-5.1	P 1.1-5.1
M 1.1-3.1	M 1.1-3.1	M 1.1-3.1	M 1.1-3.1	M 1.1-3.1	M 1.1-3.1	M 1.1-3.1	M 1.1-3.1
K 2.1	K 2.1	K 2.1	K 2.1	K 2.1	K 2.1	K 2.1	K 2.1
N 1.4-2.2, 2.4-5	N 1.4-2.2, 2.4-5	N 1.4-2.2, 2.4-5	N 1.4-2.2, 2.4-5	N 1.4-2.2, 2.4-5	N 1.4-2.2, 2.4-5	N 1.4-2.2, 2.4-5	N 1.4-2.2, 2.4-5
S 1.1	S 1.1	S 1.1	S 1.1	S 1.1	S 1.1	S 1.1	S 1.1

Applications – Material

B0208F01		B020A601		B1088F01		B108A601		B0208F21		B020A621		B1088F21		B108A621		Tool Identification		
Rekord 1B-Z-PM TIN-70	Flutes	Rekord 1B-Z-PM GLT-1	Flutes	Rekord 1B-Z-IKZN PM-TIN-70	Flutes	Rekord 1B-Z-IKZN PM-GLT-1	Flutes	Rekord 1B-Z-PM TIN-70	Flutes	Rekord 1B-Z-PM GLT-1	Flutes	Rekord 1B-Z-IKZN PM-TIN-70	Flutes	Rekord 1B-Z-IKZN PM-GLT-1	Flutes	Dimens. ID	Nominal Size ø d ₁	P
★	2	★	2	upon		upon		★	2	★	2	upon		upon		.0020	M 2	0.4
★	2	★	2					★	2	★	2					.0025	M 2.5	0.45
★	3	★	3					★	3	★	3					.0030	M 3	0.5
★	3	★	3	request		request						request		request		.0035	M 3.5	0.6
★	3	★	3					★	3	★	3					.0040	M 4	0.7
★	3	★	3					★	3	★	3					.0045	M 4.5	0.75
★	3	★	3					★	3	★	3					.0050	M 5	0.8
★	4	★	4					★	4	★	4					.0060	M 6	1
★	4	★	4					★	4	★	4					.0080	M 8	1.25
★	4	★	4					★	4	★	4					.0100	M 10	1.5

C0208F01		C020A601		C1088F01		C108A601		C0208F21		C020A621		C1088F21		C108A621		Tool Identification		
Rekord 2B-Z-PM TIN-70	Flutes	Rekord 2B-Z-PM GLT-1	Flutes	Rekord 2B-Z-IKZN PM-TIN-70	Flutes	Rekord 2B-Z-IKZN PM-GLT-1	Flutes	Rekord 2B-Z-PM TIN-70	Flutes	Rekord 2B-Z-PM GLT-1	Flutes	Rekord 2B-Z-IKZN PM-TIN-70	Flutes	Rekord 2B-Z-IKZN PM-GLT-1	Flutes	Dimens. ID	Nominal Size ø d ₁	P
★	4	★	4	upon		upon		★	4	★	4	upon		upon		.0112	M 12	1.75
★	4	★	4					★	4	★	4					.0114	M 14	2
★	4	★	4	request		request		★	4	★	4	request		request		.0116	M 16	2
★	4	★	4					★	4	★	4					.0118	M 18	2.5
★	4	★	4					★	4	★	4					.0120	M 20	2.5
★	4	★	4					★	4	★	4					.0122	M 22	2.5
★	4	★	4					★	4	★	4					.0124	M 24	3
★	4	★	4					★	4	★	4					.0127	M 27	3
★	4	★	4					★	4	★	4					.0130	M 30	3.5
★	4	★	4					★	4	★	4					.0133	M 33	3.5
★	4	★	4					★	4	★	4					.0136	M 36	4
★	4	★	4					★	4	★	4					.0142	M 42	4.5
★	4	★	4					★	4	★	4					.0145	M 45	4.5
★	4	★	4					★	4	★	4					.0148	M 48	5
★	4	★	4					★	4	★	4					.0152	M 52	5

● = In stock
★ = Allow 7 days for delivery

- Product Finder
- V_c
- UNC
- UNF
- UNEF
- UN-8
- M**
- MF
- NPSM/NPSC
- NPSF
- R_p (BSPP)
- G
- NPT
- NPTF
- R_c (BSPT)
- STI
- SELF-LOCK
- Accessories
- Tech. Info



- Product Finder
- V_c
- UNC
- UNF
- UNEF
- UN-8
- M**
- MF
- NPSM/NPSC
- NPSF
- Rp (BSPP)
- G
- NPT
- NPTF
- Rc (BSPT)
- STI
- SELF-LOCK
- Accessories
- Tech. Info

DIN Length • DIN Shank

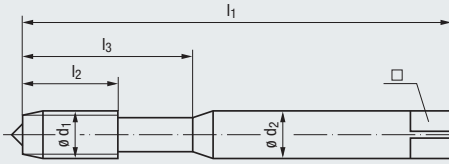

Reinforced Shank
(M2 - M10)

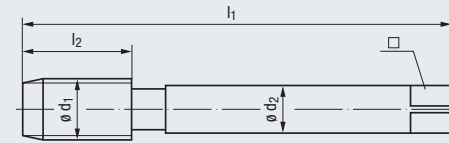

Reduced Shank
(M12 - M52)

M

**ISO Metric Coarse Thread
DIN 13**

Class of Fit
Coating
Cutting Material
Technical Characteristics

Thread Depth
and Hole Shape

Applications – Material

Z
CNC-Controlled
Machines



6HX	6HX	6HX	6HX	ISO 2/6H
TIN	TIN	TIN	TIN	
HSS Extra	HSS Extra	HSS Extra	HSS Extra	HSS Extra
R15	R15	R15	R15	R45
C / 2-3	C / 2-3	C / 2-3	E / 1.5-2	C / 2-3
E / O / P	E / O	E / O	E / O	E / O / P

max. 2 x d₁



max. 3 x d₁



P 2.1-5.1	P 2.1-5.1	P 2.1-5.1	P 2.1-5.1	P 1.1-4.1
K 2.1-2	K 2.1-2	K 2.1-2	K 2.1-2	M 1.1-2.1
N 1.4-6, 2.4-5	N 1.4-6, 2.4-5	N 1.4-6, 2.4-5	N 1.4-6, 2.4-5	N 2.1

Reinforced Shank

Nominal Size ø d ₁	P	mm			ø d ₂	□	Tool Identification		B0453701		B0963701		B4253701		B4053701		B0503500	
		l ₁	l ₂	l ₃			Dimens. ID	Rekord 1D-Z TIN	Flutes	Rekord 1D-Z-IKZ TIN	Flutes	Rekord 1D-Z-BF IKZ-TIN	Flutes	Rekord 1D-Z-E-BF IKZ-TIN	Flutes	Enorm 1-Z	Flutes	
M 2	0.4	45	4	12	2.8	2.1	1.6	.0020										
M 2.5	0.45	50	5	14	2.8	2.1	2.05	.0025										
M 3	0.5	56	6	18	3.5	2.7	2.5	.0030	★	2							★	3
M 3.5	0.6	56	7	20	4	3	2.9	.0035									★	3
M 4	0.7	63	7	21	4.5	3.4	3.3	.0040	★	3	★	3	★	3	★	3	★	3
M 4.5	0.75	70	8	25	6	4.9	3.7	.0045										
M 5	0.8	70	8	25	6	4.9	4.2	.0050	★	3	★	3	★	3	★	3	★	3
M 6	1	80	10	30	6	4.9	5	.0060	★	3	★	3	★	3	★	3	★	3
M 8	1.25	90	14	35	8	6.2	6.8	.0080	★	3	★	3	★	3	★	3	★	3
M 10	1.5	100	16	39	10	8	8.5	.0100	★	3	★	3	★	3	★	3	★	3

Reduced Shank

Nominal Size ø d ₁	P	mm			ø d ₂	□	Tool Identification		C0453701		C0963701		C4253701		C4053701		C0503500	
		l ₁	l ₂	l ₃			Dimens. ID	Rekord 2D-Z TIN	Flutes	Rekord 2D-Z-IKZ TIN	Flutes	Rekord 2D-Z-BF IKZ-TIN	Flutes	Rekord 2D-Z-E-BF IKZ-TIN	Flutes	Enorm 2-Z	Flutes	
M 12	1.75	110	18	—	9	7	10.2	.0112	★	3	★	3	★	3	★	3	★	4
M 14	2	110	20	—	11	9	12	.0114									★	4
M 16	2	110	22	—	12	9	14	.0116	★	3	★	3	★	3	★	3	★	4
M 18	2.5	125	25	—	14	11	15.5	.0118									★	4
M 20	2.5	140	25	—	16	12	17.5	.0120	★	3	★	3	★	3	★	3	★	4
M 22	2.5	140	27	—	18	14.5	19.5	.0122									★	5
M 24	3	160	30	—	18	14.5	21	.0124			★	3					★	5
M 27	3	160	30	—	20	16	24	.0127										
M 30	3.5	180	35	—	22	18	26.5	.0130			★	4						
M 33	3.5	180	35	—	25	20	29.5	.0133										
M 36	4	200	40	—	28	22	32	.0136										
M 42	4.5	200	45	—	32	24	37.5	.0142										
M 45	4.5	220	45	—	36	29	40.5	.0145										
M 48	5	250	50	—	36	29	43	.0148										
M 52	5	250	50	—	40	32	47	.0152										

Z
CNC-Controlled
Machines



ISO 2/6H	ISO 2/6H	ISO 2/6H	ISO 2/6H	ISO 2/6H	ISO 2/6H	ISO 2/6H	ISO 3/6G
TIN	GLT-1	GLT-1		TIN	GLT-1	TIN	TIN
HSS Extra	HSS Extra	HSS Extra	HSS Extra	HSS Extra	HSS Extra	HSS Extra	HSS Extra
R45	R45	R45	R45	R45	R45	R45	R45
C / 2-3	C / 2-3	C / 2-3	E / 1.5-2	E / 1.5-2	E / 1.5-2	E / 1.5-2	E / 1.5-2
E / O / P	E / O / P	E / O	E / O / P	E / O / P	E / O / P	E / O	E / O / P

Class of Fit
Coating
Cutting Material
Technical Characteristics

max. 3 x d₁



Thread Depth and Hole Shape

P 1.1-4.1	P 1.1-4.1	P 1.1-4.1	P 1.1-4.1	P 1.1-4.1	P 1.1-4.1	P 1.1-4.1	P 1.1-4.1
M 1.1-3.1	M 1.1-3.1	M 1.1-3.1	M 1.1-2.1	M 1.1-3.1	M 1.1-3.1	M 1.1-3.1	M 1.1-3.1
N 1.4-6	N 1.4-6	N 1.4-6	N 2.1	N 1.4-6	N 1.4-6	N 1.4-6	N 1.4-6
N 2.1-2, 2.4-5	N 2.1-2, 2.4-5	N 2.1-2, 2.4-5		N 2.1-2, 2.4-5	N 2.1-2, 2.4-5	N 2.1-2, 2.4-5	N 2.1-2, 2.4-5
S 1.1	S 1.1	S 1.1		S 1.1	S 1.1	S 1.1	S 1.1

Applications – Material

B0503700		B050C400		B099C400		B0513500		B0513700		B051C400		B0973700		B0513720		Tool Identification		
Enorm 1-Z TIN	Flutes	Enorm 1-Z GLT-1	Flutes	Enorm 1-Z-IKZ GLT-1	Flutes	Enorm 1-Z/E	Flutes	Enorm 1-Z/E TIN	Flutes	Enorm 1-Z/E GLT-1	Flutes	Enorm 1-Z/E-IKZ TIN	Flutes	Enorm 1-Z/E TIN	Flutes	Dimens. ID	Nominal Size ø d ₁	P
																.0020	M 2	0.4
★	3	★	3			★	3	●	3	★	3			★	3	.0025	M 2.5	0.45
★	3															.0030	M 3	0.5
★	3	★	3			●	3	●	3	★	3			★	3	.0035	M 3.5	0.6
																.0040	M 4	0.7
★	3	★	3	★	3	●	3	●	3	★	3	★	3	★	3	.0045	M 4.5	0.75
★	3	★	3	★	3	★	3	●	3	★	3	●	3	★	3	.0050	M 5	0.8
★	3	★	3	★	3	●	3	●	3	★	3	●	3	★	3	.0060	M 6	1
★	3	★	3	★	3	●	3	●	3	★	3	●	3	★	3	.0080	M 8	1.25
★	3	★	3	★	3	★	3	●	3	★	3	●	3	★	3	.0100	M 10	1.5

C0503700		C050C400		C099C400		C0513500		C0513700		C051C400		C0973700		C0513720		Tool Identification		
Enorm 2-Z TIN	Flutes	Enorm 2-Z GLT-1	Flutes	Enorm 2-Z-IKZ GLT-1	Flutes	Enorm 2-Z/E	Flutes	Enorm 2-Z/E TIN	Flutes	Enorm 2-Z/E GLT-1	Flutes	Enorm 2-Z/E-IKZ TIN	Flutes	Enorm 2-Z/E TIN	Flutes	Dimens. ID	Nominal Size ø d ₁	P
★	4	★	4	★	4	★	4	●	4	★	4	★	4	★	4	.0112	M 12	1.75
						★	4					★	4			.0114	M 14	2
★	4	★	4	★	4	★	4	●	4	★	4	★	4	★	4	.0116	M 16	2
						★	4									.0118	M 18	2.5
★	4	★	4	★	4	★	4	★	4	★	4	★	4	★	4	.0120	M 20	2.5
						★	5									.0122	M 22	2.5
★	5	★	5			★	5	★	5							.0124	M 24	3
																.0127	M 27	3
																.0130	M 30	3.5
																.0133	M 33	3.5
																.0136	M 36	4
																.0142	M 42	4.5
																.0145	M 45	4.5
																.0148	M 48	5
																.0152	M 52	5

● = In stock
★ = Allow 7 days for delivery

- Product Finder
- V_c
- UNC
- UNF
- UNEF
- UN-8
- M**
- MF
- NPSM/NPSC
- NPSF
- R_p (BSPP)
- G
- NPT
- NPTF
- R_c (BSPT)
- STI
- SELF-LOCK
- Accessories
- Tech. Info



- Product Finder
- V_c
- UNC
- UNF
- UNEF
- UN-8
- M**
- MF
- NPSM/NPSC
- NPSF
- Rp (BSPP)
- G
- NPT
- NPTF
- Rc (BSPT)
- STI
- SELF-LOCK
- Accessories
- Tech. Info

DIN Length • DIN Shank

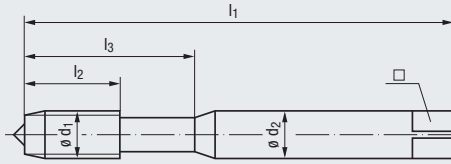

Reinforced Shank
(M2 - M10)

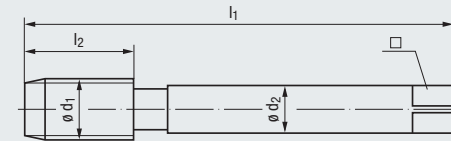

Reduced Shank
(M12 - M52)

SPEED High-Speed Cutting



M

**ISO Metric Coarse Thread
DIN 13**

Class of Fit
Coating
Cutting Material
Technical Characteristics



Thread Depth
and Hole Shape

Applications – Material

6HX	6HX	6HX	6HX
TICN	TICN	TICN	TICN
HSS Extra	HSS Extra	HSS Extra	HSS Extra
C / 2-3	C / 2-3	E / 1.5-2	E / 1.5-2
E	E	E	E
max. 2 x d ₁	max. 2 x d ₁	max. 2 x d ₁	max. 2 x d ₁
K 1.1-4.2	K 1.1-4.2	K 1.1-4.2	K 1.1-4.2
N 1.4-6	N 1.4-6	N 1.4-6	N 1.4-6

Reinforced Shank

Nominal Size ø d ₁	P	mm					ø d ₂	□	Tool Identification		B3159401		B3179401		B3169401		B3189401	
		l ₁	l ₂	l ₃	□	□			Rekord 1A-SPEED IKZ-TICN	Flutes	Rekord 1A-SPEED IKZN-TICN	Flutes	Rekord 1A-SPEED/E IKZ-TICN	Flutes	Rekord 1A-SPEED/E IKZN-TICN	Flutes		
M 2	0.4	45	4	12	2.8	2.1	1.6	.0020										
M 2.5	0.45	50	5	14	2.8	2.1	2.05	.0025			upon							
M 3	0.5	56	6	18	3.5	2.7	2.5	.0030										
M 3.5	0.6	56	7	20	4	3	2.9	.0035										
M 4	0.7	63	7	21	4.5	3.4	3.3	.0040	★	3	request			★	3			
M 4.5	0.75	70	8	25	6	4.9	3.7	.0045										
M 5	0.8	70	8	25	6	4.9	4.2	.0050	●	3			★	3				
M 6	1	80	10	30	6	4.9	5	.0060	●	3			★	3	★	3		
M 8	1.25	90	14	35	8	6.2	6.8	.0080	●	3			★	3	★	3	★	3
M 10	1.5	100	16	39	10	8	8.5	.0100	●	3			★	3	★	3	★	3

Reduced Shank

Nominal Size ø d ₁	P	mm					ø d ₂	□	Tool Identification		C3159401		C3169401	
		l ₁	l ₂	l ₃	□	□			Rekord 2A-SPEED IKZ-TICN	Flutes	Rekord 2A-SPEED/E IKZ-TICN	Flutes		
M 12	1.75	110	18	—	9	7	10.2	.0112	●	3			★	3
M 14	2	110	20	—	11	9	12	.0114	★	3			★	3
M 16	2	110	22	—	12	9	14	.0116	●	3			★	3
M 18	2.5	125	25	—	14	11	15.5	.0118						
M 20	2.5	140	25	—	16	12	17.5	.0120	●	4			★	4
M 22	2.5	140	27	—	18	14.5	19.5	.0122						
M 24	3	160	30	—	18	14.5	21	.0124						
M 27	3	160	30	—	20	16	24	.0127						
M 30	3.5	180	35	—	22	18	26.5	.0130						
M 33	3.5	180	35	—	25	20	29.5	.0133						
M 36	4	200	40	—	28	22	32	.0136						
M 42	4.5	200	45	—	32	24	37.5	.0142						
M 45	4.5	220	45	—	36	29	40.5	.0145						
M 48	5	250	50	—	36	29	43	.0148						
M 52	5	250	50	—	40	32	47	.0152						

DIN Length • DIN Shank

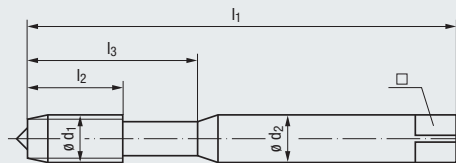

Reinforced Shank
(M2 - M10)

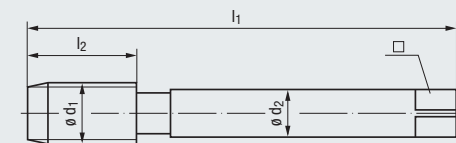

Reduced Shank
(M12 - M52)

M

**ISO Metric Coarse Thread
DIN 13**

Class of Fit
Coating
Cutting Material
Technical Characteristics



Thread Depth
and Hole Shape

Applications – Material

SPEED
High-Speed
Cutting

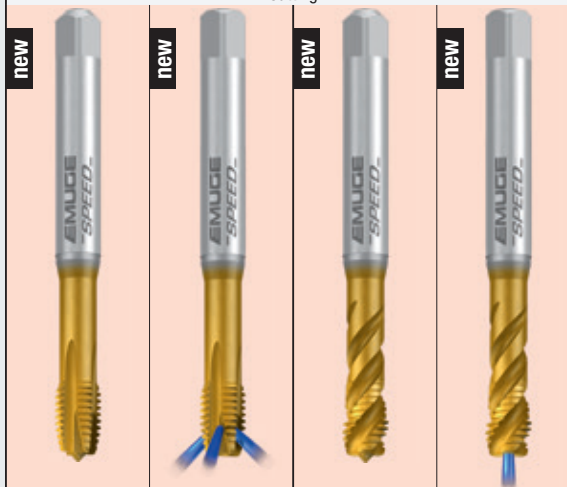

6HX	6HX	6HX	6HX
TIN-70	TIN-70	TIN-60	TIN-60
HSSE-PM	HSSE-PM	HSSE-PM	HSSE-PM
R45	R45	R45	R45
B / 4-5	B / 4-5	C / 2-3	C / 2-3
E	E	E	E

max. 3 x d₁



max. 3 x d₁



P 1.1-4.1	P 1.1-4.1	P 2.1-4.1	P 2.1-4.1
K 2.1-2	K 2.1-2		
N 1.4-6	N 1.4-6		

Reinforced Shank

Nominal Size ø d ₁	P	l ₁	mm				ø d ₂	□	Tool Identification		B3208F01		B3258F01		B3600F01		B3650F01	
			l ₂	l ₃	l ₄	l ₅			Rekord 1B-Z-SPEED PM-TIN-70	Flutes	Rekord 1B-Z-SPEED IKZN-PM TIN-70	Flutes	Enorm 1-Z-SPEED X-PM TIN-60	Flutes	Enorm 1-Z-SPEED X-1KZ-PM TIN-60	Flutes		
M 2	0.4	45	4	12	2.8	2.1	1.6	.0020										
M 2.5	0.45	50	5	14	2.8	2.1	2.05	.0025			upon							
M 3	0.5	56	6	18	3.5	2.7	2.5	.0030										
M 3.5	0.6	56	7	20	4	3	2.9	.0035										
M 4	0.7	63	7	21	4.5	3.4	3.3	.0040	★	3			★	3	★	3		
M 4.5	0.75	70	8	25	6	4.9	3.7	.0045										
M 5	0.8	70	8	25	6	4.9	4.2	.0050	★	3			★	3	★	3		
M 6	1	80	10	30	6	4.9	5	.0060	★	3			★	3	★	3		
M 8	1.25	90	14	35	8	6.2	6.8	.0080	★	4			★	3	★	3		
M 10	1.5	100	16	39	10	8	8.5	.0100	★	4			★	3	★	3		

Reduced Shank

Nominal Size ø d ₁	P	l ₁	mm				ø d ₂	□	Tool Identification		C3208F01		C3600F01		C3650F01	
			l ₂	l ₃	l ₄	l ₅			Rekord 2B-Z-SPEED PM-TIN-70	Flutes	Enorm 2-Z-SPEED X-PM TIN-60	Flutes	Enorm 2-Z-SPEED X-1KZ-PM TIN-60	Flutes		
M 12	1.75	110	18	—	9	7	10.2	.0112	★	4			★	4	★	4
M 14	2	110	20	—	11	9	12	.0114								
M 16	2	110	22	—	12	9	14	.0116	★	4			★	4	★	4
M 18	2.5	125	25	—	14	11	15.5	.0118								
M 20	2.5	140	25	—	16	12	17.5	.0120	★	4			★	4	★	4
M 22	2.5	140	27	—	18	14.5	19.5	.0122								
M 24	3	160	30	—	18	14.5	21	.0124								
M 27	3	160	30	—	20	16	24	.0127								
M 30	3.5	180	35	—	22	18	26.5	.0130								
M 33	3.5	180	35	—	25	20	29.5	.0133								
M 36	4	200	40	—	28	22	32	.0136								
M 42	4.5	200	45	—	32	24	37.5	.0142								
M 45	4.5	220	45	—	36	29	40.5	.0145								
M 48	5	250	50	—	36	29	43	.0148								
M 52	5	250	50	—	40	32	47	.0152								

● = In stock
★ = Allow 7 days for delivery

Product Finder

- V_c
- UNC
- UNF
- UNEF
- UN-8
- M**
- MF
- NPSM/NPSC
- NPSF
- R_p (BSPP)
- G
- NPT
- NPTF
- R_c (BSPT)
- STI
- SELF-LOCK
- Accessories
- Tech. Info



- Product Finder
- V_c
- UNC
- UNF
- UNEF
- UN-8
- M
- MF
- NPSM/NPSC
- NPSF
- Rp (BSPP)
- G
- NPT
- NPTF
- Rc (BSPT)
- STI
- SELF-LOCK
- Accessories
- Tech. Info

DIN Length • DIN Shank

VA
Stainless Steel
Materials



With internal chip collector

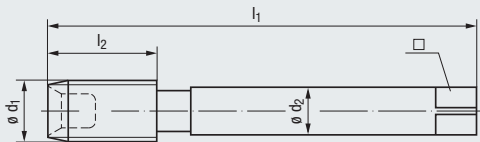

Reduced Shank

M



**ISO Metric Coarse Thread
DIN 13**

Class of Fit
Coating
Cutting Material
Technical Characteristics



Thread Depth
and Hole Shape

- 6HX
- NE2
- HSS Extra
- C / 2-3
- P / O 1)

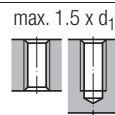

Applications – Material

- P** 1.1-4.1
- M** 1.1-2.1
- K** 1.1-4.2

Reduced Shank

Tool Identification

C0803001

Nominal Size ø d ₁	P	l ₁	mm l ₂	ø d ₂	□		Dimens. ID	Robust 2X-VA NE2	
								Flutes	
M 20	2.5	140	32	16	12	17.5	.0120	★	5
M 22	2.5	140	32	18	14.5	19.5	.0122	★	5
M 24	3	160	34	18	14.5	21	.0124	★	5
M 27	3	160	36	20	16	24	.0127	★	5
M 30	3.5	180	40	22	18	26.5	.0130	★	6
M 33	3.5	180	40	25	20	29.5	.0133	★	6
M 36	4	200	50	28	22	32	.0136	★	6
M 42	4.5	200	56	32	24	37.5	.0142	★	6
M 45	4.5	220	58	36	29	40.5	.0145	★	6
M 48	5	250	65	36	29	43	.0148	★	6
M 52	5	250	65	40	32	47	.0152	★	6
M 56	5.5	250	70	40	32	50.5	.0156	★	7
M 60	5.5	280	70	45	35	54.5	.0160	★	7
M 64	6	315	75	50	39	58	.0164	★	7
M 68	6	315	75	50	39	62	.0168	★	7

≥ M56 Shank with grooves for better handling!

1) If possible, use paste lubrication, coating both the tool and the walls of the drilled hole.
Lubrication with oil is possible only in the vertical machining of blind holes, if the hole is entirely filled with oil.

Larger sizes priced upon request.

The Complete Tool System

Robust 2X-VA Taps when used with a KSN Type tapping attachment creates the optimal tapping unit!

Extra Length • DIN Shank

Z
CNC-Controlled
Machines

Product
Finder

V_c

UNC

UNF

UNEF

UN-8

M

MF

NPSM/NPSC

NPSF

Rp (BSP)

G

NPT

NPTF

Rc (BSPT)

STI

SELF-LOCK

Accessories

Tech. Info

With long flutes and long shank for thread depths up to max. 4 x d₁

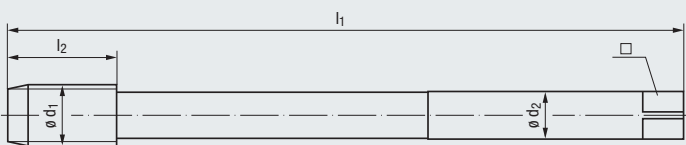

Reduced Shank

new

new

new



M
ISO Metric Coarse Thread
DIN 13

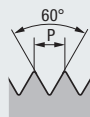

Class of Fit
Coating
Cutting Material
Technical Characteristics

6HX
TICN
HSS Extra
C / 2-3
E / O

6HX
TIN
HSS Extra
R15
C / 2-3
E / O

6HX
TIN
HSS Extra
R15
C / 2-3
E / O

Thread Depth
and Hole Shape

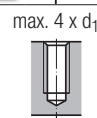
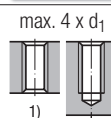

Applications – Material

P 1.1-4.1
K 1.1-4.2
N 1.4-6, 2.4-7
N 4.1

P 2.1-5.1
K 2.1-2
N 1.4-6, 2.4-5

P 2.1-5.1
K 2.1-2
N 1.4-6, 2.4-5

Reduced Shank

Tool Identification

Nominal Size ø d ₁	P	l ₁	mm l ₂	ø d ₂	□	Tool ID	C0539401		C4283701		C4063701	
							Rekord 2A-Z-IKZ-LF4 TICN	Flutes	Rekord 2D-Z-IKZ-LF4 TIN	Flutes	Rekord 2D-Z-BF-IKZ-LF4 TIN	Flutes
M 20	2.5	190	25	16	12	17.5	★	4	★	3	★	3
M 22	2.5	230	27	18	14.5	19.5	★	4	★	3	★	3
M 24	3	240	30	18	14.5	21	★	4	★	3	★	3
M 27	3	250	30	20	16	24	★	4	★	3	★	3
M 30	3.5	270	35	22	18	26.5	★	4	★	4	★	4
M 33	3.5	290	35	25	20	29.5	★	4	★	4	★	4
M 36	4	310	40	28	22	32	★	4	★	4	★	4
M 42	4.5	340	45	32	24	37.5	★	4	★	4	★	4
M 45	4.5	360	45	36	29	40.5	★	4	★	4	★	4

1) Threading in through holes is possible only with external cooling/lubrication

- Product Finder
- V_c
- UNC
- UNF
- UNEF
- UN-8
- M**
- MF
- NPSM/NPSC
- NPSF
- Rp (BSPP)
- G
- NPT
- NPTF
- Rc (BSPT)
- STI
- SELF-LOCK
- Accessories
- Tech. Info

Extra Length • DIN Shank

With extra long shank

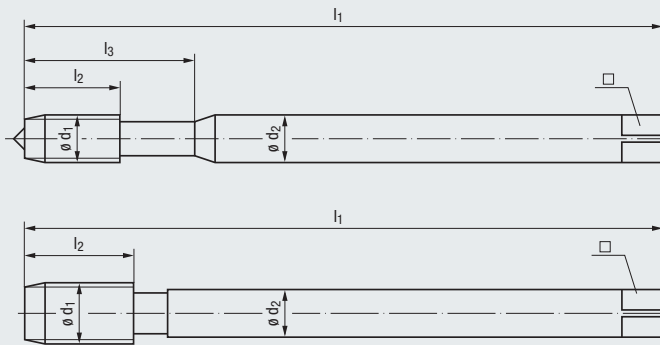

Reinforced Shank (M3 - M8)

Reduced Shank (M6 - M20)

STEEL

Steel Materials



**ISO Metric Coarse Thread
DIN 13**

Class of Fit
Coating
Cutting Material
Technical Characteristics

ISO 2/6H	ISO 2/6H	ISO 2/6H
HSS Extra	HSS Extra	HSS Extra
B / 4-5	E / 1.5-2	R35
E / 0	E / 0	C / 2-3
E / 0	E / 0	E / 0

Thread Depth and Hole Shape	max. 3 x d ₁	max. 2 x d ₁	max. 2.5 x d ₁

Applications – Material	P 1.1-3.1 N 2.2	P 2.1-3.1	P 1.1-3.1 N 2.2
-------------------------	----------------------------------	------------------	----------------------------------

Reinforced Shank

Nominal Size ø d ₁								Tool Identification		B2208900		B2461000		B2501000	
P	l ₁	l ₂	l ₃	ø d ₂	□	Dimens. ID	Rekord 1B-STEEL-L LS	Flutes	Rekord 1D-STEEL/E LS	Flutes	Enorm 1-STEEL-LS	Flutes			
M 3 0.5	100	11	18	3.5	2.7	2.5	★	3	★	3	★	3			
M 4 0.7	125	13	21	4.5	3.4	3.3	★	3	★	3	★	3			
M 5 0.8	140	15	25	6	4.9	4.2	★	3	●	3	★	3			
M 6 1	160	17	30	6	4.9	5	★	3	●	3	★	3			
M 8 1.25	180	20	35	8	6.2	6.8	★	3	●	3	★	3			

Reduced Shank

Nominal Size ø d ₁								Tool Identification		C2208900		C2461000		C2501000	
P	l ₁	l ₂	l ₃	ø d ₂	□	Dimens. ID	Rekord 2B-STEEL-L LS	Flutes	Rekord 2D-STEEL/E LS	Flutes	Enorm 2-STEEL-LS	Flutes			
M 6 1	160	17	—	4.5	3.4	5	★	3	★	3	★	3			
M 8 1.25	180	20	—	6	4.9	6.8	★	3	★	3	★	3			
M 10 1.5	200	22	—	7	5.5	8.5	★	3	★	3	★	3			
M 12 1.75	224	24	—	9	7	10.2	★	3	★	3	★	3			
M 14 2	224	26	—	11	9	12	★	3	★	3	★	3			
M 16 2	224	27	—	12	9	14	★	3	★	3	★	3			
M 18 2.5	250	30	—	14	11	15.5	★	3	★	3	★	3			
M 20 2.5	280	32	—	16	12	17.5	★	3	★	3	★	3			



ISO 2/6H	ISO 2/6H	ISO 2/6H	ISO 2/6H	6HX
NT	GLT-1		GLT-1	NT
HSS Extra	HSS Extra	HSS Extra	HSS Extra	HSS Extra
		R35	R35	
B / 4-5	B / 4-5	C / 2-3	C / 2-3	C / 2-3
E / O / P	E / O / P	E / O / P	E / O / P	E / O / P

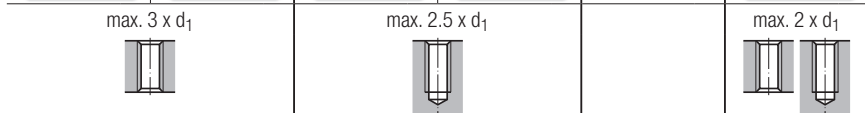

P 1.1-3.1	P 1.1-4.1	P 1.1-3.1	P 1.1-4.1	P 1.1-3.1
M 1.1-2.1	M 1.1-3.1	M 1.1-2.1	M 1.1-3.1	K 1.1-4.2
K 2.1	K 2.1	K 2.1	K 2.1	N 2.4-7
N 2.2, 2.5-6	N 2.2			N 4.1, 5.1

B2203000	B220C300	B2503000	B250C300	B2100501
Rekord 1B-VA-LS NT	Rekord 1B-VA-LS GLT-1	Enorm 1-VA-LS	Enorm 1-VA-LS GLT-1	Rekord 1A-H-LS NT
Flutes	Flutes	Flutes	Flutes	Flutes
★ 3	★ 3	★ 3	★ 3	★ 3
★ 3	upon	★ 3	★ 3	★ 3
★ 3	request	★ 3	★ 3	★ 3
★ 3		★ 3	★ 3	★ 3

C2203000	C220C300	C2503000	C2100501
Rekord 2B-VA-LS NT	Rekord 2B-VA-LS GLT-1	Enorm 2-VA-LS	Rekord 2A-H-LS NT
Flutes	Flutes	Flutes	Flutes
★ 3	★ 3	★ 3	★ 3
★ 3	upon	★ 3	★ 3
★ 3	request	★ 3	★ 3
★ 3		★ 3	★ 3
★ 3		★ 3	★ 3
★ 3		★ 3	★ 4
★ 3		★ 3	★ 4

As a further alternative to our compact types LS we can offer you our special shank extensions without and with coolant-thru (IKZ) for standard taps (see pages 132-138).

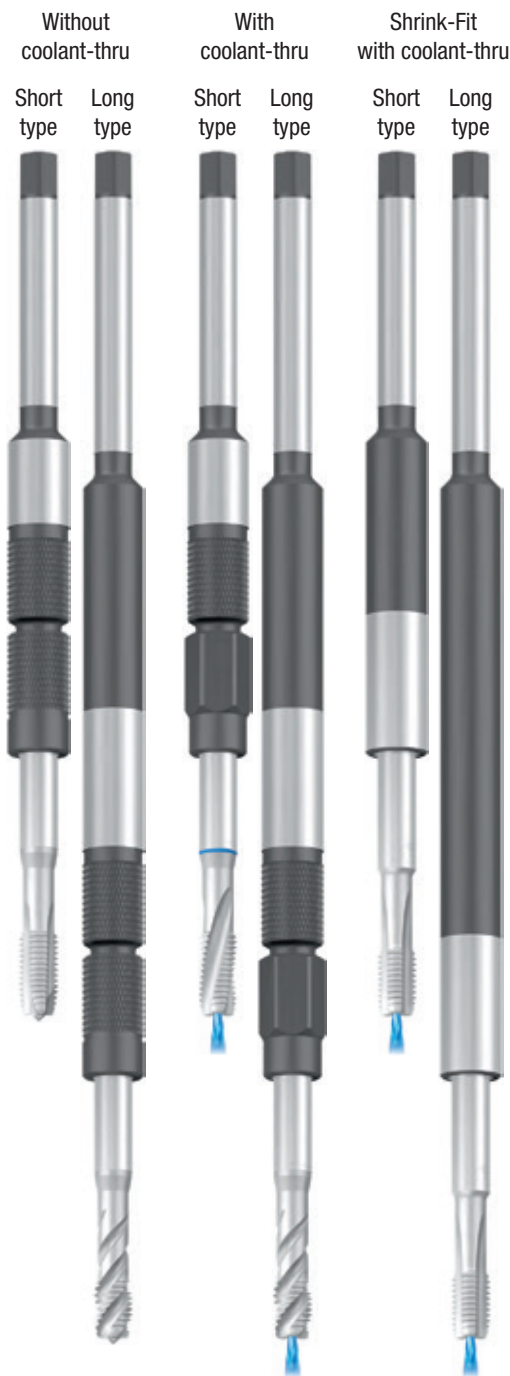

- Product Finder
- Vc
- UNC
- UNF
- UNEF
- UN-8
- M
- MF
- NPSM/NPSC
- NPSF
- Rp (BSP)
- G
- NPT
- NPTF
- Rc (BSPT)
- STI
- SELF-LOCK
- Accessories
- Tech. Info



● = In stock
★ = Allow 7 days for delivery

1) From M4 also available with IKZ (axial coolant-thru)
2) From M5 also available with IKZN (axial coolant-thru with radial flow into the flutes)

- Product Finder
- V_c
- UNC
- UNF
- UNEF
- UN-8
- M**
- MF
- NPSM/NPSC
- NPSF
- Rp (BSPP)
- G
- NPT
- NPTF
- Rc (BSPT)
- STI
- SELF-LOCK
- Accessories
- Tech. Info

ANSI Length • ANSI Shank

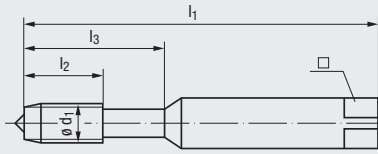

Reinforced Shank
(M4 - M10)

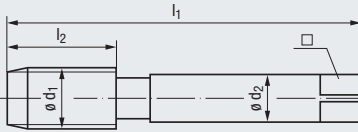

Reduced Shank
(M12 - M24)

STEEL Steel Materials



M

**ISO Metric Coarse Thread
DIN 13**

Class of Fit
Coating
Cutting Material
Technical Characteristics

ISO 2/6H	ISO 2/6H	ISO 2/6H	ISO 2/6H
TIN	TIN	TIN	TIN
HSS Extra	HSS Extra	HSS Extra	HSS Extra
R15	R15	R15	R35
B / 4-5	E / 1.5-2	E / 1.5-2	C / 2-3
E / 0	E / 0	E / 0	E / 0

Thread Depth
and Hole Shape

max. 3 x d ₁	max. 2 x d ₁	max. 2.5 x d ₁

Applications – Material

P 1.1-4.1	P 2.1-3.1	P 1.1-4.1	P 1.1-4.1
K 2.1		K 1.1-4.2	K 2.1
N 2.2, 2.4-5		N 1.4-5, 2.4-5	N 2.2









Nominal Size ϕd_1	P mm	inch				ϕd_2	\square	Tool Identification		AU208400		AU461000		AU461400		AU501400	
		l_1	l_2	l_3	ϕd_2			\square	mm	Dimens. ID	Rekord B-STEEL-L TIN	Flutes	Rekord D-STEEL/E	Flutes	Rekord D-STEEL/E TIN	Flutes	Enorm STEEL TIN
M 4	0.7	2 1/8	2.13	0.512	0.827	0.168	0.131	3.3	.0040	●	3	●	3	●	3	●	3
M 5	0.8	2 3/8	2.38	0.591	0.945	0.194	0.152	4.2	.0050	●	3	●	3	●	3	●	3
M 6	1	2 1/2	2.50	0.669	1.102	0.255	0.191	5	.0060	●	3	●	3	●	3	●	3
M 8	1.25	2 23/32	2.72	0.787	1.299	0.318	0.238	6.8	.0080	●	3	●	3	●	3	●	3
M 10	1.5	2 15/16	2.94	0.866	1.378	0.381	0.286	8.5	.0100	●	3	●	3	●	3	●	3
M 12	1.75	3 3/8	3.38	0.984	—	0.367	0.275	10.2	.0112	●	3	●	3	●	3	●	3
M 14	2	3 19/32	3.59	1.024	—	0.429	0.322	12	.0114	●	3	●	3	●	3	●	3
M 16	2	3 13/16	3.81	1.063	—	0.480	0.360	14	.0116	●	3	●	3	●	3	●	3
M 20	2.5	4 15/32	4.47	1.181	—	0.652	0.489	17.5	.0120	●	3			●	3	●	3
M 24	3	4 29/32	4.91	1.339	—	0.760	0.570	21	.0124	●	3				●	4	

DIN Length • DIN Shank

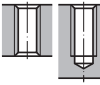

All ANSI Length • ANSI Shank taps are available in the popular DIN Length • DIN Shank style.

The DIN Length • DIN Shank configuration allows for added reach capabilities and greater chip clearance.

VA Stainless Steel Materials		H Materials of High Tensile Strength		Z CNC-Controlled Machines				
								
$l_2 \approx 10 \times P$		$l_2 \approx 10 \times P$		$l_2 \approx 10 \times P$				
ISO 2/6H	ISO 2/6H	6HX	6HX	ISO 2/6H		Class of Fit		
NT		NT	TIN	TIN		Coating		
HSS Extra	HSS Extra	HSS Extra	HSS Extra	HSS Extra		Cutting Material		
	R35			R45		Technical Characteristics		
B / 4-5	C / 2-3	E / 1.5-2	E / 1.5-2	E / 1.5-2				
E / O / P	E / O / P	E / O / P	E / O / P	E / O / P				
max. 3 x d ₁	max. 2.5 x d ₁	max. 2 x d ₁		max. 3 x d ₁		Thread Depth and Hole Shape		
								
P 1.1-3.1	P 1.1-3.1	P 1.1-3.1	P 1.1-4.1	P 1.1-4.1		Applications – Material		
M 1.1-2.1	M 1.1-2.1	K 1.1-4.2	K 1.1-4.2	M 1.1-3.1				
K 2.1	K 2.1	N 2.4-7	N 2.4-7	N 1.4-6				
N 2.2, 2.5-6		N 4.1, 5.1	N 4.1, 5.1	N 2.1-2, 2.4-5				
				S 1.1				
AU203000	AU503000	AU110501	AU110601	AU513700		Tool Identification		
Rekord B-VA NT	Enorm VA	Rekord A-H/E NT	Rekord A-H/E TIN	Enorm Z/E TIN		Dimens. ID	Nominal Size ø d ₁	P mm
Flutes	Flutes	Flutes	Flutes	Flutes				
●	●	●	●	●		.0040	M 4	0.7
●	●	●	●	●		.0050	M 5	0.8
●	●	●	●	●	●	.0060	M 6	1
●	●	●	●	●	●	.0080	M 8	1.25
●	●	●	●	●	●	.0100	M 10	1.5
●	●	●	●	●	●	.0112	M 12	1.75
●	●	●	●	●	●	.0114	M 14	2
●	●	●	●	●		.0116	M 16	2
●	●	●	●	●		.0120	M 20	2.5
●	●	●	●	●		.0124	M 24	3

- Product Finder
- V_c
- UNC
- UNF
- UNEF
- UN-8
- M
- MF
- NPSM/NPSC
- NPSF
- Rp (BSPP)
- G
- NPT
- NPTF
- Rc (BSPT)
- STI
- SELF-LOCK
- Accessories
- Tech. Info



● = In stock
★ = Allow 7 days for delivery

- Product Finder
- V_c
- UNC
- UNF
- UNEF
- UN-8
- M
- MF
- NPSM/NPSC
- NPSF
- Rp (BSPP)
- G
- NPT
- NPTF
- Rc (BSPT)
- STI
- SELF-LOCK
- Accessories
- Tech. Info

DIN Length • DIN Shank

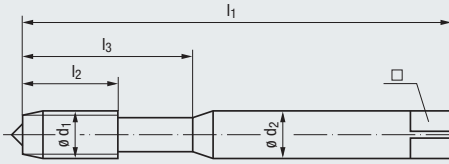

Reinforced Shank
(M3x0.35 - M10x1.25)

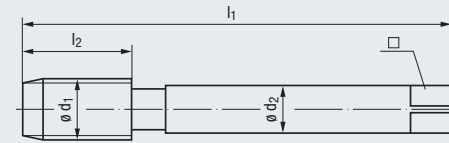

Reduced Shank
(M8x1 - M30x2)

MF

**ISO Metric Fine Thread
DIN 13**

Class of Fit
Coating
Cutting Material
Technical Characteristics



Applications – Material

STEEL Steel Materials



ISO 2/6H	ISO 2/6H	ISO 3/6G	ISO 2/6H	ISO 2/6H
HSS Extra	HSS Extra	HSS Extra	HSS Extra	HSS Extra
B / 4-5	B / 4-5	B / 4-5	B / 4-5	C / 2-3
E / 0	E / 0	E / 0	E / 0	E / 0

max. 3 x d₁



max. 2 x d₁









P 1.1-3.1	P 1.1-4.1	P 1.1-3.1	P 1.1-3.1	P 1.1-4.1
N 2.2	K 2.1	N 2.2	N 2.2	K 1.1-4.2
	N 2.2, 2.4-5			N 1.4-5, 2.4-5

Reinforced Shank

Nominal Size ø d ₁	P	mm			ø d ₂	□	Tool Identification		B0208900		B0208400	
		l ₁	l ₂	l ₃			Rekord 1B-STEEL-L	Flutes	Rekord 1B-STEEL-L TIN	Flutes		
M 3 x 0.35	56	8	18	3.5	2.7	2.65	.0202	●	3	●	3	
M 4 x 0.5	63	10	21	4.5	3.4	3.5	.0210	●	3	●	3	
M 5 x 0.5	70	11	25	6	4.9	4.5	.0218	●	3	●	3	
M 6 x 0.75	80	13	30	6	4.9	5.2	.0229	●	3	●	3	
M 8 x 0.75	80	14	30	8	6.2	7.2	.0250	●	3	●	3	
M 8 x 1	90	17	35	8	6.2	7	.0251	●	3	●	3	
M 10 x 1	90	18	35	10	8	9	.0276	●	4	●	4	
M 10 x 1.25	100	18	39	10	8	8.8	.0277	●	3	●	3	

Reduced Shank

Nominal Size ø d ₁	P	mm			ø d ₂	□	Tool Identification		C0208900		C0208400		C0208920		C0208950		C0451400	
		l ₁	l ₂	l ₃			Rekord 2B-STEEL-L	Flutes	Rekord 2B-STEEL-L TIN	Flutes	Rekord 2B-STEEL-L	Flutes	Rekord 2B-STEEL-L LH	Flutes	Rekord 2D-STEEL TIN	Flutes		
M 8 x 1	90	17	—	6	4.9	7	.0251	●	3	●	3	★	3	★	3	★	3	
M 10 x 1	90	18	—	7	5.5	9	.0276	●	4	●	4	★	4	★	4	★	4	
M 10 x 1.25	100	22	—	7	5.5	8.8	.0277	●	3	●	3	★	3	★	3	★	3	
M 12 x 1.5	100	22	—	9	7	10.5	.0303	●	3	●	3	★	3	★	3	★	3	
M 14 x 1.5	100	22	—	11	9	12.5	.0331	●	3	●	3	★	3	★	3	★	3	
M 16 x 1.5	100	22	—	12	9	14.5	.0359	●	3	●	3	★	3	★	3	★	3	
M 18 x 1.5	110	25	—	14	11	16.5	.0390	●	4	●	4	★	4	★	4	★	4	
M 20 x 1.5	125	25	—	16	12	18.5	.0422	●	4	●	4	★	4	★	4	★	4	
M 22 x 1.5	125	25	—	18	14.5	20.5	.0438	★	4	★	4							
M 22 x 2	140	27	—	18	14.5	20	.0439	★	3	★	3							
M 24 x 1.5	140	27	—	18	14.5	22.5	.0452	★	4	★	4							
M 24 x 2	140	27	—	18	14.5	22	.0453	★	4	★	4							
M 27 x 1.5	140	28	—	20	16	25.5	.0470	★	5	★	5							
M 27 x 2	140	28	—	20	16	25	.0471	★	4	★	4							
M 30 x 1.5	150	28	—	22	18	28.5	.0490	★	5	★	5							
M 30 x 2	150	28	—	22	18	28	.0491	★	4	★	4							

STEEL Steel Materials				VA Stainless Steel Materials												
																
ISO 2/6H TIN HSS Extra R15 E / 1.5-2 E / O	ISO 2/6H HSS Extra R35 C / 2-3 E / O	ISO 2/6H TIN HSS Extra R35 C / 2-3 E / O	ISO 2/6H HSS Extra LH, L35 C / 2-3 E / O	ISO 2/6H GLT-1 HSS Extra B / 4-5 E / O / P	ISO 2/6H NE2 HSS Extra R35 C / 2-3 E / O / P	ISO 2/6H GLT-1 HSS Extra R35 C / 2-3 E / O / P	Class of Fit Coating Cutting Material Technical Characteristics									
max. 2 x d ₁	max. 2.5 x d ₁			max. 3 x d ₁	max. 2.5 x d ₁		Thread Depth and Hole Shape									
P 1.1-4.1 K 1.1-4.2 N 1.4-5, 2.4-5	P 1.1-3.1 N 2.2	P 1.1-4.1 K 2.1 N 2.2	P 1.1-3.1 N 2.2	P 1.1-4.1 M 1.1-3.1 K 2.1 N 2.2	P 1.1-3.1 M 1.1-2.1 K 2.1	P 1.1-4.1 M 1.1-3.1 K 2.1	Applications – Material									
B0501000		B0501400		B0503200		B050C300		Tool Identification								
Enorm 1-STEEL		Enorm 1-STEEL TIN		Enorm 1-VA NE2		Enorm 1-VA GLT-1		Dimens. ID	Nominal Size ø d ₁	P						
Flutes		Flutes		Flutes		Flutes										
★	3	★	3	●	3	★	3	.0202	M 3 x 0.35							
★	3	★	3	●	3	★	3	.0210	M 4 x 0.5							
★	3	★	3	●	3	★	3	.0218	M 5 x 0.5							
★	3	★	3	●	3	★	3	.0229	M 6 x 0.75							
★	3	★	3	●	3			.0250	M 8 x 0.75							
★	3	★	3					.0251	M 8 x 1							
★	3	★	3					.0276	M 10 x 1							
★	3	★	3	●	3			.0277	M 10 x 1.25							
C0461400		C0501000		C0501400		C0501050		C020C300		C0503200		C050C300		Tool Identification		
Rekord 2D-STEEL/E TIN		Enorm 2-STEEL		Enorm 2-STEEL TIN		Enorm 2-STEEL-LH		Rekord 2B-VA GLT-1		Enorm 2-VA NE2		Enorm 2-VA GLT-1		Dimens. ID	Nominal Size ø d ₁	P
Flutes		Flutes		Flutes		Flutes		Flutes		Flutes		Flutes				
★	3	★	3	★	3	★	3	★	3	●	3	★	3	.0251	M 8 x 1	
★	3	★	3	★	3	★	3	★	4	●	3	★	3	.0276	M 10 x 1	
★	3	★	3	★	3	★	3	★	4	●	3	★	3	.0277	M 10 x 1.25	
★	3	★	4	★	4	★	4	★	3	●	4	★	4	.0303	M 12 x 1.5	
★	3	★	4	★	4	★	4	★	3	●	4	★	4	.0331	M 14 x 1.5	
★	3	★	4	★	4	★	4	★	3	●	4	★	4	.0359	M 16 x 1.5	
★	4	★	4	★	4	★	4	★	4	●	4	★	4	.0390	M 18 x 1.5	
★	4	★	4	★	4	★	4	★	4	●	4	★	4	.0422	M 20 x 1.5	
★	4	★	4		4		4		4	●	4		4	.0438	M 22 x 1.5	
★	4	★	4		4		4		4	●	4		4	.0439	M 22 x 2	
★	4	★	5		5		5		4	●	4		4	.0452	M 24 x 1.5	
		★	4		4		4		4	●	4		4	.0453	M 24 x 2	
		★	5		5		5		4	●	4		4	.0470	M 27 x 1.5	
		★	4		4		4		4	●	4		4	.0471	M 27 x 2	
		★	6		6		6		6	●	6		6	.0490	M 30 x 1.5	
		★	5		5		5		6	●	6		6	.0491	M 30 x 2	

● = In stock
★ = Allow 7 days for delivery

Product Finder

- Vc
- UNC
- UNF
- UNEF
- UN-8
- MF
- NPSM/NPSC
- NPSF
- Rp (BSPP)
- G
- NPT
- NPTF
- Rc (BSPT)
- STI
- SELF-LOCK
- Accessories
- Tech. Info



- Product Finder
- V_c
- UNC
- UNF
- UNEF
- UN-8
- M
- MF**
- NPSM/NPSC
- NPSF
- Rp (BSPP)
- G
- NPT
- NPTF
- Rc (BSPT)
- STI
- SELF-LOCK
- Accessories
- Tech. Info

DIN Length · DIN Shank

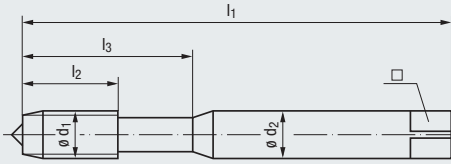

Reinforced Shank
(M3x0.35 - M10x1.25)

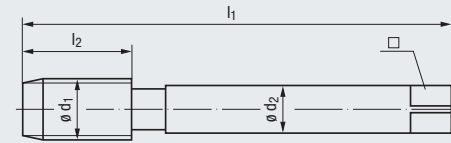

Reduced Shank
(M8x1 - M30x2)

MF

**ISO Metric Fine Thread
DIN 13**

Class of Fit
Coating
Cutting Material
Technical Characteristics



Applications – Material















GJV Cast Iron Vermicular				
new	new	new	new	new
6HX	6HX	6HX	6HX	6HX
TICN	TICN	TICN	TICN	TICN
HSSE-PM	HSSE-PM	HSSE-PM	HSSE-PM	HSSE-PM
C / 2-3	C / 2-3	C / 2-3	E / 1.5-2	E / 1.5-2
E	E	E	E	E
max. 2 x d ₁	max. 2 x d ₁	max. 2 x d ₁	max. 2 x d ₁	max. 2 x d ₁
K 1.1-4.2	K 1.1-4.2	K 1.1-4.2	K 1.1-4.2	K 1.1-4.2

Reinforced Shank

Nominal Size ø d ₁	P	mm			ø d ₂	□	Tool Identification									
		l ₁	l ₂	l ₃			Dimens. ID									
M 3 x 0.35	56	8	18	3.5	2.7	2.65	.0202									
M 4 x 0.5	63	10	21	4.5	3.4	3.5	.0210									
M 5 x 0.5	70	11	25	6	4.9	4.5	.0218									
M 6 x 0.75	80	13	30	6	4.9	5.2	.0229									
M 8 x 0.75	80	14	30	8	6.2	7.2	.0250									
M 8 x 1	90	17	35	8	6.2	7	.0251									
M 10 x 1	90	18	35	10	8	9	.0276									
M 10 x 1.25	100	18	39	10	8	8.8	.0277									

Reduced Shank

Nominal Size ø d ₁	P	mm			ø d ₂	□	Tool Identification		C010R501		C195R501		C106R501		C011R501		C196R501	
		l ₁	l ₂	l ₃			Dimens. ID	Rekord 2A-GJV PM-TICN	Flutes	Rekord 2A-GJV IKZ-PM TICN	Flutes	Rekord 2A-GJV IKZN-PM TICN	Flutes	Rekord 2A-GJV/E PM-TICN	Flutes	Rekord 2A-GJV/E IKZ-PM TICN	Flutes	
M 8 x 1	90	17	—	6	4.9	7	.0251											
M 10 x 1	90	18	—	7	5.5	9	.0276					upon						
M 10 x 1.25	100	22	—	7	5.5	8.8	.0277											
M 12 x 1.5	100	22	—	9	7	10.5	.0303	★	4	★	4	request	★	4	★	4	★	4
M 14 x 1.5	100	22	—	11	9	12.5	.0331	★	4	★	4		★	4	★	4	★	4
M 16 x 1.5	100	22	—	12	9	14.5	.0359	★	4	★	4		★	4	★	4	★	4
M 18 x 1.5	110	25	—	14	11	16.5	.0390	★	4	★	4		★	4	★	4	★	4
M 20 x 1.5	125	25	—	16	12	18.5	.0422	★	4	★	4		★	4	★	4	★	4
M 22 x 1.5	125	25	—	18	14.5	20.5	.0438											
M 22 x 2	140	27	—	18	14.5	20	.0439											
M 24 x 1.5	140	27	—	18	14.5	22.5	.0452											
M 24 x 2	140	27	—	18	14.5	22	.0453											
M 27 x 1.5	140	28	—	20	16	25.5	.0470											
M 27 x 2	140	28	—	20	16	25	.0471											
M 30 x 1.5	150	28	—	22	18	28.5	.0490											
M 30 x 2	150	28	—	22	18	28	.0491											

GJV Cast Iron Vermicular		H Materials of High Tensile Strength						
								
								6HX TICN HSSE-PM E / 1.5-2 E
max. 2 x d ₁ 	max. 2 x d ₁ 	max. 2 x d ₁ 	max. 2 x d ₁ 	max. 2 x d ₁ 	max. 2 x d ₁ 	max. 2 x d ₁ 	Thread Depth and Hole Shape	
K 1.1-4.2	P 1.1-3.1 K 1.1-4.2 N 2.4-7 N 4.1, 5.1	P 1.1-4.1 K 1.1-4.2 N 2.4-7 N 4.1, 5.1	P 1.1-4.1 K 1.1-4.2 N 2.4-7 N 4.1, 5.1	P 1.1-4.1 K 1.1-4.2 N 2.4-7 N 4.1, 5.1	P 5.1 K 1.1-4.2 N 1.5-6, 2.6-8 N 4.1, 4.3-5.2 H 1.1-2	Applications – Material		
		B0100501			B1950901		Tool Identification	
		Rekord 1A-H NT Flutes				VHM Rekord 1A-H-IKZ Flutes	Dimens. ID Nominal Size ø d ₁ P	
		★ 3				★ 3	.0202 M 3 x 0.35	
		★ 3					.0210 M 4 x 0.5	
		★ 3					.0218 M 5 x 0.5	
		★ 3					.0229 M 6 x 0.75	
							.0250 M 8 x 0.75	
						★ 3	.0251 M 8 x 1	
						★ 4	.0276 M 10 x 1	
						★ 3	.0277 M 10 x 1.25	
C109R501		C0100501	C0109101	C1959101	C1069101	C1950901	Tool Identification	
Rekord 2A-GJV/E IKZN-PM TICN Flutes		Rekord 2A-H NT Flutes	Rekord 2A-H TICN Flutes	Rekord 2A-H-IKZ TICN Flutes	Rekord 2A-H-IKZN TICN Flutes	KHM Rekord 2A-H-IKZ Flutes	Dimens. ID Nominal Size ø d ₁ P	
upon		● 3	★ 3				.0251 M 8 x 1	
		● 4	★ 4		upon		.0276 M 10 x 1	
request			★ 3				.0277 M 10 x 1.25	
		● 4	★ 4	★ 4	★ 4	★ 4	.0303 M 12 x 1.5	
		● 4	★ 4	★ 4	★ 4	★ 4	.0331 M 14 x 1.5	
		● 4	★ 4	★ 4	★ 4	★ 4	.0359 M 16 x 1.5	
		● 4	★ 4	★ 4	★ 4	★ 4	.0390 M 18 x 1.5	
		● 4	★ 4	★ 4	★ 4	★ 4	.0422 M 20 x 1.5	
			★ 4				.0438 M 22 x 1.5	
			★ 4				.0439 M 22 x 2	
			★ 4				.0452 M 24 x 1.5	
							.0453 M 24 x 2	
							.0470 M 27 x 1.5	
							.0471 M 27 x 2	
							.0490 M 30 x 1.5	
							.0491 M 30 x 2	

● = In stock
★ = Allow 7 days for delivery

1) Threading in through holes is possible only with external cooling/lubrication

Product Finder

- V_c
- UNC
- UNF
- UNEF
- UN-8
- MF
- NPSM/NPSC
- NPSF
- Rp (BSPP)
- G
- NPT
- NPTF
- Rc (BSPT)
- STI
- SELF-LOCK
- Accessories
- Tech. Info



- Product Finder
- V_c
- UNC
- UNF
- UNEF
- UN-8
- M
- MF
- NPSM/NPSC
- NPSF
- Rp (BSPP)
- G
- NPT
- NPTF
- Rc (BSPT)
- STI
- SELF-LOCK
- Accessories
- Tech. Info

DIN Length • DIN Shank

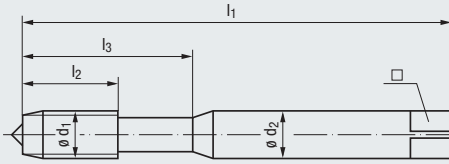

Reinforced Shank
(M8x1 - M10x1)

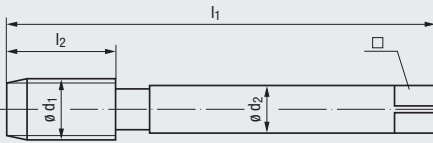

Reduced Shank
(M12x1.5 - M16x1.5)

HCUT
Hardened
Steels



MF

**ISO Metric Fine Thread
DIN 13**

Class of Fit
Coating
Cutting Material
Technical Characteristics



Thread Depth
and Hole Shape

- 6HX
- TICN
- HSSE-PM**
- C / 2-3
- O / P

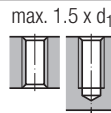

Applications – Material

H 1.1-2

Reinforced Shank

Nominal Size								Tool Identification		B010J901		
Size	P	l ₁	l ₂	l ₃	Ø d ₂	□	mm	Image	Dimens. ID	Rekord 1A-HCUT-PM TICN	Flutes	
M 8 x 1	1	90	10	35	8	6.2	mm		7.1	.0251	★	5
M 10 x 1	1	90	10	35	10	8	mm		9.1	.0276	★	5

Reduced Shank

Nominal Size								Tool Identification		C010J901		
Size	P	l ₁	l ₂	l ₃	Ø d ₂	□	mm	Image	Dimens. ID	Rekord 2A-HCUT-PM TICN	Flutes	
M 12 x 1.5	1.5	100	15	—	9	7	mm		10.6	.0303	★	5
M 14 x 1.5	1.5	100	15	—	11	9	mm		12.6	.0331	★	6
M 16 x 1.5	1.5	100	15	—	12	9	mm		14.6	.0359	★	6

DIN Length • DIN Shank

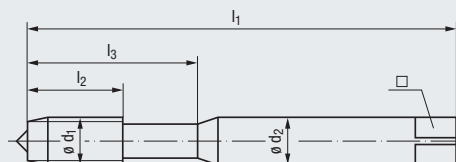

Reinforced Shank

HCUT
Hardened
Steels



2)

MF

**ISO Metric Fine Thread
DIN 13**

Class of Fit
Coating
Cutting Material
Technical Characteristics

6HX	6HX
TICN	TICN
Carbide	Carbide
D / 4-5	C / 2-3
O / P	O / P

Thread Depth
and Hole Shape

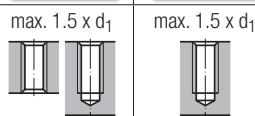

Applications – Material

H 1.3-4 H 1.3-4

Reinforced Shank

Nominal Size ø d ₁	P	mm					□	Tool Identification		B016K101		B010K101	
		l ₁	l ₂	l ₃	ø d ₂	□		Dimens. ID	VHM Rekord 1A-HCUT/D TICN	Flutes	VHM Rekord 1A-HCUT/C TICN	Flutes	
M 8 x 1		90	15	35	8	6.2	7.1	.0251	★	5	★	5	
M 10 x 1		100	18	38	10	8	9.1	.0276	★	5	★	5	
M 12 x 1.5		110	21	41	12	9	10.6	.0303	★	5	★	5	
M 14 x 1.5		110	24	44	14	11	12.6	.0331	★	6	★	6	
M 16 x 1.5		110	24	44	16	12	14.6	.0359	★	6	★	6	

2) Please note: Use solid carbide tap VHM-Rekord 1A-HCUT/D-TICN as No.1 tap!

- Product Finder
- V_c
- UNC
- UNF
- UNEF
- UN-8
- ...
- MF**
- NPSM/NPSC
- NPSF
- R_p (BSPP)
- G
- NPT
- NTF
- R_c (BSPT)
- STI
- SELF-LOCK
- Accessories
- Tech. Info



- Product Finder
- V_c
- UNC
- UNF
- UNEF
- UN-8
- M
- MF**
- NPSM/NPSC
- NPSF
- Rp (BSPP)
- G
- NPT
- NPTF
- Rc (BSPT)
- STI
- SELF-LOCK
- Accessories
- Tech. Info

DIN Length - DIN Shank

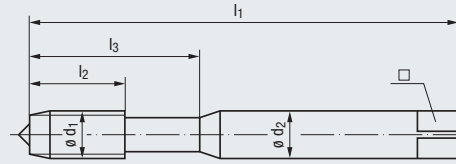

Reinforced Shank
(M3x0.35 - M10x1.25)

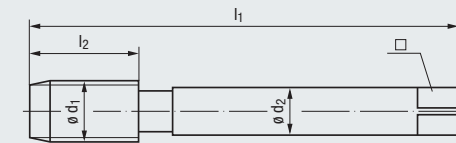

Reduced Shank
(M8x1 - M30x2)

MF

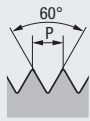

ISO Metric Fine Thread
DIN 13

Class of Fit
Coating
Cutting Material
Technical Characteristics



Thread Depth and Hole Shape

Applications - Material

Z
CNC-Controlled
Machines



6HX	6HX	6HX	6HX	6HX
TICN	TICN	TICN	TICN	TICN
HSS Extra	HSS Extra	HSS Extra	HSS Extra	HSS Extra
C / 2-3	C / 2-3	C / 2-3	E / 1.5-2	E / 1.5-2
E / O / P	E / O	E / O	E / O / P	E / O

max. 2 x d ₁	max. 2 x d ₁	max. 2 x d ₁	max. 2 x d ₁	max. 2 x d ₁

P 1.1-4.1	P 1.1-4.1	P 1.1-4.1	P 1.1-4.1	P 1.1-4.1
K 1.1-4.2	K 1.1-4.2	K 1.1-4.2	K 1.1-4.2	K 1.1-4.2
N 1.4-6, 2.4-7	N 1.4-6, 2.4-7	N 1.4-6, 2.4-7	N 1.4-6, 2.4-7	N 1.4-6, 2.4-7
N 4.1	N 4.1	N 4.1	N 4.1	N 4.1

Reinforced Shank

Nominal Size $\varnothing d_1$	P	l ₁	l ₂	l ₃	$\varnothing d_2$	□
M 3 x 0.35	56	4.5	18	3.5	2.7	
M 4 x 0.5	63	5	21	4.5	3.4	
M 5 x 0.5	70	5	25	6	4.9	
M 6 x 0.75	80	8	30	6	4.9	
M 8 x 0.75	80	8	30	8	6.2	
M 8 x 1	90	10	35	8	6.2	
M 10 x 1	90	10	35	10	8	
M 10 x 1.25	100	16	39	10	8	

Tool Identification						
Image	Dimens. ID					
	.0202					
	.0210					
	.0218					
	.0229					
	.0250					
	.0251					
	.0276					
	.0277					

Reduced Shank



Nominal Size $\varnothing d_1$	P	l ₁	l ₂	l ₃	$\varnothing d_2$	□
M 8 x 1	90	10	—	6	4.9	
M 10 x 1	90	10	—	7	5.5	
M 10 x 1.25	100	16	—	7	5.5	
M 12 x 1.5	100	15	—	9	7	
M 14 x 1.5	100	15	—	11	9	
M 16 x 1.5	100	15	—	12	9	
M 18 x 1.5	110	17	—	14	11	
M 20 x 1.5	125	17	—	16	12	
M 22 x 1.5	125	17	—	18	14.5	
M 22 x 2	140	20	—	18	14.5	
M 24 x 1.5	140	20	—	18	14.5	
M 24 x 2	140	20	—	18	14.5	
M 27 x 1.5	140	20	—	20	16	
M 27 x 2	140	20	—	20	16	
M 30 x 1.5	150	22	—	22	18	
M 30 x 2	150	22	—	22	18	

Tool Identification		C0109401	C1959401	C1069401	C0119401	C1969401
Image	Dimens. ID	Rekord 2A-Z TICN	Rekord 2A-Z-IKZ TICN	Rekord 2A-Z-IKZN TICN	Rekord 2A-Z/E TICN	Rekord 2A-Z/E-IKZ TICN
	.0251	★	★	★	★	★
	.0276	★	●	★	★	★
	.0277	★	●	★	★	★
	.0303	★	★	★	★	★
	.0331	★	★	★	★	★
	.0359	★	★	★	★	★
	.0390					
	.0422					
	.0438					
	.0439					
	.0452					
	.0453					
	.0470					
	.0471					
	.0490					
	.0491					

Z
CNC-Controlled
Machines



6HX	6HX	6HX	6HX	6HX	6HX	6HX	6HX
TIN-70	GLT-1	TIN-70	GLT-1	TIN	TIN	TIN	TIN
HSSE-PM	HSSE-PM	HSSE-PM	HSSE-PM	HSS Extra	HSS Extra	HSS Extra	HSS Extra
B / 4-5	B / 4-5	B / 4-5	B / 4-5	R15	R15	R15	R15
E / O / P	E / O / P	E / O	E / O	C / 2-3	C / 2-3	E / 1.5-2	C / 2-3
				E / O / P	E / O	E / O	E / O

Class of Fit
Coating
Cutting Material
Technical Characteristics



max. 3 x d₁



max. 2 x d₁



Thread Depth and Hole Shape

P 1.1-5.1	P 1.1-5.1	P 1.1-5.1	P 1.1-5.1	P 2.1-5.1	P 2.1-5.1	P 2.1-5.1	P 2.1-5.1
M 1.1-3.1	M 1.1-3.1	M 1.1-3.1	M 1.1-3.1	K 2.1-2	K 2.1-2	K 2.1-2	K 2.1-2
K 2.1	K 2.1	K 2.1	K 2.1	N 1.4-6, 2.4-5	N 1.4-6, 2.4-5	N 1.4-6, 2.4-5	N 1.4-6, 2.4-5
N 1.4-2.2, 2.4-5	N 1.4-2.2, 2.4-5	N 1.4-2.2, 2.4-5	N 1.4-2.2, 2.4-5				
S 1.1	S 1.1	S 1.1	S 1.1				

Applications – Material

B0208F01		B020A601										Tool Identification	
Rekord 1B-Z-PM TIN-70	Flutes	Rekord 1B-Z-PM GLT-1	Flutes							Dimens. ID	Nominal Size ø d ₁	P	
★	3	★	3							.0202	M 3 x 0.35		
★	3	★	3							.0210	M 4 x 0.5		
										.0218	M 5 x 0.5		
										.0229	M 6 x 0.75		
										.0250	M 8 x 0.75		
										.0251	M 8 x 1		
										.0276	M 10 x 1		
										.0277	M 10 x 1.25		

C0208F01		C020A601		C1088F01		C108A601		C0453701		C0963701		C0983701		C4253701		Tool Identification		
Rekord 2B-Z-PM TIN-70	Flutes	Rekord 2B-Z-PM GLT-1	Flutes	Rekord 2B-Z-PM-TIN-70	Flutes	Rekord 2B-Z-PM-GLT-1	Flutes	Rekord 2D-Z TIN	Flutes	Rekord 2D-Z-1KZ TIN	Flutes	Rekord 2D-Z/E-1KZ TIN	Flutes	Rekord 2D-Z-BF 1KZ-TIN	Flutes	Dimens. ID	Nominal Size ø d ₁	P
★	4	★	4					★	3	★	3	★	3	★	3	.0251	M 8 x 1	
★	4	★	4	upon		upon		★	3	★	3	★	3	★	3	.0276	M 10 x 1	
★	4	★	4					★	3	★	3	★	3	★	3	.0277	M 10 x 1.25	
★	4	★	4	request		request		★	3	★	3	★	3	★	3	.0303	M 12 x 1.5	
★	4	★	4							★	3	★	3	★	3	.0331	M 14 x 1.5	
★	4	★	4							★	3	★	3	★	3	.0359	M 16 x 1.5	
★	4	★	4											★	3	.0390	M 18 x 1.5	
★	4	★	4													.0422	M 20 x 1.5	
																.0438	M 22 x 1.5	
																.0439	M 22 x 2	
																.0452	M 24 x 1.5	
																.0453	M 24 x 2	
																.0470	M 27 x 1.5	
																.0471	M 27 x 2	
																.0490	M 30 x 1.5	
																.0491	M 30 x 2	

● = In stock
★ = Allow 7 days for delivery

Product Finder

- V_c
- UNC
- UNF
- UNEF
- UN-8
- MF
- NPSM/NPSC
- NPSF
- R_p (BSPP)
- G
- NPT
- NPTF
- R_c (BSPT)
- STI
- SELF-LOCK
- Accessories
- Tech. Info



- Product Finder
- V_c
- UNC
- UNF
- UNEF
- UN-8
- M
- MF**
- NPSM/NPSC
- NPSF
- Rp (BSPP)
- G
- NPT
- NPTF
- Rc (BSPT)
- STI
- SELF-LOCK
- Accessories
- Tech. Info

DIN Length • DIN Shank

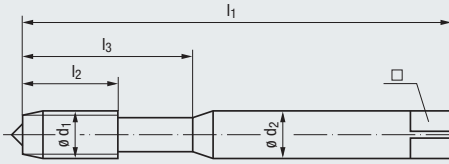

Reinforced Shank
(M3x0.35 - M10x1.25)

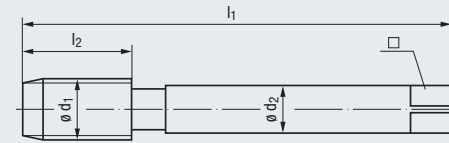

Reduced Shank
(M8x1 - M30x2)

MF

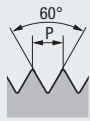

ISO Metric Fine Thread
DIN 13

Class of Fit

Coating

Cutting Material

Technical Characteristics



Thread Depth
and Hole Shape

Applications – Material

Z
CNC-Controlled
Machines

new



6HX	ISO 2/6H	ISO 2/6H	ISO 2/6H	ISO 2/6H
TIN		TIN	GLT-1	TIN
HSS Extra	HSS Extra	HSS Extra	HSS Extra	HSS Extra
R15	R45	R45	R45	R45
E / 1.5-2	E / 1.5-2	E / 1.5-2	E / 1.5-2	E / 1.5-2
E / 0	E / 0 / P	E / 0 / P	E / 0 / P	E / 0

max. 2 x d ₁	max. 3 x d ₁			











P 2.1-5.1	P 1.1-4.1	P 1.1-4.1	P 1.1-4.1	P 1.1-4.1
K 2.1-2	M 1.1-2.1	M 1.1-3.1	M 1.1-3.1	M 1.1-3.1
N 1.4-6, 2.4-5	N 2.1	N 1.4-6	N 1.4-6	N 1.4-6
		N 2.1-2, 2.4-5	N 2.1-2, 2.4-5	N 2.1-2, 2.4-5
		S 1.1	S 1.1	S 1.1

Reinforced Shank

Nominal Size ø d ₁	P	mm						ø d ₂	□	Tool Identification	B0513500		B0513700	
		l ₁	l ₂	l ₃	□	Dimens. ID	Enorm 1-Z/E				Flutes	Enorm 1-Z/E TIN	Flutes	
M 3 x 0.35	56	4.5	18	3.5	2.7	2.65	.0202							
M 4 x 0.5	63	5	21	4.5	3.4	3.5	.0210			*	3	*	3	
M 5 x 0.5	70	5	25	6	4.9	4.5	.0218			*	3	*	3	
M 6 x 0.75	80	8	30	6	4.9	5.2	.0229			*	3	*	3	
M 8 x 0.75	80	8	30	8	6.2	7.2	.0250							
M 8 x 1	90	10	35	8	6.2	7	.0251							
M 10 x 1	90	10	35	10	8	9	.0276							
M 10 x 1.25	100	16	39	10	8	8.8	.0277							

Reduced Shank

Nominal Size ø d ₁	P	mm						ø d ₂	□	Tool Identification	C4053701		C0513500		C0513700		C051C400		C0973700	
		l ₁	l ₂	l ₃	□	Dimens. ID	Rekord 2D-Z/E-BF IKZ-TIN				Flutes	Enorm 2-Z/E	Flutes	Enorm 2-Z/E TIN	Flutes	Enorm 2-Z/E GLT-1	Flutes	Enorm 2-Z/E-1KZ TIN	Flutes	
M 8 x 1	90	10	—	6	4.9	7	.0251		*	3	*	3	*	3	*	3	*	3		
M 10 x 1	90	10	—	7	5.5	9	.0276		*	3	*	4	*	4	*	4	*	4		
M 10 x 1.25	100	16	—	7	5.5	8.8	.0277		*	3	*	3	*	3	*	3	*	3		
M 12 x 1.5	100	15	—	9	7	10.5	.0303		*	3	*	5	*	5	*	5	*	5	*	5
M 14 x 1.5	100	15	—	11	9	12.5	.0331		*	3	*	5	*	5	*	5	*	5	*	5
M 16 x 1.5	100	15	—	12	9	14.5	.0359		*	3	*	5	*	5	*	5	*	5	*	5
M 18 x 1.5	110	17	—	14	11	16.5	.0390		*	5	*	5	*	5	*	5	*	5	*	5
M 20 x 1.5	125	17	—	16	12	18.5	.0422		*	5	*	5	*	5	*	5	*	5	*	5
M 22 x 1.5	125	17	—	18	14.5	20.5	.0438													
M 22 x 2	140	20	—	18	14.5	20	.0439													
M 24 x 1.5	140	20	—	18	14.5	22.5	.0452													
M 24 x 2	140	20	—	18	14.5	22	.0453													
M 27 x 1.5	140	20	—	20	16	25.5	.0470													
M 27 x 2	140	20	—	20	16	25	.0471													
M 30 x 1.5	150	22	—	22	18	28.5	.0490													
M 30 x 2	150	22	—	22	18	28	.0491													

Z CNC-Controlled Machines		SPEED High-Speed Cutting								
										
ISO 3/6G		6HX	6HX	6HX	6HX	6HX	6HX	Class of Fit		
TIN		TICN	TICN	TICN	TICN	TIN-70	TIN-70	Coating		
HSS Extra		HSS Extra	HSS Extra	HSS Extra	HSS Extra	HSSE-PM	HSSE-PM	Cutting Material		
R45								Technical Characteristics		
E / 1.5-2		C / 2-3	C / 2-3	E / 1.5-2	E / 1.5-2	B / 4-5	B / 4-5			
E / O / P		E	E	E	E	E	E			
max. 3 x d ₁		max. 2 x d ₁	max. 2 x d ₁	max. 2 x d ₁	max. 2 x d ₁		max. 3 x d ₁	Thread Depth and Hole Shape		
P 1.1-4.1		K 1.1-4.2	K 1.1-4.2	K 1.1-4.2	K 1.1-4.2	P 1.1-4.1	P 1.1-4.1	Applications – Material		
M 1.1-3.1		N 1.4-6	N 1.4-6	N 1.4-6	N 1.4-6	K 2.1-2	K 2.1-2			
N 1.4-6						N 1.4-6	N 1.4-6			
N 2.1-2, 2.4-5										
S 1.1										
B0513720								Tool Identification		
Enorm 1-Z/E TIN	Flutes							Dimens. ID	Nominal Size ø d ₁	P
★	3							.0202	M 3 x	0.35
★	3							.0210	M 4 x	0.5
★	3							.0218	M 5 x	0.5
								.0229	M 6 x	0.75
								.0250	M 8 x	0.75
								.0251	M 8 x	1
								.0276	M 10 x	1
								.0277	M 10 x	1.25
C0513720								Tool Identification		
Enorm 2-Z/E TIN	Flutes	Rekord 2A-SPEED IKZ-TICN	Rekord 2A-SPEED IKZN-TICN	Rekord 2A-SPEED/E IKZ-TICN	Rekord 2A-SPEED/E IKZN-TICN	Rekord 2B-Z-SPEED PM-TIN-70	Rekord 2B-Z-SPEED IKZN-PM TIN-70	Dimens. ID	Nominal Size ø d ₁	P
★	3	★	3			★	4	.0251	M 8 x	1
★	4	★	4	upon		★	4	.0276	M 10 x	1
		●	3			★	4	.0277	M 10 x	1.25
★	5	★	4	request	★	4	request	.0303	M 12 x	1.5
★	5	●	4		★	4		.0331	M 14 x	1.5
★	5	●	4		★	4		.0359	M 16 x	1.5
						★	4	.0390	M 18 x	1.5
						★	4	.0422	M 20 x	1.5
								.0438	M 22 x	1.5
								.0439	M 22 x	2
								.0452	M 24 x	1.5
								.0453	M 24 x	2
								.0470	M 27 x	1.5
								.0471	M 27 x	2
								.0490	M 30 x	1.5
								.0491	M 30 x	2

● = In stock
★ = Allow 7 days for delivery

1) Threading in through holes is possible only with external cooling/lubrication

Product
Finder

V_c

UNC

UNF

UNEF

UN-8

MF

NPSM/NPSC

NPSF

R_p (BSPP)

G

NPT

NPTF

Rc (BSPT)

STI

SELF-LOCK

Accessories

Tech. Info



- Product Finder
- V_c
- UNC
- UNF
- UNEF
- UN-8
- M
- MF
- NPSM/NPSC
- NPSF
- Rp (BSPP)
- G
- NPT
- NPTF
- Rc (BSPT)
- STI
- SELF-LOCK
- Accessories
- Tech. Info

DIN Length • DIN Shank

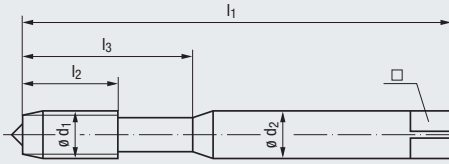

Reinforced Shank
(M3x0.35 - M10x1.25)

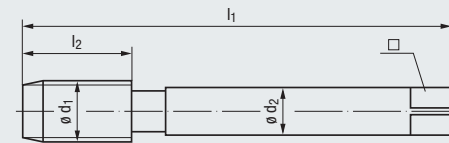

Reduced Shank
(M8x1 - M30x2)

SPEED
High-Speed
Cutting

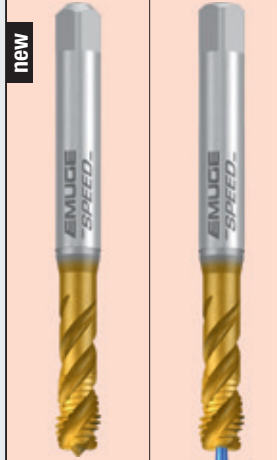

MF

**ISO Metric Fine Thread
DIN 13**

Class of Fit
Coating
Cutting Material
Technical Characteristics

6HX	6HX
TIN-60	TIN-60
HSSE-PM	HSSE-PM
R45	R45
C / 2-3	C / 2-3
E	E

Thread Depth
and Hole Shape

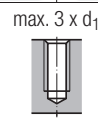

Applications – Material

P 2.1-4.1	P 2.1-4.1
-----------	-----------

Reinforced Shank

Nominal Size ø d ₁	P	mm					□	Tool Identification	
		l ₁	l ₂	l ₃	ø d ₂	Dimens. ID			
M 3 x 0.35	56	4.5	18	3.5	2.7	2.65	.0202		
M 4 x 0.5	63	5	21	4.5	3.4	3.5	.0210		
M 5 x 0.5	70	5	25	6	4.9	4.5	.0218		
M 6 x 0.75	80	8	30	6	4.9	5.2	.0229		
M 8 x 0.75	80	8	30	8	6.2	7.2	.0250		
M 8 x 1	90	10	35	8	6.2	7	.0251		
M 10 x 1	90	10	35	10	8	9	.0276		
M 10 x 1.25	100	16	39	10	8	8.8	.0277		

Reduced Shank

Nominal Size ø d ₁	P	mm					□	Tool Identification		C3600F01		C3650F01	
		l ₁	l ₂	l ₃	ø d ₂	Dimens. ID		Enorm 2-Z-SPEED X-PM TIN-60	Flutes	Enorm 2-Z-SPEED X-1KZ-PM TIN-60	Flutes		
M 8 x 1	90	10	—	6	4.9	7	.0251	★	3	★	3		
M 10 x 1	90	10	—	7	5.5	9	.0276	★	4	★	4		
M 10 x 1.25	100	16	—	7	5.5	8.8	.0277	★	4	★	4		
M 12 x 1.5	100	15	—	9	7	10.5	.0303	★	5	★	5		
M 14 x 1.5	100	15	—	11	9	12.5	.0331	★	5	★	5		
M 16 x 1.5	100	15	—	12	9	14.5	.0359	★	5	★	5		
M 18 x 1.5	110	17	—	14	11	16.5	.0390	★	5	★	5		
M 20 x 1.5	125	17	—	16	12	18.5	.0422	★	5	★	5		
M 22 x 1.5	125	17	—	18	14.5	20.5	.0438						
M 22 x 2	140	20	—	18	14.5	20	.0439						
M 24 x 1.5	140	20	—	18	14.5	22.5	.0452						
M 24 x 2	140	20	—	18	14.5	22	.0453						
M 27 x 1.5	140	20	—	20	16	25.5	.0470						
M 27 x 2	140	20	—	20	16	25	.0471						
M 30 x 1.5	150	22	—	22	18	28.5	.0490						
M 30 x 2	150	22	—	22	18	28	.0491						

DIN Length • DIN Shank

With internal chip collector

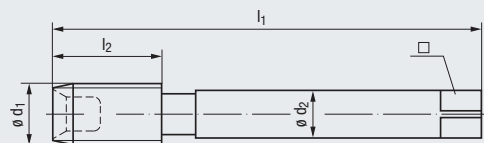

Reduced Shank

VA
Stainless Steel
Materials



MF

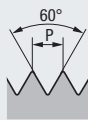

**ISO Metric Fine Thread
DIN 13**

Class of Fit

Coating

Cutting Material

Technical Characteristics



Thread Depth
and Hole Shape

Applications – Material

- 6HX
- NE2
- HSS Extra
- C / 2-3
- P / 0 1)

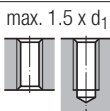

- P 1.1-4.1
- M 1.1-2.1
- K 1.1-4.2

Reduced Shank

Tool Identification

C0803001

Nominal Size ø d ₁	P	l ₁	mm l ₂	ø d ₂	□		Dimens. ID	Robust 2X-VA NE2	
								Flutes	
M 20 x 1.5	125	25	16	12	18.5	.0422	★	5	
M 22 x 1.5	125	25	18	14.5	20.5	.0438	★	5	
M 24 x 1.5	140	27	18	14.5	22.5	.0452	★	5	
M 24 x 2	140	27	18	14.5	22	.0453	★	5	
M 27 x 1.5	140	28	20	16	25.5	.0470	★	5	
M 27 x 2	140	28	20	16	25	.0471	★	5	
M 30 x 1.5	150	28	22	18	28.5	.0490	★	6	
M 33 x 1.5	160	30	25	20	31.5	.0511	★	6	
M 33 x 2	160	30	25	20	31	.0512	★	6	
M 36 x 1.5	170	30	28	22	34.5	.0532	★	6	
M 36 x 2	170	30	28	22	34	.0533	★	6	
M 36 x 3	200	42	28	22	33	.0534	★	6	
M 38 x 1.5	170	30	28	22	36.5	.0546	★	6	
M 39 x 3	200	42	32	24	36	.0555	★	6	
M 40 x 2	170	30	32	24	38	.0561	★	6	
M 42 x 1.5	170	30	32	24	40.5	.0574	★	6	
M 42 x 2	170	30	32	24	40	.0575	★	6	
M 42 x 3	200	45	32	24	39	.0576	★	6	
M 45 x 3	200	45	36	29	42	.0597	★	6	
M 48 x 1.5	190	32	36	29	46.5	.0616	★	8	
M 48 x 2	190	32	36	29	46	.0617	★	7	
M 48 x 3	225	50	36	29	45	.0618	★	6	
M 52 x 3	225	50	40	32	49	.0646	★	6	
M 56 x 3	225	50	40	32	53	.0661	★	7	
M 56 x 4	250	60	40	32	52	.0662	★	7	
M 60 x 4	280	60	45	35	56	.0672	★	7	
M 64 x 3	275	55	50	39	61	.0681	★	8	
M 64 x 4	315	65	50	39	60	.0682	★	7	
M 68 x 4	315	65	50	39	64	.0692	★	7	
M 70 x 3	275	55	50	39	67	.0696	★	8	

● = In stock
★ = Allow 7 days for delivery

- Product Finder
- V_c
- UNC
- UNF
- UNEF
- UN-8
- ...
- MF
- NPSM/NPSC
- NPSF
- R_p (BSPP)
- G
- NPT
- NTF
- R_c (BSPT)
- STI
- SELF-LOCK
- Accessories
- Tech. Info



- Product Finder
- V_c
- UNC
- UNF
- UNEF
- UN-8
- M
- MF
- NPSM/NPSC
- NPSF
- Rp (BSPP)
- G
- NPT
- NPTF
- Rc (BSPT)
- STI
- SELF-LOCK
- Accessories
- Tech. Info

DIN Length • DIN Shank

VA
Stainless Steel
Materials



With internal chip collector

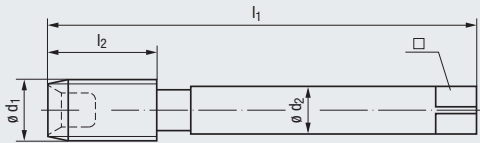

Reduced Shank

MF

ISO Metric Fine Thread
DIN 13

Class of Fit
Coating
Cutting Material
Technical Characteristics

- 6HX
- NE2
- HSS Extra
- C / 2-3
- P / 0 1)

Thread Depth
and Hole Shape

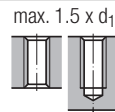

Applications – Material

- P 1.1-4.1
- M 1.1-2.1
- K 1.1-4.2

Reduced Shank

Tool Identification

C0803001

Nominal Size ø d ₁	P	l ₁	mm		□	Image	Dimens. ID	Robust 2X-VA NE2	Flutes
			l ₂	ø d ₂					
M 70 x 4	4	340	65	50	39	66	.0697	★	7
M 72 x 3	3	275	55	50	39	69	.0702	★	8
M 72 x 4	4	340	65	50	39	68	.0703	★	8
M 72 x 6	6	340	80	50	39	66	.0704	★	7
M 76 x 3	3	275	55	50	39	73	.0714	★	8
M 76 x 4	4	340	65	50	39	72	.0715	★	8
M 76 x 6	6	340	80	50	39	70	.0716	★	7
M 80 x 4	4	360	65	50	39	76	.0727	★	10
M 80 x 6	6	360	80	50	39	74	.0728	★	8
M 85 x 3	3	325	60	50	39	82	.0736	★	10
M 85 x 4	4	380	70	50	39	81	.0737	★	10
M 90 x 3	3	325	60	50	39	87	.0746	★	10
M 90 x 4	4	380	70	50	39	86	.0747	★	10
M 90 x 6	6	380	80	50	39	84	.0748	★	9
M 95 x 6	6	400	85	56	44	89	.0758	★	9
M 100 x 4	4	400	70	56	44	96	.0767	★	10
M 100 x 6	6	400	85	56	44	94	.0768	★	10
M 110 x 6	6	400	85	56	44	104	.0788	★	10
M 115 x 3	3	350	65	56	44	112	.0791	★	12
M 120 x 4	4	400	75	56	44	116	.0797	★	12
M 120 x 6	6	400	90	56	44	114	.0798	★	10

≥ M56 Shank with grooves for better handling!

1) If possible, use paste lubrication, coating both the tool and the walls of the drilled hole.
Lubrication with oil is possible only in the vertical machining of blind holes, if the hole is entirely filled with oil.

Larger sizes priced upon request.

The Complete Tool System

Robust 2X-VA Taps when used with a KSN Type tapping attachment creates the optimal tapping unit!

Extra Length • DIN Shank

Z
CNC-Controlled
Machines

Product
Finder

V_c

UNC

UNF

UNEF

UN-8

...

MF

NPSM/NPSC

NPSF

R_p (BSPP)

G

NPT

NPTF

R_c (BSPT)

STI

SELF-LOCK

Accessories

Tech. Info

With long flutes and long shank for thread depths up to max. 4 x d₁

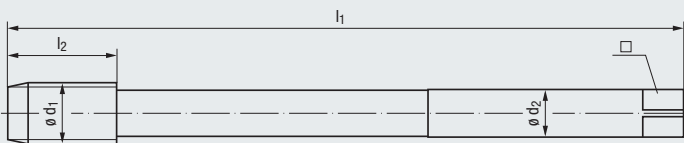

new

new

new



MF

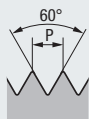

ISO Metric Fine Thread
DIN 13

Class of Fit
Coating
Cutting Material
Technical Characteristics

6HX
TICN
HSS Extra
C / 2-3
E / O

6HX
TIN
HSS Extra
R15
C / 2-3
E / O

6HX
TIN
HSS Extra
R15
C / 2-3
E / O

Thread Depth
and Hole Shape

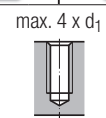
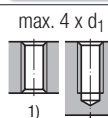

Applications – Material

P 1.1-4.1
K 1.1-4.2
N 1.4-6, 2.4-7
N 4.1

P 2.1-5.1
K 2.1-2
N 1.4-6, 2.4-5

P 2.1-5.1
K 2.1-2
N 1.4-6, 2.4-5

Reduced Shank

Nominal Size ø d ₁	P	l ₁	mm l ₂	ø d ₂	□	Tool Identification		C0539401		C4283701		C4063701	
						Image	Dimens. ID	Rekord 2A-Z- IKZ-LF4 TICN	Flutes	Rekord 2D-Z- IKZ-LF4 TIN	Flutes	Rekord 2D-Z- BF-IKZ-LF4 TIN	Flutes
M 24	x 2	240	20	18	14.5		.0453						
M 30	x 2	270	22	22	18		.0491	upon		upon		upon	
M 36	x 3	310	30	28	22		.0534	request		request		request	

1) Threading in through holes is possible only with external cooling/lubrication

- Product Finder
- V_c
- UNC
- UNF
- UNEF
- UN-8
- M
- MF**
- NPSM/NPSC
- NPSF
- Rp (BSPP)
- G
- NPT
- NPTF
- Rc (BSPT)
- STI
- SELF-LOCK
- Accessories
- Tech. Info

ANSI Length • ANSI Shank

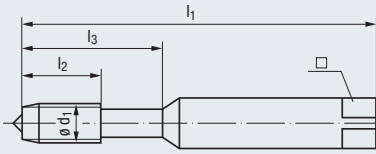

Reinforced Shank
(M10x1 - M10x1.25)

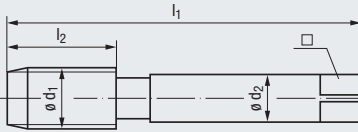

Reduced Shank
(M12x1.5 - M14x1.5)

STEEL Steel Materials

new



new



MF

**ISO Metric Fine Thread
DIN 13**

Class of Fit
Coating
Cutting Material
Technical Characteristics

ISO 2/6H	ISO 2/6H	ISO 2/6H	ISO 2/6H
TIN	TIN	TIN	TIN
HSS Extra	HSS Extra	HSS Extra	HSS Extra
R15	R15	R15	R35
B / 4-5	E / 1.5-2	E / 1.5-2	C / 2-3
E / 0	E / 0	E / 0	E / 0

Thread Depth and Hole Shape

max. 3 x d ₁	max. 2 x d ₁	max. 2 x d ₁	max. 2.5 x d ₁

Applications – Material

P 1.1-4.1	P 2.1-3.1	P 1.1-4.1	P 1.1-4.1
K 2.1		K 1.1-4.2	K 2.1
N 2.2, 2.4-5		N 1.4-5, 2.4-5	N 2.2

Nominal Size ϕd_1	P mm	inch				ϕd_2	□	Tool Identification		AU208400		AU461000		AU461400		AU501400	
		l_1	l_2	l_3	ϕd_2			mm	Dimens. ID	Rekord B-STEEL-L TIN	Flutes	Rekord D-STEEL/E	Flutes	Rekord D-STEEL/E TIN	Flutes	Enorm STEEL TIN	Flutes
M 10 x 1		2 15/16 2.94	0.709	1.378	0.381	0.286	9	.0276	●	4	●	3	●	3	●	3	
M 10 x 1.25		2 15/16 2.94	0.709	1.378	0.381	0.286	8.8	.0277	●	3	●	3	●	3	●	3	
M 12 x 1.5		3 3/8 3.38	0.866	—	0.367	0.275	10.5	.0303	●	3	●	3	●	3	●	4	
M 14 x 1.5		3 19/32 3.59	0.866	—	0.429	0.322	12.5	.0331	●	3	●	3	●	3	●	4	

DIN Length • DIN Shank



All ANSI Length • ANSI Shank taps are available in the popular DIN Length • DIN Shank style.

The DIN Length • DIN Shank configuration allows for added reach capabilities and greater chip clearance.

ANSI Length • ANSI Shank

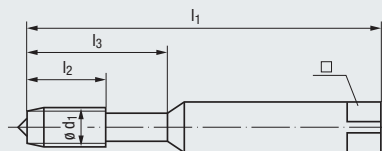

Reinforced Shank
(M10x1 - M10x1.25)

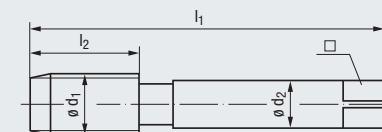

Reduced Shank
(M12x1.5 - M14x1.5)

MF

**ISO Metric Fine Thread
DIN 13**

Class of Fit
Coating
Cutting Material
Technical Characteristics



Thread Depth
and Hole Shape

Applications – Material

Nominal Size ϕd_1	P mm	inch					
		l_1	l_2	l_3	ϕd_2	\square	
M 10 x 1	2 15/16	2.94	0.709	1.378	0.381	0.286	
M 10 x 1.25	2 15/16	2.94	0.709	1.378	0.381	0.286	
M 12 x 1.5	3 3/8	3.38	0.866	—	0.367	0.275	
M 14 x 1.5	3 19/32	3.59	0.866	—	0.429	0.322	

Tool Identification

mm	Dimens. ID	AU203000		AU503000		AU110501		AU110601	
		Rekord B-VA NT	Flutes	Enorm VA	Flutes	Rekord A-H/E NT	Flutes	Rekord A-H/E TIN	Flutes
9	.0276	●	4	●	3	●	4	●	4
8.8	.0277	●	3	●	3	●	3	●	3
10.5	.0303	●	3	●	4	●	4	●	4
12.5	.0331	●	3	●	4	●	4	●	4

VA
Stainless Steel
Materials



H
Materials of High
Tensile Strength



ISO 2/6H
NT
HSS Extra
R35
C / 2-3
E / O / P

max. 3 x d_1

P 1.1-3.1
M 1.1-2.1
K 2.1
N 2.2, 2.5-6

6HX
NT
HSS Extra
E / 1.5-2
E / O / P

max. 2 x d_1

P 1.1-3.1
K 1.1-4.2
N 2.4-7
N 4.1, 5.1

Product Finder

- Vc
- UNC
- UNF
- UNEF
- UN-8
- MF
- NPSM/NPSC
- NPSF
- Rp (BSPP)
- G
- NPT
- NPTF
- Rc (BSPT)
- STI
- SELF-LOCK
- Accessories
- Tech. Info



- Product Finder
- V_c
- UNC
- UNF
- UNEF
- UN-8
- M
- MF
- NPSM/NPSC
- NPSF
- Rp (BSPP)
- G
- NPT
- NPTF
- Rc (BSPT)
- STI
- SELF-LOCK
- Accessories
- Tech. Info

DIN Length • DIN Shank

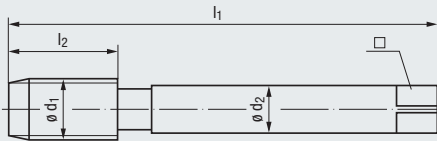

Reduced Shank

STEEL
Steel
Materials



Z
CNC-Controlled
Machines



NPSM/ NPSC

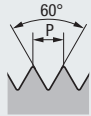

**American Standard Straight Pipe Thread
ANSI B1.20.1**

For mechanical joints (previously NPS)

Class of Fit

"X"

Coating

HSS Extra

Cutting Material

Technical Characteristics



C / 2-3

E / 0

Thread Depth
and Hole Shape

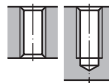

P 1.1-3.1
N 2.3

Applications – Material

max. 3 x d₁



P 1.1-4.1
M 1.1-2.1
N 2.1

P 1.1-4.1
M 1.1-3.1
N 1.4-6
N 2.1-2, 2.4-5
S 1.1

Reduced Shank

Tool Identification

C0101001

C0513500

C0513700

Nominal Size ø d ₁	T.P.I.	ø d ₁	l ₁	mm		□	Tool Identification		Rekord 2A-STEEL	Flutes	Enorm 2-Z/E	Flutes	Enorm 2-Z/E TIN	Flutes	
				l ₂	ø d ₂		NPSM	NPSC							Dimens. ID
1/8	27	10.100	90	18	7	5.5	9.1	8.8	.5858	●	4	●	4	●	4
1/4	18	13.404	100	22	11	9	12	11.4	.5859	●	4	●	5	●	5
3/8	18	16.843	100	22	12	9	15.5	14.9	.5860			●	5	●	5
1/2	14	20.949	125	25	16	12	19	18.4	.5861			●	5	●	5
3/4	14	26.296	140	28	20	16	24.5	23.7	.5862			●	5		
1	11 1/2	32.895	160	30	25	20	30.5	29.8	.5863						

NPSM can also be used for NPSC thread

DIN Length • DIN Shank

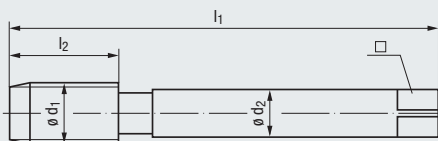

Reduced Shank

STEEL
Steel
Materials



Z
CNC-Controlled
Machines



NPSF
American Standard Straight Pipe Thread
ANSI B1.20.3

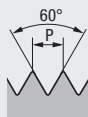

Dryseal internal straight pipe thread for fuel, combined with external tapered pipe thread NPTF or PTF-SAE-SHORT; Gage with tapered gages

Class of Fit: "X"
Coating: HSS Extra
Cutting Material: HSS Extra
Technical Characteristics: C / 2-3, E / O



Thread Depth and Hole Shape: max. 2 x d₁

Applications – Material: P 1.1-3.1, N 2.3

Coating: TIN
Cutting Material: HSS Extra
Technical Characteristics: R45, E / 1.5-2, E / O / P

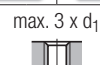

Thread Depth and Hole Shape: max. 3 x d₁

Applications – Material: P 1.1-4.1, M 1.1-2.1, N 2.1, E / 1.5-2, E / O / P, TIN: M 1.1-3.1, N 1.4-6, N 2.1-2, 2.4-5, S 1.1

Reduced Shank

							Tool Identification		C0101001		C0513500		C0513700	
Nominal Size ø d ₁	T.P.I.	ø d ₁	l ₁	mm l ₂	ø d ₂	□	Image	Dimens. ID	Rekord	Flutes	Enorm	Flutes	Enorm	Flutes
									2A-STEEL		2-Z/E		2-Z/E TIN	
1/16	27	7.582	90	17	6	4.9	6.35	.5904	★	3	●	3	●	3
1/8	27	9.929	90	18	7	5.5	8.7	.5905	●	4	●	4	●	4
1/4	18	13.236	100	22	11	9	11.3	.5906	●	4	●	5	●	5
3/8	18	16.673	100	22	12	9	14.75	.5907	●	4	●	5	●	5
1/2	14	20.819	125	25	16	12	18.2	.5908	●	4	●	5	●	5
3/4	14	26.166	140	28	20	16	23.5	.5909	●	4				
1	11 1/2	32.718	160	30	25	20	29.5	.5910						

● = In stock
★ = Allow 7 days for delivery

- Product Finder
- V_c
- UNC
- UNF
- UNEF
- UN-8
- ...
- MF
- NPSM/NPSC
- NPSF**
- R_p (BSPP)
- G
- NPT
- NPTF
- R_c (BSPT)
- STI
- SELF-LOCK
- Accessories
- Tech. Info



- Product Finder
- V_c
- UNC
- UNF
- UNEF
- UN-8
- M
- MF
- NPSM/NPSC
- NPSF
- Rp (BSPP)
- G
- NPT
- NPTF
- Rc (BSPT)
- STI
- SELF-LOCK
- Accessories
- Tech. Info

DIN Length • DIN Shank

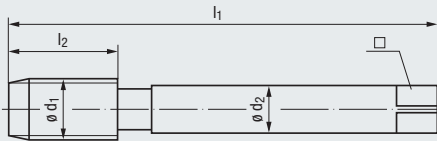

Reduced Shank

STEEL
Steel
Materials



Z
CNC-Controlled
Machines



new

Rp (BSPP)

**Cylindrical Whitworth Pipe Thread
DIN EN 10226-1 and ISO 7-1**

Where pressure-tight joints are made on the threads

Class of Fit: "X"
Coating: HSS Extra
Cutting Material: HSS Extra
Technical Characteristics: C / 2-3, E / 0

Thread Depth and Hole Shape: max. 2 x d₁

Applications – Material: P 1.1-3.1, N 2.3

CNC-Controlled Machines: HSS Extra, R45, E / 1.5-2, E / 0 / P

max. 3 x d₁

Applications – Material: P 1.1-4.1, M 1.1-2.1, N 2.1, E / 0 / P

Reduced Shank

Nominal Size ø d ₁	T.P.I.	ø d ₁	l ₁	mm		ø d ₂	□	Tool Identification		C0101001		C0513500		C0513700	
				l ₂	□			Rekord 2A-STEEL	Flutes	Enorm 2-Z/E	Flutes	Enorm 2-Z/E TIN	Flutes		
Rp 1/8	28	9.73	90	18	7	5.5	8.6	.4092	★	4	●	4	★	4	
Rp 1/4	19	13.16	100	22	11	9	11.5	.4093	★	4	●	5	★	5	
Rp 3/8	19	16.66	100	22	12	9	15	.4094	★	4	●	5	★	5	
Rp 1/2	14	20.96	125	25	16	12	18.5	.4095	★	4	●	5	★	5	
Rp 3/4	14	26.44	140	28	20	16	24	.4096	★	4	●	5			
Rp 1	11	33.25	160	30	25	20	30.25	.4097	★	5	●	6			

DIN Length • DIN Shank

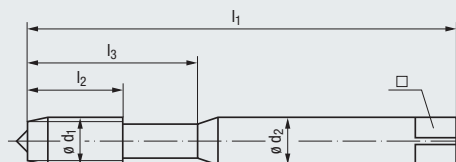

Reinforced Shank

HCUT
Hardened
Steels



2)

G
Whitworth Pipe Thread
DIN EN ISO 228

Class of Fit: "X"
Coating: TiCN
Cutting Material: **HSSE-PM** / **Carbide** / **Carbide**
Technical Characteristics: C / 2-3, D / 4-5, C / 2-3
 O / P, O / P, O / P

Thread Depth and Hole Shape

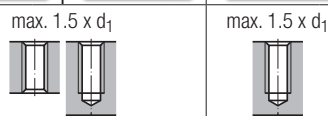

Applications – Material

H 1.1-2, H 1.3-4, H 1.3-4

Reinforced Shank

Nominal Size ø d ₁	T.P.I.	mm						□	Tool Identification		B010J901	B016K101	B010K101
		ø d ₁	l ₁	l ₂	l ₃	ø d ₂	□		Dimens. ID	Rekord 1A-HCUT-PM TiCN	VHM Rekord 1A-HCUT/D TiCN	VHM Rekord 1A-HCUT/C TiCN	
G 1/8	28	9.73	90	10	35	10	8	8.8	.4035	★	5		
G 1/8	28	9.73	100	18	38	10	8	8.8	.4035		★	5	★
G 1/4	19	13.16	110	24	44	14	11	11.9	.4036		★	6	★

2) Please note: Use solid carbide tap VHM-Rekord 1A-HCUT/D-TiCN as No.1 tap!

- Product Finder
- V_c
- UNC
- UNF
- UNEF
- UN-8
- ...
- MF
- NPSM/NPSC
- NPSF
- R_p (BSPP)
- G**
- NPT
- NPTF
- R_c (BSPT)
- STI
- SELF-LOCK
- Accessories
- Tech. Info



- Product Finder
- V_c
- UNC
- UNF
- UNEF
- UN-8
- M
- MF
- NPSM/NPSC
- NPSF
- Rp (BSPP)
- G**
- NPT
- NPTF
- Rc (BSPT)
- STI
- SELF-LOCK
- Accessories
- Tech. Info

DIN Length • DIN Shank

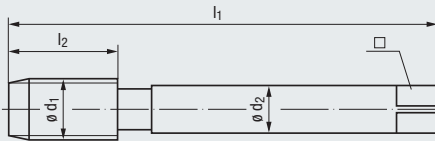

Reduced Shank

STEEL Steel Materials



G 

**Whitworth Pipe Thread
DIN EN ISO 228**

Class of Fit: "X"
 Coating: HSS Extra
 Cutting Material: HSS Extra
 Technical Characteristics: C / 2-3, E / 0

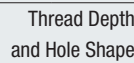

Thread Depth and Hole Shape

Applications – Material

Coating: HSS Extra	Coating: HSS Extra	Coating: TIN HSS Extra	Coating: HSS Extra	Coating: HSS Extra
Technical Characteristics: C / 2-3, E / 0	Technical Characteristics: B / 4-5, E / 0	Technical Characteristics: B / 4-5, E / 0	Technical Characteristics: R15, C / 2-3, E / 0	Technical Characteristics: R15, E / 1.5-2, E / 0
Thread Depth and Hole Shape: max. 2 x d ₁	Thread Depth and Hole Shape: max. 3 x d ₁	Thread Depth and Hole Shape: max. 3 x d ₁	Thread Depth and Hole Shape: max. 2 x d ₁	Thread Depth and Hole Shape: max. 2 x d ₁
Applications – Material: P 1.1-3.1, N 2.3	Applications – Material: P 1.1-3.1, N 2.2	Applications – Material: P 1.1-4.1, K 2.1, N 2.2, 2.4-5	Applications – Material: P 2.1-3.1	Applications – Material: P 2.1-3.1

Reduced Shank

Nominal Size ø d ₁	T.P.I.	ø d ₁	l ₁	mm		ø d ₂	□	Tool Identification		C0101001		C0208900		C0208400		C0451000		C0461000	
				l ₂	□			Rekord 2A-STEEL	Flutes	Rekord 2B-STEEL-L	Flutes	Rekord 2B-STEEL-L TIN	Flutes	Rekord 2D-STEEL	Flutes	Rekord 2D-STEEL/E	Flutes		
G 1/16	28	7.72	90	17	6	4.9	6.8	.4034	★	3									
G 1/8	28	9.73	90	18	7	5.5	8.8	.4035	★	4	★	3	★	3	★	3	★	3	★
G 1/4	19	13.16	100	22	11	9	11.8	.4036	★	4	★	3	★	3	★	3	★	3	★
G 3/8	19	16.66	100	22	12	9	15.25	.4037	★	4	★	3	★	3	★	3	★	3	★
G 1/2	14	20.96	125	25	16	12	19	.4038	★	4	★	4	★	4	★	4	★	4	★
G 5/8	14	22.91	125	25	18	14.5	21	.4039			★	4							
G 3/4	14	26.44	140	28	20	16	24.5	.4040	★	4	★	4	★	4	★	4	★	4	★
G 7/8	14	30.20	150	28	22	18	28.25	.4041											
G 1	11	33.25	160	30	25	20	30.75	.4042	★	5	★	4	★	4	★	4	★	4	★
G 1 1/8	11	37.90	170	30	28	22	35.5	.4043			★	5							
G 1 1/4	11	41.91	170	30	32	24	39.5	.4044	★	6	★	6							
G 1 3/8	11	44.32	180	32	36	29	41.75	.4045			★	6							
G 1 1/2	11	47.80	190	32	36	29	45.25	.4046	★	6	★	6							
G 1 5/8	11	52.00	190	32	40	32	49.5	.4047			★	6							
G 1 3/4	11	53.75	190	32	40	32	51	.4048			★	6							
G 2	11	59.61	220	40	45	35	57	.4050			★	8							

STEEL Steel Materials				VA Stainless Steel Materials				H Materials of High Tensile Strength				Tool Identification		
Enorm 2-STEEL		Enorm 2-STEEL TIN		Rekord 2B-VA NT		Enorm 2-VA GLT-1		Rekord 2A-H NT		Rekord 2A-H TICN		Dimens. ID	Nominal Size $\varnothing d_1$	T.P.I.
Flutes	Flutes	Flutes	Flutes	Flutes	Flutes	Flutes	Flutes	Flutes	Flutes	Flutes	Flutes			
★	3	★	3	★	3	★	3	★	4	★	4	.4034	G 1/16	28
★	4	★	4	★	3	★	3	★	4	★	4	.4035	G 1/8	28
★	4	★	4	★	3	★	3	★	4	★	4	.4036	G 1/4	19
★	4	★	4	★	4	★	4	★	4	★	4	.4037	G 3/8	19
												.4038	G 1/2	14
												.4039	G 5/8	14
												.4040	G 3/4	14
												.4041	G 7/8	14
												.4042	G 1	11
												.4043	G 1 1/8	11
												.4044	G 1 1/4	11
												.4045	G 1 3/8	11
												.4046	G 1 1/2	11
												.4047	G 1 5/8	11
												.4048	G 1 3/4	11
												.4050	G 2	11

Product Finder

Vc

UNC

UNF

UNEF

UN-8

MF

NPSM/NPSC

NPSF

Rp (BSPP)

G

NPT

NPTF

Rc (BSPT)

STI

SELF-LOCK

Accessories

Tech. Info



● = In stock
★ = Allow 7 days for delivery

- Product Finder
- V_c
- UNC
- UNF
- UNEF
- UN-8
- M
- MF
- NPSM/NPSC
- NPSF
- Rp (BSPP)
- G**
- NPT
- NPTF
- Rc (BSPT)
- STI
- SELF-LOCK
- Accessories
- Tech. Info

DIN Length • DIN Shank

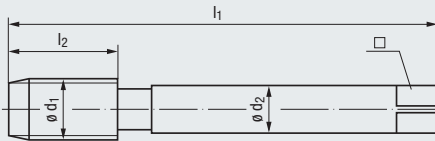

Reduced Shank

H
Materials of High Tensile Strength



HCUT
Hardened Steels



2)

G

Whitworth Pipe Thread
DIN EN ISO 228

Class of Fit
Coating
Cutting Material
Technical Characteristics



Thread Depth and Hole Shape

Applications – Material

- "X"
- Carbide
- E / 1.5-2
- E / 0

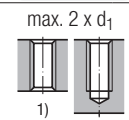

- P 5.1
- K 1.1-4.2
- N 1.5-6, 2.6-8
- N 4.1, 4.3-5.2
- H 1.1-2

- "X"
- TICN
- HSSE-PM
- C / 2-3
- O / P

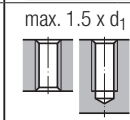

H 1.1-2

Reduced Shank

Nominal Size ø d ₁	T.P.I.	ø d ₁	l ₁	mm			□	Tool Identification		VHM/KHM Rekord 2A-H/E-IKZ	Flutes	C010J901	
				l ₂	ø d ₂	□		Rekord 2A-HCUT-PM TICN	Flutes				
G 1/16	28	7.72	90	10	6	4.9	6.8	.4034					
G 1/8	28	9.73	90	10	7	5.5	8.8	.4035	★	4	★	5	
G 1/4	19	13.16	100	15	11	9	11.8 2)	.4036	★	4	★	6	
G 3/8	19	16.66	100	15	12	9	15.25 2)	.4037	★	4	★	6	
G 1/2	14	20.96	125	17	16	12	19 2)	.4038	★	4	★	6	

1) Threading in through holes is possible only with external cooling/lubrication
 2) Increase drill diameter for taps Rekord 1/2A-HCUT-PM-TICN from G 1/4 by 0.1 mm

DIN Length • DIN Shank

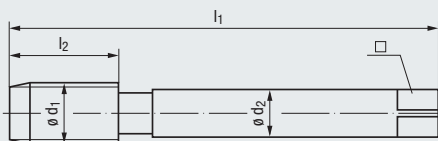

Reduced Shank

Z
CNC-Controlled
Machines



G
Whitworth Pipe Thread
DIN EN ISO 228

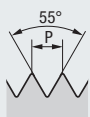

Class of Fit
Coating
Cutting Material
Technical Characteristics



Coating	TIN
Cutting Material	HSS Extra
Technical Characteristics	R45
	E / 1.5-2
	E / O / P

Thread Depth
and Hole Shape

max. 3 x d₁



Applications – Material

P 1.1-4.1	P 1.1-4.1
M 1.1-2.1	M 1.1-3.1
N 2.1	N 1.4-6
	N 2.1-2, 2.4-5
	S 1.1

Reduced Shank

Tool Identification

C0513500

C0513700

Nominal Size ø d ₁	T.P.I.	ø d ₁	l ₁	mm l ₂	ø d ₂	□	Image	Dimens. ID	C0513500		C0513700	
									Enorm 2-Z/E	Flutes	Enorm 2-Z/E TIN	Flutes
G 1/16	28	7.72	90	10	6	4.9		.4034				
G 1/8	28	9.73	90	10	7	5.5		.4035	★	4	●	4
G 1/4	19	13.16	100	15	11	9	11.8	.4036	★	5	●	5
G 3/8	19	16.66	100	15	12	9	15.25	.4037	★	5	●	5
G 1/2	14	20.96	125	17	16	12	19	.4038	★	5	★	5
G 5/8	14	22.91	125	17	18	14.5	21	.4039				
G 3/4	14	26.44	140	20	20	16	24.5	.4040	★	5	★	5
G 7/8	14	30.20	150	22	22	18	28.25	.4041				
G 1	11	33.25	160	24	25	20	30.75	.4042	★	6	★	6
G 1 1/8	11	37.90	170	24	28	22	35.5	.4043				
G 1 1/4	11	41.91	170	25	32	24	39.5	.4044				
G 1 3/8	11	44.32	180	27	36	29	41.75	.4045				
G 1 1/2	11	47.80	190	27	36	29	45.25	.4046				
G 1 5/8	11	52.00	190	27	40	32	49.5	.4047				
G 1 3/4	11	53.75	190	27	40	32	51	.4048				
G 2	11	59.61	220	32	45	35	57	.4050				

- Product Finder
- V_c
- UNC
- UNF
- UNEF
- UN-8
- ...
- MF
- NPSM/NPSC
- NPSF
- R_p (BSPP)
- G**
- NPT
- NTF
- R_c (BSPT)
- STI
- SELF-LOCK
- Accessories
- Tech. Info



● = In stock
★ = Allow 7 days for delivery

- Product Finder
- V_c
- UNC
- UNF
- UNEF
- UN-8
- M
- MF
- NPSM/NPSC
- NPSF
- Rp (BSPP)
- G**
- NPT
- NPTF
- Rc (BSPT)
- STI
- SELF-LOCK
- Accessories
- Tech. Info

DIN Length • DIN Shank

VA
Stainless Steel
Materials



With internal chip collector

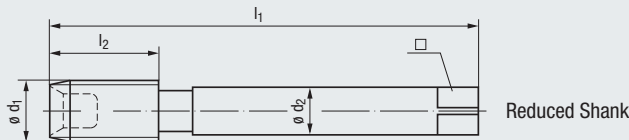

G

Whitworth Pipe Thread
DIN EN ISO 228

Class of Fit	"X"
Coating	NE2
Cutting Material	HSS Extra
Technical Characteristics	C / 2-3
	P / O 1)
Thread Depth and Hole Shape	max. 1.5 x d ₁
Applications – Material	P 1.1-4.1 M 1.1-2.1 K 1.1-4.2

Reduced Shank

Tool Identification

C0803001

Nominal Size ø d ₁	T.P.I.	ø d ₁	l ₁	inch		ø d ₂	□	Image	Dimens. ID	Robust 2X-VA NE2	Flutes
				l ₂	ø d ₂						
G 1	11	33.25	160	30	25	20		30.75	.4042	★	6
G 1 1/4	11	41.91	170	30	32	24		39.5	.4044	★	6
G 1 1/2	11	47.80	190	32	36	29		45.25	.4046	★	6
G 1 3/4	11	53.75	190	32	40	32		51	.4048	★	7
G 2	11	59.61	220	40	45	35		57	.4050	★	8
G 2 1/4	11	65.71	275	45	50	39		63.3	.4051	★	8
G 2 1/2	11	75.18	275	45	50	39		72.8	.4053	★	8
G 2 3/4	11	81.53	325	50	50	39		79.1	.4054	★	10
G 3	11	87.88	325	50	50	39		85.5	.4055	★	10

≥ G2 Shank with grooves for better handling!

1) If possible, use paste lubrication, coating both the tool and the walls of the drilled hole.
Lubrication with oil is possible only in the vertical machining of blind holes, if the hole is entirely filled with oil.

Larger sizes priced upon request.

The Complete Tool System

Robust 2X-VA Taps when used with a KSN Type tapping attachment creates the optimal tapping unit!

Extra Length • ANSI Shank

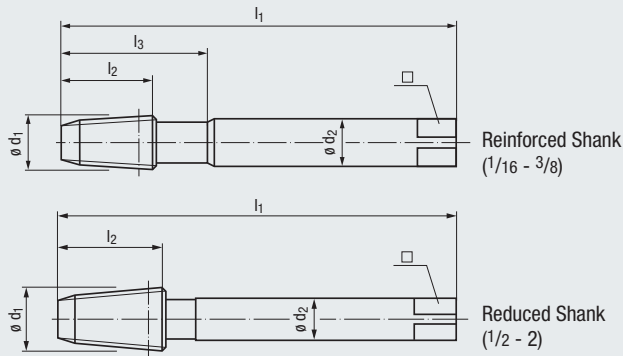

NPT
 American Tapered Pipe Thread,
 ANSI/ASME B1.20.1
 For threads with dryseal material,
 taper 1:16

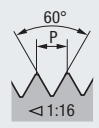

Class of Fit
 Coating
 Cutting Material
 Technical Characteristics
 Applications – Material



Steel Materials	VA Stainless Steel Materials
TIN	TIN
HSS Extra	HSS Extra
C / 2-3	C / 2-3
E / O	E / O
P 1.1-2.1	P 1.1-3.1
K 1.1-2	M 1.1-3.1
N 2.2-3	M 1.1-3.1

Tool Identification	CW181000	CW181400	CW483000	CW483100
---------------------	----------	----------	----------	----------

Nominal Size $\varnothing d_1$	T.P.I.	l_1	l_2	inch l_3	$\varnothing d_2$	\square	Dimens. ID	Rekord 2A-STEEL		Rekord 2A-STEEL TIN		Rekord 2D-VA		Rekord 2D-VA TIN	
								Flutes	Flutes	Flutes	Flutes	Flutes	Flutes		
1/16	27	3.543	0.69	1.161	0.3125	0.234	.5763	●	4	●	4	●	3	●	3
1/8	27	3.937	0.75	1.299	0.4375	0.328	.5764	●	5	●	5	●	3	●	3
1/4	18	3.937	1.06	1.772	0.5625	0.421	.5765	●	5	●	5	●	3	●	3
3/8	18	4.331	1.06	1.850	0.7000	0.531	.5766	●	5	●	5	●	3	●	3
1/2	14	5.512	1.38	—	0.6875	0.515	.5767	●	5	●	5	●	5	●	5
3/4	14	5.512	1.38	—	0.9063	0.679	.5768	●	6	●	6	●	5	●	5
1	11 1/2	6.299	1.75	—	1.1250	0.843	.5769	●	6	●	6				
1 1/4	11 1/2	6.693	1.75	—	1.3125	0.984	.5770	●	6	●	6				
1 1/2	11 1/2	7.480	1.75	—	1.5000	1.125	.5771	●	7	●	7				
2	11 1/2	7.874	1.75	—	1.8750	1.406	.5772	●	7	●	7				

Taper reamers for taper holes 1:16, see page 118.

Thread Hole Preparatory Diameters for Tapered Pipe Thread NPT, Taper 1:16

A) Cylindrical preparation of thread hole

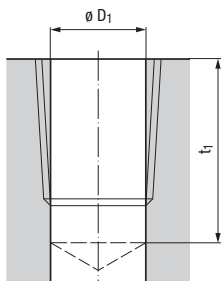

B) Tapered preparation of thread hole

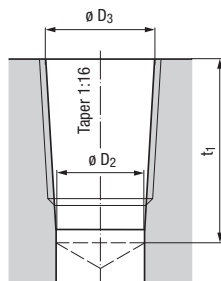

Nominal Size $\varnothing d_1$	T.P.I.	inch			
		$\varnothing D_1$	$\varnothing D_2$	$\varnothing D_3$ (+0.002)	t_1
1/16	27	0.2421	0.2343	0.2516	0.4646
1/8	27	0.3346	0.3268	0.3441	0.4685
1/4	18	0.4331	0.4232	0.4472	0.6850
3/8	18	0.5669	0.5571	0.5827	0.6969
1/2	14	0.7008	0.6870	0.7213	0.9094
3/4	14	0.9114	0.8976	0.9319	0.9291
1	11 1/2	1.1437	1.1280	1.1689	1.1181
1 1/4	11 1/2	1.4882	1.4705	1.5138	1.1378
1 1/2	11 1/2	1.7264	1.7106	1.7528	1.1378
2	11 1/2	2.1988	2.1831	2.2268	1.1535

The minimum drilling depth t_1 includes the reach of screw by hand L_1 and the effective depth L_3 to ANSI/ASME B1.20.1 as well as the chamfer of the tap. Additional drilling-down has to be determined by the user according to the construction of the workpiece. For series production it is recommended that the minor thread dia. be made as per B. Special taps are required for blind holes where the minimum depths t_1 as listed in the above table cannot be met. In this case please supply a sketch with blind hole dimensions along with the order.

● = In stock
 ★ = Allow 7 days for delivery

- Product Finder
- Vc
- UNC
- UNF
- UNEF
- UN-8
- M
- MF
- NPSM/NPSC
- NPSF
- Rp (BSPP)
- G
- NPT**
- NPTF
- Rc (BSPT)
- STI
- SELF-LOCK
- Accessories
- Tech. Info

Extra Length - ANSI Shank

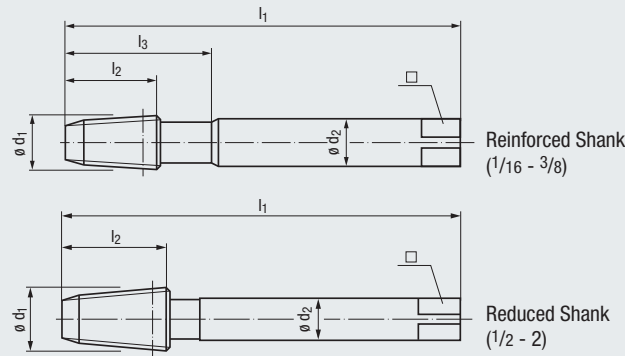

VA
Stainless Steel
Materials



NPT

**American Tapered Pipe Thread,
ANSI/ASME B1.20.1**

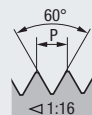

For threads with dryseal material,
taper 1:16

Class of Fit
Coating
Cutting Material
Technical Characteristics

Applications – Material

	TIN
HSS Extra	HSS Extra
R15	R15
C / 2-3	C / 2-3
E / 0	E / 0

P 1.1-3.1	P 1.1-3.1
M 1.1-3.1	M 1.1-3.1

Tool Identification

CW493000 CW493100

Nominal Size ø d ₁	T.P.I.	l ₁	l ₂	inch l ₃	ø d ₂	□	Dimens. ID	Rekord 2D-VA-AZ		Rekord 2D-VA-AZ TIN	
								Flutes	Flutes	Flutes	Flutes
1/16	27	3.543	0.69	1.161	0.3125	0.234	.5763	●	3	●	3
1/8	27	3.937	0.75	1.299	0.4375	0.328	.5764	●	3	●	3
1/4	18	3.937	1.06	1.772	0.5625	0.421	.5765	●	3	●	3
3/8	18	4.331	1.06	1.850	0.7000	0.531	.5766	●	3	●	3
1/2	14	5.512	1.38	—	0.6875	0.515	.5767	●	5	●	5
3/4	14	5.512	1.38	—	0.9063	0.679	.5768	●	5	●	5
1	11 1/2	6.299	1.75	—	1.1250	0.843	.5769				
1 1/4	11 1/2	6.693	1.75	—	1.3125	0.984	.5770				
1 1/2	11 1/2	7.480	1.75	—	1.5000	1.125	.5771				
2	11 1/2	7.874	1.75	—	1.8750	1.406	.5772				

Taper reamers for taper holes 1:16, see page 118

Thread Hole Preparatory Diameters for Tapered Pipe Thread NPT, Taper 1:16

A) Cylindrical preparation of thread hole

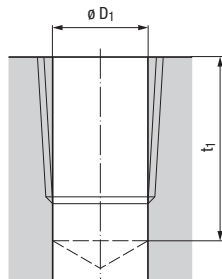

B) Tapered preparation of thread hole

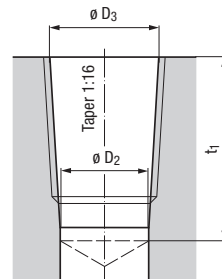

Nominal Size ø d ₁	T.P.I.	inch			t ₁
		ø D ₁	ø D ₂	ø D ₃ (+0.002)	
1/16	27	0.2421	0.2343	0.2516	0.4646
1/8	27	0.3346	0.3268	0.3441	0.4685
1/4	18	0.4331	0.4232	0.4472	0.6850
3/8	18	0.5669	0.5571	0.5827	0.6969
1/2	14	0.7008	0.6870	0.7213	0.9094
3/4	14	0.9114	0.8976	0.9319	0.9291
1	11 1/2	1.1437	1.1280	1.1689	1.1181
1 1/4	11 1/2	1.4882	1.4705	1.5138	1.1378
1 1/2	11 1/2	1.7264	1.7106	1.7528	1.1378
2	11 1/2	2.1988	2.1831	2.2268	1.1535

The minimum drilling depth t₁ includes the reach of screw by hand L₁ and the effective depth L₃ to ANSI/ASME B1.20.1 as well as the chamfer of the tap. Additional drilling-down has to be determined by the user according to the construction of the workpiece. For series production it is recommended that the minor thread dia. be made as per B. Special taps are required for blind holes where the minimum depths t₁ as listed in the above table cannot be met. In this case please supply a sketch with blind hole dimensions along with the order.

ANSI Length • ANSI Shank

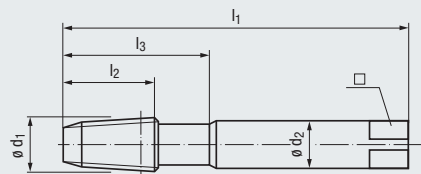

Reinforced Shank
(1/16 - 3/8)

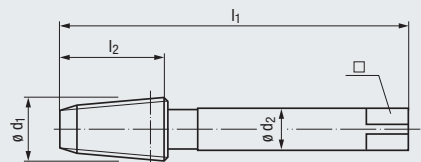

Reduced Shank
(1/2 - 2)

NPT

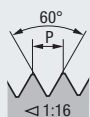

**American Tapered Pipe Thread,
ANSI/ASME B1.20.1**

For threads with dryseal material,
taper 1:16

Class of Fit
Coating
Cutting Material
Technical Characteristics

Applications – Material

Tool Identification

STEEL
Steel
Materials

VA
Stainless Steel
Materials

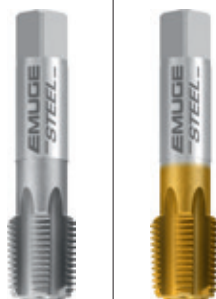

	TIN		TIN
HSS Extra	HSS Extra	HSS Extra	HSS Extra
C / 2-3	C / 2-3	C / 2-3	C / 2-3
E / 0	E / 0	E / 0	E / 0
P 1.1-2.1 K 1.1-2 N 2.2-3	P 1.1-2.1 K 1.1-2 N 2.2-3	P 1.1-4.1 M 1.1-3.1 K 2.1-4.2 N 2.4-6	P 1.1-4.1 M 1.1-3.1 K 2.1-4.2 N 2.4-6

Nominal Size ø d ₁	T.P.I.	inch						Dimens. ID	AW181000		AW181400		AW193000		AW193100	
		l ₁	l ₂	l ₃	ø d ₂	□	Rekord A-STEEL		Flutes	Rekord A-STEEL TIN	Flutes	Rekord A-VA-AZ	Flutes	Rekord A-VA-AZ TIN	Flutes	
1/16	27	2 1/8	2.13	0.69	0.925	0.3125	0.234	.5763	●	4	●	4	●	3	●	3
1/8	27	2 1/8	2.13	0.75	0.984	0.4375	0.328	.5764	●	5	●	5	●	3	●	3
1/4	18	2 7/16	2.44	1.06	1.280	0.5625	0.421	.5765	●	5	●	5	●	3	●	3
3/8	18	2 9/16	2.56	1.06	1.339	0.7000	0.531	.5766	●	5	●	5	●	3	●	3
1/2	14	3 1/8	3.13	1.38	—	0.6875	0.515	.5767	●	5	●	5	●	5	●	5
3/4	14	3 1/4	3.25	1.38	—	0.9063	0.679	.5768	●	6	●	6	●	5	●	5
1	11 1/2	3 3/4	3.75	1.75	—	1.1250	0.843	.5769	●	6	●	6	●	5	●	5
1 1/4	11 1/2	4	4.00	1.75	—	1.3125	0.984	.5770	●	6	●	6				
1 1/2	11 1/2	4 1/4	4.25	1.75	—	1.5000	1.125	.5771	●	7	●	7				
2	11 1/2	4 1/2	4.50	1.75	—	1.8750	1.406	.5772	●	7	●	7				

- Product Finder
- Vc
- UNC
- UNF
- UNEF
- UN-8
- ...
- MF
- NPSM/NPSC
- NPSF
- Rp (BSPP)
- G
- NPT
- NPTF
- Rc (BSPT)
- STI
- SELF-LOCK
- Accessories
- Tech. Info



Taper reamers for taper holes 1:16, see page 118

● = In stock
★ = Allow 7 days for delivery

- Product Finder
- Vc
- UNC
- UNF
- UNEF
- UN-8
- M
- MF
- NPSM/NPSG
- NPSF
- Rp (BSPP)
- G
- NPT**
- NPTF
- Rc (BSPT)
- STI
- SELF-LOCK
- Accessories
- Tech. Info

ANSI Length • ANSI Shank

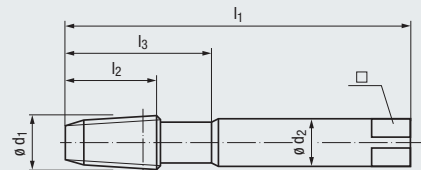

Reinforced Shank
(1/16 - 3/8)

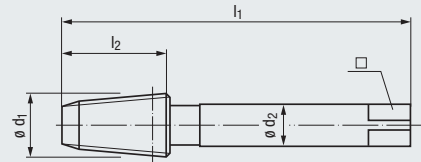

Reduced Shank
(1/2 - 2)



NPT American Tapered Pipe Thread, ANSI/ASME B1.20.1

For threads with dryseal material,
taper 1:16

Class of Fit
Coating
Cutting Material
Technical Characteristics

Applications – Material

VA Stainless Steel Materials



Coating	TIN	TICN	HSS Extra	HSS Extra
Class of Fit	HSS Extra	HSS Extra	HSS Extra	HSS Extra
Coating	R15	R15	R15	R15
Cutting Material	C / 2-3	C / 2-3	C / 2-3	C / 2-3
Technical Characteristics	E / 0	E / 0	E / 0	E / 0
Applications – Material	P 1.1-3.1 M 1.1-3.1	P 1.1-3.1 M 1.1-3.1	P 1.1-3.1 M 1.1-3.1	P 1.1-3.1 M 1.1-3.1

Nominal Size ø d ₁	T.P.I.	inch						Dimens. ID	AW483000		AW483100		AW889300		AW493000		AW493100	
		l ₁	l ₂	l ₃	ø d ₂	□	Rekord D-VA		Flutes	Rekord D-VA TIN	Flutes	Rekord D-VA-1KZN TICN	Flutes	Rekord D-VA-AZ	Flutes	Rekord D-VA-AZ TIN	Flutes	
1/16	27	2 1/8	2.13	0.69	0.925	0.3125	0.234	.5763	●	3	●	3	●	3	●	3	●	3
1/8	27	2 1/8	2.13	0.75	0.984	0.4375	0.328	.5764	●	3	●	3	●	3	●	3	●	3
1/4	18	2 7/16	2.44	1.06	1.280	0.5625	0.421	.5765	●	3	●	3	●	3	●	3	●	3
3/8	18	2 9/16	2.56	1.06	1.339	0.7000	0.531	.5766	●	3	●	3	●	3	●	3	●	3
1/2	14	3 1/8	3.13	1.38	—	0.6875	0.515	.5767	●	5	●	5	●	5	●	5	●	5
3/4	14	3 1/4	3.25	1.38	—	0.9063	0.679	.5768	●	5	●	5	●	5	●	5	●	5
1	11 1/2	3 3/4	3.75	1.75	—	1.1250	0.843	.5769	●	5	●	5	●	5	●	5	●	5
1 1/4	11 1/2	4	4.00	1.75	—	1.3125	0.984	.5770	●	5	●	5	●	5	●	5	●	5
1 1/2	11 1/2	4 1/4	4.25	1.75	—	1.5000	1.125	.5771	●	5	●	5	●	5	●	5	●	5
2	11 1/2	4 1/2	4.50	1.75	—	1.8750	1.406	.5772	●	7	●	7	●	7	●	7	●	7

Taper reamers for taper holes 1:16, see page 118

Thread Hole Preparatory Diameters for Tapered Pipe Thread NPT, Taper 1:16

A) Cylindrical preparation of thread hole

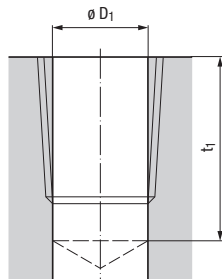

B) Tapered preparation of thread hole

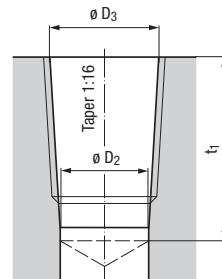

Nominal Size ø d ₁	T.P.I.	ø D ₁	ø D ₂	inch ø D ₃ (+0.002)	t ₁
1/16	27	0.2421	0.2343	0.2516	0.4646
1/8	27	0.3346	0.3268	0.3441	0.4685
1/4	18	0.4331	0.4232	0.4472	0.6850
3/8	18	0.5669	0.5571	0.5827	0.6969
1/2	14	0.7008	0.6870	0.7213	0.9094
3/4	14	0.9114	0.8976	0.9319	0.9291
1	11 1/2	1.1437	1.1280	1.1689	1.1181
1 1/4	11 1/2	1.4882	1.4705	1.5138	1.1378
1 1/2	11 1/2	1.7264	1.7106	1.7528	1.1378
2	11 1/2	2.1988	2.1831	2.2268	1.1535

The minimum drilling depth t₁ includes the reach of screw by hand L₁ and the effective depth L₃ to ANSI/ASME B1.20.1 as well as the chamfer of the tap. Additional drilling-down has to be determined by the user according to the construction of the workpiece. For series production it is recommended that the minor thread dia. be made as per B. Special taps are required for blind holes where the minimum depths t₁ as listed in the above table cannot be met. In this case please supply a sketch with blind hole dimensions along with the order.

ANSI Length • ANSI Shank

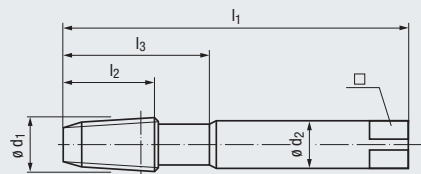

Reinforced Shank
(1/16 - 3/8)

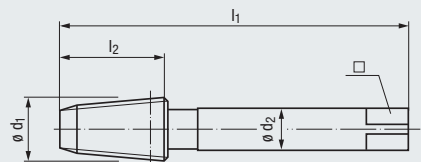

Reduced Shank
(1/2 - 2)

NI
Nickel
Alloys



NPT

**American Tapered Pipe Thread,
ANSI/ASME B1.20.1**

For threads with dryseal material,
taper 1:16

Class of Fit

Coating

Cutting Material

Technical Characteristics



Applications – Material

- TICN
- HSSE-PM**
- R10
- C / 2-3
- O / P

- M 2.1-4.1**
- S 2.3, 2.5-6**

Tool Identification

AW79J400

Nominal Size ø d ₁	T.P.I.	inch						Dimens. ID	Rekord D-R10-NI TICN	Flutes
		l ₁	l ₂	l ₃	ø d ₂	□				
1/16	27	2 1/8	2.13	0.69	0.925	0.3125	0.234	.5763	●	3
1/8	27	2 1/8	2.13	0.75	0.984	0.4375	0.328	.5764	●	3
1/4	18	2 7/16	2.44	1.06	1.280	0.5625	0.421	.5765	●	3
3/8	18	2 9/16	2.56	1.06	1.339	0.7000	0.531	.5766	●	4
1/2	14	3 1/8	3.13	1.38	—	0.6875	0.515	.5767	●	4
3/4	14	3 1/4	3.25	1.38	—	0.9063	0.679	.5768	●	4
1	11 1/2	3 3/4	3.75	1.75	—	1.1250	0.843	.5769	●	4
1 1/4	11 1/2	4	4.00	1.75	—	1.3125	0.984	.5770	●	6
1 1/2	11 1/2	4 1/4	4.25	1.75	—	1.5000	1.125	.5771	●	6
2	11 1/2	4 1/2	4.50	1.75	—	1.8750	1.406	.5772	●	6

- Product Finder
- V_c
- UNC
- UNF
- UNEF
- UN-8
- ...
- MF
- NPSM/NPSC
- NPSF
- Rp (BSPP)
- G
- NPT**
- NPTF
- Rc (BSPT)
- STI
- SELF-LOCK
- Accessories
- Tech. Info



Taper reamers for taper holes 1:16, see page 118

● = In stock
★ = Allow 7 days for delivery

- Product Finder
- Vc
- UNC
- UNF
- UNEF
- UN-8
- M
- MF
- NPSM/NPSC
- NPSF
- Rp (BSPP)
- G
- NPT
- NPTF
- Rc (BSPT)
- STI
- SELF-LOCK
- Accessories
- Tech. Info

Extra Length - ANSI Shank

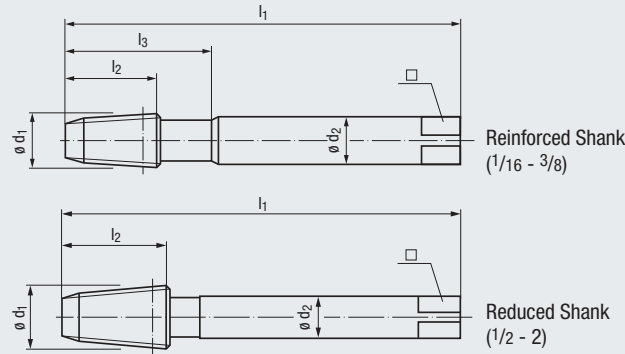

STEEL Steel Materials



VA Stainless Steel Materials



NPTF



American Tapered Pipe Thread, ANSI/ASME B1.20.3

For threads **without dryseal material**,
taper 1:16

Class of Fit
Coating
Cutting Material
Technical Characteristics

Applications – Material

	TIN		TIN
HSS Extra	HSS Extra	HSS Extra	HSS Extra
C / 2-3	C / 2-3	C / 2-3	C / 2-3
E / 0	E / 0	E / 0	E / 0
P 1.1-2.1	P 1.1-2.1	P 1.1-4.1	P 1.1-4.1
K 1.1-2	K 1.1-2	M 1.1-3.1	M 1.1-3.1
N 2.2-3	N 2.2-3	K 2.1-4.2	K 2.1-4.2
		N 2.4-6	N 2.4-6

Nominal Size $\varnothing d_1$	T.P.I.	l_1	l_2	inch l_3	$\varnothing d_2$	\square	Dimens. ID	Tool Identification		Rekord 2A-VA-AZ	Rekord 2A-VA-AZ TIN	Rekord 2A-VA-AZ	Rekord 2A-VA-AZ TIN
								CW181000	CW181400				
								Rekord 2A-STEEL	Flutes	Rekord 2A-STEEL	Flutes	Rekord 2A-VA-AZ	Flutes
1/16	27	3.543	0.69	1.161	0.3125	0.234	.5782	●	4	●	4	●	3
1/8	27	3.937	0.75	1.299	0.4375	0.328	.5783	●	5	●	5	●	3
1/4	18	3.937	1.06	1.772	0.5625	0.421	.5784	●	5	●	5	●	3
3/8	18	4.331	1.06	1.850	0.7000	0.531	.5785	●	5	●	5	●	3
1/2	14	5.512	1.38	—	0.6875	0.515	.5786	●	5	●	5	●	5
3/4	14	5.512	1.38	—	0.9063	0.679	.5787	●	6	●	6	●	5
1	11 1/2	6.299	1.75	—	1.1250	0.843	.5788	●	6	●	6	●	5
1 1/4	11 1/2	6.693	1.75	—	1.3125	0.984	.5789	●	6	●	6	●	5
1 1/2	11 1/2	7.480	1.75	—	1.5000	1.125	.5790	●	7	●	7	●	5
2	11 1/2	7.874	1.75	—	1.8750	1.406	.5791	●	7	●	7	●	5

Taper reamers for taper holes 1:16, see page 118

Thread Hole Preparatory Diameters for Tapered Pipe Thread NPTF, Taper 1:16

A) Cylindrical preparation of thread hole

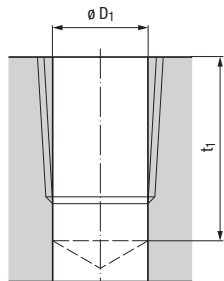

B) Tapered preparation of thread hole

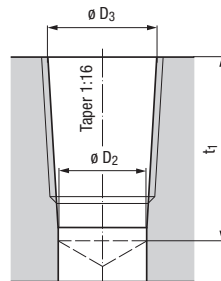

Nominal Size $\varnothing d_1$	T.P.I.	$\varnothing D_1$	$\varnothing D_2$	inch $\varnothing D_3$ (+0.002)	t_1
1/16	27	0.2402	0.2343	0.2524	0.4646
1/8	27	0.3327	0.3268	0.3449	0.4685
1/4	18	0.4291	0.4232	0.4488	0.6850
3/8	18	0.5630	0.5571	0.5843	0.6969
1/2	14	0.6929	0.6870	0.7217	0.9094
3/4	14	0.9055	0.8976	0.9323	0.9291
1	11 1/2	1.1319	1.1280	1.1701	1.1181
1 1/4	11 1/2	1.4764	1.4705	1.5150	1.1378
1 1/2	11 1/2	1.7224	1.7106	1.7539	1.1378
2	11 1/2	2.1949	2.1831	2.2280	1.1535

The minimum drilling depth t_1 includes the reach of screw by hand L_1 and the effective depth L_3 to ANSI B1.20.3 as well as the chamfer of the tap. Additional drilling-down has to be determined by the user according to the construction of the workpiece. For series production it is recommended that the minor thread dia. be made as per B. Special taps are required for blind holes where the minimum depths t_1 as listed in the above table cannot be met. In this case please supply a sketch with blind hole dimensions along with the order.

ANSI Length • ANSI Shank

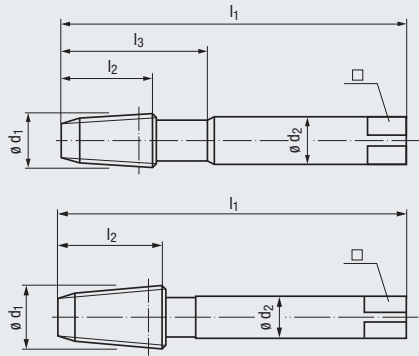

Reinforced Shank
(1/16 - 3/8)

Reduced Shank
(1/2 - 2)

NPTF

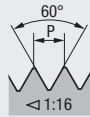

**American Tapered Pipe Thread,
ANSI/ASME B1.20.3**

For threads **without dryseal material**,
taper 1:16

Class of Fit
Coating
Cutting Material
Technical Characteristics

Applications – Material

Tool Identification



Class of Fit				
Coating		TIN		TIN
Cutting Material	HSS Extra	HSS Extra	HSS Extra	HSS Extra
Technical Characteristics	C / 2-3	C / 2-3	C / 2-3	C / 2-3
	E / 0	E / 0	E / 0	E / 0
Applications – Material	P 1.1-2.1 K 1.1-2 N 2.2-3	P 1.1-2.1 K 1.1-2 N 2.2-3	P 1.1-4.1 M 1.1-3.1 K 2.1-4.2 N 2.4-6	P 1.1-4.1 M 1.1-3.1 K 2.1-4.2 N 2.4-6
Tool Identification	AW181000	AW181400	AW193000	AW193100

Nominal Size ϕd_1	T.P.I.	inch						Dimens. ID	AW181000		AW181400		AW193000		AW193100	
		l_1	l_2	l_3	ϕd_2	\square	Rekord A-STEEL		Flutes	Rekord A-STEEL TIN	Flutes	Rekord A-VA-AZ	Flutes	Rekord A-VA-AZ TIN	Flutes	
1/16	27	2 1/8	2.13	0.69	0.925	0.3125	0.234	.5782	●	4	●	4	●	3	●	3
1/8	27	2 1/8	2.13	0.75	0.984	0.4375	0.328	.5783	●	5	●	5	●	3	●	3
1/4	18	2 7/16	2.44	1.06	1.280	0.5625	0.421	.5784	●	5	●	5	●	3	●	3
3/8	18	2 9/16	2.56	1.06	1.339	0.7000	0.531	.5785	●	5	●	5	●	3	●	3
1/2	14	3 1/8	3.13	1.38	—	0.6875	0.515	.5786	●	5	●	5	●	5	●	5
3/4	14	3 1/4	3.25	1.38	—	0.9063	0.679	.5787	●	6	●	6	●	5	●	5
1	11 1/2	3 3/4	3.75	1.75	—	1.1250	0.843	.5788	●	6	●	6	●	5	●	5
1 1/4	11 1/2	4	4.00	1.75	—	1.3125	0.984	.5789	●	6	●	6	●	5	●	5
1 1/2	11 1/2	4 1/4	4.25	1.75	—	1.5000	1.125	.5790	●	7	●	7	●	5	●	5
2	11 1/2	4 1/2	4.50	1.75	—	1.8750	1.406	.5791	●	7	●	7	●	7	●	7



Taper reamers for taper holes 1:16, see page 118

● = In stock
★ = Allow 7 days for delivery

Product Finder

- Vc
- UNC
- UNF
- UNEF
- UN-8
- ...
- MF
- NPSM/NPSC
- NPSF
- Rp (BSPP)
- G
- NPT
- NPTF
- Rc (BSPT)
- STI
- SELF-LOCK
- Accessories
- Tech. Info



- Product Finder
- Vc
- UNC
- UNF
- UNEF
- UN-8
- M
- MF
- NPSM/NPSC
- NPSF
- Rp (BSPP)
- G
- NPT
- NPTF
- Rc (BSPT)
- STI
- SELF-LOCK
- Accessories
- Tech. Info

ANSI Length • ANSI Shank

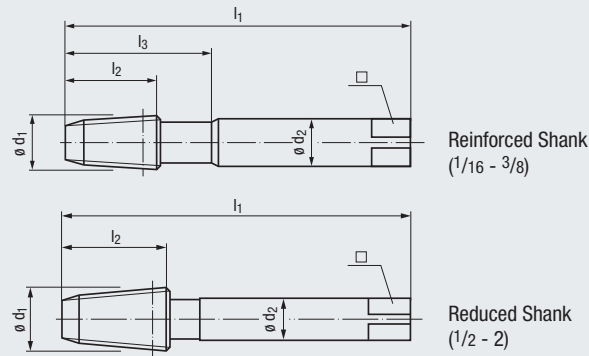

NPTF

American Tapered Pipe Thread, ANSI/ASME B1.20.3

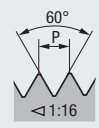

For threads **without dryseal material**, taper 1:16

Class of Fit
Coating
Cutting Material
Technical Characteristics
Applications – Material

VA Stainless Steel Materials



HSS Extra	TIN	TICN	HSS Extra	TIN
R15	HSS Extra	HSS Extra	R15	HSS Extra
C / 2-3	R15	R15	C / 2-3	R15
E / 0	C / 2-3	C / 2-3	E / 0	C / 2-3
P 1.1-3.1	E / 0	E / 0	P 1.1-3.1	E / 0
M 1.1-3.1	P 1.1-3.1	P 1.1-3.1	M 1.1-3.1	P 1.1-3.1

Nominal Size ø d ₁	T.P.I.	inch						Dimens. ID	Tool Identification		AW483000		AW483100		AW889300		AW493000		AW493100	
		l ₁	l ₂	l ₃	ø d ₂	□	Rekord D-VA		Flutes	Rekord D-VA TIN	Flutes	Rekord D-VA-1KZN TICN	Flutes	Rekord D-VA-AZ	Flutes	Rekord D-VA-AZ TIN	Flutes			
1/16	27	2 1/8	2.13	0.69	0.925	0.3125	0.234	.5782	●	3	●	3	●	3	●	3	●	3	●	3
1/8	27	2 1/8	2.13	0.75	0.984	0.4375	0.328	.5783	●	3	●	3	●	3	●	3	●	3	●	3
1/4	18	2 7/16	2.44	1.06	1.280	0.5625	0.421	.5784	●	3	●	3	●	3	●	3	●	3	●	3
3/8	18	2 9/16	2.56	1.06	1.339	0.7000	0.531	.5785	●	3	●	3	●	3	●	3	●	3	●	3
1/2	14	3 1/8	3.13	1.38	—	0.6875	0.515	.5786	●	5	●	5	●	5	●	5	●	5	●	5
3/4	14	3 1/4	3.25	1.38	—	0.9063	0.679	.5787	●	5	●	5	●	5	●	5	●	5	●	5
1	11 1/2	3 3/4	3.75	1.75	—	1.1250	0.843	.5788	●	5	●	5	●	5	●	5	●	5	●	5
1 1/4	11 1/2	4	4.00	1.75	—	1.3125	0.984	.5789	●	5	●	5	●	5	●	5	●	5	●	5
1 1/2	11 1/2	4 1/4	4.25	1.75	—	1.5000	1.125	.5790	●	5	●	5	●	5	●	5	●	5	●	5
2	11 1/2	4 1/2	4.50	1.75	—	1.8750	1.406	.5791	●	7	●	7	●	7	●	7	●	7	●	7

Taper reamers for taper holes 1:16, see page 118

Thread Hole Preparatory Diameters for Tapered Pipe Thread NPTF, Taper 1:16

A) Cylindrical preparation of thread hole

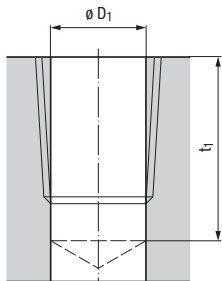

B) Tapered preparation of thread hole

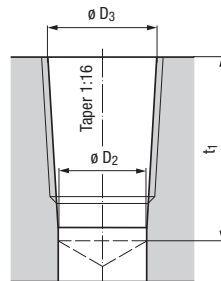

Nominal Size ø d ₁	T.P.I.	ø D ₁	ø D ₂	inch ø D ₃ (+0.002)	t ₁
1/16	27	0.2402	0.2343	0.2524	0.4646
1/8	27	0.3327	0.3268	0.3449	0.4685
1/4	18	0.4291	0.4232	0.4488	0.6850
3/8	18	0.5630	0.5571	0.5843	0.6969
1/2	14	0.6929	0.6870	0.7217	0.9094
3/4	14	0.9055	0.8976	0.9323	0.9291
1	11 1/2	1.1319	1.1280	1.1701	1.1181
1 1/4	11 1/2	1.4764	1.4705	1.5150	1.1378
1 1/2	11 1/2	1.7224	1.7106	1.7539	1.1378
2	11 1/2	2.1949	2.1831	2.2280	1.1535

The minimum drilling depth t₁ includes the reach of screw by hand L₁ and the effective depth L₃ to ANSI B1.20.3 as well as the chamfer of the tap. Additional drilling-down has to be determined by the user according to the construction of the workpiece. For series production it is recommended that the minor thread dia. be made as per B. Special taps are required for blind holes where the minimum depths t₁ as listed in the above table cannot be met. In this case please supply a sketch with blind hole dimensions along with the order.

ANSI Length • ANSI Shank

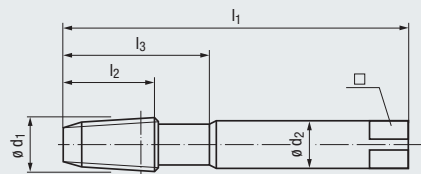

Reinforced Shank
(1/16 - 3/8)

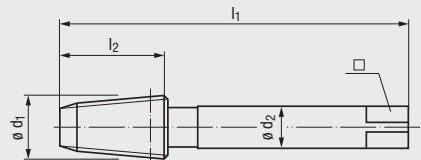

Reduced Shank
(1/2 - 2)

NI
Nickel
Alloys



NPTF

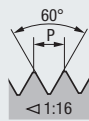

**American Tapered Pipe Thread,
ANSI/ASME B1.20.3**

For threads **without dryseal material**,
taper 1:16

Class of Fit

Coating

Cutting Material

Technical Characteristics



Applications – Material

- TICN
- HSSE-PM**
- R10
- C / 2-3
- O / P

- M 2.1-4.1**
- S 2.3, 2.5-6**

Tool Identification

AW79J400

Nominal Size ϕd_1	T.P.I.	inch						Dimens. ID	Rekord D-R10-NI TICN	Flutes
		l_1	l_2	l_3	ϕd_2	\square	ϕd_2			
1/16	27	2 1/8	2.13	0.69	0.925	0.3125	0.234	.5782	●	3
1/8	27	2 1/8	2.13	0.75	0.984	0.4375	0.328	.5783	●	3
1/4	18	2 7/16	2.44	1.06	1.280	0.5625	0.421	.5784	●	3
3/8	18	2 9/16	2.56	1.06	1.339	0.7000	0.531	.5785	●	4
1/2	14	3 1/8	3.13	1.38	—	0.6875	0.515	.5786	●	4
3/4	14	3 1/4	3.25	1.38	—	0.9063	0.679	.5787	●	4
1	11 1/2	3 3/4	3.75	1.75	—	1.1250	0.843	.5788	●	4
1 1/4	11 1/2	4	4.00	1.75	—	1.3125	0.984	.5789	●	6
1 1/2	11 1/2	4 1/4	4.25	1.75	—	1.5000	1.125	.5790	●	6
2	11 1/2	4 1/2	4.50	1.75	—	1.8750	1.406	.5791	●	6

- Product Finder
- V_c
- UNC
- UNF
- UNEF
- UN-8
- ...
- MF
- NPSM/NPSC
- NPSF
- R_p (BSPP)
- G
- NPT
- NPTF**
- R_c (BSPT)
- STI
- SELF-LOCK
- Accessories
- Tech. Info



Taper reamers for taper holes 1:16, see page 118

● = In stock
★ = Allow 7 days for delivery

- Product Finder
- Vc
- UNC
- UNF
- UNEF
- UN-8
- M
- MF
- NPSM/NPSC
- NPSF
- Rp (BSPP)
- G
- NPT
- NPTF
- Rc (BSPT)
- STI
- SELF-LOCK
- Accessories
- Tech. Info

DIN Length • DIN Shank

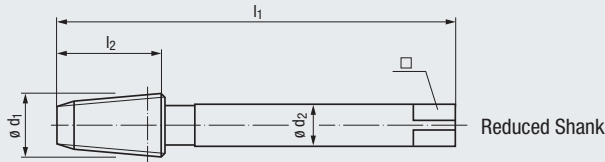

VA
Stainless Steel
Materials

new



RC (BSPT)



Tapered Whitworth Pipe Thread, DIN EN ISO 10226-2 and ISO 7-1

Where pressure-tight joints are made on the threads, taper 1:16

Class of Fit

Coating

Cutting Material

Technical Characteristics



Applications – Material

HSS Extra

C / 2-3

E / 0

P 1.1-4.1

M 1.1-2.1

K 2.1-4.2

N 1.4-5, 2.4-6

Tool Identification C0183000

Nominal Size ø d ₁	T.P.I.	l ₁	l ₂	mm		□	Dimens. ID	Rekord 2A-VA	Flutes
				ø d ₂					
Rc 1/4	19	100	18	11	9		.4116	★	3
Rc 3/8	19	110	18	14	11		.4117	★	5
Rc 1/2	14	140	23	16	12		.4118	★	5
Rc 3/4	14	150	24	20	16		.4119	★	5
Rc 1	11	170	30	25	20		.4120	★	7

Taper reamers for taper holes 1:16, see page 118

Thread Hole Preparatory Diameters for Tapered Pipe Thread Rc (BSPT), Taper 1:16

A) Cylindrical preparation of thread hole

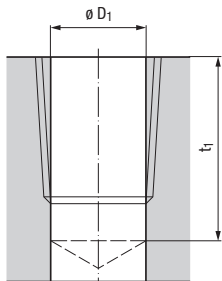

B) Tapered preparation of thread hole

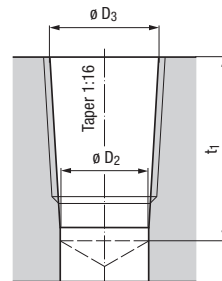

Nominal Size ø d ₁	T.P.I.	mm			t ₁
		ø D ₁	ø D ₂	ø D ₃ (JS11)	
Rc 1/16	28	6.15	6.10	6.56	11.1
Rc 1/8	28	8.15	8.10	8.57	11.1
Rc 1/4	19	10.85	10.75	11.45	16.3
Rc 3/8	19	14.30	14.25	14.95	16.7
Rc 1/2	14	17.80	17.70	18.63	22.3
Rc 3/4	14	23.20	23.10	24.12	23.6
Rc 1	11	29.20	29.10	30.29	28.3

The minimum drilling depth t₁ includes the reach of screw by hand L₁ and the effective depth L₃ to DIN EN ISO 10226-2 and ISO 7-1 as well as the chamfer of the tap. Additional drilling-down has to be determined by the user according to the construction of the workpiece. For series production it is recommended that the minor thread dia. be made as per B. Special taps are required for blind holes where the minimum depths t₁ as listed in the above table cannot be met. In this case please supply a sketch with blind hole dimensions along with the order.

DIN Length • DIN Shank

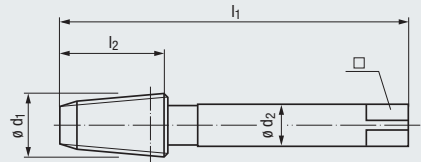

Reduced Shank

STEEL
Steel
Materials



Rc (BSPT)

Tapered Whitworth Pipe Thread,
DIN EN ISO 10226-2 and ISO 7-1

Where pressure-tight joints
are made on the threads,
taper 1:16



Class of Fit
Coating
Cutting Material
Technical Characteristics

HSS Extra

C / 2-3

E / O

Applications – Material

P 1.1-2.1

K 1.1-2

N 2.2-3

Tool Identification

A0181000

Nominal Size ø d ₁	T.P.I.	l ₁	l ₂	mm			Dimens. ID	Rekord A-STEEL	Flutes
				ø d ₂	□				
Rc 1/16	28	63	12	6	4.9	.4114	★	4	
Rc 1/8	28	63	12	7	5.5	.4115	★	5	
Rc 1/4	19	63	18	11	9	.4116	★	5	
Rc 3/8	19	70	18	12	9	.4117	★	5	
Rc 1/2	14	80	23	16	12	.4118	★	5	
Rc 3/4	14	100	24	20	16	.4119	★	6	
Rc 1	11	110	30	25	20	.4120	★	6	

Product Finder

V_c

UNC

UNF

UNEF

UN-8

...

MF

NPSM/NPSC

NPSF

Rp (BSPP)

G

NPT

NPTF

Rc (BSPT)

STI

SELF-LOCK

Accessories

Tech. Info



Taper reamers for taper holes 1:16, see page 118

- Product Finder
- V_c
- UNC
- UNF
- UNEF
- UN-8
- M
- MF
- NPSM/NPSC
- NPSF
- Rp (BSPP)
- G
- NPT
- NPTF
- Rc (BSPT)
- STI
- SELF-LOCK
- Accessories
- Tech. Info

For the Preparation of a Tapered Hole

For tapered pipe threads NPT, NPTF, Rc (BSPT), taper 1:16

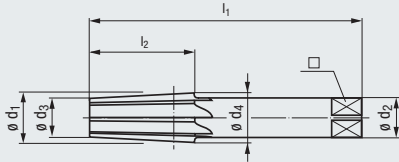

								Cutting Material		Technical Characteristics				
								HSS Extra		HSS Extra				
								L7						
								Tool Identification		G0037165		G0037175		
								KEG-RB 1:16 Form A		KEG-RB 1:16 Form B				
								Flutes		Flutes				
Nominal Size	Ø d ₁	Ø d ₃	Ø d ₄	l ₁	l ₂	Ø d ₂	□	Dimens. ID						
		(-0.05)		mm										
1/16	5.95	7.0	70	17	6	4.9		.5763	★	6	★	6		
1/8	8.05	9.1	70	17	7	5.5		.5764	★	6	★	6		
1/4	10.30	12.0	80	27	11	9		.5765	★	6	★	6		
3/8	13.75	15.4	85	27	12	9		.5766	★	8	★	8		
1/2	16.95	19.1	95	35	16	12		.5767	★	8	★	8		
3/4	22.25	24.5	105	35	20	16		.5768	★	10	★	10		
1	28.00	30.7	130	43	25	20		.5769	★	10	★	10		
1 1/4	36.75	39.5	140	44	32	24		.5770	★	12	★	12		
1 1/2	42.80	45.6	150	45	36	29		.5771	★	12	★	12		
2	54.80	57.7	160	46	45	35		.5772	★	14	★	14		

Please note: If needed, the reamers can be fitted to the required hole depth by shortening the cutting part.

DIN Length • ANSI Shank

Overall length acc. to DIN 371, DIN 376

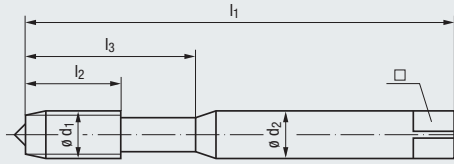

Reinforced Shank
(STI-No.2 - STI 5/16)

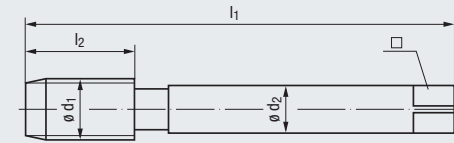

Reduced Shank
(STI 3/8 - STI 1)

STI-UNC

Unified Coarse Thread
ASME B18.29.1

For wire thread inserts



Class of Fit
Coating
Cutting Material
Technical Characteristics



Thread Depth
and Hole Shape

Applications – Material



3B	3B	3B	3B
NT	GLT-1	GLT-8	GLT-8
HSS Extra	HSS Extra	HSS Extra	HSS Extra
B / 4-5	B / 4-5	B / approx. 3	E / 1.5-2
E / O / P	E / O / P	E / O	E / O
max. 3 x d ₁		max. 3 x d ₁	max. 2.5 x d ₁
P 1.1-3.1	P 1.1-4.1	N 1.1-4	N 1.1-4
M 1.1-2.1	M 1.1-3.1		
K 2.1	K 2.1		
N 2.2, 2.5-6	N 2.2		

Reinforced Shank

Nominal Size ø d ₁	T.P.I.	inch						□	Tool Identification		BU203010		BU20C310		BU20S810		BU51S810	
		ø d ₁	l ₁	l ₂	l ₃	ø d ₂	□		Rekord 1B-VA NT	Flutes	Rekord 1B-VA GLT-1	Flutes	Rekord 1B-AL GLT-8	Flutes	Enorm 1-AL/E GLT-8	Flutes		
STI-No. 2	56	0.1092	2.205	0.433	0.709	0.141	0.110	0.0906	.5609	●	3	●	3	●	2	●	2	
STI-No. 4	40	0.1445	2.205	0.472	0.787	0.141	0.110	0.1220	.5611	●	3	●	3	●	2	●	2	
STI-No. 5	40	0.1575	2.480	0.512	0.827	0.168	0.131	0.1339	.5612	●	3	●	3	●	2	●	2	
STI-No. 6	32	0.1786	2.756	0.512	0.984	0.194	0.152	0.1496	.5613	●	3	●	3	●	2	●	2	
STI-No. 8	32	0.2046	3.150	0.512	1.142	0.220	0.165	0.1732	.5614	●	3	●	3	●	2	●	2	
STI-No. 10	24	0.2441	3.150	0.669	1.181	0.255	0.191	0.2047	.5615	●	3	●	3	●	2	●	2	
STI-No. 12	24	0.2701	3.543	0.669	1.260	0.318	0.238	0.2283	.5616	●	3	●	3	●	2	●	2	
STI 1/4	20	0.3150	3.543	0.787	1.378	0.318	0.238	0.2638	.5617	●	3	●	3	●	2	●	2	
STI 5/16	18	0.3847	3.937	0.866	1.535	0.381	0.286	0.3307	.5618	●	3	●	3	●	3	●	2	

Reduced Shank

Nominal Size ø d ₁	T.P.I.	inch						□	Tool Identification		CU203010		CU20C310		CU20S810		CU51S810	
		ø d ₁	l ₁	l ₂	l ₃	ø d ₂	□		Rekord 2B-VA NT	Flutes	Rekord 2B-VA GLT-1	Flutes	Rekord 2B-AL GLT-8	Flutes	Enorm 2-AL/E GLT-8	Flutes		
STI 3/8	16	0.4562	3.937	0.866	—	0.367	0.275	0.3937	.5619	●	3	●	3	●	3	●	3	
STI 7/16	14	0.5303	4.331	1.024	—	0.429	0.322	0.4567	.5620	●	3	●	3	●	3	●	3	
STI 1/2	13	0.5999	4.331	1.063	—	0.480	0.360	0.5236	.5621	●	3	●	3	●	3	●	3	
STI 9/16	12	0.6708	4.921	1.024	—	0.542	0.406	0.5866	.5622	●	3	●	3	●	3	●	3	
STI 5/8	11	0.7431	4.921	1.181	—	0.590	0.442	0.6496	.5623	●	3	●	3	●	3	●	3	
STI 3/4	10	0.8799	5.512	1.260	—	0.697	0.523	0.7776	.5624	●	3	●	3	●	3	●	3	
STI 7/8	9	1.0193	6.299	1.417	—	0.800	0.600	0.9055	.5625	●	3	●	3	●	3	●	3	
STI 1	8	1.1624	7.087	1.575	—	1.021	0.766	1.0335	.5626	●	3	●	4	●	3	●	3	

● = In stock
★ = Allow 7 days for delivery

Product Finder

- V_c
- UNC
- UNF
- UNEF
- UN-8
- MF
- NPSM/NPSC
- NPSF
- R_p (BSPP)
- G
- NPT
- NPTF
- R_c (BSPT)
- STI
- SELF-LOCK
- Accessories
- Tech. Info



- Product Finder
- V_c
- UNC
- UNF
- UNEF
- UN-8
- M
- MF
- NPSM/NPSC
- NPSF
- Rp (BSPP)
- G
- NPT
- NPTF
- Rc (BSPT)
- STI
- SELF-LOCK
- Accessories
- Tech. Info

DIN Length - ANSI Shank

Overall length acc. to DIN 371, DIN 376

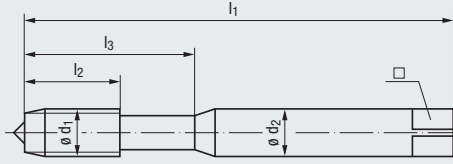

Reinforced Shank
(STI-No.2 - STI 5/16)

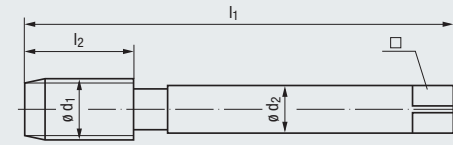

Reduced Shank
(STI 3/8 - STI 1)

TI
Titanium



Z
CNC-Controlled
Machines



STI-UNC

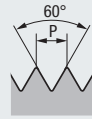

Unified Coarse Thread
ASME B18.29.1

For wire thread inserts

Class of Fit: **3BX**
Coating: **NT2**
Cutting Material: **HSS Extra**
Technical Characteristics: **R15**
C / 2-3
E / O / P

Thread Depth and Hole Shape: max. 2 x d₁



Applications - Material

- P 4.1-5.1**
- M 3.1-4.1**
- N 2.4-5, 2.7**
- S 1.1-2.2, 2.4**

Class of Fit: **3B**
Coating: **HSS Extra**
Cutting Material: **R45**
Technical Characteristics: **E / 1.5-2**
E / O / P

Class of Fit: **3B**
Coating: **TIN**
Cutting Material: **HSS Extra**
Technical Characteristics: **R45**
E / 1.5-2
E / O / P

Class of Fit: **3B**
Coating: **GLT-1**
Cutting Material: **HSS Extra**
Technical Characteristics: **R45**
E / 1.5-2
E / O / P

Thread Depth and Hole Shape: max. 3 x d₁



- P 1.1-4.1**
- M 1.1-2.1**
- N 2.1**

- P 1.1-4.1**
- M 1.1-3.1**
- N 1.4-6**
- N 2.1-2, 2.4-5**
- S 1.1**

- P 1.1-4.1**
- M 1.1-3.1**
- N 1.4-6**
- N 2.1-2, 2.4-5**
- S 1.1**

Reinforced Shank

										Tool Identification		BU456011		BU513510		BU513710		BU51C410	
Nominal Size ø d ₁	T.P.I.	ø d ₁	l ₁	inch			ø d ₂	□	Rekord ID	Rekord 1D-TI NT2	Flutes	Enorm 1-Z/E	Flutes	Enorm 1-Z/E TIN	Flutes	Enorm 1-Z/E GLT-1	Flutes		
				l ₂	l ₃	ø d ₂													
STI-No. 2	56	0.1092	2.205	0.433	0.709	0.141	0.110	0.0906	.5609	●	3	●	2	●	3	●	3		
STI-No. 4	40	0.1445	2.205	0.472	0.787	0.141	0.110	0.1220	.5611	●	3	●	3	●	3	●	3		
STI-No. 5	40	0.1575	2.480	0.512	0.827	0.168	0.131	0.1339	.5612	●	3	●	3	●	3	●	3		
STI-No. 6	32	0.1786	2.756	0.512	0.984	0.194	0.152	0.1496	.5613	●	3	●	3	●	3	●	3		
STI-No. 8	32	0.2046	3.150	0.512	1.142	0.220	0.165	0.1732	.5614	●	3	●	3	●	3	●	3		
STI-No. 10	24	0.2441	3.150	0.669	1.181	0.255	0.191	0.2047	.5615	●	3	●	3	●	3	●	3		
STI-No. 12	24	0.2701	3.543	0.669	1.260	0.318	0.238	0.2283	.5616	●	3	●	3	●	3	●	3		
STI 1/4	20	0.3150	3.543	0.787	1.378	0.318	0.238	0.2638	.5617	●	3	●	3	●	3	●	3		
STI 5/16	18	0.3847	3.937	0.866	1.535	0.381	0.286	0.3307	.5618	●	3	●	3	●	3	●	3		

Reduced Shank

										Tool Identification		CU456011		CU513510		CU513710		CU51C410	
Nominal Size ø d ₁	T.P.I.	ø d ₁	l ₁	inch			ø d ₂	□	Rekord ID	Rekord 2D-TI NT2	Flutes	Enorm 2-Z/E	Flutes	Enorm 2-Z/E TIN	Flutes	Enorm 2-Z/E GLT-1	Flutes		
				l ₂	l ₃	ø d ₂													
STI 3/8	16	0.4562	3.937	0.866	—	0.367	0.275	0.3937	.5619	●	3	●	5	●	5	●	5		
STI 7/16	14	0.5303	4.331	1.024	—	0.429	0.322	0.4567	.5620	●	3	●	4	●	4	●	4		
STI 1/2	13	0.5999	4.331	1.063	—	0.480	0.360	0.5236	.5621	●	3	●	4	●	4	●	4		
STI 9/16	12	0.6708	4.921	1.024	—	0.542	0.406	0.5866	.5622	●	3	●	4	●	4	●	4		
STI 5/8	11	0.7431	4.921	1.181	—	0.590	0.442	0.6496	.5623	●	3	●	5	●	5	●	5		
STI 3/4	10	0.8799	5.512	1.260	—	0.697	0.523	0.7776	.5624	●	3	●	5	●	5	●	5		
STI 7/8	9	1.0193	6.299	1.417	—	0.800	0.600	0.9055	.5625	●	3	●	5	●	5	●	5		
STI 1	8	1.1624	7.087	1.575	—	1.021	0.766	1.0335	.5626	●	3	●	5	●	5	●	5		

DIN Length • ANSI Shank

Overall length acc. to DIN 371, DIN 374

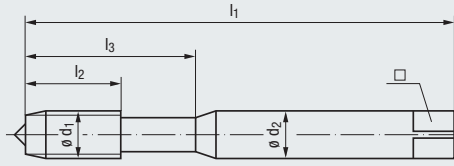

Reinforced Shank
(STI-No.4 - STI 5/16)

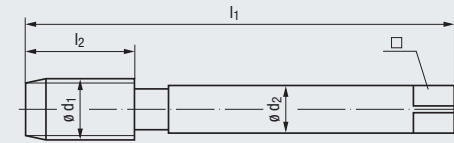

Reduced Shank
(STI 3/8 - STI 1)

STI-UNF

Unified Fine Thread
ASME B18.29.1

For wire thread inserts



Class of Fit
Coating
Cutting Material
Technical Characteristics



Thread Depth
and Hole Shape

Applications – Material



3B	3B	3B	3B
NT	GLT-1	GLT-8	GLT-8
HSS Extra	HSS Extra	HSS Extra	HSS Extra
B / 4-5	B / 4-5	B / approx. 3	E / 1.5-2
E / O / P	E / O / P	E / O	E / O
max. 3 x d ₁		max. 3 x d ₁	max. 2.5 x d ₁

P 1.1-3.1	P 1.1-4.1	N 1.1-4	N 1.1-4
M 1.1-2.1	M 1.1-3.1		
K 2.1	K 2.1		
N 2.2, 2.5-6	N 2.2		

Reinforced Shank

Nominal Size ø d ₁	T.P.I.	inch						Tool Identification		BU203010		BU20C310		BU20S810		BU51S810	
		ø d ₁	l ₁	l ₂	l ₃	ø d ₂	□	Dimens. ID	Rekord 1B-VA NT	Flutes	Rekord 1B-VA GLT-1	Flutes	Rekord 1B-AL GLT-8	Flutes	Enorm 1-AL/E GLT-8	Flutes	
STI-No. 4	48	0.1391	2.205	0.472	0.787	0.141	0.110	0.1181	.5633	●	3	●	3				
STI-No. 6	40	0.1705	2.480	0.512	0.827	0.168	0.131	0.1457	.5635	●	3	●	3				
STI-No. 8	36	0.2001	3.150	0.512	1.142	0.220	0.165	0.1732	.5636	●	3	●	3	●	2	●	2
STI-No. 10	32	0.2306	3.150	0.512	1.181	0.255	0.191	0.2008	.5637	●	3	●	3	●	2	●	2
STI 1/4	28	0.2964	3.543	0.669	1.260	0.318	0.238	0.2598	.5639	●	3	●	3	●	2	●	2
STI 5/16	24	0.3666	3.937	0.709	1.535	0.381	0.286	0.3248	.5640	●	4	●	4	●	3	●	2

Reduced Shank

Nominal Size ø d ₁	T.P.I.	inch						Tool Identification		CU203010		CU20C310		CU20S810		CU51S810	
		ø d ₁	l ₁	l ₂	l ₃	ø d ₂	□	Dimens. ID	Rekord 2B-VA NT	Flutes	Rekord 2B-VA GLT-1	Flutes	Rekord 2B-AL GLT-8	Flutes	Enorm 2-AL/E GLT-8	Flutes	
STI 3/8	24	0.4291	3.937	0.709	—	0.323	0.242	0.3858	.5641	●	4	●	4	●	4	●	3
STI 7/16	20	0.5025	3.937	0.866	—	0.367	0.275	0.4528	.5642	●	3	●	3			●	4
STI 1/2	20	0.5650	3.937	0.866	—	0.429	0.322	0.5157	.5643	●	3	●	3	●	3	●	4
STI 9/16	18	0.6347	3.937	0.866	—	0.480	0.360	0.5787	.5644	●	3	●	3				
STI 5/8	18	0.6972	4.331	0.984	—	0.542	0.406	0.6398	.5645	●	4	●	4				
STI 3/4	16	0.8312	4.921	0.984	—	0.652	0.489	0.7677	.5646	●	4	●	4				
STI 7/8	14	0.9677	5.512	1.102	—	0.800	0.600	0.8957	.5647			●	4				
STI 1	12	1.1083	5.986	1.181	—	0.896	0.672	1.0236	.5648			●	4				

● = In stock
★ = Allow 7 days for delivery

Product Finder

- V_c
- UNC
- UNF
- UNEF
- UN-8
- MF
- NPSM/NPSC
- NPSF
- R_p (BSPP)
- G
- NPT
- NPTF
- R_c (BSPT)
- STI
- SELF-LOCK
- Accessories
- Tech. Info



- Product Finder
- V_c
- UNC
- UNF
- UNEF
- UN-8
- M
- MF
- NPSM/NPSC
- NPSF
- Rp (BSPP)
- G
- NPT
- NPTF
- Rc (BSPT)
- STI
- SELF-LOCK
- Accessories
- Tech. Info

DIN Length - ANSI Shank

Overall length acc. to DIN 371, DIN 374

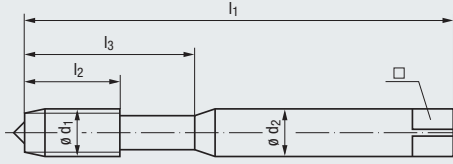

Reinforced Shank
(STI-No.4 - STI 5/16)

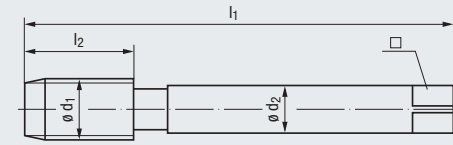

Reduced Shank
(STI 3/8 - STI 1)

TI
Titanium



NI
Nickel
Alloys

new



STI-UNF

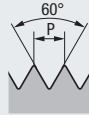

Unified Fine Thread
ASME B18.29.1

For wire thread inserts

Class of Fit: **3BX**
Coating: **NT2**
Cutting Material: **HSS Extra**
Technical Characteristics: **R15**
C / 2-3
E / O / P

Thread Depth and Hole Shape: max. 2 x d₁



Class of Fit: **3BX**
Coating: **TICN**
Cutting Material: **HSSE-PM**
Technical Characteristics: **R10**
C / 2-3
O / P

Thread Depth and Hole Shape: max. 2 x d₁



Applications - Material

- P 4.1-5.1**
- M 3.1-4.1**
- N 2.4-5, 2.7**
- S 1.1-2.2, 2.4**

- M 4.1**
- N 2.8**
- S 1.2-3**
- S 2.3, 2.5-6**

Reinforced Shank

Nominal Size ø d ₁	T.P.I.	inch						□	Tool Identification		BU456011		BU35J411	
		ø d ₁	l ₁	l ₂	l ₃	ø d ₂	□		Dimens. ID	Rekord 1D-TI NT2	Flutes	Rekord 1DF-NI-PM TICN	Flutes	
STI-No. 4	48	0.1391	2.205	0.472	0.787	0.141	0.110	0.1181	.5633	●	3			
STI-No. 6	40	0.1705	2.480	0.512	0.827	0.168	0.131	0.1457	.5635	●	3			
STI-No. 8	36	0.2001	3.150	0.512	1.142	0.220	0.165	0.1732	.5636	●	3			
STI-No. 10	32	0.2306	3.150	0.512	1.181	0.255	0.191	0.2008	.5637	●	3	●	3	
STI 1/4	28	0.2964	3.543	0.669	1.260	0.318	0.238	0.2598	.5639	●	3	●	3	
STI 5/16	24	0.3666	3.937	0.709	1.535	0.381	0.286	0.3248	.5640	●	3	●	3	

Reduced Shank

Nominal Size ø d ₁	T.P.I.	inch						□	Tool Identification		CU456011		CU35J411	
		ø d ₁	l ₁	l ₂	l ₃	ø d ₂	□		Dimens. ID	Rekord 2D-TI NT2	Flutes	Rekord 2DF-NI-PM TICN	Flutes	
STI 3/8	24	0.4291	3.937	0.709	—	0.323	0.242	0.3858	.5641	●	3	●	3	
STI 7/16	20	0.5025	3.937	0.866	—	0.367	0.275	0.4528	.5642	●	3	●	3	
STI 1/2	20	0.5650	3.937	0.866	—	0.429	0.322	0.5157	.5643	●	3			
STI 9/16	18	0.6347	3.937	0.866	—	0.480	0.360	0.5787	.5644	●	3			
STI 5/8	18	0.6972	4.331	0.984	—	0.542	0.406	0.6398	.5645	●	4			
STI 3/4	16	0.8312	4.921	0.984	—	0.652	0.489	0.7677	.5646	●	4			
STI 7/8	14	0.9677	5.512	1.102	—	0.800	0.600	0.8957	.5647					
STI 1	12	1.1083	5.986	1.181	—	0.896	0.672	1.0236	.5648					

DIN Length - ANSI Shank

Overall length acc. to DIN 371, DIN 374

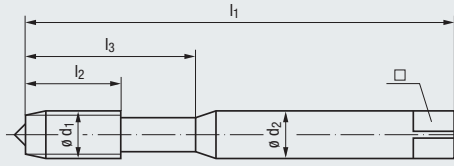

Reinforced Shank
(STI-No.4 - STI 5/16)

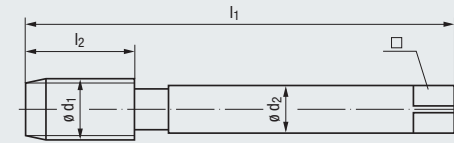

Reduced Shank
(STI 3/8 - STI 1)

STI-UNF

Unified Fine Thread
ASME B18.29.1

For wire thread inserts

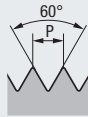

Class of Fit
Coating
Cutting Material
Technical Characteristics



Thread Depth
and Hole Shape

Applications - Material

max. 3 x d₁



Z CNC-Controlled Machines																		
3B	3B	3B																
TIN	GLT-1																	
HSS Extra	HSS Extra	HSS Extra																
R45	R45	R45																
E / 1.5-2	E / 1.5-2	E / 1.5-2																
E / O / P	E / O / P	E / O / P																
<table border="1"> <thead> <tr> <th>P</th> <th>M</th> <th>N</th> <th>S</th> </tr> </thead> <tbody> <tr> <td>1.1-4.1</td> <td>1.1-3.1</td> <td>1.4-6</td> <td>1.1</td> </tr> <tr> <td>1.1-2.1</td> <td>1.4-6</td> <td>2.1-2, 2.4-5</td> <td></td> </tr> <tr> <td>2.1</td> <td></td> <td></td> <td></td> </tr> </tbody> </table>			P	M	N	S	1.1-4.1	1.1-3.1	1.4-6	1.1	1.1-2.1	1.4-6	2.1-2, 2.4-5		2.1			
P	M	N	S															
1.1-4.1	1.1-3.1	1.4-6	1.1															
1.1-2.1	1.4-6	2.1-2, 2.4-5																
2.1																		

Reinforced Shank

Nominal Size ø d ₁	T.P.I.	inch						□	Tool Identification		BU513510		BU513710		BU51C410	
		ø d ₁	l ₁	l ₂	l ₃	ø d ₂	Dimens. ID		Enorm 1-Z/E	Flutes	Enorm 1-Z/E TIN	Flutes	Enorm 1-Z/E GLT-1	Flutes		
STI-No. 4	48	0.1391	2.205	0.276	0.787	0.141	0.110	0.1181	.5633	●	3			●	3	
STI-No. 6	40	0.1705	2.480	0.276	0.827	0.168	0.131	0.1457	.5635	●	3			●	3	
STI-No. 8	36	0.2001	3.150	0.315	1.142	0.220	0.165	0.1732	.5636	●	3			●	3	
STI-No. 10	32	0.2306	3.150	0.394	1.181	0.255	0.191	0.2008	.5637	●	3	●	3	●	3	
STI 1/4	28	0.2964	3.543	0.394	1.260	0.318	0.238	0.2598	.5639	●	3	●	3	●	3	
STI 5/16	24	0.3666	3.937	0.394	1.535	0.381	0.286	0.3248	.5640	●	3	●	3	●	3	

Reduced Shank

Nominal Size ø d ₁	T.P.I.	inch						□	Tool Identification		CU513510		CU513710		CU51C410	
		ø d ₁	l ₁	l ₂	l ₃	ø d ₂	Dimens. ID		Enorm 2-Z/E	Flutes	Enorm 2-Z/E TIN	Flutes	Enorm 2-Z/E GLT-1	Flutes		
STI 3/8	24	0.4291	3.937	0.394	—	0.323	0.242	0.3858	.5641	●	4	●	4	●	4	
STI 7/16	20	0.5025	3.937	0.512	—	0.367	0.275	0.4528	.5642	●	5	●	5	●	5	
STI 1/2	20	0.5650	3.937	0.591	—	0.429	0.322	0.5157	.5643	●	5	●	5	●	5	
STI 9/16	18	0.6347	3.937	0.591	—	0.480	0.360	0.5787	.5644	●	5	●	5	●	5	
STI 5/8	18	0.6972	4.331	0.669	—	0.542	0.406	0.6398	.5645	●	5	●	5	●	5	
STI 3/4	16	0.8312	4.921	0.669	—	0.652	0.489	0.7677	.5646	●	5	●	5	●	5	
STI 7/8	14	0.9677	5.512	0.787	—	0.800	0.600	0.8957	.5647					●	5	
STI 1	12	1.1083	5.986	0.866	—	0.896	0.672	1.0236	.5648					●	5	

● = In stock
★ = Allow 7 days for delivery

- Product Finder
- V_c
- UNC
- UNF
- UNEF
- UN-8
- MF
- NPSM/NPSC
- NPSF
- R_p (BSPP)
- G
- NPT
- NPTF
- R_c (BSPT)
- STI
- SELF-LOCK
- Accessories
- Tech. Info



- Product Finder
- V_c
- UNC
- UNF
- UNEF
- UN-8
- M
- MF
- NPSM/NPSC
- NPSF
- Rp (BSPP)
- G
- NPT
- NPTF
- Rc (BSPT)
- STI
- SELF-LOCK
- Accessories
- Tech. Info

DIN Length · DIN Shank

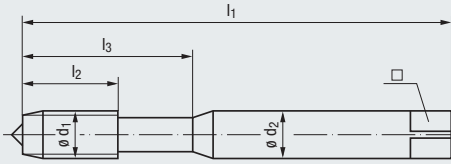

Reinforced Shank
(STI-M2.5 - STI-M8)

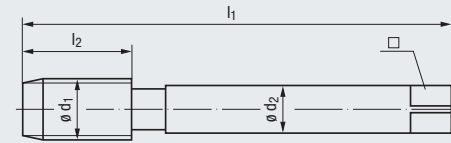

Reduced Shank
(STI-M10 - STI-M20)

STI-M

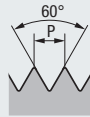

ISO Metric Coarse Thread
DIN 8140-2

For wire thread inserts

Class of Fit: 6H mod.
Coating: NT
Cutting Material: HSS Extra
Technical Characteristics: B / 4-5, E / O / P

Thread Depth and Hole Shape

Applications – Material

VA
Stainless Steel
Materials



AL
Aluminum
Wrought Alloys



6H mod.	6H mod.	6H mod.	6H mod.
NT	GLT-1	GLT-8	GLT-8
HSS Extra	HSS Extra	HSS Extra	HSS Extra
B / 4-5	B / 4-5	B / approx. 3	C / 2-3
E / O / P	E / O / P	E / O	E / O

max. 3 x d ₁	max. 3 x d ₁	max. 2.5 x d ₁
-------------------------	-------------------------	---------------------------

P 1.1-3.1	P 1.1-4.1	N 1.1-4	N 1.1-4
M 1.1-2.1	M 1.1-3.1		
K 2.1	K 2.1		
N 2.2, 2.5-6	N 2.2		

Reinforced Shank

Nominal Size ø d ₁	P	ø d ₁	l ₁	mm		ø d ₂	□	Tool Identification		B0203000		B020C300		B020S800		B050S800	
				l ₂	l ₃			Rekord 1B-VA NT	Flutes	Rekord 1B-VA GLT-1	Flutes	Rekord 1B-AL GLT-8	Flutes	Enorm 1-AL GLT-8	Flutes		
STI-M 2.5	0.45	3.085	56	11	18	3.5	2.7	2.65	.0965	●	3	●	3	●	2	●	2
STI-M 3	0.5	3.650	63	10	21	4.5	3.4	3.15	.0966	●	3	●	3	●	2	●	2
STI-M 4	0.7	4.910	70	12	25	6	4.9	4.2	.0968	●	3	●	3	●	2	●	2
STI-M 5	0.8	6.040	80	13	30	6	4.9	5.25	.0970	●	3	●	3	●	2	●	2
STI-M 6	1	7.300	90	17	35	8	6.2	6.3	.0971	●	3	●	3	●	2	●	2
STI-M 8	1.25	9.624	100	18	39	10	8	8.4	.0973	●	3	●	3	●	3	●	2

Reduced Shank

Nominal Size ø d ₁	P	ø d ₁	l ₁	mm		ø d ₂	□	Tool Identification		C0203000		C020C300		C020S800	
				l ₂	l ₃			Rekord 2B-VA NT	Flutes	Rekord 2B-VA GLT-1	Flutes	Rekord 2B-AL GLT-8	Flutes		
STI-M 10	1.5	11.948	100	22	—	9	7	10.5	.0975	●	3	●	3	●	3
STI-M 12	1.75	14.274	110	26	—	11	9	12.5	.0977	●	3	●	3	●	3
STI-M 14	2	16.598	110	27	—	12	9	14.5	.0978						
STI-M 16	2	18.598	125	27	—	14	11	16.5	.0979	●	3	●	3		
STI-M 18	2.5	21.248	140	32	—	18	14.5	18.75	.0980						
STI-M 20	2.5	23.248	160	34	—	18	14.5	20.75	.0981	●	3	●	3		

DIN Length • DIN Shank

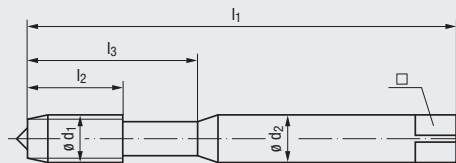

Reinforced Shank
(STI-M2.5 - STI-M8)

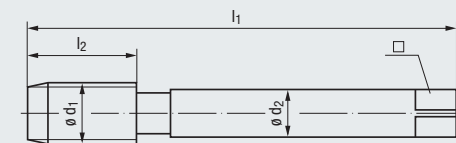

Reduced Shank
(STI-M10 - STI-M20)

STI-M

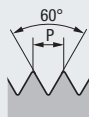

ISO Metric Coarse Thread
DIN 8140-2

For wire thread inserts

Class of Fit: 6H mod.
Coating: HSS Extra
Cutting Material: R45
Technical Characteristics: C / 2-3, E / O / P



Thread Depth and Hole Shape

Applications – Material

6H mod.	6H mod.	6H mod.
HSS Extra	HSS Extra	HSS Extra
R45	R45	R45
C / 2-3	E / 1.5-2	E / 1.5-2
E / O / P	E / O / P	E / O / P

max. 3 x d₁



P 1.1-4.1	P 1.1-4.1	P 1.1-4.1
M 1.1-2.1	M 1.1-2.1	M 1.1-3.1
N 2.1	N 2.1	N 1.4-6
		N 2.1-2, 2.4-5
		S 1.1

Reinforced Shank

Nominal Size ø d ₁	P	ø d ₁	l ₁	mm			□	Tool Identification		B0503500		B0513500		B051C400	
				l ₂	l ₃	ø d ₂		Dimens. ID	Enorm 1-Z	Flutes	Enorm 1-Z/E	Flutes	Enorm 1-Z/E GLT-1	Flutes	
STI-M 2.5	0.45	3.085	56	5	18	3.5	2.7	2.65	.0965	●	3	●	3	●	3
STI-M 3	0.5	3.650	63	5	21	4.5	3.4	3.15	.0966	●	3	●	3	●	3
STI-M 4	0.7	4.910	70	8	25	6	4.9	4.2	.0968	●	3	●	3	●	3
STI-M 5	0.8	6.040	80	8	30	6	4.9	5.25	.0970	●	3	●	3	●	3
STI-M 6	1	7.300	90	10	35	8	6.2	6.3	.0971	●	3	●	3	●	3
STI-M 8	1.25	9.624	100	16	39	10	8	8.4	.0973	●	3	●	3	●	3

Reduced Shank

Nominal Size ø d ₁	P	ø d ₁	l ₁	mm			□	Tool Identification		C0503500		C0513500		C051C400	
				l ₂	l ₃	ø d ₂		Dimens. ID	Enorm 2-Z	Flutes	Enorm 2-Z/E	Flutes	Enorm 2-Z/E GLT-1	Flutes	
STI-M 10	1.5	11.948	100	15	—	9	7	10.5	.0975	●	5	●	5	●	5
STI-M 12	1.75	14.274	110	20	—	11	9	12.5	.0977	●	4	●	4	●	4
STI-M 14	2	16.598	110	20	—	12	9	14.5	.0978						
STI-M 16	2	18.598	125	20	—	14	11	16.5	.0979	●	5	●	5	●	5
STI-M 18	2.5	21.248	140	27	—	18	14.5	18.75	.0980						
STI-M 20	2.5	23.248	160	30	—	18	14.5	20.75	.0981	●	5	●	5	●	5

- Product Finder
- V_c
- UNC
- UNF
- UNEF
- UN-8
- ...
- MF
- NPSM/NPSC
- NPSF
- R_p (BSPP)
- G
- NPT
- NPTF
- R_c (BSPT)
- STI
- SELF-LOCK
- Accessories
- Tech. Info



● = In stock
★ = Allow 7 days for delivery

- Product Finder
- V_c
- UNC
- UNF
- UNEF
- UN-8
- M
- MF
- NPSM/NPSC
- NPSF
- Rp (BSPP)
- G
- NPT
- NPTF
- Rc (BSPT)
- STI
- SELF-LOCK
- Accessories
- Tech. Info

DIN Length - ANSI Shank

Overall length acc. to DIN 371, DIN 376

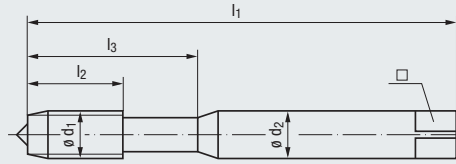

Reinforced Shank
(LK No.4 - LK 3/8)

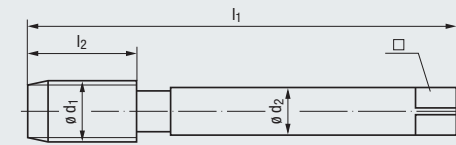

Reduced Shank
(LK 7/16 - LK 1)

LK-UNC

Unified SELF-LOCK Coarse Thread
EMUGE Standard

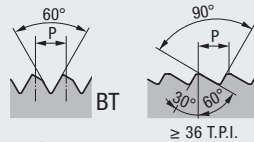

Type: BT
Coating: HSS Extra
Cutting Material: B / 4-5, E / 0
Technical Characteristics:

Thread Depth and Hole Shape: max. 3 x d₁

Applications - Material: P 1.1-3.1, N 2.2

STEEL
Steel
Materials



TI
Titanium



Reinforced Shank

Nominal Size ø d ₁	T.P.I.	l ₁	l ₂	inch l ₃	ø d ₂	□	Tool Identification		BU208900		BU309600		BU459600	
								Dimens. ID	Rekord 1B-STEEL-L	Flutes	Rekord 1C-TI TICN	Flutes	Rekord 1D-TI TICN	Flutes
LK No. 4	40	2.205	0.443	0.709	0.141	0.110	0.0965	.5656			●	2	●	2
LK No. 6	32	2.205	0.472	0.787	0.141	0.110	0.1142	.5658			●	3	●	3
LK No. 8	32	2.480	0.512	0.827	0.168	0.131	0.1417	.5659			●	3	●	3
LK No. 10	24	2.756	0.591	0.984	0.194	0.152	0.1575	.5660			●	3	●	3
LK No. 12	24	3.150	0.630	1.142	0.220	0.165	0.1850	.5661			●	3	●	3
LK 1/4	20	3.150	0.669	1.181	0.255	0.191	0.2087	.5662	●	3	●	3	●	3
LK 5/16	18	3.543	0.787	1.378	0.318	0.238	0.2677	.5663	●	3	●	3	●	3
LK 3/8	16	3.937	0.866	1.535	0.381	0.286	0.3268	.5664	●	3	●	3	●	3

Reduced Shank

Nominal Size ø d ₁	T.P.I.	l ₁	l ₂	inch l ₃	ø d ₂	□	Tool Identification		CU208900		CU309600		CU459600	
								Dimens. ID	Rekord 2B-STEEL-L	Flutes	Rekord 2C-TI TICN	Flutes	Rekord 2D-TI TICN	Flutes
LK 7/16	14	3.937	0.866	—	0.323	0.242	0.3819	.5665			●	3	●	3
LK 1/2	13	4.331	0.984	—	0.367	0.275	0.4409	.5666	●	3	●	3	●	3
LK 9/16	12	4.331	1.024	—	0.429	0.322	0.4961	.5667						
LK 5/8	11	4.331	1.063	—	0.480	0.360	0.5512	.5668						
LK 3/4	10	4.921	1.181	—	0.590	0.442	0.6693	.5669						
LK 7/8	9	5.512	1.260	—	0.697	0.523	0.7874	.5670						
LK 1	8	6.299	1.417	—	0.800	0.600	0.8976	.5671						

DIN Length • ANSI Shank

Overall length acc. to DIN 371, DIN 376

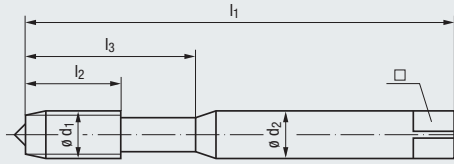

Reinforced Shank
(LK No.4 - LK 3/8)

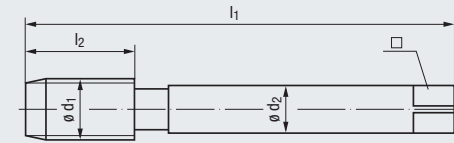

Reduced Shank
(LK 7/16 - LK 1)

LK-UNC

Unified SELF-LOCK Coarse Thread
EMUGE Standard

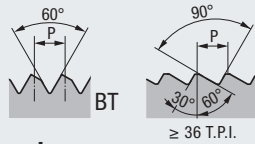

Type
Coating
Cutting Material
Technical Characteristics



BT	BT	BT
GLT-1	GLT-1	GLT-1
HSSE-PM	HSS Extra	HSS Extra
R45	R45	R45
B / 4-5	E / 1.5-2	E / 1.5-2
E / O / P	E / O / P	E / O / P

Thread Depth and Hole Shape

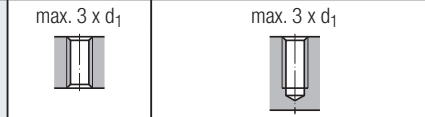

Applications – Material

P 1.1-5.1	P 1.1-4.1	P 1.1-4.1
M 1.1-3.1	M 1.1-2.1	M 1.1-3.1
K 2.1	N 2.1	N 1.4-6
N 1.4-2.2, 2.4-5		N 2.1-2, 2.4-5
S 1.1		S 1.1

Reinforced Shank

Nominal Size ø d ₁	T.P.I.	l ₁	l ₂	inch l ₃	ø d ₂	□	Tool Identification		BU20A600		BU513500		BU51C400	
							Image	Dimens. ID	Rekord 1B-Z-PM GLT-1	Flutes	Enorm 1-Z/E	Flutes	Enorm 1-Z/E GLT-1	Flutes
LK No. 4	40	2.205	0.236	0.709	0.141	0.110	0.0965	.5656	●	2			●	2
LK No. 6	32	2.205	0.276	0.787	0.141	0.110	0.1142	.5658	●	3			●	3
LK No. 8	32	2.480	0.315	0.827	0.168	0.131	0.1417	.5659	●	3			●	3
LK No. 10	24	2.756	0.394	0.984	0.194	0.152	0.1575	.5660	●	3			●	3
LK No. 12	24	3.150	0.394	1.142	0.220	0.165	0.1850	.5661	●	3			●	3
LK 1/4	20	3.150	0.512	1.181	0.255	0.191	0.2087	.5662	●	3	●	3	●	3
LK 5/16	18	3.543	0.551	1.378	0.318	0.238	0.2677	.5663	●	4	●	3	●	3
LK 3/8	16	3.937	0.630	1.535	0.381	0.286	0.3268	.5664	●	4	●	3	●	3

Reduced Shank

Nominal Size ø d ₁	T.P.I.	l ₁	l ₂	inch l ₃	ø d ₂	□	Tool Identification		CU20A600		CU513500		CU51C400	
							Image	Dimens. ID	Rekord 2B-Z-PM GLT-1	Flutes	Enorm 2-Z/E	Flutes	Enorm 2-Z/E GLT-1	Flutes
LK 7/16	14	3.937	0.709	—	0.323	0.242	0.3819	.5665	●	4			●	4
LK 1/2	13	4.331	0.787	—	0.367	0.275	0.4409	.5666	●	4	●	4	●	4
LK 9/16	12	4.331	0.787	—	0.429	0.322	0.4961	.5667	●	4			●	4
LK 5/8	11	4.331	0.866	—	0.480	0.360	0.5512	.5668	●	4			●	4
LK 3/4	10	4.921	0.984	—	0.590	0.442	0.6693	.5669	●	4			●	4
LK 7/8	9	5.512	1.063	—	0.697	0.523	0.7874	.5670	●	4			●	5
LK 1	8	6.299	1.181	—	0.800	0.600	0.8976	.5671	●	4			●	5

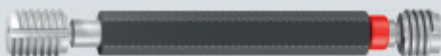

Gages for Unified SELF-LOCK coarse thread, see page 455

● = In stock
★ = Allow 7 days for delivery

Product Finder

V_c

UNC

UNF

UNEF

UN-8

MF

NPSM/NPSC

NPSF

R_p (BSPP)

G

NPT

NPTF

R_c (BSPT)

STI

SELF-LOCK

Accessories

Tech. Info



- Product Finder
- V_c
- UNC
- UNF
- UNEF
- UN-8
- M
- MF
- NPSM/NPSC
- NPSF
- Rp (BSPP)
- G
- NPT
- NPTF
- Rc (BSPT)
- STI
- SELF-LOCK
- Accessories
- Tech. Info

DIN Length - ANSI Shank

Overall length acc. to DIN 371, DIN 374

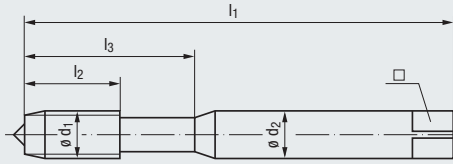

Reinforced Shank
(LK No.4 - LK 3/8)

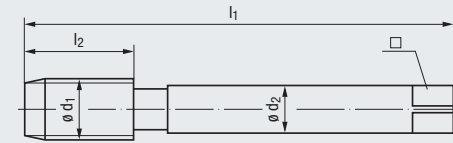

Reduced Shank
(LK 7/16 - LK 3/4)

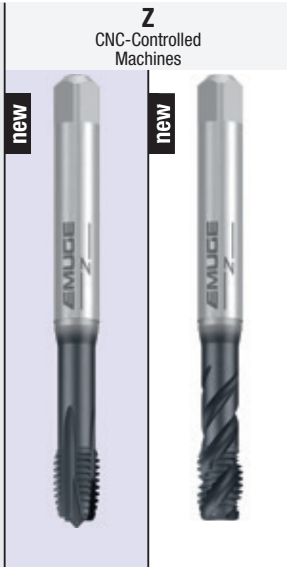

Z
CNC-Controlled
Machines

LK-UNF

Unified SELF-LOCK Fine Thread
EMUGE Standard

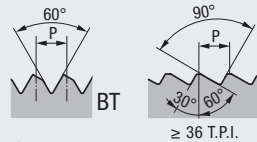

Type
Coating
Cutting Material
Technical Characteristics

Type	BT	BT
Coating	GLT-1	GLT-1
Cutting Material	HSSE-PM	HSS Extra
Technical Characteristics	B / 4-5	R45
	E / O / P	E / 1.5-2
		E / O / P

Thread Depth
and Hole Shape

Thread Depth and Hole Shape	max. 3 x d ₁	max. 3 x d ₁

Applications - Material

Applications - Material	P 1.1-5.1 M 1.1-3.1 K 2.1 N 1.4-2.2, 2.4-5 S 1.1	P 1.1-4.1 M 1.1-3.1 N 1.4-6 N 2.1-2, 2.4-5 S 1.1
-------------------------	--	--

Reinforced Shank

Nominal Size $\varnothing d_1$	T.P.I.	l ₁	l ₂	inch		$\varnothing d_2$	□	Tool Identification		CU20A600		CU51C400	
				l ₃				Rekord 1B-Z-PM GLT-1	Flutes	Enorm 1-Z/E GLT-1	Flutes		
LK No. 4	48	2.205	0.236	0.709	0.141	0.110	0.0996	.5707	●	2	●	2	
LK No. 6	40	2.205	0.276	0.787	0.141	0.110	0.1220	.5709	●	3	●	3	
LK No. 8	36	2.480	0.315	0.827	0.168	0.131	0.1476	.5710	●	3	●	3	
LK No. 10	32	2.756	0.394	0.984	0.194	0.152	0.1654	.5711	●	3	●	3	
LK 1/4	28	3.150	0.394	1.181	0.255	0.191	0.2244	.5713	●	3	●	3	
LK 5/16	24	3.543	0.394	1.260	0.318	0.238	0.2835	.5714	●	4	●	3	
LK 3/8	24	3.937	0.394	1.535	0.381	0.286	0.3425	.5715	●	4	●	3	

Reduced Shank

Nominal Size $\varnothing d_1$	T.P.I.	l ₁	l ₂	inch		$\varnothing d_2$	□	Tool Identification		CU20A600		CU51C400	
				l ₃				Rekord 2B-Z-PM GLT-1	Flutes	Enorm 2-Z/E GLT-1	Flutes		
LK 7/16	20	3.937	0.512	—	0.323	0.242	0.4016	.5716	●	4	●	4	
LK 1/2	20	3.937	0.512	—	0.367	0.275	0.4606	.5717	●	4	●	5	
LK 9/16	18	3.937	0.591	—	0.429	0.322	0.5197	.5718	●	4	●	5	
LK 5/8	18	3.937	0.591	—	0.480	0.360	0.5827	.5719	●	4	●	5	
LK 3/4	16	4.331	0.669	—	0.590	0.442	0.7008	.5720	●	4	●	5	

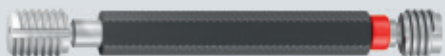

Gages for Unified SELF-LOCK fine thread, see page 456

DIN Length • DIN Shank

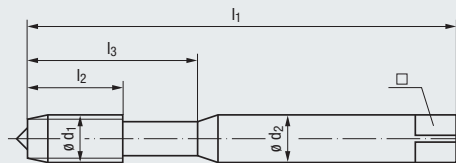

Reinforced Shank
(LK-M3 - LK-M10)

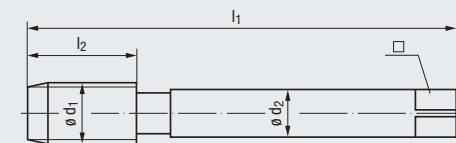

Reduced Shank
(LK-M12 - LK-M24)

LK-M

Metric SELF-LOCK Coarse Thread
EMUGE Standard

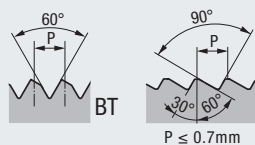

Type
Coating
Cutting Material
Technical Characteristics

Thread Depth
and Hole Shape

Applications – Material



BT	BT	BT
NT	TIN	NT
HSS Extra	HSS Extra	HSS Extra
B / 4-5	B / 4-5	C / 2-3
E / O / P	E / O / P	E

max. 3 x d_1	max. 2 x d_1

P 1.1-3.1	P 1.1-4.1	K 1.1-2
M 1.1-2.1	M 1.1-3.1	
K 2.1	K 2.1	
N 2.2, 2.5-6	N 2.2, 2.5-6	

Reinforced Shank

Nominal Size $\varnothing d_1$	P	l_1	l_2	mm			$\varnothing d_2$	\square	Tool Identification		B0203000		B0203100		B0102000	
				l_3	$\varnothing d_2$	\square			Rekord 1B-VA NT	Flutes	Rekord 1B-VA TIN	Flutes	Rekord 1A-GG NT	Flutes		
LK-M 3	0.5	56	11	18	3.5	2.7	2.7	.1046								
LK-M 4	0.7	63	13	21	4.5	3.4	3.55	.1048								
LK-M 5	0.8	70	15	25	6	4.9	4.4	.1050								
LK-M 6	1	80	17	30	6	4.9	5.2	.1052	●	3	●	3	●	3	●	3
LK-M 8	1.25	90	20	35	8	6.2	7	.1054	●	3	●	3	●	3	●	3
LK-M 10	1.5	100	22	39	10	8	8.8	.1056	●	3	●	3	●	3	●	3

Reduced Shank

Nominal Size $\varnothing d_1$	P	l_1	l_2	mm			$\varnothing d_2$	\square	Tool Identification		C0203000		C0203100		C0102000	
				l_3	$\varnothing d_2$	\square			Rekord 2B-VA NT	Flutes	Rekord 2B-VA TIN	Flutes	Rekord 2A-GG NT	Flutes		
LK-M 12	1.75	110	24	—	9	7	10.7	.1058	●	3	●	3	●	3	●	3
LK-M 14	2	110	26	—	11	9	12.5	.1059								
LK-M 16	2	110	27	—	12	9	14.5	.1060	●	3	●	3	●	3	●	3
LK-M 20	2.5	140	32	—	16	12	18	.1062								
LK-M 24	3	160	34	—	18	14.5	21.5	.1064								

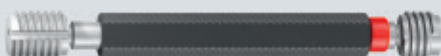

Gages for Metric SELF-LOCK coarse thread, see page 457

● = In stock
★ = Allow 7 days for delivery

- Product Finder
- Vc
- UNC
- UNF
- UNEF
- UN-8
- M
- MF
- NPSM/NPSC
- NPSF
- Rp (BSPP)
- G
- NPT
- NPTF
- Rc (BSPT)
- STI
- SELF-LOCK**
- Accessories
- Tech. Info

DIN Length • DIN Shank

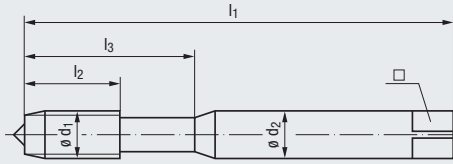

Reinforced Shank
(LK-M3 - LK-M10)

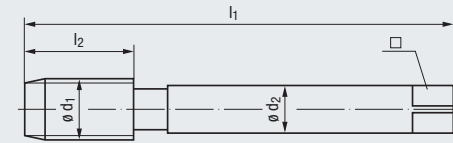

Reduced Shank
(LK-M12 - LK-M24)

Z
CNC-Controlled
Machines



LK-M

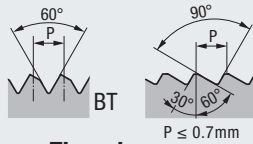

Metric SELF-LOCK Coarse Thread
EMUGE Standard

Type
Coating
Cutting Material
Technical Characteristics

- BT
- HSS Extra
- R45
- E / 1.5-2**
- E / O / P

Thread Depth
and Hole Shape

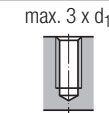

Applications – Material

- P 1.1-4.1**
- M 1.1-2.1**
- N 2.1**

Reinforced Shank

Nominal Size Ø d ₁	P	l ₁	mm			Ø d ₂	□	Tool Identification		B0513500	
			l ₂	l ₃	Ø d ₂			□	Dimens. ID	Enorm 1-Z/E	Flutes
LK-M 3	0.5	56	6	18	3.5	2.7	2.7	.1046	●	3	
LK-M 4	0.7	63	7	21	4.5	3.4	3.55	.1048	●	3	
LK-M 5	0.8	70	8	25	6	4.9	4.4	.1050	●	3	
LK-M 6	1	80	10	30	6	4.9	5.2	.1052	●	3	
LK-M 8	1.25	90	14	35	8	6.2	7	.1054	●	3	
LK-M 10	1.5	100	16	39	10	8	8.8	.1056	●	3	

Reduced Shank

Nominal Size Ø d ₁	P	l ₁	mm			Ø d ₂	□	Tool Identification		C0513500	
			l ₂	l ₃	Ø d ₂			□	Dimens. ID	Enorm 2-Z/E	Flutes
LK-M 12	1.75	110	18	—	9	7	10.7	.1058	●	4	
LK-M 14	2	110	20	—	11	9	12.5	.1059	●	4	
LK-M 16	2	110	22	—	12	9	14.5	.1060	●	4	
LK-M 20	2.5	140	25	—	16	12	18	.1062	●	4	
LK-M 24	3	160	30	—	18	14.5	21.5	.1064	●	4	

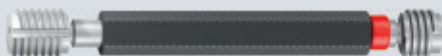

Gages for Metric SELF-LOCK coarse thread, see page 457



Increase Productivity and Tap Life

EMUGE Tapping Fluid is an extreme duty drilling and tapping fluid. It does not contain chlorinated solvents and is considered environmentally safe. EMUGE Tapping Fluid is thick like honey and will stick to the tap throughout the tapping operation. Ideal for tapping and drilling stainless steel, carbon steel, inconel, monel, hastalloy, titanium, aluminum and other alloys and exotics.

- Greatly extends tap and drill life
- Reduces torque
- Improves finish and size
- Mild pleasant odor
- Does not contain chlorinated solvents

Typical Analysis

Appearance: Light amber oil
 Specific Gravity: 1.108
 Viscosity @100° F: > 900 SUS
 Flash Point (PMCC): 415° F
 % Petroleum Distillate: None

			FZ191900
4 oz.	24 units in case	.JM321	●
16 oz.	12 units in case	.JM322	●
1 gallon	6 units in case	.JM323	●
5 gallon	Plastic can with spout	.JM324	●
55 gallon	Drum	.JM325	●

For safety and disposal information please request a Material Safety Data Sheet (MSDS).



- Product Finder
- V_c
- UNC
- UNF
- UNEF
- UN-8
- M
- MF
- NPSM/NPSC
- NPSF
- Rp (BSPP)
- G
- NPT
- NPTF
- Rc (BSPT)
- STI
- SELF-LOCK
- Accessories
- Tech. Info



For use on CNC machines and conventional thread cutting machinery

Short type

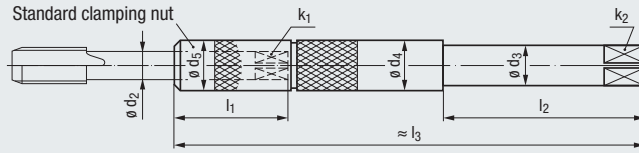

Size	Tap Dimensions				Extension Dimensions						EDP Number	
	ϕd_2	k_1			l_1	ϕd_3 h9	k_2 h12	l_2	$\phi d_4 / d_5$	l_3		
101	0.141	0.110	No. 0 - No. 6	—	0.91	0.255	0.191	2.36	0.295	5.12	FZ111900.101	●
102	0.168	0.131	No. 8	—	0.91	0.255	0.191	2.36	0.331	5.12	FZ111900.102	●
103	0.194	0.152	No. 10	—	0.91	0.255	0.191	2.36	0.398	5.12	FZ111900.103	●
104	0.220	0.165	No. 12	—	1.02	0.255	0.191	2.36	0.476	5.12	FZ111900.104	●
105	0.255	0.191	1/4	—	1.02	0.255	0.191	2.36	0.476	5.12	FZ111900.105	●
106	0.318	0.238	5/16	—	1.18	0.318	0.238	2.36	0.512	5.12	FZ111900.106	●
107	0.323	0.242	—	7/16	1.18	0.323	0.242	3.54	0.512	7.09	FZ111900.107	●
108	0.367	0.275	—	1/2	1.22	0.367	0.275	3.54	0.591	7.09	FZ111900.108	●
109	0.381	0.286	3/8	—	1.30	0.381	0.286	2.36	0.591	5.12	FZ111900.109	●
110	0.429	0.322	—	9/16	1.42	0.429	0.322	3.54	0.709	7.09	FZ111900.110	●
111	0.480	0.360	—	5/8	1.42	0.480	0.360	3.54	0.709	7.09	FZ111900.111	●
112	0.590	0.442	—	3/4	1.57	0.590	0.442	3.54	0.866	7.09	FZ111900.112	●
113	0.697	0.523	—	7/8	1.69	0.697	0.523	3.94	1.024	7.87	FZ111900.113	●
114	0.800	0.600	—	1	1.77	0.800	0.600	3.94	1.102	7.87	FZ111900.114	●
115	0.896	0.672	—	1 1/8	1.85	0.896	0.672	3.94	1.260	7.87	FZ111900.115	●
116	1.021	0.766	—	1 1/4	1.97	1.021	0.766	3.94	1.378	7.87	FZ111900.116	●
117	1.108	0.831	—	1 3/8	2.13	1.108	0.831	3.94	1.496	7.87	FZ111900.117	●
118	1.233	0.925	—	1 1/2	2.44	1.233	0.925	3.94	1.654	7.87	FZ111900.118	●

For use on CNC machines and conventional thread cutting machinery

Short type with coolant-thru (IKZ)

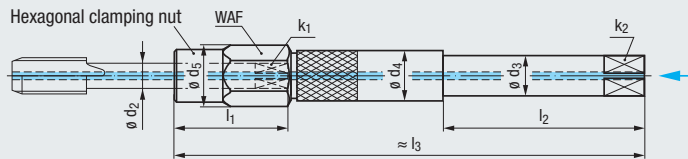

IKZ

p_{max}
700psi
(50bar)

Size	Tap Dimensions				Extension Dimensions						Clamping nut		EDP Number		
	ϕd_2	k_1			l_1	ϕd_3 h9	k_2 h12	l_2	ϕd_4	ϕd_5	l_3	WAF			M _d ¹⁾ ft lbs
101	0.141	0.110	No. 0 - No. 6	—	0.91	0.255	0.191	2.36	0.295	0.354	5.12	0.315	1.5	FZ112320.101	●
102	0.168	0.131	No. 8	—	0.91	0.255	0.191	2.36	0.331	0.394	5.12	0.354	2.1	FZ112320.102	●
103	0.194	0.152	No. 10	—	0.91	0.255	0.191	2.36	0.398	0.531	5.12	0.472	2.4	FZ112320.103	●
104	0.220	0.165	No. 12	—	1.02	0.255	0.191	2.36	0.476	0.531	5.12	0.472	2.6	FZ112320.104	●
105	0.255	0.191	1/4	—	1.02	0.255	0.191	2.36	0.476	0.531	5.12	0.472	3.1	FZ112320.105	●
106	0.318	0.238	5/16	—	1.18	0.318	0.238	2.36	0.512	0.571	5.12	0.512	4.4	FZ112320.106	●
107	0.323	0.242	—	7/16	1.18	0.323	0.242	3.54	0.512	0.571	7.09	0.512	4.9	FZ112320.107	●
108	0.367	0.275	—	1/2	1.22	0.367	0.275	3.54	0.591	0.650	7.09	0.591	5.9	FZ112320.108	●
109	0.381	0.286	3/8	—	1.30	0.381	0.286	2.36	0.591	0.650	5.12	0.591	8.1	FZ112320.109	●
110	0.429	0.322	—	9/16	1.42	0.429	0.322	3.54	0.709	0.787	7.09	0.709	11.1	FZ112320.110	●
111	0.480	0.360	—	5/8	1.42	0.480	0.360	3.54	0.709	0.787	7.09	0.709	14.8	FZ112320.111	●
112	0.590	0.442	—	3/4	1.57	0.590	0.442	3.54	0.866	0.984	7.09	0.866	20.7	FZ112320.112	●
113	0.697	0.523	—	7/8	1.69	0.697	0.523	3.94	1.024	1.142	7.87	1.024	33.2	FZ112320.113	●
114	0.800	0.600	—	1	1.77	0.800	0.600	3.94	1.102	1.260	7.87	1.102	44.3	FZ112320.114	●
115	0.896	0.672	—	1 1/8	1.85	0.896	0.672	3.94	1.260	1.339	7.87	1.181	56.8	FZ112320.115	●
116	1.021	0.766	—	1 1/4	1.97	1.021	0.766	3.94	1.378	1.614	7.87	1.417	88.5	FZ112320.116	●

¹⁾ Recommend tightening torque

Accessories



Spare clamping nuts

» 139



Torque wrenches

» 140

For use on CNC machines and conventional thread cutting machinery

Long type

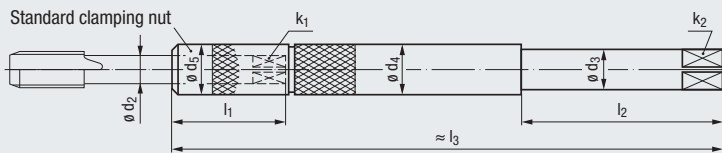

Size	Tap Dimensions				Extension Dimensions						EDP Number	
	ϕd_2	k_1			l_1	ϕd_3 h9	k_2 h12	l_2	$\phi d_4 / d_5$	l_3		
101	0.141	0.110	No. 0 - No. 6	-	0.91	0.255	0.191	2.76	0.295	9.06	FZ111910.101	●
102	0.168	0.131	No. 8	-	0.91	0.255	0.191	2.76	0.331	9.06	FZ111910.102	●
103	0.194	0.152	No. 10	-	0.91	0.255	0.191	2.76	0.398	9.06	FZ111910.103	●
104	0.220	0.165	No. 12	-	1.02	0.255	0.191	2.76	0.476	9.06	FZ111910.104	●
105	0.255	0.191	1/4	-	1.02	0.255	0.191	2.76	0.476	9.06	FZ111910.105	●
106	0.318	0.238	5/16	-	1.18	0.318	0.238	3.15	0.512	9.06	FZ111910.106	●
107	0.323	0.242	-	7/16	1.18	0.323	0.242	3.54	0.512	9.06	FZ111910.107	●
108	0.367	0.275	-	1/2	1.22	0.367	0.275	3.54	0.591	9.06	FZ111910.108	●
109	0.381	0.286	3/8	-	1.30	0.381	0.286	3.54	0.591	9.06	FZ111910.109	●
110	0.429	0.322	-	9/16	1.42	0.429	0.322	3.54	0.709	12.99	FZ111910.110	●
111	0.480	0.360	-	5/8	1.42	0.480	0.360	3.54	0.709	12.99	FZ111910.111	●
112	0.590	0.442	-	3/4	1.57	0.590	0.442	3.54	0.866	12.99	FZ111910.112	●
113	0.697	0.523	-	7/8	1.69	0.697	0.523	3.94	1.024	12.99	FZ111910.113	●
114	0.800	0.600	-	1	1.77	0.800	0.600	3.94	1.102	12.99	FZ111910.114	●
115	0.896	0.672	-	1 1/8	1.85	0.896	0.672	3.94	1.260	12.99	FZ111910.115	●
116	1.021	0.766	-	1 1/4	1.97	1.021	0.766	3.94	1.378	12.99	FZ111910.116	●
117	1.108	0.831	-	1 3/8	2.13	1.108	0.831	3.94	1.496	12.99	FZ111910.117	●
118	1.233	0.925	-	1 1/2	2.44	1.233	0.925	3.94	1.654	12.99	FZ111910.118	●

For use on CNC machines and conventional thread cutting machinery

Long type with coolant-thru (IKZ)

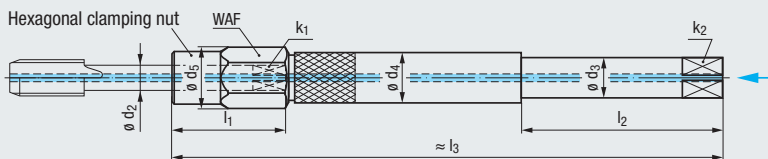

IKZ

p_{max}
700psi
(50bar)

Size	Tap Dimensions				Extension Dimensions						Clamping nut		EDP Number		
	ϕd_2	k_1			l_1	ϕd_3 h9	k_2 h12	l_2	ϕd_4	ϕd_5	l_3	WAF			M_d 1) ft lbs
101	0.141	0.110	No. 0 - No. 6	-	0.91	0.255	0.191	2.76	0.295	0.354	9.06	0.315	1.5	FZ112330.101	●
102	0.168	0.131	No. 8	-	0.91	0.255	0.191	2.76	0.331	0.394	9.06	0.354	2.1	FZ112330.102	●
103	0.194	0.152	No. 10	-	0.91	0.255	0.191	2.76	0.398	0.531	9.06	0.472	2.4	FZ112330.103	●
104	0.220	0.165	No. 12	-	1.02	0.255	0.191	2.76	0.476	0.531	9.06	0.472	2.6	FZ112330.104	●
105	0.255	0.191	1/4	-	1.02	0.255	0.191	2.76	0.476	0.531	9.06	0.472	3.1	FZ112330.105	●
106	0.318	0.238	5/16	-	1.18	0.318	0.238	3.15	0.512	0.571	9.06	0.512	4.4	FZ112330.106	●
107	0.323	0.242	-	7/16	1.18	0.323	0.242	3.54	0.512	0.571	9.06	0.512	4.9	FZ112330.107	●
108	0.367	0.275	-	1/2	1.22	0.367	0.275	3.54	0.591	0.650	9.06	0.591	5.9	FZ112330.108	●
109	0.381	0.286	3/8	-	1.30	0.381	0.286	3.54	0.591	0.650	9.06	0.591	8.1	FZ112330.109	●
110	0.429	0.322	-	9/16	1.42	0.429	0.322	3.54	0.709	0.787	12.99	0.709	11.1	FZ112330.110	●
111	0.480	0.360	-	5/8	1.42	0.480	0.360	3.54	0.709	0.787	12.99	0.709	14.8	FZ112330.111	●
112	0.590	0.442	-	3/4	1.57	0.590	0.442	3.54	0.866	0.984	12.99	0.866	20.7	FZ112330.112	●
113	0.697	0.523	-	7/8	1.69	0.697	0.523	3.94	1.024	1.142	12.99	1.024	33.2	FZ112330.113	●
114	0.800	0.600	-	1	1.77	0.800	0.600	3.94	1.102	1.260	12.99	1.102	44.3	FZ112330.114	●
115	0.896	0.672	-	1 1/8	1.85	0.896	0.672	3.94	1.260	1.339	12.99	1.181	56.8	FZ112330.115	●
116	1.021	0.766	-	1 1/4	1.97	1.021	0.766	3.94	1.378	1.614	12.99	1.417	88.5	FZ112330.116	●

1) Recommend tightening torque

Accessories



Spare clamping nuts

» 139



Torque wrenches

» 140

● = In stock
★ = Allow 7 days for delivery

Product Finder

V_c

UNC

UNF

UNEF

UN-8

MF

NPSM/NPSC

NPSF

R_p (BSPP)

G

NPT

NPTF

R_c (BSPT)

STI

SELF-LOCK

Accessories

Tech. Info



- Product Finder
- V_c
- UNC
- UNF
- UNEF
- UN-8
- M
- MF
- NPSM/NPSC
- NPSF
- Rp (BSPP)
- G
- NPT
- NPTF
- Rc (BSPT)
- STI
- SELF-LOCK
- Accessories
- Tech. Info



For use on CNC machines and conventional thread cutting machinery

Short type

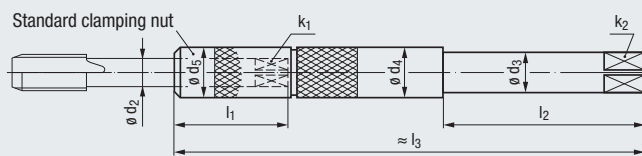

Size	Tap Dimensions				Extension Dimensions						EDP Number	
	$\varnothing d_2$	k_1			l_1	$\varnothing d_3$	k_2	l_2	$\varnothing d_4 / d_5$	l_3		
150	0.3125	0.234	1/16 - 27	—	1.10	0.3125	0.234	2.36	0.512	5.12	FZ111900.150	●
151	0.4375	0.328	1/8 - 27	—	1.10	0.4375	0.328	3.54	0.709	7.09	FZ111900.151	●
152	0.5625	0.421	1/4 - 18	—	1.10	0.5625	0.421	3.54	0.866	7.09	FZ111900.152	●
153	0.6875	0.515	—	1/2 - 14	1.46	0.6875	0.515	3.94	1.024	7.87	FZ111900.153	●
154	0.7000	0.531	3/8 - 18	—	1.20	0.7000	0.531	3.94	1.024	7.87	FZ111900.154	●
155	0.9063	0.679	—	3/4 - 14	1.69	0.9063	0.679	3.94	1.260	7.87	FZ111900.155	●
156	1.1250	0.843	—	1 - 11 1/2	1.81	1.1250	0.843	3.94	1.535	7.87	FZ111900.156	●

Accessories



Spare clamping nuts

» 139



For use on CNC machines and conventional thread cutting machinery

Long type

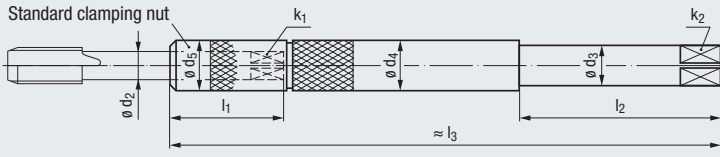

Size	Tap Dimensions				Extension Dimensions					EDP Number		
	$\varnothing d_2$	k_1			l_1	$\varnothing d_3$	k_2	l_2	$\varnothing d_4 / d_5$			l_3
150	0.3125	0.234	1/16 - 27	—	1.10	0.3125	0.234	3.15	0.512	9.06	FZ111910.150	●
151	0.4375	0.328	1/8 - 27	—	1.10	0.4375	0.328	3.54	0.709	12.99	FZ111910.151	●
152	0.5625	0.421	1/4 - 18	—	1.10	0.5625	0.421	3.94	0.866	12.99	FZ111910.152	●
153	0.6875	0.515	—	1/2 - 14	1.46	0.6875	0.515	3.94	1.024	12.99	FZ111910.153	●
154	0.7000	0.531	3/8 - 18	—	1.20	0.7000	0.531	3.94	1.024	12.99	FZ111910.154	●
155	0.9063	0.679	—	3/4 - 14	1.69	0.9063	0.679	3.94	1.260	12.99	FZ111910.155	●
156	1.1250	0.843	—	1 - 11 1/2	1.81	1.1250	0.843	3.94	1.535	12.99	FZ111910.156	●

Accessories



Spare clamping nuts

» 139



Product Finder

Vc

UNC

UNF

UNEF

UN-8

...

MF

NPSM/NPSC

NPSF

Rp (BSPP)

G

NPT

NPTF

Rc (BSPT)

STI

SELF-LOCK

Accessories

Tech. Info



- Product Finder
- V_c
- UNC
- UNF
- UNEF
- UN-8
- M
- MF
- NPSM/NPSC
- NPSF
- Rp (BSPP)
- G
- NPT
- NPTF
- Rc (BSPT)
- STI
- SELF-LOCK
- Accessories
- Tech. Info



For use on CNC machines and conventional thread cutting machinery

Short type

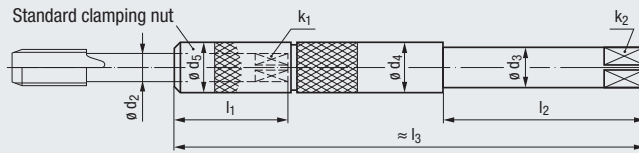

Size	Tap Dimensions				Extension Dimensions						EDP Number	
	$\varnothing d_2$	k_1			l_1	$\varnothing d_3$ h9	k_2 h12	l_2	$\varnothing d_4 / d_5$	l_3		
1	2.8	2.1	M 2 - M2.6	M 4	21	6	4.9	60	6.1	130	FZ111300.01	●
2	3.5	2.7	M 3	M 4.5 - M5	22	6	4.9	60	7.5	130	FZ111300.02	●
3	4	3	M 3.5	M 5.5	22	6	4.9	60	8.4	130	FZ111300.03	●
4	4.5	3.4	M 4	M 6	22	6	4.9	60	8.4	130	FZ111300.04	●
5	6	4.9	M 4.5 - M6	M 8	25	7	5.5	60	12.1	130	FZ111300.05	●
6	7	5.5	M 7	M 9 - M10	25	7	5.5	60	12.1	130	FZ111300.06	●
7	8	6.2	M 8	M11	29	8	6.2	60	13	130	FZ111300.07	●
8	9	7	M 9	M12	30	9	7	60	15	130	FZ111300.08	●
9	10	8	M10	—	32	10	8	60	15	130	FZ111300.09	●
10	11	9	—	M14	35	11	9	90	18	180	FZ111300.10	●
11	12	9	(M12)	M16	35	12	9	90	18	180	FZ111300.11	●
12	14	11	—	M18	39	14	11	90	22	180	FZ111300.12	●
13	16	12	—	M20	40	16	12	90	22	180	FZ111300.13	●
14	18	14.5	—	M22 - M24	42	18	14.5	100	26	200	FZ111300.14	●
15	20	16	—	M27	44	20	16	100	28	200	FZ111300.15	●
16	22	18	—	M30	46	22	18	100	30	200	FZ111300.16	●
17	25	20	—	M33	49	25	20	100	35	200	FZ111300.17	●

For use on CNC machines and conventional thread cutting machinery

Short type with coolant-thru (IKZ)

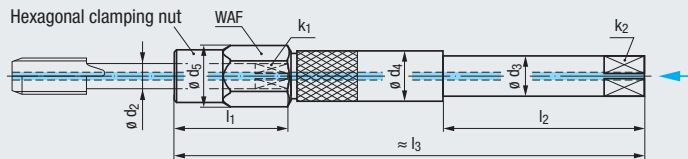

IKZ

p_{max}
700psi
(50bar)

Size	Tap Dimensions				Extension Dimensions						Clamping nut		EDP Number		
	$\varnothing d_2$	k_1			l_1	$\varnothing d_3$ h9	k_2 h12	l_2	$\varnothing d_4$	$\varnothing d_5$	l_3	WAF			M _d ¹⁾ ft lbs
1	2.8	2.1	M 2 - M2.6	M 4	21	6	4.9	60	6.1	6.5	130	6	1.5	FZ112600.01	●
2	3.5	2.7	M 3	M 4.5 - M5	22	6	4.9	60	7.5	9	130	8	1.5	FZ112600.02	●
3	4	3	M 3.5	M 5.5	22	6	4.9	60	8.4	10	130	9	1.8	FZ112600.03	●
4	4.5	3.4	M 4	M 6	22	6	4.9	60	8.4	10	130	9	2.2	FZ112600.04	●
5	6	4.9	M 4.5 - M6	M 8	25	7	5.5	60	12.1	13.5	130	12	2.6	FZ112600.05	●
6	7	5.5	M 7	M 9 - M10	25	7	5.5	60	12.1	13.5	130	12	3.7	FZ112600.06	●
7	8	6.2	M 8	M11	29	8	6.2	60	13	14.5	130	13	4.4	FZ112600.07	●
8	9	7	M 9	M12	30	9	7	60	15	16.5	130	15	5.9	FZ112600.08	●
9	10	8	M10	—	32	10	8	60	15	16.5	130	15	8.1	FZ112600.09	●
10	11	9	—	M14	35	11	9	90	18	20	180	18	11.1	FZ112600.10	●
11	12	9	(M12)	M16	35	12	9	90	18	20	180	18	14.8	FZ112600.11	●
12	14	11	—	M18	39	14	11	90	22	25	180	22	18.4	FZ112600.12	●
13	16	12	—	M20	40	16	12	90	22	25	180	22	24.3	FZ112600.13	●
14	18	14.5	—	M22 - M24	42	18	14.5	100	26	29	200	26	33.2	FZ112600.14	●
15	20	16	—	M27	44	20	16	100	28	32	200	28	44.3	FZ112600.15	●
16	22	18	—	M30	46	22	18	100	30	34	200	30	56.8	FZ112600.16	●
17	25	20	—	M33	49	25	20	100	35	41	200	36	73.8	FZ112600.17	●

¹⁾ Recommend tightening torque

Accessories



Spare clamping nuts

» 139



Torque wrenches

» 140

For use on CNC machines and conventional thread cutting machinery

Long type

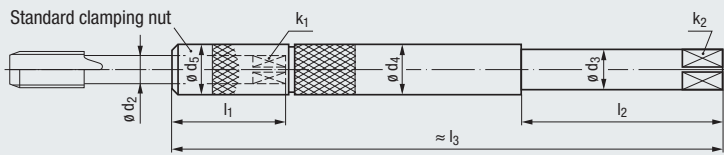

Size	Tap Dimensions				Extension Dimensions						EDP Number	
	ϕd_2	k_1			l_1	ϕd_3 h9	k_2 h12	l_2	$\phi d_4 / d_5$	l_3		
1	2.8	2.1	M 2 - M2.6	M 4	21	6	4.9	65	6.1	230	FZ111310.01	●
2	3.5	2.7	M 3	M 4.5 - M5	22	6	4.9	70	7.5	230	FZ111310.02	●
3	4	3	M 3.5	M 5.5	22	6	4.9	70	8.4	230	FZ111310.03	●
4	4.5	3.4	M 4	M 6	22	6	4.9	70	8.4	230	FZ111310.04	●
5	6	4.9	M 4.5 - M6	M 8	25	7	5.5	70	12.1	230	FZ111310.05	●
6	7	5.5	M 7	M 9 - M10	25	7	5.5	70	12.1	230	FZ111310.06	●
7	8	6.2	M 8	M11	29	8	6.2	80	13	230	FZ111310.07	●
8	9	7	M 9	M12	30	9	7	80	15	230	FZ111310.08	●
9	10	8	M10	-	32	10	8	80	15	230	FZ111310.09	●
10	11	9	-	M14	35	11	9	90	18	330	FZ111310.10	●
11	12	9	(M12)	M16	35	12	9	90	18	330	FZ111310.11	●
12	14	11	-	M18	39	14	11	90	22	330	FZ111310.12	●
13	16	12	-	M20	40	16	12	90	22	330	FZ111310.13	●
14	18	14.5	-	M22 - M24	42	18	14.5	100	26	330	FZ111310.14	●
15	20	16	-	M27	44	20	16	100	28	330	FZ111310.15	●
16	22	18	-	M30	46	22	18	100	30	330	FZ111310.16	●
17	25	20	-	M33	49	25	20	100	35	330	FZ111310.17	●

For use on CNC machines and conventional thread cutting machinery

Long type with coolant-thru (IKZ)

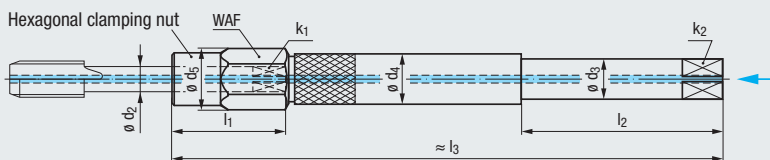

IKZ
p_{max}
700psi
(50bar)

Size	Tap Dimensions				Extension Dimensions						Clamping nut		EDP Number		
	ϕd_2	k_1			l_1	ϕd_3 h9	k_2 h12	l_2	ϕd_4	ϕd_5	l_3	WAF			M _d 1) ft lbs
1	2.8	2.1	M 2 - M2.6	M 4	21	6	4.9	65	6.1	6.5	230	6	1.5	FZ112610.01	●
2	3.5	2.7	M 3	M 4.5 - M5	22	6	4.9	70	7.5	9	230	8	1.5	FZ112610.02	●
3	4	3	M 3.5	M 5.5	22	6	4.9	70	8.4	10	230	9	1.8	FZ112610.03	●
4	4.5	3.4	M 4	M 6	22	6	4.9	70	8.4	10	230	9	2.2	FZ112610.04	●
5	6	4.9	M 4.5 - M6	M 8	25	7	5.5	70	12.1	13.5	230	12	2.6	FZ112610.05	●
6	7	5.5	M 7	M 9 - M10	25	7	5.5	70	12.1	13.5	230	12	3.7	FZ112610.06	●
7	8	6.2	M 8	M11	29	8	6.2	80	13	14.5	230	13	4.4	FZ112610.07	●
8	9	7	M 9	M12	30	9	7	80	15	16.5	230	15	5.9	FZ112610.08	●
9	10	8	M10	-	32	10	8	80	15	16.5	230	15	8.1	FZ112610.09	●
10	11	9	-	M14	35	11	9	90	18	20	330	18	11.1	FZ112610.10	●
11	12	9	(M12)	M16	35	12	9	90	18	20	330	18	14.8	FZ112610.11	●
12	14	11	-	M18	39	14	11	90	22	25	330	22	18.4	FZ112610.12	●
13	16	12	-	M20	40	16	12	90	22	25	330	22	24.3	FZ112610.13	●
14	18	14.5	-	M22 - M24	42	18	14.5	100	26	29	330	26	33.2	FZ112610.14	●
15	20	16	-	M27	44	20	16	100	28	32	330	28	44.3	FZ112610.15	●
16	22	18	-	M30	46	22	18	100	30	34	330	30	56.8	FZ112610.16	●
17	25	20	-	M33	49	25	20	100	35	41	330	36	73.8	FZ112610.17	●

1) Recommend tightening torque

Accessories



Spare clamping nuts

» 139



Torque wrenches

» 140

● = In stock
★ = Allow 7 days for delivery

Product Finder

V_c

UNC

UNF

UNEF

UN-8

MF

NPSM/NPSC

NPSF

R_p (BSPP)

G

NPT

NPTF

R_c (BSPT)

STI

SELF-LOCK

Accessories

Tech. Info



- Product Finder
- V_c
- UNC
- UNF
- UNEF
- UN-8
- M
- MF
- NPSM/NPSC
- NPSF
- Rp (BSPP)
- G
- NPT
- NPTF
- Rc (BSPT)
- STI
- SELF-LOCK
- Accessories
- Tech. Info



For thermic shrinking of carbide tools with h6 shank tolerance

Short type with coolant-thru (IKZ)

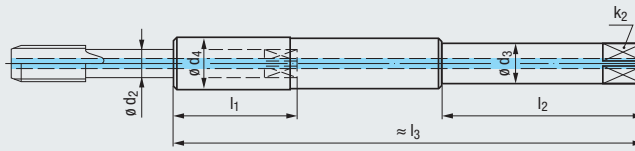

IKZ

p_{max}
700psi
(50bar)

Size	Tap Dimensions		Extension Dimensions						EDP Number	★
	$\varnothing d_2$		l_1	$\varnothing d_3$ h6	k_2 h12	l_2	$\varnothing d_4$	l_3		
5	6	M 4.5 - M6 M 8	31	7	5.5	60	12.1	130	FZ131500.05	★
6	7	M 7 M 9 - M10	31	7	5.5	60	12.1	130	FZ131500.06	★
7	8	M 8 M11	32	8	6.2	60	13	130	FZ131500.07	★
8	9	M 9 M12	33	9	7	60	15	130	FZ131500.08	★
9	10	M10 -	34	10	8	60	15	130	FZ131500.09	★
10	11	- M14	46	11	9	90	18	180	FZ131500.10	★
11	12	(M12) M16	46	12	9	90	18	180	FZ131500.11	★
12	14	- M18	48	14	11	90	22	180	FZ131500.12	★
13	16	- M20	49	16	12	90	22	180	FZ131500.13	★

For thermic shrinking of carbide tools with h6 shank tolerance

Long type with coolant-thru (IKZ)

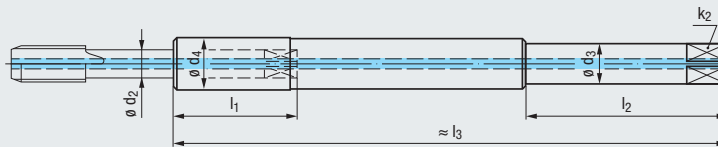

IKZ

p_{max}
700psi
(50bar)

Size	Tap Dimensions		Extension Dimensions						EDP Number	★
	$\varnothing d_2$		l_1	$\varnothing d_3$ h6	k_2 h12	l_2	$\varnothing d_4$	l_3		
5	6	M 4.5 - M6 M 8	31	7	5.5	70	12.1	230	FZ131510.05	★
6	7	M 7 M 9 - M10	31	7	5.5	70	12.1	230	FZ131510.06	★
7	8	M 8 M11	32	8	6.2	80	13	230	FZ131510.07	★
8	9	M 9 M12	33	9	7	80	15	230	FZ131510.08	★
9	10	M10 -	34	10	8	80	15	230	FZ131510.09	★
10	11	- M14	46	11	9	90	18	330	FZ131510.10	★
11	12	(M12) M16	46	12	9	90	18	330	FZ131510.11	★
12	14	- M18	48	14	11	90	22	330	FZ131510.12	★
13	16	- M20	49	16	12	90	22	330	FZ131510.13	★

Standard Clamping Nuts



Inch Sizes		Tool Identification		FZ112110
Size	ø d ₂	Dimens. ID		
101	0.141	.101		★
102	0.168	.102		★
103	0.194	.103		★
104	0.220	.104		★
105	0.255	.105		★
106	0.318	.106		★
107	0.323	.107		★
108	0.367	.108		★
109	0.381	.109		★
110	0.429	.110		★
111	0.480	.111		★
112	0.590	.112		★
113	0.697	.113		★
114	0.800	.114		★
115	0.896	.115		★
116	1.021	.116		★
117	1.108	.117		★
118	1.233	.118		★
150	0.3125	.150		★
151	0.4375	.151		★
152	0.5625	.152		★
153	0.6875	.153		★
154	0.7000	.154		★
155	0.9063	.155		★
156	1.1250	.156		★

Metric Sizes		Tool Identification		FZ112100
Size	ø d ₂	Dimens. ID		
1	2.8	.01		★
2	3.5	.02		★
3	4	.03		★
4	4.5	.04		★
5	6	.05		★
6	7	.06		★
7	8	.07		★
8	9	.08		★
9	10	.09		★
10	11	.10		★
11	12	.11		★
12	14	.12		★
13	16	.13		★
14	18	.14		★
15	20	.15		★
16	22	.16		★
17	25	.17		★

Hexagonal Clamping Nuts



Inch Sizes			Tool Identification		FZ112030	
Size	ø d ₂	WAF	Recommended tightening torque		Dimens. ID	
			ft lbs	Nm		
101	0.141	0.315	1.5	2	.101	★
102	0.168	0.354	2.1	2.8	.102	★
103	0.194	0.472	2.4	3.3	.103	★
104	0.220	0.472	2.6	3.5	.104	★
105	0.255	0.472	3.1	4.2	.105	★
106	0.318	0.512	4.4	6	.106	★
107	0.323	0.512	4.9	6.6	.107	★
108	0.367	0.591	5.9	8	.108	★
109	0.381	0.591	8.1	11	.109	★
110	0.429	0.709	11.1	15	.110	★
111	0.480	0.709	14.8	20	.111	★
112	0.590	0.866	20.7	28	.112	★
113	0.697	1.024	33.2	45	.113	★
114	0.800	1.102	44.3	60	.114	★
115	0.896	1.181	56.8	77	.115	★
116	1.021	1.417	88.5	120	.116	★

Metric Sizes			Tool Identification		FZ112000	
Size	ø d ₂	WAF	Recommended tightening torque		Dimens. ID	
			ft lbs	Nm		
1	2.8	6	1.5	2	.01	★
2	3.5	8	1.5	2	.02	★
3	4	9	1.8	2.5	.03	★
4	4.5	9	2.2	3	.04	★
5	6	12	2.6	3.5	.05	★
6	7	12	3.7	5	.06	★
7	8	13	4.4	6	.07	★
8	9	15	5.9	8	.08	★
9	10	15	8.1	11	.09	★
10	11	18	11.1	15	.10	★
11	12	18	14.8	20	.11	★
12	14	22	18.4	25	.12	★
13	16	22	24.3	33	.13	★
14	18	26	33.2	45	.14	★
15	20	28	44.3	60	.15	★
16	22	30	56.8	77	.16	★
17	25	30	73.8	100	.17	★

- Product Finder
- V_c
- UNC
- UNF
- UNEF
- UN-8
- MF
- NPSM/NPSC
- NPSF
- Rp (BSPP)
- G
- NPT
- NPTF
- Rc (BSPT)
- STI
- SELF-LOCK
- Accessories
- Tech. Info



● = In stock
★ = Allow 7 days for delivery

- Product Finder
- V_c
- UNC
- UNF
- UNEF
- UN-8
- M
- MF
- NPSM/NPSC
- NPSF
- Rp (BSPP)
- G
- NPT
- NPTF
- Rc (BSPT)
- STI
- SELF-LOCK
- Accessories
- Tech. Info

Torque wrenches



MANOSKOP



TORCO-FIX

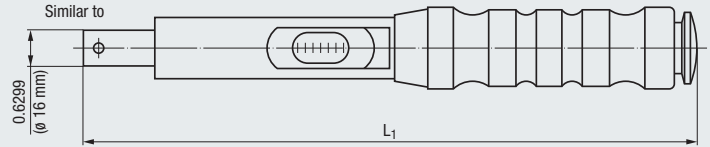

Type	Torque	inch L ₁	EDP Number	
MANOSKOP 730N	1.5 - 15 ft lbs (2 - 20 Nm)	11.890	F0900005	★
TORCO-FIX I	7 - 37 ft lbs (10 - 50 Nm)	13.189	F0908005	★
TORCO-FIX II	30 - 148 ft lbs (40 - 200 Nm)	18.307	F0908020	★

Type	Size for Special Shank Extension	MANOSKOP/ TORCO-FIX	inch		EDP Number	
			A	B		
A-SW 6	01	730N	0.650	2.087	F0908500.06	★
A-SW 8	02	730N	0.807	2.165	F0908500.08	★
A-SW 9	03, 04	730N	0.807	2.165	F0908500.09	★
A-SW 12	05, 06	730N	1.142	2.244	F0908500.12	★
A-SW 13	07	730N	1.358	2.323	F0908500.13	★
A-SW 15	08, 09	730N	1.358	2.323	F0908500.15	★
A-SW 18	10, 11	I	1.634	2.323	F0908500.18	★
A-SW 22	12, 13	I	2.205	2.520	F0908500.22	★
A-SW 26	14	II	2.205	2.520	F0908500.26	★
A-SW 28	15	II	2.677	2.559	F0908500.28	★
A-SW 30	16	II	2.677	2.559	F0908500.30	★
A-SW 36	17	II	2.677	2.559	F0908500.36	★

Shell-type wrenches

A-SW

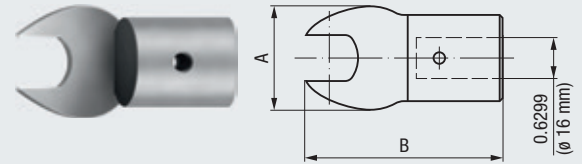

Technical Information

		Page
1.1	General technical information regarding EMUGE threading tools	142
1.2	Dimensions and technical sales conditions	142
1.3	Constructional designs of our EMUGE taps	142
1.4	Special tap types (examples)	143
1.5	Basic types of our EMUGE taps	144 - 145
1.6	Our EMUGE geometries	145 - 146
1.7	Our EMUGE surface treatments and coatings	147
1.8	Other EMUGE abbreviations	148
1.9	Chamfer forms	149
1.10	Cooling and lubrication agents	149
1.11	Tolerance chart – UNC/UNF	150
1.12	Tolerance chart – Metric coarse/fine	151
1.13	Tolerance chart – Oversize 6G taps	151
1.14	Tolerance zones of the pitch diameter on the Unified thread (graphic representation)	152
1.15	Tolerance zones of the pitch diameter on the Metric thread (graphic representation)	152
1.16	Recommended tap drill sizes for tapping internal threads	153 - 158
1.17	Decimal equivalents for tap drill selection	159
1.18	Conversion table SFM to RPM for taps	160
1.19	Troubleshooting guide for tapping	161

Product
FinderV_c

UNC

UNF

UNEF

UN-8

...

MF

NPSM/NPSC

NPSF

Rp (BSPP)

G

NPT

NPTF

Rc (BSPT)

STI

SELF-LOCK

Accessories

Tech. Info



- Product Finder
- V_c
- UNC
- UNF
- UNEF
- UN-8
- M
- MF
- NPSM/NPSC
- NPSF
- Rp (BSPP)
- G
- NPT
- NPTF
- Rc (BSPT)
- STI
- SELF-LOCK
- Accessories
- Tech. Info**

1.1 General technical information regarding EMUGE threading tools

EMUGE threading tools are made exclusively of high-performance high-speed steels according to EMUGE specifications. Our modified tool steels are based on the material alloy group HSSE acc. DIN ISO 11054.

As for tools which are designed for a special application, these generally used tool materials do not come up to our requirements. In such cases we use special high-speed steel alloys and carbide materials which are specially selected for the work case in question. A rigorous quality control of these materials forms the basis of our high-quality tools. Research and development work is carried out in a specially equipped laboratory, and serves as an indispensable precondition for the further development of cutting geometries and other parameters necessary for thread production. Extensive tests and trials on CNC machines, conventional drilling and thread cutting machines guarantee the performance and economic efficiency of our tools.

1.3 Constructional designs of our EMUGE taps

1.2 Dimensions and technical sales conditions

The dimensional specifications of our threading tools are adjusted to the currently valid standards, with the exception of special tools made to EMUGE standards.





The DIN standards for taps are based on the General Plans of Dimensions for Taps acc. DIN 2184-1 and -2.

Please read the notes in this catalog and in the technical introduction carefully.

The technical sales conditions for taps acc. DIN 2197 and roll form taps acc. DIN 2175 have been taken into account.

The manufacturing tolerances for the thread part are in accordance with DIN EN 22857 and DIN 802.

All specifications, illustrations and dimensions are subject to change due to technical progress and possible changes of the standards, and are consequently without obligation.

	Constructional design	EMUGE designation
	Hand taps, short machine taps	Rekord Enorm
	Machine taps with reinforced shank	Rekord 1 Enorm 1
	Machine taps with reduced shank	Rekord 2 Enorm 2 Robust 2X
	Machine taps with long flutes and long shank	LF
	Machine taps with extra long shank	LS

1.4 Special tap types (examples)

Special taps to customers' specifications

EMUGE produces special taps to customers' drawings and proper specifications.

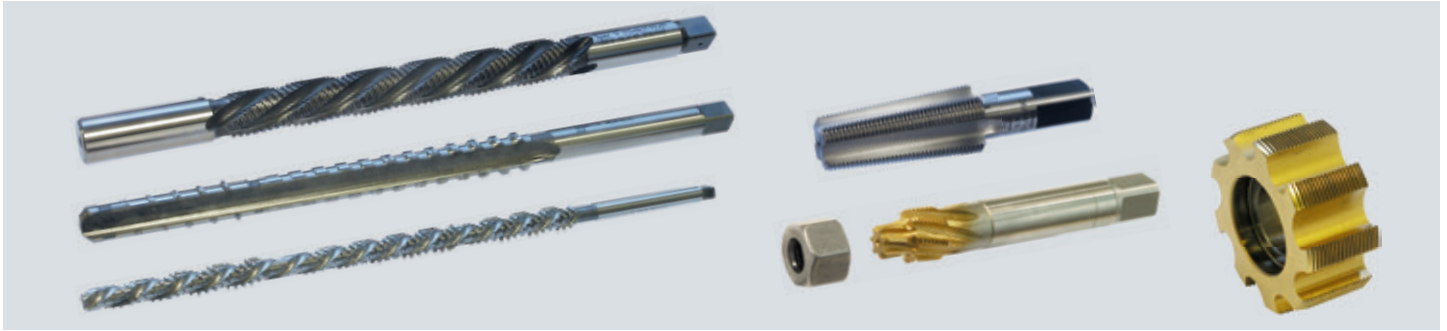

Special threads (examples)

GL

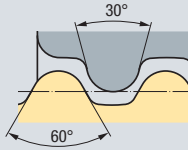

Cylindrical round thread
acc. DIN 168-1

FG

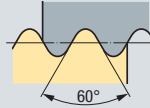

Bicycle thread
acc. DIN 79012

Vg

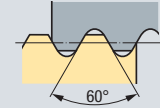

Valve thread
acc. DIN 7756

MFS

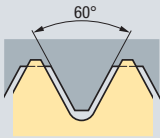

ISO Metric thread for tight fit
acc. DIN 8141-1

ST



Sheet metal screw thread
acc. DIN EN ISO 1478

A/B

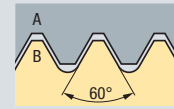

Tripod connection thread
acc. DIN 4503

Tr

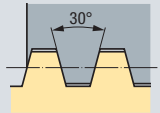

Flat ISO metric trapezoidal thread
(one-start and multi-start) acc. DIN 380-1 and -2

GEWI

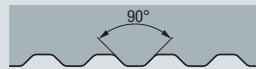

Special profile

E

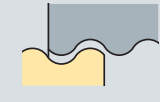

Electrical thread
acc. DIN 40400

S

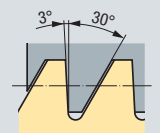

Metric buttress thread (one-start and multi-start)
acc. DIN 513-1 to -3

M

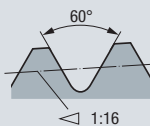

Metric tapered external thread
acc. DIN 158-1

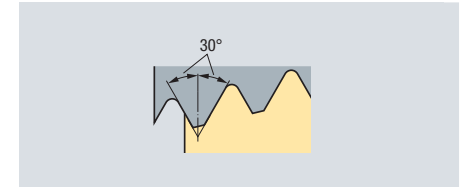

Thread for wire release connection
acc. DIN 19004

Product
Finder

V_c

UNC

UNF

UNEF

UN-8

...

MF

NPSM/NPSC

NPSF

Rp (BSPP)

G

NPT

NPTF

Rc (BSPT)

STI

SELF-LOCK

Accessories

Tech. Info



- Product Finder
- V_c
- UNC
- UNF
- UNEF
- UN-8
- M
- MF
- NPSM/NPSC
- NPSF
- Rp (BSPP)
- G
- NPT
- NPTF
- Rc (BSPT)
- STI
- SELF-LOCK
- Accessories

1.5 Basic types of our EMUGE taps

Rekord A

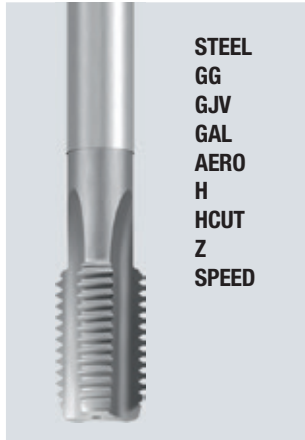

STEEL
GG
GJV
GAL
AERO
H
HCUT
Z
SPEED

- Straight flutes
- Chamfer form C (2-3 threads)
- Chamfer form E (1.5-2 threads)
- For blind hole and through hole threads

Note:
Especially for short-chipping material. The flutes can hold only a part of the chips. There is practically no chip transport in an axial direction. We do not recommend using this tap type in deep blind hole or through hole threads in long-chipping material.

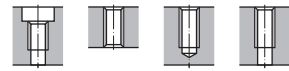

Rekord B

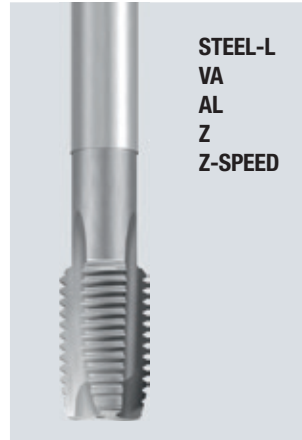

STEEL-L
VA
AL
Z
Z-SPEED

- Straight flutes with spiral point
- Chamfer form B (4-5 threads)
- For through hole threads

Note:
Typical tool for through hole threads in long-chipping material. The spiral point pushes the tightly rolled chips ahead and prevents clogging of the flutes. Coolant-lubricant can flow freely. Do not use this tap type for a reverse cut!

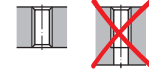

Rekord C

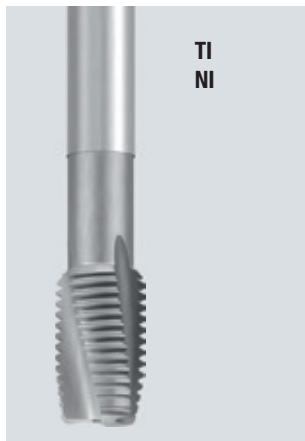

TI
NI

- 8-15° left-hand spiral flutes
- Chamfer form D (4-5 threads)
- For through hole threads

Note:
The left-hand spiral flutes push the chips ahead. As opposed to the spiral-point design (Rekord B), the rake angle remains constant over the complete length of the chamfer. This means extremely stable chamfer teeth for high-strength materials.



Rekord D

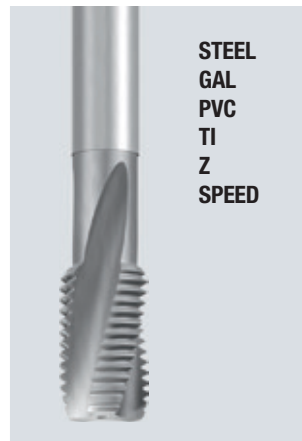

STEEL
GAL
PVC
TI
Z
SPEED

- 10-15° right-hand spiral flutes
- Chamfer form E (1.5-2 threads)
- Chamfer form C (2-3 threads)
- For blind hole threads

Note:
Especially to be recommended on automatic lathes and multi-spindle machines. The slow spiral flutes will be especially helpful in thread holes beginning with an increased diameter (counterbore or enlarged bore). Provided with internal coolant supply, this tap type will help to solve chip problems on CNC machines.

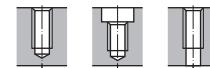

Rekord DF

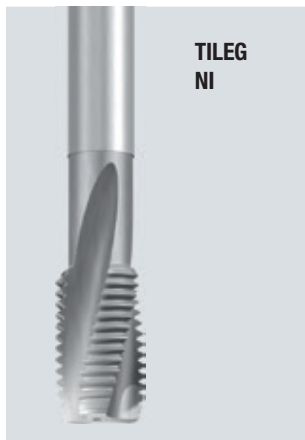

TILEG
NI

- 10-15° right-hand spiral flutes
- Additional helix correction "F" (relief)
- Chamfer form C (2-3 threads)
- For blind hole threads

Note:
Especially to be recommended on automatic lathes and multi-spindle machines. The slow spiral flutes will be especially helpful in thread holes beginning with an increased diameter (counterbore or enlarged bore). The additional helix correction "F" (relief) produces smaller, and tightly rolled chips. Provided with internal coolant supply, this tap type will help to solve chip problems on CNC machines.

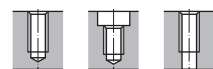

Enorm

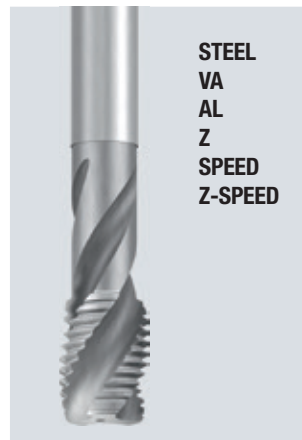

STEEL
VA
AL
Z
SPEED
Z-SPEED

- 35-50° right-hand spiral flutes
- Chamfer form E (1.5-2 threads)
- Chamfer form C (2-3 threads)
- For blind hole threads in long-chipping materials

Note:
Typical tool for blind hole threads in long-chipping materials. The fast spiral flutes provide good chip removal from the blind hole. Depending on design and size, threads up to 3 x d₁ can be cut. Not to be recommended for threads beginning with an increased diameter.

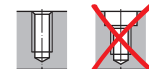

1.5 Basic types of our EMUGE taps

Robust 2X



VA

- Provided with a hollow face
- Chamfer form C (2-3 threads)
- For blind hole and through hole threads

Note:

The special crown-shaped front portion of this tool provides excellent accuracy even in the first stage of the cutting process. Extra clean and accurate threads can be cut in this way. The swarf is collected in the hollow face of the tap (internal chip collector) when cutting blind hole threads. For this tool, we recommend using paste lubrication wherever possible. Please make sure to cover not only the tool but also the walls of the hole with paste!

Oil lubrication is possible only in vertical machining, if the blind hole can be completely filled with oil.

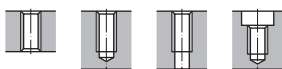

1.6 Our EMUGE geometries

EMUGE
—STEEL—
Rekord A
Rekord B
Rekord D
Enorm
For steel materials

Geometry with very good proper guidance for true-to-gauge thread cutting on all machines. Available ex stock in many thread systems and sizes. By combination with hard surface coatings, cutting data and tool life increases can be achieved.

- **Rekord B-STEEL-L**
For low strength steels

EMUGE
—VA—
Rekord B
Enorm
For stainless steel materials and steel materials

With tough and long-chipping materials, the chips must be transported in an axial direction in order to avoid chip jams. An increased profile relief angle reduces friction and with it, the danger of cold welding.

EMUGE
—GG—
Rekord A
For cast iron

Since cast iron is a very abrasive material, these taps are always provided with a surface treatment in addition to a low rake angle. In general, straight flutes are sufficient for such short-chipping materials.

EMUGE
—GJV—
Rekord A
For cast iron with vermicular graphite

Newly developed cast materials often show very special grain structures. In combination with an increased number of flutes and a specially adjusted geometry, these tools permit long tool life even in these highly abrasive materials as well as in normal cast iron.

EMUGE
—AL—
Rekord B
Enorm
For aluminum wrought alloys

In the machining of long-chipping aluminum, it is absolutely necessary to provide chip transport in an axial direction. In addition to the large rake angle, these tools are made with a reduced number of flutes so that there is even more room for the swarf. This helps to avoid clogging of the flutes.

EMUGE
—GAL—
Rekord A
Rekord D
For aluminum cast alloys

In order to achieve a long tool life in this highly abrasive material, all the tools are provided with a hard surface coating. Internal coolant supply also is very helpful.

Product
FinderV_c

UNC

UNF

UNEF

UN-8

...

MF

NPSM/NPSC

NPSF

Rp (BSPP)

G

NPT

NPTF

Rc (BSPT)

STI

SELF-LOCK

Accessories

Tech. Info



- Product Finder
- V_c
- UNC
- UNF
- UNEF
- UN-8
- M
- MF
- NPSM/NPSC
- NPSF
- Rp (BSPP)
- G
- NPT
- NPTF
- Rc (BSPT)
- STI
- SELF-LOCK
- Accessories
- Tech. Info

1.6 Our EMUGE geometries

 <p>Rekord D</p>	<p>For long-chipping synthetics</p> <p>The chamfer of this tool has been optimized in order to ensure a safe shearing off of the chip root in the thread. An elevated tolerance, combined with a hard surface coating, guarantees true-to-gauge threads in these elastic materials.</p>	<p>AERO</p> <p>Rekord B</p>	<p>For tough materials with high tensile strength</p> <p>Negative rake angle values gives a very strong cutting edge. Especially in tough materials with high tensile strength this will lead to a safe tapping process.</p>
 <p>Rekord C Rekord D</p>	<p>For titanium</p> <p>These alloys are usually very strong, long-chipping and clamping. Small rake angles and very high relief angles are necessary. Often, it is necessary also to specially adjust the tool to the individual alloy and the specific work conditions.</p>	 <p>Rekord DF</p>	<p>For titanium alloys</p> <p>Titanium alloys are becoming more and more popular in modern industry. The geometry of this tool has been specially adjusted to the machining of these materials. Cold welding is prevented by the extra high relief angle values. A helix correction provides short chips.</p>
 <p>Rekord C Rekord DF</p>	<p>For nickel alloys</p> <p>Nickel alloys are usually very tough, clamping and of high tensile strength, e.g. Inconel 718. Negative rake angles, very high relief angles and a hard surface coating are an unconditional necessity. Lubrication with paste or oil is necessary in most cases.</p>	 <p>Rekord A</p>	<p>For materials of high tensile strength</p> <p>Relatively high relief angle values in combination with a surface treatment or a hard surface coating ensure extra long tool life in abrasive materials.</p>
 <p>Rekord A</p>	<p>For hardened steels</p> <p>This geometry with its specially adjusted flute profiles and its special rake and relief angles makes thread cutting in hardened steel possible. Made of cutting material HSS-E-PM, these tools are suitable for a material hardness of 44-55 HRC, while solid carbide tools will work in a hardness of 55-63 HRC.</p>	 <p>Rekord A Rekord B Rekord D Enorm</p>	<p>For CNC-controlled machines</p> <p>This very keen cutting geometry with elevated rake and relief angles is suitable for a multitude of long-chipping materials. It is designed especially for CNC-controlled machine tools. Synchronous feed control, especially in connection with our collet holders of the Softsynchro® series, will bring out the full performance potential of these tools.</p>
 <p>Rekord A Rekord B Rekord D Enorm</p>	<p>For high-speed tapping</p> <p>CNC machines, especially in combination with our Speedsynchro®, make very high speeds possible. The special geometry of these tools, combined with a hard surface coating, offers you the chance to do your machining at the highest speeds your machine can manage.</p>		

1.7 Our EMUGE surface treatments and coatings

NE2

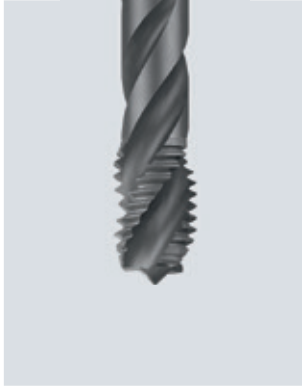
**Oxidation**

In a special installation, the tools are exposed to hot steam. This leads to the formation of a dark oxide layer on the tool surface. This oxide layer protects the surface, and acts as a good carrier of lubricants. Cold welding which occurs especially with low-carbon, soft steels, can be prevented in this way.

NT

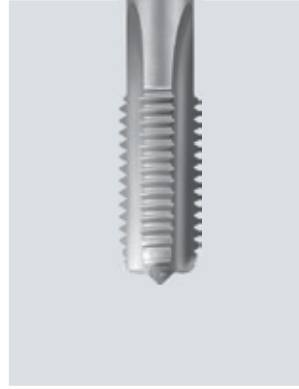
**Nitriding**

In a thermo-chemical treatment, the surface is enriched with nitrogen to a depth of approx. 0.03 to 0.05 mm. Since the surface becomes very hard (1000-1250 HV) and brittle, nitrided tools can be used with certain restrictions only in blind holes and in all work cases which necessitate reversing. In abrasive materials like cast iron, spheroidal cast iron, cast aluminum and duroplastics, tool life can be increased in a decisive manner.

NT2

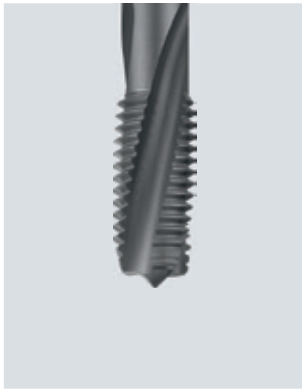
**Nitriding and oxidation**

The surface of the tools is first nitrided and then oxidized (NT + NE2). This treatment combines increased surface hardness with an improved lubricant-holding capacity.

TIN

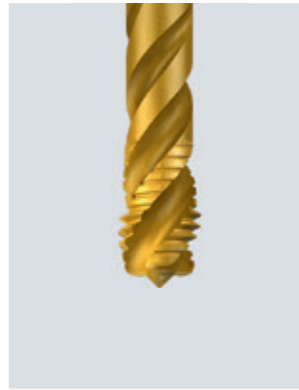
**Titanium nitride (gold-yellow)**

In a PVD process (500 °C) a coating thickness of 3-7 µm can be realized. The coatings feature a high adhesion strength and TIN-typical properties against cold welding.

TIN coating systems with additional code number (e.g. TIN-60, TIN-70) are optimized with regard to substrate and application.

TICN

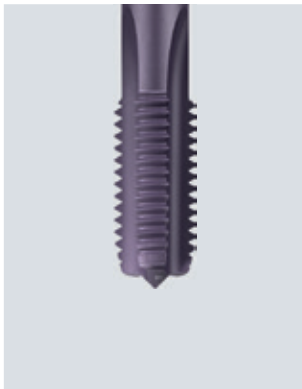
**Titanium carbonitride (blue-grey)**

In a PVD process (500 °C) a coating thickness of 2-4 µm can be realized. The hardness is approx. 3000 HV. The TICN coating will resist up to approx. 400 °C.

GLT-1

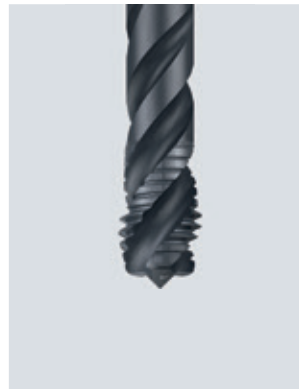
**Hard surface coating with anti-friction layer (dark-grey)**

In a PVD process (500 °C) a coating thickness of 2-4 µm can be realized. The combination of a hard surface coating (approx. 3000 HV) with a superimposed anti-friction layer yields decisive tool life advantages. Also, the chip flow can be very positively influenced.

Please note:

Before re-coating, tools need to be de-coated!

GLT-8

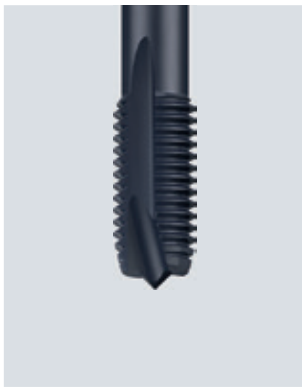
**Diamond-like, amorphous carbon coating (black-grey)**

In a PVD process a coating thickness of 1-2 µm can be realized. The hardness is approx. 2500 HV. This mono-layer coating is an excellent choice for the machining of non-ferrous metals and aluminum with a low silicon content (< 7% Si). Thanks to the low friction, material adhesion is drastically reduced. This coating will remain resistant up to approx. 350 °C.

CRN

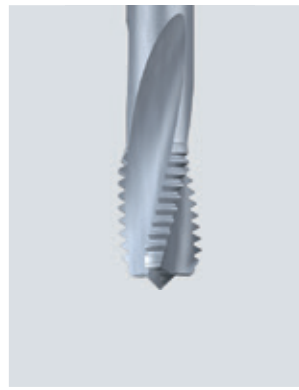
**Chromium nitride (silver-grey)**

In a PVD process (500 °C) coating thicknesses of up to 6 µm can be realized. With a hardness of 1750 HV, the excellent sliding properties will help to achieve long tool life in non-ferrous metals and thermoplastics (even at high temperatures).

Product
FinderV_c

UNC

UNF

UNEF

UN-8

UN-11

MF

NPSM/NPSC

NPSF

Rp (BSPP)

G

NPT

NPTF

Rc (BSPT)

STI

SELF-LOCK

Accessories

Tech. Info



- Product Finder
- V_c
- UNC
- UNF
- UNEF
- UN-8
- M
- MF
- NPSM/NPSC
- NPSF
- Rp (BSPP)
- G
- NPT
- NPTF
- Rc (BSPT)
- STI
- SELF-LOCK
- Accessories
- Tech. Info

1.8 Other EMUGE abbreviations

AZ



With alternating teeth
With “alternating teeth”, flank friction can be reduced. Coolant-lubricant can flow freely between the friction partners.

X

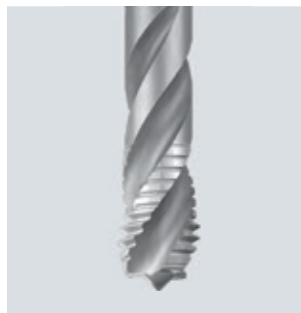

With back taper
Tooth chipping due to chip jams can be prevented by grinding off the tooth crests in the guide thread area.

BF

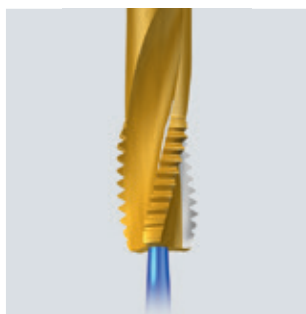

With bright face
“Bright Face” grinding in combination with a special edge preparation ensures that chips will break in steel materials. Short chips will be evacuated without “birdnesting”.

IKZ



Internal coolant supply, axial (DIN designation: KA)
The axial exit of coolant-lubricant provides optimum cooling and lubrication in the chamfer area. Chips are evacuated easily from blind holes.

IKZN

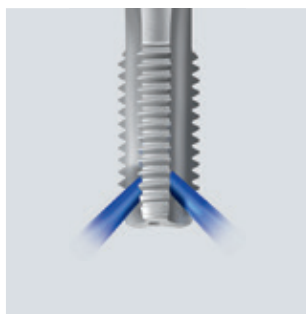

Internal coolant supply, axial, with coolant exiting in the flutes (DIN designation: KR)
Radial exit of coolant-lubricant is the safest solution for providing coolant supply in the chamfer area even in through holes.

LF

Machine taps with long flutes and long shank

Depending on the workpiece material, thread depths of up to $4 \times d_1$ can be achieved with the extended thread part and the long flutes.



LS

Machine taps with extra long shank

Threads with bad access can be easily machined with these tools.



VHM

Solid carbide

Tools with a thread diameter < 12.0 mm are made of solid carbide (thread part and shank).

KHM

Solid carbide head

With tools with a thread diameter ≥ 12.0 mm, the head, or thread part, is made of solid carbide, the shank of tool steel.

LH

Left-hand thread

Left-hand taps are mirror-image designs of the right-hand taps.

1.9 Chamfer forms

Chamfer forms and chamfer lengths for taps acc. DIN 2197.

Form A

Chamfer length 6-8 threads

For straight flutes

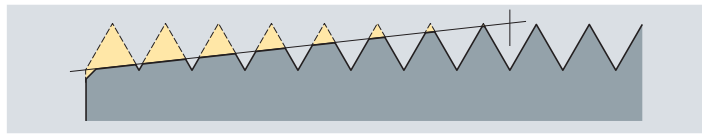

Form C

Chamfer length 2-3 threads

For straight or spiral flutes

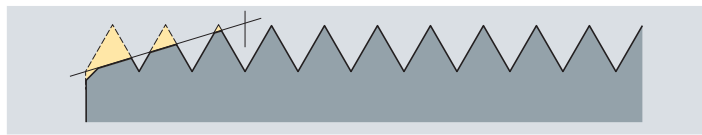

Form E

Chamfer length 1.5-2 threads

For straight or spiral flutes

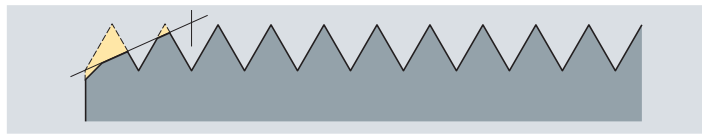

Form B

Chamfer length 3.5-5.5 threads

For straight flutes with spiral point

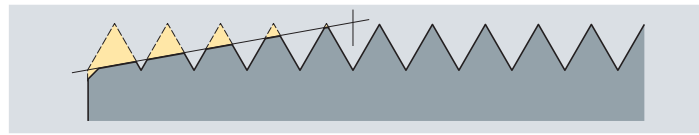

Form D

Chamfer length 3.5-5 threads

For straight or spiral flutes

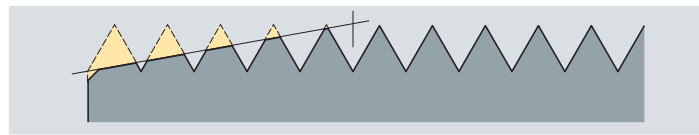

Form F

Chamfer length 1-1.5 threads

For straight or spiral flutes

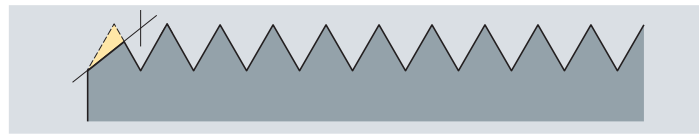

The chamfer length of our EMUGE taps is adjusted to the workpiece material in each individual case.

1.10 Cooling and lubrication agents

Lubricants are often, if not generally, given too little consideration. If you want to get the best performance out of your tool you have to take care to use the best coolant-lubricant available.

In general, we distinguish the following types of cooling and lubrication:

A

Dry machining, pressurized air, cold pressurized air

"Real" dry machining is mostly used only in cast iron. Pressurized air, sometimes cooled, is used in some cases for chip removal.

E

Emulsion

The most common type of coolant-lubricant on machining centres.

O

Thread cutting oil

With these oils which are perfectly adjusted to specific materials, excellent thread surfaces and tool life can be achieved.

M

Minimum-quantity lubrication (MQL)

Due to the more and more common option of supplying aerosol through the spindle on modern machining centres, this type of cooling and lubrication is gaining more and more popularity.

P

Thread cutting paste

Perfectly suitable for the cold forming of threads. Especially useful in horizontal machining, with large thread sizes and through hole threads. To be used only for brush lubrication.



Product Finder

V_c

UNC

UNF

UNEF

UN-8

M

MF

NPSM/NPSC

NPSF

Rp (BSPP)

G

NPT

NPTF

Rc (BSPT)

STI

SELF-LOCK

Accessories

Tech. Info



- Product Finder
- V_c
- UNC
- UNF
- UNEF
- UN-8
- M
- MF
- NPSM/NPSC
- NPSF
- Rp (BSPP)
- G
- NPT
- NPTF
- Rc (BSPT)
- STI
- SELF-LOCK
- Accessories
- Tech. Info

1.11 Tolerance chart – UNC/UNF

EMUGE has determined that the tolerance of the tap should be manufactured as close as possible to the finished internal thread tolerance.

This practice ensures that the threads produced will comply to the gage tolerances providing that the working conditions such as machine, chucking tools, and workpiece match the application.

EMUGE taps are marked with the appropriate tolerance class for their intended use. The U.S. GH thread class numbers are not marked on the tap.

Tolerances for the various GH numbers are shown in the chart opposite.

Classification for the tolerance 1B can be provided upon request.

Taps for cast iron and titanium tapping are designed one GH class higher to provide better tool life.

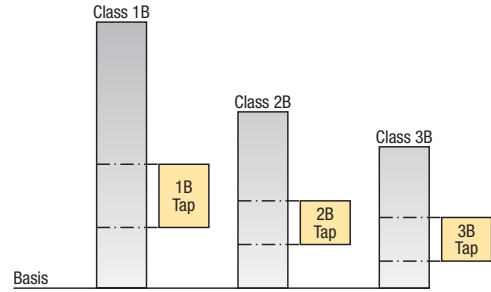

UNC Thread	Tap Limit	
	3B (Tap)	2B (Tap)
No. 1 - 64	H1 / H2	H2 / H3
No. 2 - 56	H1 / H2	H2 / H3
No. 3 - 48	H1 / H2	H2 / H3
No. 4 - 40	H2	H2 / H3
No. 5 - 40	H2	H2 / H3
No. 6 - 32	H2	H3 / H4
No. 8 - 32	H2	H3 / H4
No. 10 - 24	H2 / H3	H3 / H4
No. 12 - 24	H2 / H3	H3 / H4
1/4 - 20	H3	H4 / H5
5/16 - 18	H3	H4 / H5
3/8 - 16	H3 / H4	H4 / H5
7/16 - 14	H3 / H4	H4 / H5
1/2 - 13	H4	H5 / H6
9/16 - 12	H4	H5 / H6
5/8 - 11	H4	H5 / H6
3/4 - 10	H4 / H5	H6 / H7
7/8 - 9	H4 / H5	H6 / H7
1 - 8	H5	H6 / H7
1 1/8 - 7	H5	H7 / H8
1 1/4 - 7	H5 / H6	H7 / H8
1 3/8 - 6	H6	H7 / H8
1 1/2 - 6	H6	H7 / H8
1 3/4 - 5	H6 / H7	H8 / H9
2 - 4 1/2	H7	H8 / H9

UNF Thread	Tap Limit	
	3B (Tap)	2B (Tap)
No. 0 - 80	H1	H1 / H2
No. 1 - 72	H1 / H2	H2 / H3
No. 2 - 64	H1 / H2	H2 / H3
No. 3 - 56	H1 / H2	H2 / H3
No. 4 - 48	H2	H2 / H3
No. 5 - 44	H2	H2 / H3
No. 6 - 40	H2	H2 / H3
No. 8 - 36	H2	H2 / H3
No. 10 - 32	H2	H2 / H3
No. 12 - 28	H2 / H3	H3 / H4
1/4 - 28	H2 / H3	H3 / H4
5/16 - 24	H3	H3 / H4
3/8 - 24	H3	H3 / H4
7/16 - 20	H3	H4 / H5
1/2 - 20	H3	H4 / H5
9/16 - 18	H3 / H4	H4 / H5
5/8 - 18	H3 / H4	H5 / H6
3/4 - 16	H4	H5 / H6
7/8 - 14	H4	H5 / H6
1 - 12	H4 / H5	H5 / H6
1 1/8 - 12	H4 / H5	H6 / H7
1 1/4 - 12	H4 / H5	H6 / H7
1 3/8 - 12	H4 / H5	H6 / H7
1 1/2 - 12	H4 / H5	H6 / H7

1.12 Tolerance chart – Metric coarse/fine

The approved tap tolerance system for metric ISO threads is International Standard ISO 2857.

4H tap corresponds to ISO 1

6H tap corresponds to ISO 2

6G tap corresponds to ISO 3

4H and 6G taps can be supplied upon request. 6G taps are Oversize.

Please refer to the Au “G” values table below.

The U.S. GD tap class numbers are not marked on our taps.

Taps for cast iron and titanium tapping are designed one GH class higher to provide better tool life.

For the special tolerance “7G”, an oversize of approx. 2 x Au “G” has been taken into account.

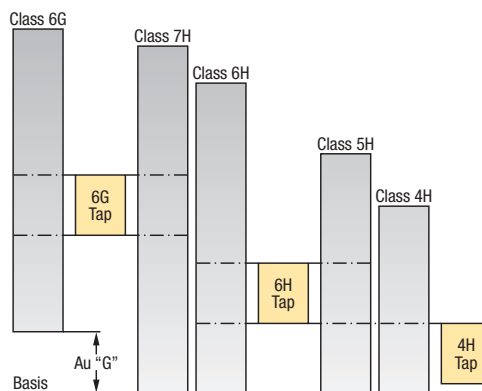

Metric Coarse Thread	Pitch	Tap Tolerance	
		4H	6H
M 1.6	0.35	D2	D2 / D3
M 1.8	0.35	D2	D2 / D3
M 2	0.4	D2	D3
M 2.2	0.45	D2	D3
M 2.5	0.45	D2	D3
M 3	0.5	D2	D3
M 3.5	0.6	D2	D3 / D4
M 4	0.7	D2 / D3	D3 / D4
M 4.5	0.75	D2 / D3	D3 / D4
M 5	0.8	D2 / D3	D3 / D4
M 6	1	D2 / D3	D4 / D5
M 7	1	D2 / D3	D4 / D5
M 8	1.25	D3	D4 / D5
M 10	1.5	D3	D4 / D5
M 12	1.75	D3 / D4	D5 / D6
M 14	2	D3 / D4	D5 / D6
M 16	2	D3 / D4	D5 / D6
M 18	2.5	D4	D6 / D7
M 20	2.5	D4	D6 / D7
M 22	2.5	D4	D6 / D7
M 24	3	D4 / D5	D7 / D8
M 27	3	D4 / D5	D7 / D8
M 30	3.5	D4 / D5	D7 / D8
M 33	3.5	D4 / D5	D8 / D9
M 36	4	D5	D8 / D9
M 39	4	D5	D8 / D9
M 42	4.5	D5	D8 / D9
M 45	4.5	D5	D8 / D9
M 48	5	D5 / D6	D9 / D10
M 52	5	D5 / D6	D9 / D10

Metric Fine Thread (choice)	Tap Tolerance	
	4H	6H
M 3 x 0.35	D2	D3
M 4 x 0.5	D2	D3
M 6 x 0.5	D2 / D3	D3 / D4
M 6 x 0.75	D2 / D3	D4
M 8 x 0.75	D2 / D3	D4
M 8 x 1	D3	D4 / D5
M 12 x 1	D3	D4 / D5
M 10 x 1.25	D3	D4 / D5
M 14 x 1.25	D3	D4 / D5
M 12 x 1.5	D3 / D4	D5 / D6
M 20 x 1.5	D3 / D4	D5 / D6
M 24 x 1.5	D3 / D4	D5 / D6
M 42 x 1.5	D3 / D4	D5 / D6
M 18 x 2	D3 / D4	D6 / D7
M 24 x 2	D4	D6 / D7
M 42 x 2	D4	D6 / D7
M 36 x 3	D4 / D5	D7 / D8
M 42 x 3	D4 / D5	D7 / D8
M 52 x 3	D4 / D5	D7 / D8

1.13 Tolerance chart – Oversize 6G taps

Au “G” Values for Oversize Taps “6G Taps”

Pitch	Tap Tolerance	
	mm	inch
0.35 - 0.4	0.019	.00075
0.45 - 0.5	0.020	.00079
0.6	0.021	.00083
0.7 - 0.75	0.022	.00087
0.8	0.024	.00094
1	0.026	.0010
1.25	0.028	.0011
1.5	0.032	.0013
1.75	0.034	.0013
2	0.038	.0015
2.5	0.042	.0017
3	0.048	.0019
3.5	0.053	.0021
4	0.060	.0024
4.5	0.063	.0025
5	0.071	.0028

Product
FinderV_c

UNC

UNF

UNEF

UN-8

M

MF

NPSM/NPSC

NPSF

Rp (BSPP)

G

NPT

NPTF

Rc (BSPT)

STI

SELF-LOCK

Accessories

Tech. Info



- Product Finder
- V_c
- UNC
- UNF
- UNEF
- UN-8
- M
- MF
- NPSM/NPSC
- NPSF
- Rp (BSPP)
- G
- NPT
- NPTF
- Rc (BSPT)
- STI
- SELF-LOCK
- Accessories
- Tech. Info

1.14 Tolerance zones of the pitch diameter on the Unified thread (graphic representation)

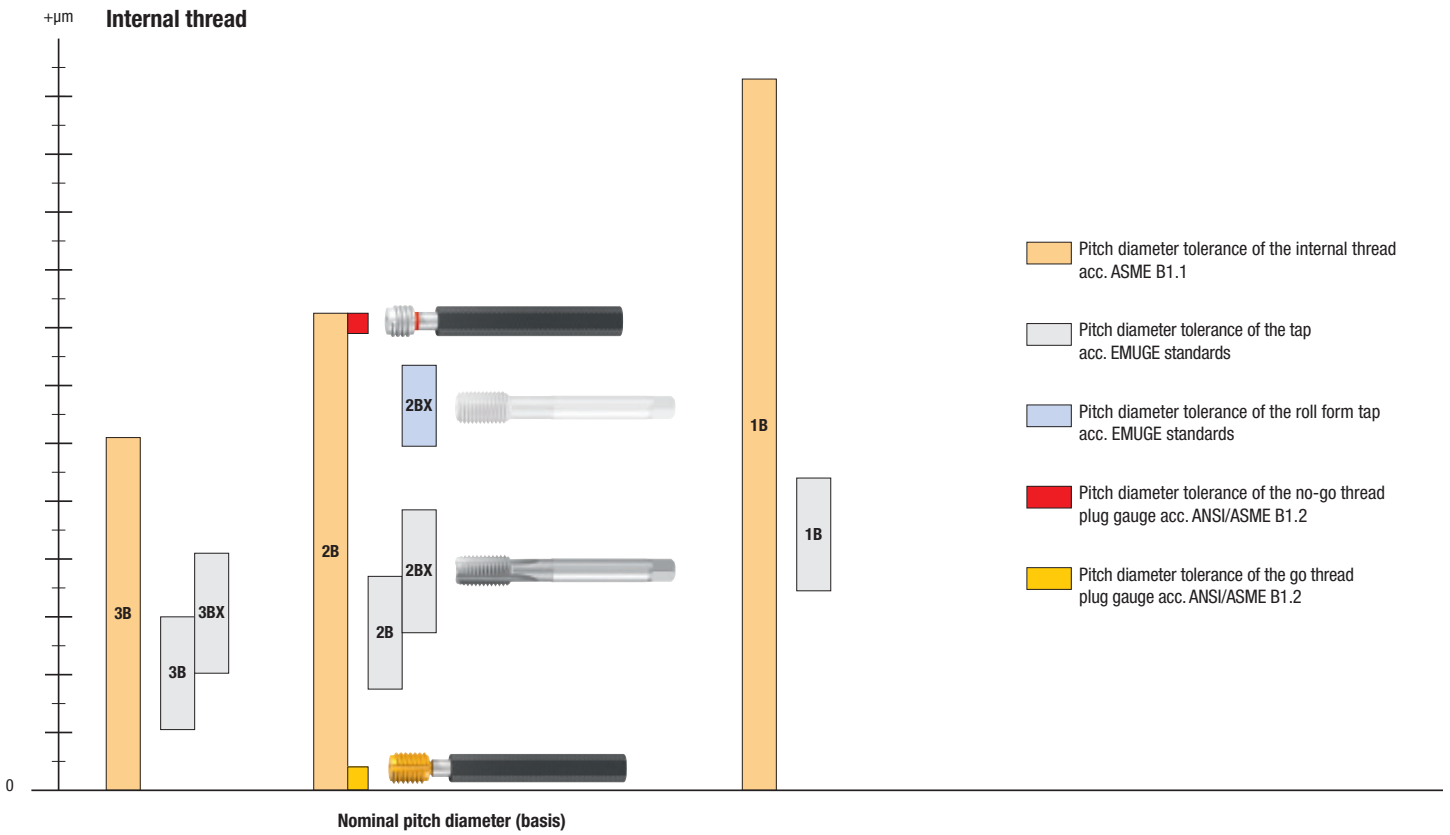

1.15 Tolerance zones of the pitch diameter on the Metric thread (graphic representation)

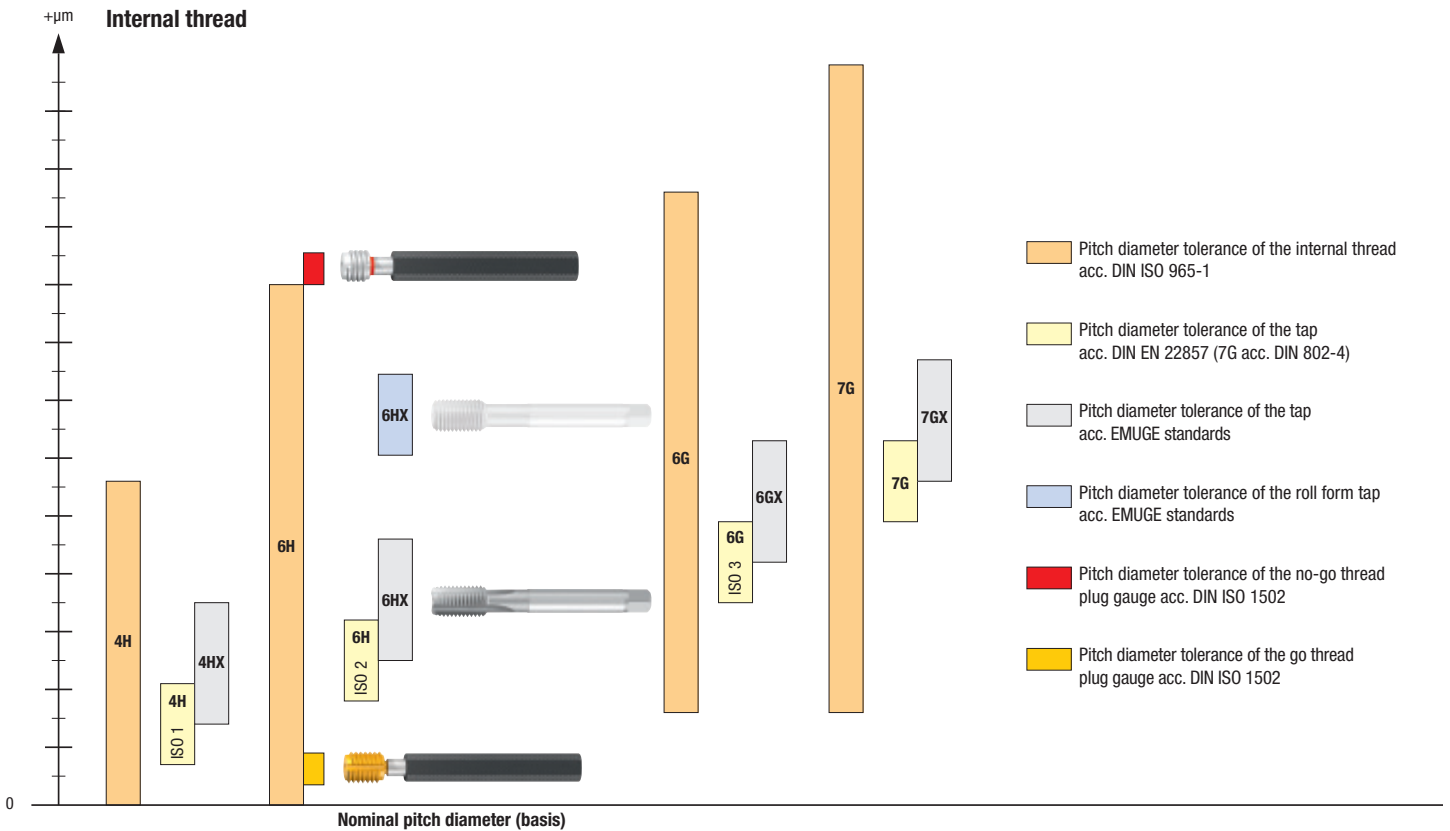

1.16 Recommended tap drill sizes for tapping internal threads

UNC

Unified coarse thread
ASME B1.1, Table 2

Nominal Size	P [T.P.I.]	Minor thread dia. of the internal thread (Tol. 2B)		Rec. tap drill size
		D ₁ min.	D ₁ max.	
No. 1 (0.073)	64	0.0561	0.0622	0.0595
No. 2 (0.086)	56	0.0667	0.0737	0.0700
No. 3 (0.099)	48	0.0764	0.0845	0.0820
No. 4 (0.112)	40	0.0849	0.0939	0.0890
No. 5 (0.125)	40	0.0979	0.1062	0.1015
No. 6 (0.138)	32	0.1040	0.1140	0.1110
No. 8 (0.164)	32	0.1300	0.1390	0.1360
No. 10 (0.190)	24	0.1450	0.1550	0.1520
No. 12 (0.216)	24	0.1710	0.1810	0.1770
1/4	20	0.1960	0.2070	0.2040
5/16	18	0.2520	0.2650	0.2610
3/8	16	0.3070	0.3210	0.3160
7/16	14	0.3600	0.3760	0.3680
1/2	13	0.4170	0.4340	0.4219
9/16	12	0.4720	0.4900	0.4844
5/8	11	0.5270	0.5460	0.5313
3/4	10	0.6420	0.6630	0.6563
7/8	9	0.7550	0.7780	0.7656
1	8	0.8650	0.8900	0.8750
1 1/8	7	0.9700	0.9980	0.9843
1 1/4	7	1.0950	1.1230	1.1094
1 3/8	6	1.1950	1.2250	1.2205
1 1/2	6	1.3200	1.3500	1.3386
1 3/4	5	1.5330	1.5670	1.5551
2	4 1/2	1.7590	1.7950	1.7812
2 1/4	4 1/2	2.0090	2.0450	2.0312
2 1/2	4	2.2290	2.2670	2.2500
2 3/4	4	2.4790	2.5170	2.5000
3	4	2.7290	2.7670	2.7500

UNF

Unified fine thread
ASME B1.1, Table 2

Nominal Size	P [T.P.I.]	Minor thread dia. of the internal thread (Tol. 2B)		Rec. tap drill size
		D ₁ min.	D ₁ max.	
No. 0 (0.060)	80	0.0465	0.0514	0.0480
No. 1 (0.073)	72	0.0580	0.0634	0.0595
No. 2 (0.086)	64	0.0691	0.0752	0.0730
No. 3 (0.099)	56	0.0797	0.0865	0.0827
No. 4 (0.112)	48	0.0894	0.0968	0.0945
No. 5 (0.125)	44	0.1004	0.1079	0.1063
No. 6 (0.138)	40	0.1110	0.1190	0.1181
No. 8 (0.164)	36	0.1340	0.1420	0.1378
No. 10 (0.190)	32	0.1560	0.1640	0.1614
No. 12 (0.216)	28	0.1770	0.1860	0.1820
1/4	28	0.2110	0.2200	0.2165
5/16	24	0.2670	0.2770	0.2717
3/8	24	0.3300	0.3400	0.3346
7/16	20	0.3830	0.3950	0.3898
1/2	20	0.4460	0.4570	0.4528
9/16	18	0.5020	0.5150	0.5118
5/8	18	0.5650	0.5780	0.5709
3/4	16	0.6820	0.6960	0.6890
7/8	14	0.7980	0.8130	0.8071
1	12	0.9100	0.9280	0.9219
1 1/8	12	1.0350	1.0530	1.0433
1 1/4	12	1.1600	1.1780	1.1719
1 3/8	12	1.2850	1.3030	1.2992
1 1/2	12	1.4100	1.4280	1.4173

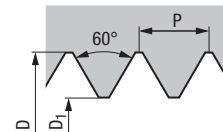
American Standard
Threads

UNEF

Unified extra fine thread
ASME B1.1, Table 2

Nominal Size	P [T.P.I.]	Minor thread dia. of the internal thread (Tol. 2B)		Rec. tap drill size
		D ₁ min.	D ₁ max.	
No. 12 (0.216)	32	0.1820	0.1900	0.1875
1/4	32	0.2160	0.2240	0.2205
5/16	32	0.2790	0.2860	0.2835
3/8	32	0.3410	0.3490	0.3465
7/16	28	0.3990	0.4070	0.4040
1/2	28	0.4610	0.4700	0.4646
9/16	24	0.5170	0.5270	0.5236
5/8	24	0.5800	0.5900	0.5807
3/4	20	0.6960	0.7070	0.6988
7/8	20	0.8210	0.8320	0.8268
1	20	0.9460	0.9570	0.9531
1 1/8	18	1.0650	1.0780	1.0728
1 1/4	18	1.1900	1.2030	1.2008
1 3/8	18	1.3150	1.3280	1.3189
1 1/2	18	1.4400	1.4530	1.4488

UN-8

Unified thread
ASME B1.1, Table 2

Nominal Size	P [T.P.I.]	Minor thread dia. of the internal thread (Tol. 2B)		Rec. tap drill size
		D ₁ min.	D ₁ max.	
1 1/8	8	0.9900	1.0150	1.0000
1 1/4	8	1.1150	1.1400	1.1250
1 3/8	8	1.2400	1.2650	1.2500
1 1/2	8	1.3650	1.3900	1.3750
1 5/8	8	1.4900	1.5150	1.5000
1 3/4	8	1.6150	1.6400	1.6250
1 7/8	8	1.7400	1.7650	1.7500
2	8	1.8650	1.8900	1.8750
2 1/4	8	2.1150	2.1400	2.1250
2 1/2	8	2.3650	2.3900	2.3750
2 3/4	8	2.6150	2.6400	2.6250
3	8	2.8650	2.8900	2.8750
3 1/2	8	3.3650	3.3900	3.3750
4	8	3.8650	3.8900	3.8750
4 1/2	8	4.3650	4.3900	4.3750

Product
FinderV_c

UNC

UNF

UNEF

UN-8

NPT

NPSM/NPSC

NPSF

Rp (BSPP)

G

NPT

NPTF

Rc (BSPT)

STI

SELF-LOCK

Accessories

Tech. Info



- Product Finder
- V_c
- UNC
- UNF
- UNEF
- UN-8
- M
- MF
- NPSM/NPSC
- NPSF
- Rp (BSPP)
- G
- NPT
- NPTF
- Rc (BSPT)
- STI
- SELF-LOCK
- Accessories
- Tech. Info**

1.16 Recommended tap drill sizes for tapping internal threads

ISO Metric Threads

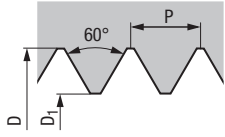

M

ISO Metric coarse thread
DIN 13 and DIN ISO 965-1, ASME B1.13M

Nominal Size	P	Minor thread dia. of the internal thread (Tol. 6H)		Rec. tap drill size	
		D ₁ min. [mm]	D ₁ max. [mm]	[mm]	[inch]
M 2	0.4	1.567	1.679	1.6	0.0630
M 2.5	0.45	2.013	2.138	2.05	0.0807
M 3	0.5	2.459	2.599	2.5	0.0984
M 3.5	0.6	2.850	3.010	2.9	0.1142
M 4	0.7	3.242	3.422	3.3	0.1299
M 4.5	0.75	3.688	3.878	3.7	0.1457
M 5	0.8	4.134	4.334	4.2	0.1654
M 6	1	4.917	5.153	5	0.1969
M 7	1	5.917	6.153	6	0.2362
M 8	1.25	6.647	6.912	6.8	0.2677
M 9	1.25	7.647	7.912	7.8	0.3071
M 10	1.5	8.376	8.676	8.5	0.3346
M 11	1.5	9.376	9.676	9.5	0.3740
M 12	1.75	10.106	10.441	10.2	0.4016
M 14	2	11.835	12.210	12	0.4724
M 16	2	13.835	14.210	14	0.5512
M 18	2.5	15.294	15.744	15.5	0.6102
M 20	2.5	17.294	17.744	17.5	0.6890
M 22	2.5	19.294	19.744	19.5	0.7677
M 24	3	20.752	21.252	21	0.8268
M 27	3	23.752	24.252	24	0.9449
M 30	3.5	26.211	26.771	26.5	1.0433
M 33	3.5	29.211	29.771	29.5	1.1614
M 36	4	31.670	32.270	32	1.2598
M 39	4	34.670	35.270	35	1.3780
M 42	4.5	37.129	37.799	37.5	1.4764
M 45	4.5	40.129	40.799	40.5	1.5945
M 48	5	42.587	43.297	43	1.6929
M 52	5	46.587	47.297	47	1.8504

MF

ISO Metric fine thread
DIN 13 and DIN ISO 965-1, ASME B1.13M

Nominal Size	P	Minor thread dia. of the internal thread (Tol. 6H)		Rec. tap drill size	
		D ₁ min. [mm]	D ₁ max. [mm]	[mm]	[inch]
M 4 x 0.5		3.459	3.599	3.5	0.1378
M 5 x 0.5		4.459	4.599	4.5	0.1772
M 6 x 0.75		5.188	5.378	5.2	0.2047
M 8 x 0.75		7.188	7.378	7.2	0.2835
M 8 x 1		6.917	7.153	7	0.2756
M 10 x 1		8.917	9.153	9	0.3543
M 10 x 1.25		8.647	8.912	8.8	0.3465
M 12 x 1.5		10.376	10.676	10.5	0.4134
M 14 x 1.5		12.376	12.676	12.5	0.4921
M 16 x 1.5		14.376	14.676	14.5	0.5709
M 18 x 1.5		16.376	16.676	16.5	0.6496
M 20 x 1.5		18.376	18.676	18.5	0.7283
M 22 x 2		19.835	20.210	20	0.7874
M 24 x 2		21.835	22.210	22	0.8661
M 27 x 2		24.835	25.210	25	0.9843
M 30 x 2		27.835	28.210	28	1.1024
M 36 x 3		32.752	33.252	33	1.2992
M 42 x 3		38.752	39.252	39	1.5354
M 48 x 3		44.752	45.252	45	1.7717
M 52 x 4		47.670	48.270	48	1.8898

Tap drill sizes of Metric fine threads which are not listed can be found by considering the diameter difference.

1.16 Recommended tap drill sizes for tapping internal threads

NPSM

American Standard straight pipe thread
ANSI/ASME B1.20.1

For mechanical joints (previously NPS)

Nominal Size	P [T.P.I.]	Minor thread dia. of the internal thread		Rec. tap drill size	
		D ₁ min.	D ₁ max.	[mm]	[inch]
1/8	27	0.358	0.364	9.1	0.3583
1/4	18	0.468	0.481	12	0.4724
3/8	18	0.603	0.612	15.5	0.6102
1/2	14	0.747	0.759	19	0.7480
3/4	14	0.958	0.970	24.5	0.9646
1	11 1/2	1.201	1.211	30.5	1.2008

NPSF

NPSF

American Standard straight pipe thread
ANSI B1.20.3, Table B1

Dryseal internal straight pipe thread for fuel, combined with external tapered pipe thread NPTF or PTF-SAE-SHORT; Gage with tapered gages

Nominal Size	P [T.P.I.]	Minor thread dia. of the internal thread		Rec. tap drill size	
		D ₁ min.	[mm]	[inch]	
1/16	27	0.2482	6.25	0.246	
1/8	27	0.3406	8.6	0.339	
1/4	18	0.4422	11.15	0.438	
3/8	18	0.5776	14.7	0.578	
1/2	14	0.7133	17.85	0.703	
3/4	14	0.9238	23.4	0.922	
1	11 1/2	1.1600	29.35	1.156	

Straight Pipe Threads

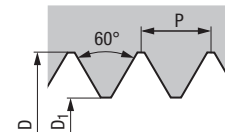

NPSM

American Standard internal straight thread
ANSI/ASME B1.20.1, Table A1

In pipe coupling

Nominal Size	P [T.P.I.]	Minor thread dia. of the internal thread		Rec. tap drill size	
		D ₁ min.	[mm]	[inch]	
1/8	27	0.340	8.75	0.344	
1/4	18	0.442	11.1	0.438	
3/8	18	0.577	14.7	0.578	
1/2	14	0.715	18.25	0.719	
3/4	14	0.925	23.4	0.922	
1	11 1/2	1.161	29.35	1.156	

Rp (BSPP)

Cylindrical Whitworth pipe thread
DIN EN 10226-1 and ISO 7-1

Where pressure-tight joints are made on the threads

Nominal Size	P [T.P.I.]	Minor thread dia. of the internal thread		Rec. tap drill size	
		D ₁ min. [mm]	D ₁ max. [mm]	[mm]	[inch]
Rp 1/16	28	6.490	6.632	6.55	0.2579
Rp 1/8	28	8.495	8.637	8.6	0.3386
Rp 1/4	19	11.341	11.549	11.5	0.4528
Rp 3/8	19	14.846	15.054	15	0.5906
Rp 1/2	14	18.489	18.773	18.5	0.7283
Rp 3/4	14	23.975	24.259	24	0.9449
Rp 1	11	30.111	30.471	30.25	1.1909

G

Whitworth pipe thread
DIN EN ISO 228

Nominal Size	P [T.P.I.]	Minor thread dia. of the internal thread		Rec. tap drill size	
		D ₁ min. [mm]	D ₁ max. [mm]	[mm]	[inch]
G 1/16	28	6.561	6.843	6.8	0.2677
G 1/8	28	8.566	8.848	8.8	0.3465
G 1/4	19	11.445	11.890	11.8	0.4646
G 3/8	19	14.950	15.395	15.25	0.6004
G 1/2	14	18.631	19.172	19	0.7480
G 5/8	14	20.587	21.128	21	0.8268
G 3/4	14	24.117	24.658	24.5	0.9646
G 7/8	14	27.877	28.418	28.25	1.1122
G 1	11	30.291	30.931	30.75	1.2106
G 1 1/8	11	34.939	35.579	35.5	1.3976
G 1 1/4	11	38.952	39.592	39.5	1.5551
G 1 3/8	11	41.365	42.005	41.75	1.6437
G 1 1/2	11	44.845	45.485	45.25	1.7815
G 1 5/8	11	49.030	49.670	49.5	1.9488
G 1 3/4	11	50.788	51.428	51	2.0079
G 2	11	56.656	57.296	57	2.2441
G 2 1/4	11	62.752	63.392	63.3	2.4921
G 2 1/2	11	72.226	72.866	72.8	2.8661
G 2 3/4	11	78.576	79.216	79.1	3.1142
G 3	11	84.926	85.566	85.5	3.3661

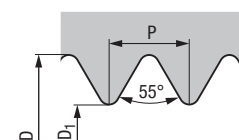

Product Finder

Vc

UNC

UNF

UNEF

UN-8

MF

NPSM/NPSC

NPSF

Rp (BSPP)

G

NPT

NPTF

Rc (BSPT)

STI

SELF-LOCK

Accessories

Tech. Info



- Product Finder
- V_c
- UNC
- UNF
- UNEF
- UN-8
- M
- MF
- NPSM/NPSC
- NPSF
- Rp (BSPP)
- G
- NPT
- NPTF
- Rc (BSPT)
- STI
- SELF-LOCK
- Accessories
- Tech. Info

1.16 Recommended tap drill sizes for tapping internal threads

Taper Pipe Threads

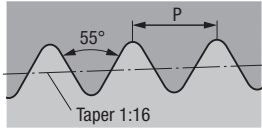
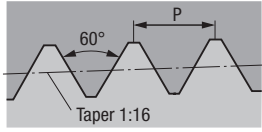

NPT

American tapered pipe thread,
ANSI/ASME B1.20.1

For threads **with dryseal material**,
taper 1:16

Nominal Size	P [T.P.I.]	D ₁	D ₂	D ₃ (+0.002)	t ₁
1/16	27	0.2421	0.2343	0.2516	0.4646
1/8	27	0.3346	0.3268	0.3441	0.4685
1/4	18	0.4331	0.4232	0.4472	0.6850
3/8	18	0.5669	0.5571	0.5827	0.6969
1/2	14	0.7008	0.6870	0.7213	0.9094
3/4	14	0.9114	0.8976	0.9319	0.9291
1	11 1/2	1.1437	1.1280	1.1689	1.1181
1 1/4	11 1/2	1.4882	1.4705	1.5138	1.1378
1 1/2	11 1/2	1.7264	1.7106	1.7528	1.1378
2	11 1/2	2.1988	2.1831	2.2268	1.1535

NPTF

American tapered pipe thread,
ANSI B1.20.3

For threads **without dryseal material**,
taper 1:16

Nominal Size	P [T.P.I.]	D ₁	D ₂	D ₃ (+0.002)	t ₁
1/16	27	0.2402	0.2343	0.2524	0.4646
1/8	27	0.3327	0.3268	0.3449	0.4685
1/4	18	0.4291	0.4232	0.4488	0.6850
3/8	18	0.5630	0.5571	0.5843	0.6969
1/2	14	0.6929	0.6870	0.7217	0.9094
3/4	14	0.9055	0.8976	0.9323	0.9291
1	11 1/2	1.1319	1.1280	1.1701	1.1181
1 1/4	11 1/2	1.4764	1.4705	1.5150	1.1378
1 1/2	11 1/2	1.7224	1.7106	1.7539	1.1378
2	11 1/2	2.1949	2.1831	2.2280	1.1535

Rc (BSPT)

Tapered Whitworth pipe thread
DIN EN 10226-2 and ISO 7-1

Where pressure-tight joints are made on the threads,
taper 1:16

Nominal Size	P [T.P.I.]	D ₁ [mm]	D ₂ [mm]	D ₃ (JS11) [mm]	t ₁ [mm]
Rc 1/16	28	6.15	6.1	6.56	11.1
Rc 1/8	28	8.15	8.1	8.57	11.1
Rc 1/4	19	10.85	10.75	11.45	16.3
Rc 3/8	19	14.3	14.25	14.95	16.7
Rc 1/2	14	17.8	17.7	18.63	22.3
Rc 3/4	14	23.2	23.1	24.12	23.6
Rc 1	11	29.2	29.1	30.29	28.3

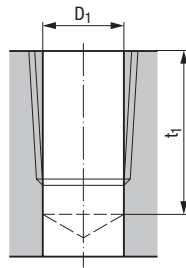

Drill cylindrically without using a reamer

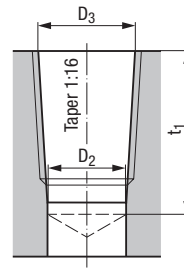

Drill cylindrically and prepare tapered hole with reamer

The minimum drilling depth t₁ includes the reach of screw by hand L₁ and the effective depth L₃ to ANSI/ASME B1.20.1 as well as the chamfer of the tap. Additional drilling-down has to be determined by the user according to the construction of the workpiece.

For series production it is recommended that the minor thread dia. be made as per B. Special taps are required for blind holes where the minimum depths t₁ as listed in the above table cannot be met. In this case please supply a sketch with blind hole dimensions along with the order.

1.16 Recommended tap drill sizes for tapping internal threads

STI-UNC

Unified coarse thread
ASME B18.29.1

For wire thread inserts

Nominal Size	P [T.P.I.]	Major thread dia. of the internal thread (Tol. 2B)		Minor thread dia. of the internal thread (Tol. 2B)		Rec. tap drill size
		D _{STI} min.	D _{1STI} min.	D _{1STI} max.		
STI-No. 2	56	0.1092	0.0899	0.0961	0.0906	
STI-No. 3	48	0.1261	0.1036	0.1104	0.1063	
STI-No. 4	40	0.1445	0.1175	0.1252	0.1220	
STI-No. 5	40	0.1575	0.1305	0.1373	0.1339	
STI-No. 6	32	0.1786	0.1448	0.1527	0.1496	
STI-No. 8	32	0.2046	0.1708	0.1781	0.1732	
STI-No. 10	24	0.2441	0.1990	0.2080	0.2047	
STI-No. 12	24	0.2701	0.2250	0.2340	0.2283	
STI- 1/4	20	0.3150	0.2608	0.2704	0.2638	
STI- 5/16	18	0.3847	0.3245	0.3342	0.3307	
STI- 3/8	16	0.4562	0.3885	0.3987	0.3937	
STI- 7/16	14	0.5303	0.4530	0.4639	0.4567	
STI- 1/2	13	0.5999	0.5166	0.5273	0.5236	
STI- 9/16	12	0.6708	0.5806	0.5918	0.5866	
STI- 5/8	11	0.7431	0.6447	0.6564	0.6496	
STI- 3/4	10	0.8799	0.7716	0.7838	0.7776	
STI- 7/8	9	1.0193	0.8990	0.9119	0.9055	
STI- 1	8	1.1624	1.0271	1.0421	1.0335	
STI- 1 1/8	7	1.3106	1.1559	1.1730	1.1614	
STI- 1 1/4	7	1.4356	1.2809	1.2980	1.2894	
STI- 1 3/8	6	1.5915	1.4110	1.4310	1.4173	
STI- 1 1/2	6	1.7165	1.5360	1.5560	1.5453	

STI-UNF

Unified fine thread
ASME B18.29.1

For wire thread inserts

Nominal Size	P [T.P.I.]	Major thread dia. of the internal thread (Tol. 2B)		Minor thread dia. of the internal thread (Tol. 2B)		Rec. tap drill size
		D _{STI} min.	D _{1STI} min.	D _{1STI} max.		
STI-No. 2	64	0.1063	0.0894	0.0947	0.0906	
STI-No. 3	56	0.1222	0.1029	0.1086	0.1063	
STI-No. 4	48	0.1391	0.1166	0.1229	0.1181	
STI-No. 6	40	0.1705	0.1435	0.1503	0.1457	
STI-No. 8	36	0.2001	0.1701	0.1771	0.1732	
STI-No. 10	32	0.2306	0.1968	0.2041	0.2008	
STI- 1/4	28	0.2964	0.2577	0.2646	0.2598	
STI- 5/16	24	0.3666	0.3215	0.3288	0.3248	
STI- 3/8	24	0.4291	0.3840	0.3910	0.3858	
STI- 7/16	20	0.5025	0.4483	0.4561	0.4528	
STI- 1/2	20	0.5650	0.5108	0.5186	0.5157	
STI- 9/16	18	0.6347	0.5745	0.5826	0.5787	
STI- 5/8	18	0.6972	0.6370	0.6451	0.6398	
STI- 3/4	16	0.8312	0.7635	0.7720	0.7677	
STI- 7/8	14	0.9678	0.8905	0.8994	0.8957	
STI- 1	12	1.1083	1.0181	1.0281	1.0236	
STI- 1 1/8	12	1.2333	1.1431	1.1531	1.1516	
STI- 1 1/4	12	1.3583	1.2681	1.2781	1.2795	
STI- 1 3/8	12	1.4833	1.3931	1.4031	1.3976	
STI- 1 1/2	12	1.6083	1.5181	1.5281	1.5256	

Screw Thread Insert Threads (STI)

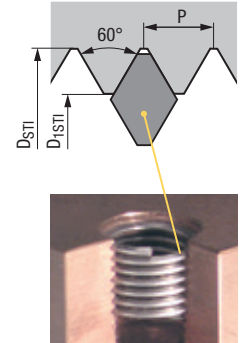

STI-M

ISO Metric coarse thread
DIN 8140-2

For wire thread inserts

Nominal Size	Major thread dia. of the internal thread (Tol. 6H mod.)		Minor thread dia. of the internal thread (Tol. 6H mod.)		Rec. tap drill size	
	P [mm]	D _{STI} min. [mm]	D _{1STI} min. [mm]	D _{1STI} max. [mm]	[mm]	[inch]
STI-M 2	0.4	2.520	2.087	2.177	2.1	0.0827
STI-M 2.5	0.45	3.084	2.597	2.697	2.65	0.1043
STI-M 3	0.5	3.650	3.108	3.220	3.15	0.1240
STI-M 4	0.7	4.910	4.152	4.292	4.2	0.1654
STI-M 5	0.8	6.040	5.174	5.334	5.25	0.2067
STI-M 6	1	7.300	6.217	6.407	6.3	0.2480
STI-M 8	1.25	9.624	8.271	8.483	8.4	0.3307
STI-M 10	1.5	11.948	10.324	10.560	10.5	0.4134
STI-M 12	1.75	14.274	12.379	12.644	12.5	0.4921
STI-M 14	2	16.598	14.433	14.733	14.5	0.5709
STI-M 16	2	18.598	16.433	16.733	16.5	0.6496
STI-M 18	2.5	21.248	18.541	18.896	18.75	0.7382
STI-M 20	2.5	23.248	20.541	20.896	20.75	0.8169
STI-M 22	2.5	25.248	22.541	22.896	22.75	0.8957
STI-M 24	3	27.897	24.649	25.049	24.75	0.9744
STI-M 27	3	30.897	27.649	28.049	27.75	1.0925
STI-M 30	3.5	34.546	30.757	31.207	31	1.2205

Product Finder

V_c

UNC

UNF

UNEF

UN-8

MF

NPSM/NPSC

NPSF

Rp (BSP)

G

NPT

NPTF

Rc (BSP)

STI

SELF-LOCK

Accessories

Tech. Info



- Product Finder
- V_c
- UNC
- UNF
- UNEF
- UN-8
- M
- MF
- NPSM/NPSC
- NPSF
- Rp (BSPP)
- G
- NPT
- NPTF
- Rc (BSPT)
- STI
- SELF-LOCK
- Accessories

1.16 Recommended tap drill sizes for tapping internal threads

Self-Locking Threads

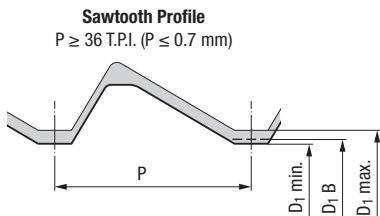

With the Sawtooth profile the mentioned drill sizes have to be considered. If the hole diameter becomes too large, safe functioning is jeopardized.

Self-locking taps are produced with an accurate profile. The Metric LK-female thread mates with a Metric ISO bolt of grade "6g". Thread sizes of male fasteners are according to DIN 13, part 19.20.

LK-UNC

Unified SELF-LOCK coarse thread
 EMUGE standard

Nominal Size	P [T.P.I.]	LK-Core hole dia.			D ₁ B Drill dia. (Line 1)
		D ₁ min.	D ₁ max.		
D			Line 1	Line 2	
LK-No. 6	32	0.1119	0.1219	0.1217	0.1142
LK-No. 8	32	0.1378	0.1468	0.1476	0.1417
LK-No. 10	24	0.1544	0.1654	0.1675	0.1575
LK-No. 12	24	0.1804	0.1904	0.1935	0.1850
LK- 1/4	20	0.2069	0.2179	0.2226	0.2087
LK- 5/16	18	0.2644	0.2774	0.2818	0.2677
LK- 3/8	16	0.3204	0.3344	0.3400	0.3268
LK- 7/16	14	0.3748	0.3908	0.3972	0.3819
LK- 1/2	13	0.4323	0.4493	0.4564	0.4375
LK- 9/16	12	0.4887	0.5067	0.5148	0.5000
LK- 5/8	11	0.5443	0.5633	0.5728	0.5512
LK- 3/4	10	0.6609	0.6819	0.6922	0.6693

LK-M

Metric SELF-LOCK coarse thread
 EMUGE standard

Nominal Size	P [mm]	LK-Core hole dia.			D ₁ B Drill dia. (Line 1)	
		D ₁ min.	D ₁ max.		[mm]	[inch]
D		[mm]	Line 1 [mm]	Line 2 [mm]		
LK-M 3	0.5	2.673	2.745	—	2.7	0.1063
LK-M 4	0.7	3.549	3.639	—	3.55	0.1398
LK-M 5	0.8	4.324	4.524	4.574	4.4	0.1732
LK-M 6	1	5.152	5.388	5.465	5.2	0.2047
LK-M 8	1.25	6.931	7.196	7.322	7	0.2756
LK-M 10	1.5	8.700	9.000	9.170	8.8	0.3465
LK-M 12	1.75	10.477	10.812	11.024	10.7	0.4213
LK-M 14	2	12.237	12.612	12.863	12.5	0.4921
LK-M 16	2	14.237	14.612	14.863	14.5	0.5709
LK-M 18	2.5	15.787	16.237	16.569	16	0.6299
LK-M 20	2.5	17.787	18.237	18.569	18	0.7087
LK-M 24	3	21.320	21.820	22.259	21.5	0.8465

It is possible to use Line 2 when machining heavy materials.

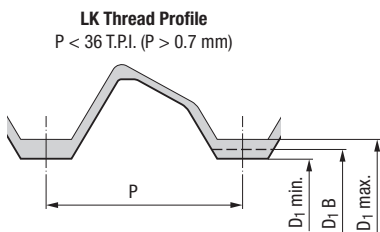

For the specification of the maximum core hole minor diameter, as a general rule, use Line 1. For special applications, machining heavy materials for example, depth of thread is 2 x diameter, or if higher tool life is required, it is possible to use Line 2. The maximum LK-minor core hole diameter listed in Line 2 cannot be exceeded as the performance of the EMUGE SELF-LOCK system would be negatively affected. Minimum LK-minor diameters should not go below those listed.

1.17 Decimal equivalents for tap drill selection

Inch-Wire [mm]	Decimal Inch	Inch-Wire [mm]	Decimal Inch	Inch-Wire [mm]	Decimal Inch	Inch-Wire [mm]	Decimal Inch	Inch-Wire [mm]	Decimal Inch
0.1 mm	0.0039	2.1 mm	0.0827	15	0.1800	M	0.2950	33/64	0.5156
0.2 mm	0.0079	44	0.0860	4.6 mm	0.1811	7.5 mm	0.2953	17/32	0.5313
0.3 mm	0.0118	2.2 mm	0.0866	14	0.1820	19/64	0.2969	13.5 mm	0.5315
80	0.0135	43	0.0890	13 / 4.7 mm	0.1850	7.6 mm	0.2992	35/64	0.5469
79	0.0145	2.3 mm	0.0906	3/16	0.1875	N	0.3020	14 mm	0.5512
1/64	0.0156	42	0.0935	12 / 4.8 mm	0.1890	7.7 mm	0.3031	9/16	0.5625
0.4 mm	0.0157	3/32	0.0938	11	0.1910	7.8 mm	0.3071	14.5 mm	0.5709
78	0.0160	2.4 mm	0.0945	4.9 mm	0.1929	7.9 mm	0.3110	37/64	0.5781
77	0.0180	41	0.0960	10	0.1935	5/16	0.3125	15 mm	0.5906
0.5 mm	0.0197	40	0.0980	9	0.1960	8 mm	0.3150	19/32	0.5938
76	0.0200	2.5 mm	0.0984	5 mm	0.1969	O	0.3160	39/64	0.6094
75	0.0210	39	0.0995	8	0.1990	8.1 mm	0.3189	15.5 mm	0.6102
74	0.0225	38	0.1015	5.1 mm	0.2008	8.2 mm	0.3228	5/8	0.6250
0.6 mm	0.0236	2.6 mm	0.1024	7	0.2010	P	0.3230	16 mm	0.6299
73	0.0240	37	0.1040	13/64	0.2031	8.3 mm	0.3268	41/64	0.6406
72	0.0250	2.7 mm	0.1063	6	0.2040	21/64	0.3281	16.5 mm	0.6496
71	0.0260	36	0.1065	5.2 mm	0.2047	8.4 mm	0.3307	21/32	0.6563
0.7 mm	0.0276	7/64	0.1094	5	0.2055	Q	0.3320	17 mm	0.6693
70	0.0280	35	0.1100	5.3 mm	0.2087	8.5 mm	0.3346	43/64	0.6719
69	0.0292	2.8 mm	0.1102	4	0.2090	8.6 mm	0.3386	11/16	0.6875
68	0.0310	34	0.1110	5.4 mm	0.2126	R	0.3390	17.5 mm	0.6890
1/32	0.0312	33	0.1130	3	0.2130	8.7 mm	0.3425	45/64	0.7031
0.8 mm	0.0315	2.9 mm	0.1142	5.5 mm	0.2165	11/32	0.3438	18 mm	0.7087
67	0.0320	32	0.1160	7/32	0.2188	8.8 mm	0.3465	23/32	0.7188
66	0.0330	3 mm	0.1181	5.6 mm	0.2205	S	0.3480	18.5 mm	0.7283
65	0.0350	31	0.1200	2	0.2210	8.9 mm	0.3504	47/64	0.7344
0.9 mm	0.0354	3.1 mm	0.1220	5.7 mm	0.2244	9 mm	0.3543	19 mm	0.7480
64	0.0360	1/8	0.1250	1	0.2280	T	0.3580	3/4	0.7500
63	0.0370	3.2 mm	0.1260	5.8 mm	0.2283	9.1 mm	0.3583	49/64	0.7656
62	0.0380	30	0.1285	5.9 mm	0.2323	23/64	0.3594	19.5 mm	0.7677
61	0.0390	3.3 mm	0.1299	A	0.2340	9.2 mm	0.3622	25/32	0.7813
1.0 mm	0.0394	3.4 mm	0.1339	15/64	0.2344	9.3 mm	0.3661	20 mm	0.7874
60	0.0400	29	0.1360	6 mm	0.2362	U	0.3680	51/64	0.7969
59	0.0410	3.5 mm	0.1378	B	0.2380	9.4 mm	0.3701	20.5 mm	0.8071
58	0.0420	28	0.1405	6.1 mm	0.2402	9.5 mm	0.3740	13/16	0.8125
57	0.0430	9/64	0.1406	C	0.2420	3/8	0.3750	21 mm	0.8268
56	0.0465	3.6 mm	0.1417	6.2 mm	0.2441	V	0.3770	53/64	0.8281
3/64	0.0469	27	0.1440	D	0.2460	9.6 mm	0.3780	27/32	0.8438
1.2 mm	0.0472	3.7 mm	0.1457	6.3 mm	0.2480	9.7 mm	0.3819	21.5 mm	0.8465
1.3 mm	0.0512	26	0.1470	1/4 / E	0.2500	9.8 mm	0.3858	55/64	0.8594
55	0.0520	25	0.1495	6.4 mm	0.2520	W	0.3860	22 mm	0.8661
54	0.0550	3.8 mm	0.1496	6.5 mm	0.2559	9.9 mm	0.3898	7/8	0.8750
1.4 mm	0.0551	24	0.1520	F	0.2570	25/64	0.3906	22.5 mm	0.8858
1.5 mm	0.0591	3.9 mm	0.1535	6.6 mm	0.2598	10 mm	0.3937	57/64	0.8906
53	0.0595	23	0.1540	G	0.2610	X	0.3970	23 mm	0.9055
1/16	0.0625	5/32	0.1563	6.7 mm	0.2638	Y	0.4040	29/32	0.9063
1.6 mm	0.0630	22	0.1570	17/64	0.2656	13/32	0.4063	59/64	0.9219
52	0.0635	4 mm	0.1575	H	0.2660	Z	0.4130	23.5 mm	0.9252
1.7 mm	0.0669	21	0.1590	6.8 mm	0.2677	10.5 mm	0.4134	15/16	0.9375
51	0.0670	20	0.1610	6.9 mm	0.2717	27/64	0.4219	24 mm	0.9449
50	0.0700	4.1 mm	0.1614	I	0.2720	11 mm	0.4331	61/64	0.9531
1.8 mm	0.0709	4.2 mm	0.1654	7 mm	0.2756	7/16	0.4375	24.5 mm	0.9646
49	0.0730	19	0.1660	J	0.2770	11.5 mm	0.4528	31/32	0.9688
1.9 mm	0.0748	4.3 mm	0.1693	7.1 mm	0.2795	29/64	0.4531	25 mm	0.9843
48	0.0760	18	0.1695	K	0.2810	15/32	0.4688	63/64	0.9844
5/64	0.0781	11/64	0.1719	9/32	0.2813	12 mm	0.4724	1	1.0000
47	0.0785	17	0.1730	7.2 mm	0.2835	31/64	0.4844		
2 mm	0.0787	4.4 mm	0.1732	7.3 mm	0.2874	12.5 mm	0.4921		
46	0.0810	16	0.1770	L	0.2900	1/2	0.5000		
45	0.0820	4.5 mm	0.1772	7.4 mm	0.2913	13 mm	0.5118		

The tap drill sizes shown are reference values and may have to be altered to meet specific tapping requirements. EMUGE shall have no liability or responsibility of any kind resulting from the selection of a tap drill size from this chart. Values printed are correct at the time of printing and subject to change without notice.



- Product Finder
- V_c
- UNC
- UNF
- UNEF
- UN-8
- M
- MF
- NPSM/NPSC
- NPSF
- Rp (BSPP)
- G
- NPT
- NPTF
- Rc (BSPT)
- STI
- SELF-LOCK
- Accessories
- Tech. Info**

1.18 Conversion table SFM to RPM for taps

Tap Sizes			Surface Feet per Minute																	
			5'	10'	15'	20'	25'	30'	40'	50'	60'	70'	80'	90'	100'	110'	120'	130'	140'	150'
UNC UNF	NPT NPTF		Revolutions per Minute																	
No. 0			318	637	955	1273	1592	1910	2546	3183	3820	4456	5093	5729	6366	7003	7639	8276	8913	9549
No. 1			273	546	819	1046	1308	1570	2093	2617	3140	3663	4186	4710	5233	5756	6279	6805	7326	7849
No. 2			212	424	637	888	1110	1333	1777	2221	2665	3109	3554	3999	4442	4886	5330	5774	6218	6662
No. 3			191	382	573	772	964	1157	1543	1929	2315	2701	3086	3472	3858	4244	4629	5015	5401	5787
No. 4			174	347	521	682	853	1023	1364	1705	2046	2387	2728	3069	3411	3751	4092	4434	4775	5116
No. 5			147	294	441	611	764	917	1222	1528	1833	2139	2445	2750	3056	3361	3667	3973	4278	4584
No. 6			136	273	409	553	691	829	1106	1382	1659	1935	2212	2488	2766	3042	3318	3595	3871	4148
No. 8			119	239	358	466	583	699	932	1165	1398	1631	1864	2097	2330	2563	2796	3029	3262	3495
No. 10			101	201	302	402	502	603	804	1005	1205	1406	1607	1808	2009	2210	2411	2612	2813	3014
No. 12			87	174	260	354	442	531	707	884	1061	1238	1415	1592	1769	1945	2122	2300	2476	2653
1/4			76	153	229	306	382	458	611	764	917	1070	1222	1375	1528	1681	1833	1986	2139	2292
5/16			62	123	185	245	306	367	489	611	733	856	978	1100	1222	1345	1467	1589	1711	1833
3/8			50	101	151	204	255	305	407	509	611	713	815	917	1019	1120	1222	1324	1426	1528
7/16	1/8		43	87	130	175	219	262	349	437	524	611	698	786	873	960	1048	1135	1222	1310
1/2			38	76	115	153	191	229	305	382	458	535	611	688	764	840	917	993	1070	1146
9/16	1/4		34	68	102	137	172	206	274	342	410	478	547	616	683	752	820	888	952	1020
5/8			32	64	96	122	153	183	244	306	367	428	489	550	611	672	733	794	856	917
11/16	3/8		28	55	83	111	138	167	222	278	333	389	444	500	556	611	667	722	778	833
3/4			25	51	76	102	128	153	203	255	305	357	407	458	509	560	611	662	713	764
7/8	1/2		22	43	65	87	109	131	175	218	262	306	350	392	437	480	524	568	611	655
1			19	38	57	76	96	115	153	191	230	268	305	344	382	420	458	497	535	573
1 1/8	3/4		17	34	51	68	84	102	136	170	204	238	272	306	340	373	407	441	475	509
1 1/4			15	31	46	61	76	92	122	153	183	214	244	275	305	336	367	397	428	458
1 3/8	1		14	28	42	56	69	83	111	139	167	194	222	250	278	306	333	361	389	417
1 1/2			13	25	38	51	63	76	102	127	153	178	204	229	255	280	305	331	356	382
1 5/8			12	23	35	47	59	71	94	118	141	165	188	212	235	259	282	306	329	353
1 3/4			11	22	33	44	55	65	87	109	131	153	175	196	218	240	262	284	306	327
1 7/8			10	20	30	41	51	61	81	102	122	143	163	183	204	224	244	265	285	306
2			9	19	29	38	48	57	76	96	115	134	153	172	191	210	229	248	267	287

Metric Taps																				
M 1	490	979	1469	1959	2449	2938	3918	4897	5877	6856	7836	8815	9795	10774	11754	12733	13713	14692		
M 2	242	484	725	967	1209	1451	1934	2418	2901	3385	3868	4352	4835	5319	5803	6286	6770	7253		
M 3	162	324	486	647	809	971	1295	1619	1942	2266	2590	2914	3237	3561	3885	4208	4532	4856		
M 3.5	138	277	415	554	692	830	1107	1384	1661	1938	2214	2491	2768	3045	3322	3599	3875	4152		
M 4	122	243	365	487	608	730	973	1217	1460	1703	1946	2190	2433	2676	2920	3163	3406	3650		
M 5	97	194	291	388	485	582	776	970	1163	1357	1551	1745	1939	2133	2327	2521	2715	2909		
M 6	81	162	243	324	405	486	647	809	971	1133	1295	1457	1619	1781	1942	2104	2266	2428		
M 7	69	138	208	277	346	415	554	692	830	969	1107	1246	1384	1522	1661	1799	1938	2076		
M 8	61	121	182	243	303	364	485	606	728	849	970	1091	1213	1334	1455	1577	1698	1819		
M 10	48	97	145	194	242	291	388	485	582	679	776	873	970	1067	1163	1260	1357	1454		
M 12	40	81	121	162	202	243	324	405	486	567	647	728	809	890	971	1052	1133	1214		
M 14	35	69	104	139	173	208	277	347	416	485	555	624	693	763	832	901	971	1040		
M 16	30	61	91	121	152	182	243	303	364	424	485	546	606	667	728	788	849	910		
M 18	27	54	81	108	135	162	216	269	323	377	431	485	539	593	647	700	754	808		
M 20	24	49	73	97	121	146	194	243	291	340	388	437	485	534	582	631	680	728		
M 22	22	44	66	88	110	132	176	221	265	309	353	397	441	485	529	573	618	662		
M 24	20	40	61	81	101	121	162	202	243	283	323	364	404	445	485	526	566	606		
M 27	18	36	54	72	90	108	144	180	216	252	287	323	359	395	431	467	503	539		
M 30	16	32	49	65	81	97	129	162	194	226	259	291	323	356	388	420	453	485		

For tap sizes not listed, please contact an EMUGE Technical Representative at 800-323-3013.

1.19 Troubleshooting guide for tapping

**Problem: Tapping oversized threads
(no-go gage too loose)**

Possible Cause	Possible Remedy
<ul style="list-style-type: none"> Improper tap for material and thread application. 	<ul style="list-style-type: none"> Use a suitable tap for the hole style and material being tapped. Reference the EMUGE Tap Finder for proper selection.
<ul style="list-style-type: none"> Cutting speed too high. 	<ul style="list-style-type: none"> Reduce cutting speed. Improve coolant/lubrication.
<ul style="list-style-type: none"> Cold welding on the flanks of the tap (loading). 	<ul style="list-style-type: none"> Use a new tool. Use surface treated taps. Improve coolant/lubrication. Grind away chipped and damaged teeth.
<ul style="list-style-type: none"> Chip packing in flutes. 	<ul style="list-style-type: none"> Use tap with different flute geometry/angle. Possibly use set of taps.
<ul style="list-style-type: none"> Grinding burr. 	<ul style="list-style-type: none"> Remove burr with soft wire or fiber brush.
<ul style="list-style-type: none"> Incorrect fixturing or positioning of part. 	<ul style="list-style-type: none"> Use tap holders with axial and parallel floating. Check clamping of part for correct alignment.
<ul style="list-style-type: none"> Inconsistent feed of tap. 	<ul style="list-style-type: none"> Tap with controlled feed. Check CNC programs. Check lead screw for backlash. Use compensating tension/compression tap holder.

**Problem: Tapping oversized threads
(no-go gage loose)**

Possible Cause	Possible Remedy
<ul style="list-style-type: none"> Tap selected too large for class of thread fit required. 	<ul style="list-style-type: none"> Review markings on tap and determine if it is suitable for the class of fit required. If in doubt, contact an EMUGE Representative.
<ul style="list-style-type: none"> Improper reconditioning of tap. 	<ul style="list-style-type: none"> Reconditioning of tap requires that all ground surfaces maintain the original geometry put on by the manufacturer. Contact an EMUGE Representative for instructive information.

**Problem: Tapping bellmouthed hole
(first few threads gage oversize)**

Possible Cause	Possible Remedy
<ul style="list-style-type: none"> Wrong initial starting pressure. 	<ul style="list-style-type: none"> Work with controlled tap feed.
<ul style="list-style-type: none"> Axially hard working spindle. 	<ul style="list-style-type: none"> Use a tap holder with length compensation.
<ul style="list-style-type: none"> Incorrect fixturing or positioning of part. 	<ul style="list-style-type: none"> Use a tap holder with axial and parallel floating. Check clamping of part for correct alignment.

EMUGE Taps are very free cutting and will easily cut oversize threads if overfed or pushed. For the best results, we recommend the use of an EMUGE Quick-Change Tap Holder with built-in tension, compression and overload clutch features. Always utilize your holder's tension feature by programming spindle feed to 95-98% of the calculated feed rate.

Call an EMUGE Representative at 800-323-3013 if you need assistance.

Problem: Torn and rough threads

Possible Cause	Possible Remedy
<ul style="list-style-type: none"> Improper selection of tap for material and thread application. 	<ul style="list-style-type: none"> Use a suitable tap for the hole style and material being tapped. Reference the EMUGE Tap Finder for proper selection.
<ul style="list-style-type: none"> Cutting speed too fast or slow. 	<ul style="list-style-type: none"> Select proper cutting speed. Improve coolant selection to assist the effects of tap speed.
<ul style="list-style-type: none"> Cold welding on the flanks of the tap (loading). 	<ul style="list-style-type: none"> Use a new tool. Use surface treated taps. Improve coolant/lubrication. Find away chipped and damaged teeth.
<ul style="list-style-type: none"> Chips packing in flutes. 	<ul style="list-style-type: none"> Use tap with different flute geometry/angle. Use set of taps.
<ul style="list-style-type: none"> Grinding burr. 	<ul style="list-style-type: none"> Remove burr with soft wire or brush.
<ul style="list-style-type: none"> Tap drill too small. 	<ul style="list-style-type: none"> Use correct size drill. Reference recommended sizes listed in EMUGE catalog. Note that cutting and roll form taps use different size tap drills for the same size thread. If in doubt, contact an EMUGE Representative.
<ul style="list-style-type: none"> Insufficient coolant/ lubrication. 	<ul style="list-style-type: none"> Selection of suitable coolant/lubrication for material being tapped. Use adequate amounts of coolant/lubrication. Use a set of taps.
<ul style="list-style-type: none"> Tool overloading due to coarse pitch, hard materials or short chamfers. 	<ul style="list-style-type: none"> Use a set of taps.

**Problem: Tapping undersized threads
(go gage won't enter/binds up part way into hole)**

Possible Cause	Possible Remedy
<ul style="list-style-type: none"> Tap selected too small to do multiple regrinds. 	<ul style="list-style-type: none"> Limit the number of regrinds a tap has. Use a new tap.
<ul style="list-style-type: none"> Area of wear not removed when tap was resharpener. 	<ul style="list-style-type: none"> Grind tap again. Use a new tap.
<ul style="list-style-type: none"> Improper tap for material and thread application. 	<ul style="list-style-type: none"> Use suitable tap for the hole style and material being tapped. Reference the EMUGE Tap Finder for proper selection.
<ul style="list-style-type: none"> Go gage binds up part way into hole. 	<ul style="list-style-type: none"> Tap is dull – recondition or replace tap. Avoid too much axial force during tapping operation (this caused the tap to cut out of lead) Use tap holders with length compensation.
<ul style="list-style-type: none"> Tap selected too small for class of thread fit required. 	<ul style="list-style-type: none"> Review markings on tap and determine if it is suitable for class of fit required. If in doubt, contact an EMUGE Representative.

Problem: Tap life too low

Possible Cause	Possible Remedy
<ul style="list-style-type: none"> All reasons stated in torn and rough threads. 	<ul style="list-style-type: none"> See torn and rough threads.
<ul style="list-style-type: none"> Loss of tap hardness by excess heat during regrinding. 	<ul style="list-style-type: none"> Change the specification of the grinding wheel. Use coolant while grinding.
<ul style="list-style-type: none"> Loss of surface treatment from regrinding. 	<ul style="list-style-type: none"> Retreatment of the tap surface. Check suitability of surface treatment for material being tapped.
<ul style="list-style-type: none"> Work hardened drill hole and hole chamfer. 	<ul style="list-style-type: none"> Change or regrind tap drill more frequently. Check proper drilling speed and feed. Anneal part before tapping.

Problem: Tap breakage

Possible Cause	Possible Remedy
<ul style="list-style-type: none"> Improper selection of tap for material and threading application. 	<ul style="list-style-type: none"> Use a suitable tap for the hole style and material being tapped. Reference the EMUGE Tap Finder for proper selection.
<ul style="list-style-type: none"> Tap drill too small. 	<ul style="list-style-type: none"> Use correct size drill. Recommended size drills listed in EMUGE catalog. Note that cutting and roll form taps use different size tap drills for same size thread. If in doubt, contact an EMUGE Representative.
<ul style="list-style-type: none"> Tap hole not deep enough. 	<ul style="list-style-type: none"> Check actual drill depth, drill may have slipped back into holder.
<ul style="list-style-type: none"> Missing tap drill hole. 	<ul style="list-style-type: none"> Ensure tap drill hole is present. Common problem in multiple spindle applications on transfer lines.
<ul style="list-style-type: none"> Chips packing in flutes. 	<ul style="list-style-type: none"> Use tap with different flute geometry/angle. Use a set of taps.
<ul style="list-style-type: none"> Cutting speed too high or low. 	<ul style="list-style-type: none"> Select proper cutting speed. Improve coolant/lubrication to assist the effects of the tap speed.
<ul style="list-style-type: none"> Cold welding on the flanks of the tap (loading). 	<ul style="list-style-type: none"> Use a new tool. Use surface treated taps. Improve coolant/lubrication. Grind away chipped and damaged teeth.
<ul style="list-style-type: none"> Overload of the chamfer teeth. 	<ul style="list-style-type: none"> Use longer chamfer. Increase number of tap flutes to provide more chamfered teeth.
<ul style="list-style-type: none"> Incorrect fixturing or positioning of part. 	<ul style="list-style-type: none"> Use tap holders with axial/parallel floating. Check clamping of part for correct alignment.
<ul style="list-style-type: none"> Tap hitting the bottom of hole. 	<ul style="list-style-type: none"> Use tap holder with length compensation and torque overload system.
<ul style="list-style-type: none"> Tapping hard or high tensile materials. 	<ul style="list-style-type: none"> Check selection of tap, carbide tap may be more suitable than high speed steel taps.





Cut&Form – Production of internal threads by a combination of machining and cold forming

The internal thread production system Cut&Form is a combination of machining and cold-forming processes which each produce a specific part of the thread profile.



- Strengthened threads and increased long-term resistance
- Cold forming of large threads with coarse pitch
- Cold forming of threads in difficult materials
- Production of a narrow-tolerance minor diameter without space pocket
- Extra smooth thread surfaces



Roll Form Taps

	Page
Contents	164 - 165
Product Finder and Cutting Data	166 - 169
Product Pages	170 - 198
Technical Information	199 - 210

- Product Finder
- V_c
- UNC
- UNF
- M
- MF
- G
- STI
- SELF-LOCK
- Tech. Info

Roll form taps with reinforced shank		Roll form taps with reduced shank		Short roll form taps
 Druck 1 InnoForm 1		 Druck 2 InnoForm 2		 Druck
DIN Length ANSI Shank	DIN Length DIN Shank	DIN Length ANSI Shank	DIN Length DIN Shank	ANSI Length ANSI Shank

	Page		Page		Page
UNC	170 - 174		170 - 174		175
UNF	176 - 180		176 - 180		181
M		182 - 187		182 - 187	188
MF		190 - 191		190 - 191	
G				192	
STI-UNC	193		193		
STI-UNF	194		194		
LK-UNC	195		195		
LK-UNF	196		196		
LK-M		197			



	Page
Tapping Fluid 	131
Special Shank Extensions 	132 - 140
EF-Drill C – Chamfer Drills 90° 	412

IKZ

Product Finder

Vc

UNC

UNF

M

MF

G

ST

SELF-LOCK

Tech. Info



Page

170		171	171	171	171	172		172
176		177	177	177	177	177		178
	182	183	183	183	183	183	184	184
		190	190	191				

UNC

UNF

M

MF

G

IKZ

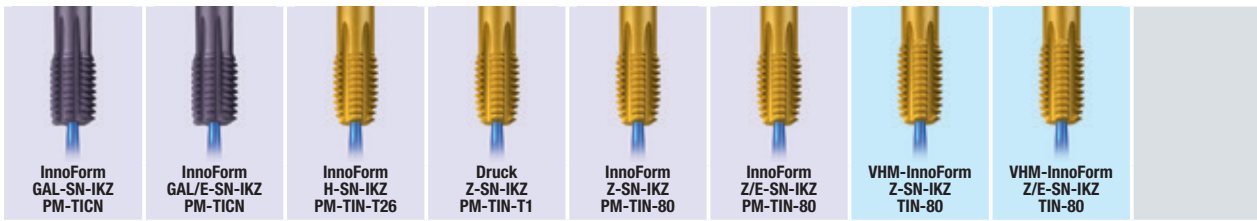

Page

173	173		173	174	174	174	174	
178	179		179	179	180	180	180	
185	185	185		185	186	186	186	
				191				
				192				

UNC

UNF

M

MF

G

IKZN

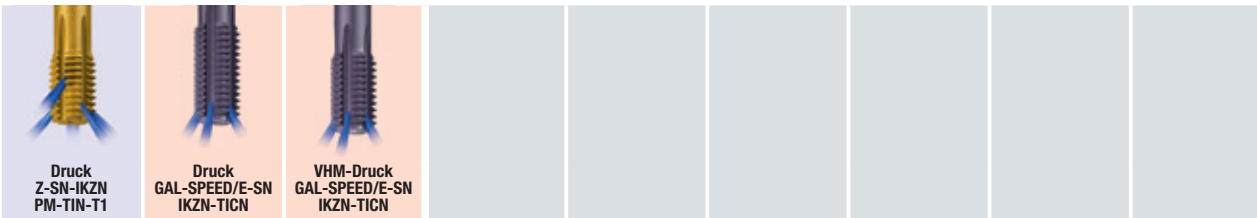

Page

173								
179								
	187	187						
	191	191						

UNC

UNF

M

MF





Druck STEEL NT Druck STEEL TIN



C / 2-3 C / 2-3

Thread Depth and Hole Type

max. 3 x d₁



- UNC
- UNF
- UNEF, UN-8
- M
- MF
- NPSM/NPSC
- NPSF
- Rp (BSPP)
- G
- NPT
- NPTF
- Rc (BSPT)
- STI
- SELF-LOCK

UNC		
UNF		
UNEF, UN-8		
M	182	182
MF		190
NPSM/NPSC		
NPSF		
Rp (BSPP)		192
G		
NPT		
NPTF		
Rc (BSPT)		
STI		
SELF-LOCK		197

Product finder and cutting data

Please note:

The circumferential speeds (v_c in SFM) listed in the respective columns are standard values which have to be adjusted to individual work conditions (material, lubrication, machine etc.).

The suitability is marked as follows:

- Preferred suitable roll form tap
- Suitable roll form tap



= DIN form / threads (Lead taper length)

Application – Material		Hardness Range			Material Examples	v _c [SFM]	v _c [m/min]
		HRC	BHN	N/mm ²			
Steel materials							
P	1.1	Cold-extrusion steels, Construction steels, Free-cutting steels, etc.	≤ 180	≤ 600	1010 / 1018 / 1020 / 12L14 / 12L15 / A36 / T1	49 - 148	66 - 262
	2.1	Construction steels, Cementation steels, Steel castings, etc.	≤ 22	≤ 235	A36 / T1 / 1030-1095 / 4140 / 4340 / 8620	33 - 131	66 - 197
	3.1	Cementation steels, Heat-treatable steels, Cold work steels, etc.	≤ 31	≤ 295	4140 / 4340 / 8620 / P20 / H13 / D2 / A2 / S7 / H1150	16 - 82	33 - 131
	4.1	Heat-treatable steels, Cold work steels, Nitriding steels, etc.	≤ 38	≤ 355	4140 / 4340 / 8620 / P20 / H13 / D2 / 300M / 52100 / M1-M42		
	5.1	High-alloyed steels, Cold work steels, Hot work steels, etc.	≤ 44	≤ 415	4140 / 4340 / 8620 / P20 / H13 / D2 / 300M / 52100		
Stainless steel materials							
M	1.1	Ferritic, martensitic	≤ 29	≤ 280	410 / 440 / 440C / 17-4 PH		33 - 82 ²⁾
	2.1	Austenitic	≤ 29	≤ 280	303 / 304 / 316 / 316L / 321		33 - 82 ²⁾
	3.1	Austenitic-ferritic (Duplex)	≤ 35	≤ 325			
	4.1	Austenitic-ferritic heat-resistant (Super Duplex)	≤ 39	≤ 370			
Cast materials							
K	1.1	Cast iron with lamellar graphite (GJL)		30 - 75	100 - 250	Grey cast irons G10-GG40	
	1.2			75 - 135	250 - 450		
	2.1	Cast iron with nodular graphite (GJS)		105 - 150	350 - 500	Nodular GGG40-GGG70	
	2.2			150 - 265	500 - 900		
	3.1	Cast iron with vermicular graphite (GJV)		90 - 120	300 - 400	Compact graphite iron (CGI)	
	3.2			120 - 150	400 - 500		
	4.1	Malleable cast iron (GTMW, GTMB)		70 - 145	250 - 500	White iron	
4.2			150 - 235	500 - 800			
Non ferrous materials							
Aluminum alloys							
N	1.1	Aluminum wrought alloys		≤ 60	≤ 200	7075	
	1.2			≤ 105	≤ 350	6061-T6 / 2024-T4	
	1.3			≤ 165	≤ 550		
	1.4	Aluminum cast alloys Si ≤ 7%					66 - 197
	1.5	Aluminum cast alloys 7% < Si ≤ 12%					66 - 197
	1.6	Aluminum cast alloys 12% < Si ≤ 17%					
Copper alloys							
N	2.1	Pure copper, low-alloyed copper		≤ 120	≤ 400		66 - 131
	2.2	Copper-zinc alloys (brass, long-chipping)		≤ 165	≤ 550		131 - 262
	2.3	Copper-zinc alloys (brass, short-chipping)		≤ 165	≤ 550		
	2.4	Copper-aluminum alloys (alu bronze, long-chipping)		≤ 235	≤ 800		
	2.5	Copper-tin alloys (tin bronze, long-chipping)		≤ 205	≤ 700		
	2.6	Copper-tin alloys (tin bronze, short-chipping)		≤ 120	≤ 400		
	2.7	Special copper alloys		≤ 180	≤ 600		
	2.8			≤ 44	≤ 415	≤ 1400	
Magnesium alloys							
N	3.1	Magnesium wrought alloys		≤ 150	≤ 500		
	3.2	Magnesium cast alloys		≤ 150	≤ 500		
Synthetics							
N	4.1	Duroplastics (short-chipping)					
	4.2	Thermoplastics (long-chipping)					
	4.3	Fibre-reinforced synthetics (fibre content ≤ 30%)					
	4.4	Fibre-reinforced synthetics (fibre content > 30%)					
Special materials							
S	5.1	Graphite					
	5.2	Tungsten-copper alloys					
	5.3	Composite materials					
Special materials							
Titanium alloys							
S	1.1	Pure titanium		≤ 135	≤ 450	CP1 / CP2	
	1.2	Titanium alloys		≤ 27	≤ 265	6AL4V	
	1.3			≤ 39	≤ 370	≤ 1250	
Nickel alloys, cobalt alloys and iron alloys							
S	2.1	Pure nickel		≤ 180	≤ 600		
	2.2	Nickel-base alloys		≤ 31	≤ 295	Monel 500, 718 Inconel annealed	
	2.3			≤ 49	≤ 475	≤ 1600	718 Inconel
	2.4	Cobalt-base alloys		≤ 31	≤ 295	≤ 1000	
	2.5			≤ 49	≤ 475	≤ 1600	Haynes 25
	2.6	Iron-base alloys		≤ 46	≤ 445	≤ 1500	Incoloy 925
Hard materials							
H	1.1	High strength steels, hardened steels, hard castings		44 - 50			
	1.2			50 - 55			
	1.3			55 - 60			
	1.4			60 - 63			
	1.5			63 - 66			

Druck STEEL-SN NT	Druck STEEL-SN TIN	Druck STEEL-SN TiCN	Druck STEEL-SN IKZ-TiN	Druck STEEL/E-SN TiN	Druck STEEL/E-SN TiCN	VHM-Drück STEEL SN-IKZ	InnoForm STEEL-M-SN PM-TiN-66	InnoForm STEEL-M-SN IKZ-PM-TiN-66	InnoForm STEEL-M/E-SN IKZ-PM-TiN-66	InnoForm STEEL-H-SN PM-TiCN-67	
C / 2-3	C / 2-3	C / 2-3	C / 2-3	E / 1.5-2	E / 1.5-2	C / 2-3	C / 2-3	C / 2-3	E / 1.5-2	C / 2-3	
max. 3 x d ₁ 			max. 3 x d ₁ 		max. 3 x d ₁ 		max. 3 x d ₁ 		max. 3 x d ₁ 		max. 3 x d ₁
170 176	170, 175 176, 181		170 176	170 176	170 176	1)	171 177	171 177	171 177	171 177	
182	182, 188 190					182	183 190	183 190	183 190	183 191	
	192										
	197	193, 194			195, 196						
49 - 148	66 - 262	66 - 262	66 - 262	66 - 262	66 - 262		66 - 262	66 - 262	66 - 262		1.1
33 - 131	66 - 197	66 - 197	66 - 197	66 - 197	66 - 197	33 - 131	66 - 197	66 - 197	66 - 197		2.1
16 - 82	33 - 131	33 - 131	33 - 131	33 - 131	33 - 131	16 - 82	33 - 131	33 - 131	33 - 131	33 - 131	3.1
						7 - 66	33 - 98	33 - 98	33 - 98	33 - 98	4.1
										33 - 66	5.1
	33 - 82 ²⁾	33 - 82 ²⁾	33 - 82 ²⁾	33 - 82 ²⁾	33 - 82 ²⁾						1.1
	33 - 82 ²⁾	33 - 82 ²⁾	33 - 82 ²⁾	33 - 82 ²⁾	33 - 82 ²⁾						2.1
											3.1
											4.1
							66 - 197	66 - 197	66 - 197	66 - 197	1.1
											1.2
											2.1
											2.2
											3.1
											3.2
											4.1
											4.2
											1.1
											1.2
											1.3
	66 - 197	66 - 197	66 - 197	66 - 197	66 - 197	66 - 197	66 - 197	66 - 197	66 - 197	66 - 197	1.4
	66 - 197	66 - 197	66 - 197	66 - 197	66 - 197	66 - 197	66 - 197	66 - 197	66 - 197	66 - 197	1.5
											1.6
											2.1
	66 - 131	66 - 131	66 - 131	66 - 131	66 - 131	66 - 131	66 - 131	66 - 131	66 - 131	66 - 131	2.2
	131 - 262	131 - 262	131 - 262	131 - 262	131 - 262	131 - 262	131 - 262	131 - 262	131 - 262	131 - 262	2.3
											2.4
											2.5
											2.6
											2.7
											2.8
											3.1
											3.2
											4.1
											4.2
											4.3
											4.4
											5.1
											5.2
											5.3
											1.1
											1.2
											1.3
											2.1
											2.2
											2.3
											2.4
											2.5
											2.6
											1.1
											1.2
											1.3
											1.4
											1.5

Product Finder

V_c

UNC

UNF

M

MF

G

STI

SELF-LOCK

Tech. Info



		EMUGE -STEEL-		EMUGE -VA-		EMUGE -AL-			EMUGE -GAL-			EMUGE -H-	
Product Finder													
V _c													
UNC													
UNF													
M													
MF													
G													
STI													
SELF-LOCK													
Tech. Info													
Thread Depth and Hole Type		max. 3 x d ₁ 		max. 3 x d ₁ 		max. 3 x d ₁ 			max. 3 x d ₁ 			max. 3 x d ₁ 	
UNC		171	171	171	172	172		172	173	173	173		
UNF		177		177	177	178		178	178	178	179		
UNEFF, UN-8													
M		183		183	183	184	184	184	184	185	185	185	185
MF		191											
NPSM/NPSC													
NPSF													
Rp (BSPP)													
G													
NPT													
NPTF													
Rc (BSPT)													
STI													
SELF-LOCK													
P	1.1			66 - 262	66 - 262								
	2.1			66 - 197	66 - 197							66 - 197	66 - 197
	3.1	33 - 131	33 - 131	33 - 131	33 - 131							33 - 131	33 - 131
	4.1	33 - 98	33 - 98	33 - 98	33 - 98							33 - 98	33 - 98
	5.1	33 - 66	33 - 66									16 - 66	16 - 66
M	1.1			33 - 82 ²⁾	33 - 82 ²⁾								
	2.1			33 - 82 ²⁾	33 - 82 ²⁾								
	3.1			16 - 66 ²⁾	16 - 66 ²⁾								
	4.1												
K	1.1												
	1.2												
	2.1	66 - 197	66 - 197									66 - 197	66 - 197
	2.2												
	3.1												
	3.2												
	4.2												
N	1.1					66 - 197	66 - 197	66 - 197					
	1.2					66 - 197	66 - 197	66 - 197					
	1.3					66 - 197	66 - 197	66 - 197					
	1.4					66 - 197	66 - 197	66 - 197					
	1.5					66 - 197	66 - 197	66 - 197	66 - 197	66 - 197	66 - 197		
	1.6					66 - 197	66 - 197	66 - 197	66 - 197	66 - 197	66 - 197		
	2.1					66 - 131	66 - 131	66 - 131					
	2.2					131 - 262	131 - 262	131 - 262					
	2.3												
	2.4												
	2.5												
	2.6												
	2.7												
	2.8												
	3.1												
	3.2												
4.1													
4.2													
4.3													
4.4													
5.1													
5.2													
5.3													
S	1.1												
	1.2												
	1.3												
	2.1												
	2.2												
	2.6												
H	1.1												
	1.2												
	1.3												
	1.4												
	1.5												

- Product Finder
- V_c
- UNC
- UNF
- M
- MF
- G
- STI
- SELF-LOCK
- Tech. Info

DIN Length - ANSI Shank

Overall length acc. to DIN 2174

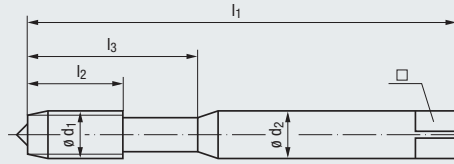

Reinforced Shank
(No.1 - 3/8)

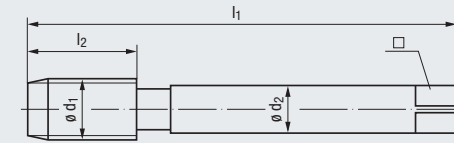

Reduced Shank
(7/16 - 1)

UNC

Unified Coarse Thread
ASME B1.1

Class of Fit
Coating
Cutting Material
Technical Characteristics

Thread Depth and Hole Shape

Applications - Material

STEEL

Steel Materials



2BX	2BX	2BX	2BX	2BX
NT	TIN	TIN	TIN	TICN
HSS Extra	HSS Extra	HSS Extra	HSS Extra	HSS Extra
C / 2-3	C / 2-3	C / 2-3	E / 1.5-2	E / 1.5-2
O / P	E / O / P	E / O	E / O / P	E / O / P

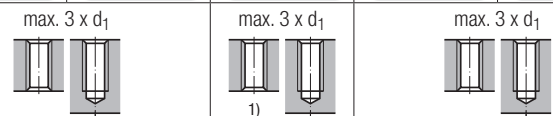

P 1.1-3.1	P 1.1-3.1 M 1.1-2.1²⁾ N 1.4-5, 2.1-2	P 1.1-3.1 M 1.1-2.1²⁾ N 1.4-5, 2.1-2	P 1.1-3.1 M 1.1-2.1²⁾ N 1.4-5, 2.1-2	P 1.1-3.1 M 1.1-2.1²⁾ N 1.4-5, 2.1-2
------------------	--	--	--	--

Reinforced Shank

Nominal Size ø d ₁	T.P.I.	l ₁	l ₂	inch		□	Tool Identification	
				l ₃	ø d ₂		Dimens. ID	Druck 1-STEEL-SN NT
No. 1	64	1.772	0.276	0.472	0.141	0.110	0.0669	.5000
No. 2	56	1.772	0.276	0.472	0.141	0.110	0.0787	.5001
No. 3	48	1.969	0.354	0.551	0.141	0.110	0.0906	.5002
No. 4	40	2.205	0.433	0.709	0.141	0.110	0.1004	.5003
No. 5	40	2.205	0.433	0.709	0.141	0.110	0.1142	.5004
No. 6	32	2.205	0.472	0.787	0.141	0.110	0.1240	.5005
No. 8	32	2.480	0.512	0.827	0.168	0.131	0.1496	.5006
No. 10	24	2.756	0.591	0.984	0.194	0.152	0.1713	.5007
No. 12	24	3.150	0.630	1.142	0.220	0.165	0.1969	.5008
1/4	20	3.150	0.669	1.181	0.255	0.191	0.2264	.5009
5/16	18	3.543	0.787	1.378	0.318	0.238	0.2874	.5010
3/8	16	3.937	0.866	1.535	0.381	0.286	0.3465	.5011

Tool Identification	BU921000	BU921400	BW921400	BU931400	BU939000
Dimens. ID	Druck 1-STEEL-SN NT	Druck 1-STEEL-SN TIN	Druck 1-STEEL-SN IKZ-TIN	Druck 1-STEEL/E-SN TIN	Druck 1-STEEL/E-SN TICN
	•			•	•
	•				
	•	•		•	•
	•	•		•	•
	•	•		•	•
	•	•		•	•
	•	•		•	•
	•	•		•	•
	•	•		•	•
	•	•	•	•	•
	•	•	•	•	•
	•	•	•	•	•

Reduced Shank

Nominal Size ø d ₁	T.P.I.	l ₁	l ₂	inch		□	Tool Identification	
				l ₃	ø d ₂		Dimens. ID	Druck 2-STEEL-SN NT
7/16	14	3.937	0.866	—	0.323	0.242	0.4035	.5012
1/2	13	4.331	0.984	—	0.367	0.275	0.4646	.5013
9/16	12	4.331	1.024	—	0.429	0.322	0.5236	.5014
5/8	11	4.331	1.063	—	0.480	0.360	0.5827	.5015
3/4	10	4.921	1.181	—	0.590	0.442	0.7028	.5016
7/8	9	5.512	1.260	—	0.697	0.523	0.8228	.5017
1	8	6.299	1.417	—	0.800	0.600	0.9409	.5018

Tool Identification	CU921000	CU921400	CW921400		
Dimens. ID	Druck 2-STEEL-SN NT	Druck 2-STEEL-SN TIN	Druck 2-STEEL-SN IKZ-TIN		
	•	•	•		
	•	•	•		
	•	•	•		
	•	•	•		
	•	•	•		
	•	•	•		
	•	•	•		
	•	•	•		
	•	•	•		
	•	•	•		

We recommend a smaller preparatory diameter by 0.002 in for difficult to form materials (such as aluminum cast alloys) for P = 24 T.P.I. and coarser threads. For further information regarding the recommended preparatory diameters, see page 208 - 209.

STEEL Steel Materials						VA Stainless steel materials					
2BX TIN-66 HSSE-PM	2BX TIN-66 HSSE-PM	2BX TIN-66 HSSE-PM	2BX TICN-67 HSSE-PM	2BX TICN-67 HSSE-PM	2BX TICN-67 HSSE-PM	2BX TIN-T26 HSSE-PM	Class of Fit				
C / 2-3 E / O / P	C / 2-3 E / O	E / 1.5-2 E / O	C / 2-3 E / O / P	C / 2-3 E / O	E / 1.5-2 E / O	E / 1.5-2 E / O / P	Coating				
max. 3 x d ₁						max. 3 x d ₁					
P 1.1-4.1 K 2.1	P 1.1-4.1 K 2.1	P 1.1-4.1 K 2.1	P 3.1-5.1 K 2.1	P 3.1-5.1 K 2.1	P 3.1-5.1 K 2.1	P 1.1-4.1 M 1.1-3.1²⁾	Technical Characteristics				
BU377F00						BU396A00					
InnoForm 1-STEEL-M SN-PM TIN-66						InnoForm 1-VA/E-SN PM-TIN-T26					
BU387F00						BU376F00					
InnoForm 1-STEEL-M SN-IKZ-PM TIN-66						InnoForm 1-STEEL-H SN-PM TICN-67					
BU447F00						BU386F00					
InnoForm 1-STEEL-M/E SN-IKZ-PM TIN-66						InnoForm 1-STEEL-H SN-IKZ-PM TICN-67					
BU446F00						CU396A00					
InnoForm 1-STEEL-H/E SN-IKZ-PM TICN-67						InnoForm 2-VA/E-SN PM-TIN-T26					
Tool Identification						Tool Identification					
Dimens. ID						Dimens. ID					
Nominal Size ø d ₁						Nominal Size ø d ₁					
T.P.I.						T.P.I.					
• .5000 No. 1 64						• .5001 No. 2 56					
• .5002 No. 3 48						• .5003 No. 4 40					
• .5004 No. 5 40						• .5005 No. 6 32					
• .5006 No. 8 32						• .5007 No. 10 24					
• .5008 No. 12 24						• .5009 1/4 20					
• .5010 5/16 18						• .5011 3/8 16					
CU377F00						CU376F00					
InnoForm 2-STEEL-M SN-PM TIN-66						InnoForm 2-STEEL-H SN-PM TICN-67					
CU387F00						CU386F00					
InnoForm 2-STEEL-M SN-IKZ-PM TIN-66						InnoForm 2-STEEL-H SN-IKZ-PM TICN-67					
CU446F00						CU396A00					
InnoForm 2-STEEL-H SN-IKZ-PM TICN-67						InnoForm 2-VA/E-SN PM-TIN-T26					
Tool Identification						Tool Identification					
Dimens. ID						Dimens. ID					
Nominal Size ø d ₁						Nominal Size ø d ₁					
T.P.I.						T.P.I.					
• .5012 7/16 14						• .5013 1/2 13					
• .5014 9/16 12						• .5015 5/8 11					
• .5016 3/4 10						• .5017 7/8 9					
• .5018 1 8											

1) Cold-forming in through holes is possible only with external cooling/lubrication
 2) Restricted application possibilities with emulsion
 3) Patent pending

- Product Finder
- V_c
- UNC
- UNF
- M
- MF
- G
- STI
- SELF-LOCK
- Tech. Info

DIN Length - ANSI Shank

Overall length acc. to DIN 2174

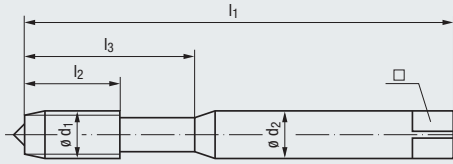

Reinforced Shank
(No.1 - 3/8)

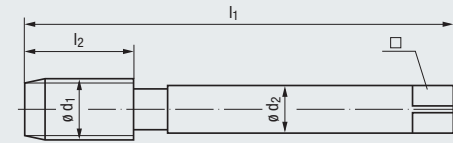

Reduced Shank
(7/16 - 1)

VA
Stainless steel materials



AL
Aluminum Wrought Alloys



UNC

Unified Coarse Thread
ASME B1.1

Class of Fit: 2BX
Coating: TIN-T26
Cutting Material: **HSSE-PM**
Technical Characteristics: E / 1.5-2, E / 0

Thread Depth and Hole Shape

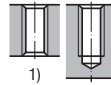

Applications - Material

P 1.1-4.1
M 1.1-3.1²⁾

Class of Fit: 2BX
Coating: GLT-8
Cutting Material: **HSSE-PM**
Technical Characteristics: C / 2-3, E / 0 / P, E / 1.5-2, E / 0

Thread Depth and Hole Shape

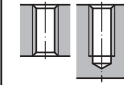

Thread Depth and Hole Shape

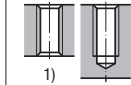

Applications - Material

N 1.1-4, 2.1-2
N 1.1-4, 2.1-2

Reinforced Shank









Nominal Size ø d ₁	T.P.I.	l ₁	l ₂	inch			□	Tool Identification		BU446A00	BU37Y700	BU44Y700
				l ₃	ø d ₂	□		Dimens. ID	InnoForm 1-VA/E-SN IKZ-PM TIN-T26			
No. 1	64	1.772	0.157	0.472	0.141	0.110	0.0669	.5000				
No. 2	56	1.772	0.177	0.472	0.141	0.110	0.0787	.5001				
No. 3	48	1.969	0.197	0.551	0.141	0.110	0.0906	.5002				
No. 4	40	2.205	0.236	0.709	0.141	0.110	0.1004	.5003				
No. 5	40	2.205	0.276	0.709	0.141	0.110	0.1142	.5004				
No. 6	32	2.205	0.276	0.787	0.141	0.110	0.1240	.5005				
No. 8	32	2.480	0.315	0.827	0.168	0.131	0.1496	.5006				
No.10	24	2.756	0.394	0.984	0.194	0.152	0.1713	.5007	•			
No.12	24	3.150	0.394	1.142	0.220	0.165	0.1969	.5008		•		
1/4	20	3.150	0.512	1.181	0.255	0.191	0.2264	.5009	•			
5/16	18	3.543	0.551	1.378	0.318	0.238	0.2874	.5010	•			
3/8	16	3.937	0.630	1.535	0.381	0.286	0.3465	.5011	•			

Reduced Shank

Nominal Size ø d ₁	T.P.I.	l ₁	l ₂	inch			□	Tool Identification		CU446A00	CU37Y700	CU44Y700
				l ₃	ø d ₂	□		Dimens. ID	InnoForm 2-VA/E-SN IKZ-PM TIN-T26			
7/16	14	3.937	0.709	—	0.323	0.242	0.4035	.5012	•			
1/2	13	4.331	0.787	—	0.367	0.275	0.4646	.5013	•			
9/16	12	4.331	0.787	—	0.429	0.322	0.5236	.5014	•			
5/8	11	4.331	0.866	—	0.480	0.360	0.5827	.5015	•			
3/4	10	4.921	0.984	—	0.590	0.442	0.7028	.5016	•			
7/8	9	5.512	1.063	—	0.697	0.523	0.8228	.5017	•			
1	8	6.299	1.181	—	0.800	0.600	0.9409	.5018				

We recommend a smaller preparatory diameter by 0.002 in for difficult to form materials (such as aluminum cast alloys) for P = 24 T.P.I. and coarser threads. For further information regarding the recommended preparatory diameters, see page 208 - 209.

- Product Finder
- V_c
- UNC
- UNF
- M
- MF
- G
- STI
- SELF-LOCK
- Tech. Info

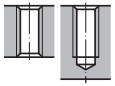
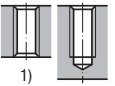
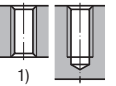
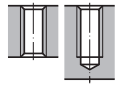
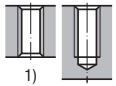
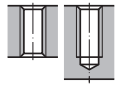
GAL Aluminum Cast Alloys			Z CNC-Controlled Machines						
									
2BX TICN HSSE-PM C / 2-3 E / O / P	2BX TICN HSSE-PM C / 2-3 E / O	2BX TICN HSSE-PM E / 1.5-2 E / O	2BX TIN-T1 HSSE-PM C / 2-3 E / O / P	2BX TIN-T1 HSSE-PM C / 2-3 E / O	2BX TIN-T1 HSSE-PM C / 2-3 E / O	2BX TIN-80 HSSE-PM C / 2-3 E / O / P	Class of Fit Coating Cutting Material Technical Characteristics 		
max. 3 x d ₁ 	max. 3 x d ₁ 	max. 3 x d ₁ 	max. 3 x d ₁ 	max. 3 x d ₁ 	max. 3 x d ₁ 		Thread Depth and Hole Shape		
N 1.4-6	N 1.4-6	N 1.4-6	P 1.1-4.1 M 1.1-3.1²⁾ K 2.1 N 2.1-2, 2.4-5 S 1.1-2.2²⁾ S 2.4²⁾	P 1.1-4.1 M 1.1-3.1²⁾ K 2.1 N 2.1-2, 2.4-5 S 1.1-2.2²⁾ S 2.4²⁾	P 1.1-4.1 M 1.1-3.1²⁾ K 2.1 N 2.1-2, 2.4-5 S 1.1-2.2²⁾ S 2.4²⁾	P 1.1-5.1 M 1.1-3.1²⁾ K 2.1 N 2.1-2, 2.4-5 S 1.1-2.2²⁾ S 2.4²⁾	Applications – Material		
BU37Q200 InnoForm 1-GAL-SN PM-TICN	BU38Q200 InnoForm 1-GAL-SN IKZ-PM-TICN	BU44Q200 InnoForm 1-GAL/E-SN IKZ-PM-TICN	BU92F000 Druck 1-Z-SN PM-TIN-T1	BW92F000 Druck 1-Z-SN- IKZ PM-TIN-T1	BW10F000 Druck 1-Z-SN- IKZN PM-TIN-T1	BU37Z700 InnoForm 1-Z-SN-PM TIN-80	Tool Identification		
							Dimens. ID	Nominal Size $\varnothing d_1$	T.P.I.
							.5000	No. 1	64
							.5001	No. 2	56
							.5002	No. 3	48
							.5003	No. 4	40
							.5004	No. 5	40
							.5005	No. 6	32
							.5006	No. 8	32
							.5007	No. 10	24
							.5008	No. 12	24
							.5009	1/4	20
							.5010	5/16	18
							.5011	3/8	16
CU37Q200 InnoForm 2-GAL-SN PM-TICN	CU38Q200 InnoForm 2-GAL-SN IKZ-PM-TICN	CU44Q200 InnoForm 2-GAL/E-SN IKZ-PM-TICN	CU92F000 Druck 2-Z-SN PM-TIN-T1	CW92F000 Druck 2-Z-SN- IKZ PM-TIN-T1	CW10F000 Druck 2-Z-SN- IKZN PM-TIN-T1	CU37Z700 InnoForm 2-Z-SN-PM TIN-80	Tool Identification		
							Dimens. ID	Nominal Size $\varnothing d_1$	T.P.I.
							.5012	7/16	14
							.5013	1/2	13
							.5014	9/16	12
							.5015	5/8	11
							.5016	3/4	10
							.5017	7/8	9
							.5018	1	8



1) Cold-forming in through holes is possible only with external cooling/lubrication
 2) Restricted application possibilities with emulsion

- Product Finder
- V_c
- UNC
- UNF
- M
- MF
- G
- STI
- SELF-LOCK
- Tech. Info

DIN Length - ANSI Shank

Overall length acc. to DIN 2174

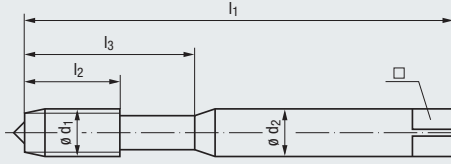

Reinforced Shank
(No.1 - 3/8)

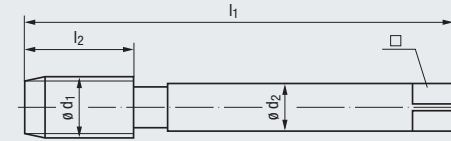

Reduced Shank
(7/16 - 1)

UNC

Unified Coarse Thread
ASME B1.1

Class of Fit: 2BX
Coating: TIN-80
Cutting Material: **HSSE-PM**
Technical Characteristics: C / 2-3, E / 0

Thread Depth and Hole Shape

Applications - Material



2BX	2BX	2BX	2BX	2BX
TIN-80	TIN-80	TIN-80	TIN-80	TIN-80
HSSE-PM	HSSE-PM	HSSE-PM	Carbide	Carbide
C / 2-3	E / 1.5-2	E / 1.5-2	C / 2-3	E / 1.5-2
E / 0	E / 0 / P	E / 0	E / 0	E / 0

max. 3 x d ₁	max. 3 x d ₁	max. 3 x d ₁	
1)	1)	1)	1)
P 1.1-5.1	P 1.1-5.1	P 1.1-5.1	P 2.1-5.1
M 1.1-3.1 2)	M 1.1-3.1 2)	M 1.1-3.1 2)	N 1.4-5, 2.4-5
K 2.1	K 2.1	K 2.1	N 1.4-5, 2.4-5
N 2.1-2, 2.4-5	N 2.1-2, 2.4-5	N 2.1-2, 2.4-5	
S 1.1-2.2 2)	S 1.1-2.2 2)	S 1.1-2.2 2)	
S 2.4 2)	S 2.4 2)	S 2.4 2)	

Reinforced Shank

Nominal Size ø d ₁	T.P.I.	l ₁	l ₂	inch			□	Tool Identification		BU38Z700	BU39Z700	BU44Z700	BU38Z800	BU44Z800
				l ₃	ø d ₂	□		Dimens. ID	InnoForm 1-Z-SN-1KZ PM-TIN-80					
No. 1	64	1.772	0.157	0.472	0.141	0.110	0.0669	.5000						
No. 2	56	1.772	0.177	0.472	0.141	0.110	0.0787	.5001						
No. 3	48	1.969	0.197	0.551	0.141	0.110	0.0906	.5002						
No. 4	40	2.205	0.236	0.709	0.141	0.110	0.1004	.5003						
No. 5	40	2.205	0.276	0.709	0.141	0.110	0.1142	.5004						
No. 6	32	2.205	0.276	0.787	0.141	0.110	0.1240	.5005						
No. 8	32	2.480	0.315	0.827	0.168	0.131	0.1496	.5006						
No.10	24	2.756	0.394	0.984	0.194	0.152	0.1713	.5007						
No.12	24	3.150	0.394	1.142	0.220	0.165	0.1969	.5008						
1/4	20	3.150	0.512	1.181	0.255	0.191	0.2264	.5009						
5/16	18	3.543	0.551	1.378	0.318	0.238	0.2874	.5010						
3/8	16	3.937	0.630	1.535	0.381	0.286	0.3465	.5011						

Reduced Shank

Nominal Size ø d ₁	T.P.I.	l ₁	l ₂	inch			□	Tool Identification		CU38Z700	CU39Z700	CU44Z700
				l ₃	ø d ₂	□		Dimens. ID	InnoForm 2-Z-SN-1KZ PM-TIN-80			
7/16	14	3.937	0.709	—	0.323	0.242	0.4035	.5012				
1/2	13	4.331	0.787	—	0.367	0.275	0.4646	.5013				
9/16	12	4.331	0.787	—	0.429	0.322	0.5236	.5014				
5/8	11	4.331	0.866	—	0.480	0.360	0.5827	.5015				
3/4	10	4.921	0.984	—	0.590	0.442	0.7028	.5016				
7/8	9	5.512	1.063	—	0.697	0.523	0.8228	.5017				
1	8	6.299	1.181	—	0.800	0.600	0.9409	.5018				

We recommend a smaller preparatory diameter by 0.002 in for difficult to form materials (such as aluminum cast alloys) for P = 24 T.P.I. and coarser threads. For further information regarding the recommended preparatory diameters, see page 208 - 209.

ANSI Length • ANSI Shank

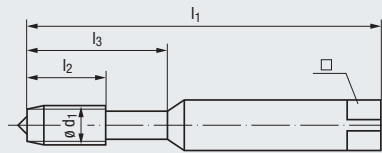

Reinforced Shank
(No. 4 - 3/8)

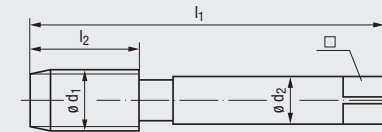

Reduced Shank
(7/16 - 3/4)

STEEL
Steel
Materials



Product
Finder

V_c

UNC

UNF

M

MF

G

STI

SELF-LOCK

Tech. Info

UNC
Unified Coarse Thread
ASME B1.1

Class of Fit
Coating
Cutting Material
Technical Characteristics

- 2BX
- TIN
- HSS Extra
- C / 2-3
- E / O / P

Thread Depth
and Hole Shape

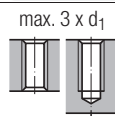

Applications – Material

- P 1.1-3.1
- M 1.1-2.1²⁾
- N 1.4-5, 2.1-2

Tool Identification

AU921400

Druck
STEEL-SN
TIN

Nominal Size ø d ₁	T.P.I.	inch							□	Dimens. ID	Druck STEEL-SN TIN
		l ₁	l ₂	l ₃	ø d ₂	□	□	□			
No. 4	40	1 7/8	1.88	0.433	0.709	0.141	0.110	0.1004	.5003	●	
No. 5	40	1 15/16	1.94	0.433	0.709	0.141	0.110	0.1142	.5004	●	
No. 6	32	2	2.00	0.472	0.748	0.141	0.110	0.1240	.5005	●	
No. 8	32	2 1/8	2.13	0.512	0.827	0.168	0.131	0.1496	.5006	●	
No. 10	24	2 3/8	2.38	0.591	0.945	0.194	0.152	0.1713	.5007	●	
1/4	20	2 1/2	2.50	0.669	1.142	0.255	0.191	0.2264	.5009	●	
5/16	18	2 23/32	2.72	0.787	1.299	0.318	0.238	0.2874	.5010	●	
3/8	16	2 15/16	2.94	0.866	1.378	0.381	0.286	0.3465	.5011	●	
7/16	14	3 5/32	3.16	0.866	—	0.323	0.242	0.4035	.5012	●	
1/2	13	3 3/8	3.38	0.984	—	0.367	0.275	0.4646	.5013	●	
9/16	12	3 19/32	3.59	1.024	—	0.429	0.322	0.5236	.5014	●	
5/8	11	3 13/16	3.81	1.063	—	0.480	0.360	0.5827	.5015	●	
3/4	10	4 1/4	4.25	1.181	—	0.590	0.442	0.7028	.5016	●	

²⁾ Restricted application possibilities with emulsion

We recommend a smaller preparatory diameter by 0.002 in for difficult to form materials (such as aluminum cast alloys) for P = 24 T.P.I. and coarser threads. For further information regarding the recommended preparatory diameters, see page 208 - 209.

DIN Length • ANSI Shank



All ANSI Length • ANSI Shank taps are available in the popular DIN Length • ANSI Shank style.

The DIN Length • ANSI Shank configuration allows for added reach capabilities and greater chip clearance.

- Product Finder
- V_c
- UNC
- UNF
- M
- MF
- G
- STI
- SELF-LOCK
- Tech. Info

DIN Length - ANSI Shank

Overall length acc. to DIN 2174

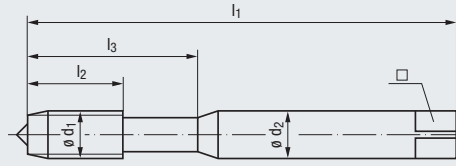

Reinforced Shank
(No.0 - 3/8)

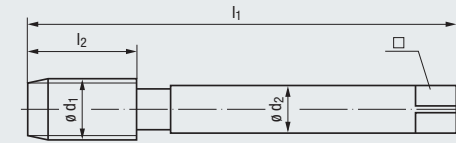

Reduced Shank
(7/16 - 7/8)



UNF
Unified Fine Thread
ASME B1.1

Class of Fit
Coating
Cutting Material
Technical Characteristics

Thread Depth and Hole Shape

Applications - Material

STEEL
Steel
Materials



2BX	2BX	2BX	2BX	2BX
NT	TIN	TIN	TIN	TICN
HSS Extra	HSS Extra	HSS Extra	HSS Extra	HSS Extra
C / 2-3	C / 2-3	C / 2-3	E / 1.5-2	E / 1.5-2
O / P	E / O / P	E / O	E / O / P	E / O / P

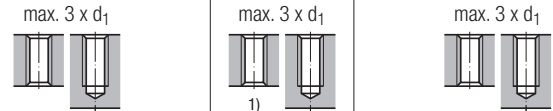

P 1.1-3.1	P 1.1-3.1 M 1.1-2.1²⁾ N 1.4-5, 2.1-2	P 1.1-3.1 M 1.1-2.1²⁾ N 1.4-5, 2.1-2	P 1.1-3.1 M 1.1-2.1²⁾ N 1.4-5, 2.1-2	P 1.1-3.1 M 1.1-2.1²⁾ N 1.4-5, 2.1-2
------------------	--	--	--	--

Reinforced Shank

Nominal Size ø d ₁	T.P.I.	l ₁	l ₂	inch			Tool Identification		BU921000	BU921400	BW921400	BU931400	BU939000
				l ₃	ø d ₂	□	Dimens. ID	Druck 1-STEEL-SN NT					
No. 0	80	1.626	0.236	0.433	0.141	0.110	0.0551	.5033	●				
No. 1	72	1.772	0.276	0.472	0.141	0.110	0.0669	.5034	●				
No. 2	64	1.772	0.276	0.472	0.141	0.110	0.0795	.5035	●				
No. 3	56	1.969	0.354	0.551	0.141	0.110	0.0913	.5036	●				
No. 4	48	2.205	0.433	0.709	0.141	0.110	0.1031	.5037	●	●			
No. 5	44	2.205	0.433	0.709	0.141	0.110	0.1150	.5038	●	●			
No. 6	40	2.205	0.472	0.787	0.141	0.110	0.1268	.5039	●	●			
No. 8	36	2.480	0.512	0.827	0.168	0.131	0.1516	.5040	●	●			
No. 10	32	2.756	0.512	0.984	0.194	0.152	0.1752	.5041	●	●	●		●
No. 12	28	3.150	0.630	1.142	0.220	0.165	0.2008	.5042	●	●		●	
1/4	28	3.150	0.669	1.181	0.255	0.191	0.2343	.5043	●	●	●	●	●
5/16	24	3.543	0.669	1.260	0.318	0.238	0.2933	.5044	●	●	●	●	●
3/8	24	3.937	0.709	1.535	0.381	0.286	0.3563	.5045	●	●	●	●	●

Reduced Shank

Nominal Size ø d ₁	T.P.I.	l ₁	l ₂	inch			Tool Identification		CU921000	CU921400			
				l ₃	ø d ₂	□	Dimens. ID	Druck 2-STEEL-SN NT					
7/16	20	3.937	0.866	—	0.323	0.242	0.4154	.5046	●	●			
1/2	20	3.937	0.866	—	0.367	0.275	0.4783	.5047	●	●			
9/16	18	3.937	0.866	—	0.429	0.322	0.5374	.5048	●				
5/8	18	3.937	0.866	—	0.480	0.360	0.6004	.5049	●	●			
3/4	16	4.331	0.984	—	0.590	0.442	0.7224	.5050	●	●			
7/8	14	4.921	1.024	—	0.697	0.523	0.8425	.5051	●	●			

We recommend a smaller preparatory diameter by 0.002 in for difficult to form materials (such as aluminum cast alloys) for P = 24 T.P.I. and coarser threads. For further information regarding the recommended preparatory diameters, see page 208 - 209.

STEEL Steel Materials					VA Stainless steel materials				
new	new	new	new	new	new	new			
$l_2 = 10 \times P$ 3)	$l_2 = 10 \times P$ 3)	$l_2 = 10 \times P$ 3)	$l_2 = 10 \times P$ 3)	$l_2 = 10 \times P$ 3)	$l_2 = 10 \times P$ 3)	$l_2 = 10 \times P$ 3)			
2BX	2BX	2BX	2BX	2BX	2BX	2BX	Class of Fit		
TIN-66	TIN-66	TIN-66	TICN-67	TICN-67	TIN-T26	TIN-T26	Coating		
HSSE-PM	HSSE-PM	HSSE-PM	HSSE-PM	HSSE-PM	HSSE-PM	HSSE-PM	Cutting Material		
C / 2-3	C / 2-3	E / 1.5-2	C / 2-3	C / 2-3	E / 1.5-2	E / 1.5-2	Technical Characteristics		
E / O / P	E / O	E / O	E / O / P	E / O	E / O / P	E / O			
max. 3 x d ₁ 	max. 3 x d ₁ 	max. 3 x d ₁ 	max. 3 x d ₁ 	max. 3 x d ₁ 	max. 3 x d ₁ 	max. 3 x d ₁ 	Thread Depth and Hole Shape		
P 1.1-4.1	P 1.1-4.1	P 1.1-4.1	P 3.1-5.1	P 3.1-5.1	P 1.1-4.1	P 1.1-4.1	Applications – Material		
K 2.1	K 2.1	K 2.1	K 2.1	K 2.1	M 1.1-3.1 2)	M 1.1-3.1 2)			
BU377F00	BU387F00	BU447F00	BU376F00	BU386F00	BU396A00	BU446A00	Tool Identification		
InnoForm 1-STEEL-M SN-PM TIN-66	InnoForm 1-STEEL-M SN-IKZ-PM TIN-66	InnoForm 1-STEEL-M/E SN-IKZ-PM TIN-66	InnoForm 1-STEEL-H SN-PM TICN-67	InnoForm 1-STEEL-H SN-IKZ-PM TICN-67	InnoForm 1-VA/E-SN PM-TIN-T26	InnoForm 1-VA/E-SN IKZ-PM TIN-T26	Dimens. ID	Nominal Size ø d₁	T.P.I.
							.5033	No. 0	80
							.5034	No. 1	72
							.5035	No. 2	64
							.5036	No. 3	56
							.5037	No. 4	48
							.5038	No. 5	44
							.5039	No. 6	40
							.5040	No. 8	36
•	•	•	•	•		•	.5041	No.10	32
							.5042	No.12	28
•	•	•	•	•		•	.5043	1/4	28
•	•	•	•	•		•	.5044	5/16	24
•	•	•	•	•		•	.5045	3/8	24
CU377F00	CU387F00	CU447F00	CU376F00	CU386F00	CU396A00	CU446A00	Tool Identification		
InnoForm 2-STEEL-M SN-PM TIN-66	InnoForm 2-STEEL-M SN-IKZ-PM TIN-66	InnoForm 2-STEEL-M/E SN-IKZ-PM TIN-66	InnoForm 2-STEEL-H SN-PM TICN-67	InnoForm 2-STEEL-H SN-IKZ-PM TICN-67	InnoForm 2-VA/E-SN PM-TIN-T26	InnoForm 2-VA/E-SN IKZ-PM TIN-T26	Dimens. ID	Nominal Size ø d₁	T.P.I.
•	•	•	•	•		•	.5046	7/16	20
•	•	•	•	•		•	.5047	1/2	20
•	•	•	•	•		•	.5048	9/16	18
•	•	•	•	•		•	.5049	5/8	18
•	•	•	•	•		•	.5050	3/4	16
							.5051	7/8	14

1) Cold-forming in through holes is possible only with external cooling/lubrication

2) Restricted application possibilities with emulsion

3) Patent pending

- Product Finder
- V_c
- UNC
- UNF
- M
- MF
- G
- STI
- SELF-LOCK
- Tech. Info

DIN Length - ANSI Shank

Overall length acc. to DIN 2174

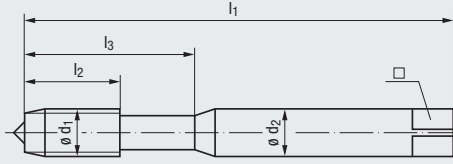

Reinforced Shank
(No.0 - 3/8)

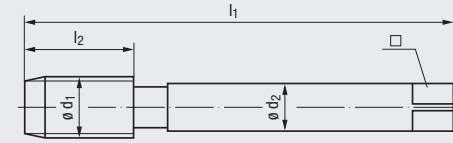

Reduced Shank
(7/16 - 7/8)



UNF
Unified Fine Thread
ASME B1.1

Class of Fit: 2BX
Coating: GLT-8
Cutting Material: **HSSE-PM**
Technical Characteristics: C / 2-3, E / 0 / P

Thread Depth and Hole Shape

Applications - Material

2BX	2BX	2BX	2BX
GLT-8	GLT-8	TICN	TICN
HSSE-PM	HSSE-PM	HSSE-PM	HSSE-PM
C / 2-3	E / 1.5-2	C / 2-3	C / 2-3
E / 0 / P	E / 0	E / 0 / P	E / 0
max. 3 x d ₁	max. 3 x d ₁	max. 3 x d ₁	max. 3 x d ₁
N 1.1-4, 2.1-2	N 1.1-4, 2.1-2	N 1.4-6	N 1.4-6







Reinforced Shank

Nominal Size ø d ₁	T.P.I.	l ₁	l ₂	inch		□	Tool Identification		BU37Y700	BU44Y700	BU37Q200	BU38Q200
				l ₃	ø d ₂		Dimens. ID	InnoForm 1-AL-SN-PM GLT-8				
No. 0	80	1.626	0.157	0.433	0.141	0.110	0.0551	.5033				
No. 1	72	1.772	0.157	0.472	0.141	0.110	0.0669	.5034				
No. 2	64	1.772	0.177	0.472	0.141	0.110	0.0795	.5035	●		●	
No. 3	56	1.969	0.197	0.551	0.141	0.110	0.0913	.5036	●		●	
No. 4	48	2.205	0.236	0.709	0.141	0.110	0.1031	.5037	●		●	
No. 5	44	2.205	0.276	0.709	0.141	0.110	0.1150	.5038	●		●	
No. 6	40	2.205	0.276	0.787	0.141	0.110	0.1268	.5039	●		●	
No. 8	36	2.480	0.315	0.827	0.168	0.131	0.1516	.5040	●		●	
No. 10	32	2.756	0.394	0.984	0.194	0.152	0.1752	.5041	●	●	●	●
No. 12	28	3.150	0.394	1.142	0.220	0.165	0.2008	.5042	●		●	
1/4	28	3.150	0.394	1.181	0.255	0.191	0.2343	.5043	●	●	●	●
5/16	24	3.543	0.394	1.260	0.318	0.238	0.2933	.5044	●	●	●	●
3/8	24	3.937	0.394	1.535	0.381	0.286	0.3563	.5045	●	●	●	●

Reduced Shank

Nominal Size ø d ₁	T.P.I.	l ₁	l ₂	inch		□	Tool Identification		CU37Y700	CU44Y700	CU37Q200	CU38Q200
				l ₃	ø d ₂		Dimens. ID	InnoForm 2-AL-SN-PM GLT-8				
7/16	20	3.937	0.512	—	0.323	0.242	0.4154	.5046	●	●	●	●
1/2	20	3.937	0.512	—	0.367	0.275	0.4783	.5047	●	●	●	●
9/16	18	3.937	0.591	—	0.429	0.322	0.5374	.5048	●	●	●	●
5/8	18	3.937	0.591	—	0.480	0.360	0.6004	.5049	●	●	●	●
3/4	16	4.331	0.669	—	0.590	0.442	0.7224	.5050	●	●	●	●
7/8	14	4.921	0.669	—	0.697	0.523	0.8425	.5051	●	●	●	●

We recommend a smaller preparatory diameter by 0.002 in for difficult to form materials (such as aluminum cast alloys) for P = 24 T.P.I. and coarser threads. For further information regarding the recommended preparatory diameters, see page 208 - 209.

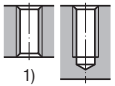
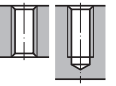
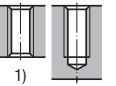
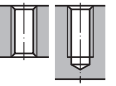
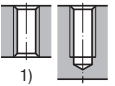
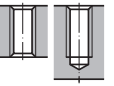
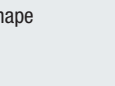
GAL Aluminum Cast Alloys		Z CNC-Controlled Machines								
										
2BX TICN HSSE-PM E / 1.5-2 E / O		2BX TIN-T1 HSSE-PM C / 2-3 E / O / P	2BX TIN-T1 HSSE-PM C / 2-3 E / O	2BX TIN-T1 HSSE-PM C / 2-3 E / O	2BX TIN-80 HSSE-PM C / 2-3 E / O / P	2BX TIN-80 HSSE-PM C / 2-3 E / O	2BX TIN-80 HSSE-PM E / 1.5-2 E / O / P	Class of Fit Coating Cutting Material Technical Characteristics		
max. 3 x d ₁ 		max. 3 x d ₁ 	max. 3 x d ₁ 	max. 3 x d ₁ 	max. 3 x d ₁ 	max. 3 x d ₁ 	max. 3 x d ₁ 	Thread Depth and Hole Shape		
N 1.4-6		P 1.1-4.1 M 1.1-3.1 ²⁾ K 2.1 N 2.1-2, 2.4-5 S 1.1-2.2 ²⁾ S 2.4 ²⁾	P 1.1-4.1 M 1.1-3.1 ²⁾ K 2.1 N 2.1-2, 2.4-5 S 1.1-2.2 ²⁾ S 2.4 ²⁾	P 1.1-4.1 M 1.1-3.1 ²⁾ K 2.1 N 2.1-2, 2.4-5 S 1.1-2.2 ²⁾ S 2.4 ²⁾	P 1.1-5.1 M 1.1-3.1 ²⁾ K 2.1 N 2.1-2, 2.4-5 S 1.1-2.2 ²⁾ S 2.4 ²⁾	P 1.1-5.1 M 1.1-3.1 ²⁾ K 2.1 N 2.1-2, 2.4-5 S 1.1-2.2 ²⁾ S 2.4 ²⁾	P 1.1-5.1 M 1.1-3.1 ²⁾ K 2.1 N 2.1-2, 2.4-5 S 1.1-2.2 ²⁾ S 2.4 ²⁾	Applications – Material		
BU44Q200 InnoForm 1-GAL/E-SN IKZ-PM-TICN		BU92F000 Druck 1-Z-SN PM-TIN-T1	BW92F000 Druck 1-Z-SN- IKZ PM-TIN-T1	BW10F000 Druck 1-Z-SN- IKZN PM-TIN-T1	BU37Z700 InnoForm 1-Z-SN-PM TIN-80	BU38Z700 InnoForm 1-Z-SN- IKZ PM-TIN-80	BU39Z700 InnoForm 1-Z/E-SN PM-TIN-80	Tool Identification		
								Dimens. ID	Nominal Size ø d ₁	T.P.I.
								.5033	No. 0	80
								.5034	No. 1	72
								.5035	No. 2	64
								.5036	No. 3	56
								.5037	No. 4	48
								.5038	No. 5	44
								.5039	No. 6	40
								.5040	No. 8	36
								.5041	No.10	32
								.5042	No.12	28
								.5043	1/4	28
								.5044	5/16	24
								.5045	3/8	24
CU44Q200 InnoForm 2-GAL/E-SN IKZ-PM-TICN		CU92F000 Druck 2-Z-SN PM-TIN-T1	CW92F000 Druck 2-Z-SN- IKZ PM-TIN-T1	CW10F000 Druck 2-Z-SN- IKZN PM-TIN-T1	CU37Z700 InnoForm 2-Z-SN-PM TIN-80	CU38Z700 InnoForm 2-Z-SN- IKZ PM-TIN-80	CU39Z700 InnoForm 2-Z/E-SN PM-TIN-80	Tool Identification		
								Dimens. ID	Nominal Size ø d ₁	T.P.I.
								.5046	7/16	20
								.5047	1/2	20
								.5048	9/16	18
								.5049	5/8	18
								.5050	3/4	16
								.5051	7/8	14

1) Cold-forming in through holes is possible only with external cooling/lubrication
2) Restricted application possibilities with emulsion

Product
Finder

V_c

UNC

UNF

M

MF

G

ST

SELF-LOCK

Tech. Info



- Product Finder
- V_c
- UNC
- UNF
- M
- MF
- G
- STI
- SELF-LOCK
- Tech. Info

DIN Length - ANSI Shank

Overall length acc. to DIN 2174

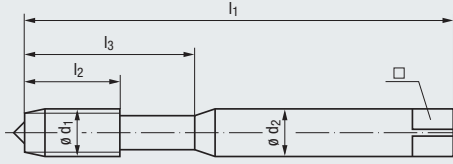

Reinforced Shank
(No.0 - 3/8)

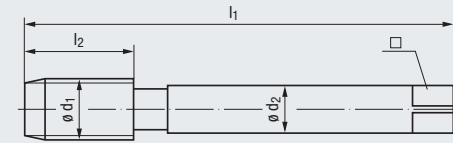

Reduced Shank
(7/16 - 7/8)



UNF
Unified Fine Thread
ASME B1.1

Class of Fit

Coating

Cutting Material

Technical Characteristics



Thread Depth
and Hole Shape

Applications - Material

Z
CNC-Controlled
Machines

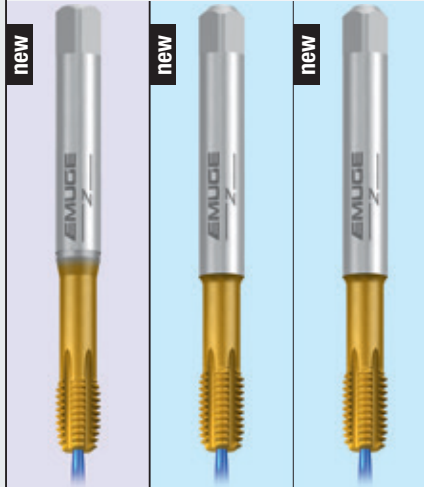

2BX	2BX	2BX
TIN-80	TIN-80	TIN-80
HSSE-PM	Carbide	Carbide
E / 1.5-2	C / 2-3	E / 1.5-2
E / 0	E / 0	E / 0

max. 3 x d₁

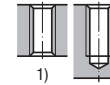

P 1.1-5.1	P 2.1-5.1	P 2.1-5.1
M 1.1-3.1 ²⁾	N 1.4-5, 2.4-5	N 1.4-5, 2.4-5
K 2.1		
N 2.1-2, 2.4-5		
S 1.1-2.2 ²⁾		
S 2.4 ²⁾		

Reinforced Shank

Nominal Size ø d ₁	T.P.I.	mm		inch			□
		l ₁	l ₂	l ₃	ø d ₂	□	
No. 0	80	1.626	0.157	0.433	0.141	0.110	
No. 1	72	1.772	0.157	0.472	0.141	0.110	
No. 2	64	1.772	0.177	0.472	0.141	0.110	
No. 3	56	1.969	0.197	0.551	0.141	0.110	
No. 4	48	2.205	0.236	0.709	0.141	0.110	
No. 5	44	2.205	0.276	0.709	0.141	0.110	
No. 6	40	2.205	0.276	0.787	0.141	0.110	
No. 8	36	2.480	0.315	0.827	0.168	0.131	
No. 10	32	2.756	0.394	0.984	0.194	0.152	
No. 12	28	3.150	0.394	1.142	0.220	0.165	
1/4	28	3.150	0.394	1.181	0.255	0.191	
5/16	24	3.543	0.394	1.260	0.318	0.238	
3/8	24	3.937	0.394	1.535	0.381	0.286	

Tool Identification



Dimens. ID

Tool Identification	BU44Z700	BU38Z800	BU44Z800
InnoForm 1-Z/E-SN-IKZ PM-TIN-80			
VHM InnoForm 1-Z-SN-IKZ TIN-80			
VHM InnoForm 1-Z/E-SN-IKZ TIN-80			

Reduced Shank

Nominal Size ø d ₁	T.P.I.	mm		inch			□
		l ₁	l ₂	l ₃	ø d ₂	□	
7/16	20	3.937	0.512	—	0.323	0.242	
1/2	20	3.937	0.512	—	0.367	0.275	
9/16	18	3.937	0.591	—	0.429	0.322	
5/8	18	3.937	0.591	—	0.480	0.360	
3/4	16	4.331	0.669	—	0.590	0.442	
7/8	14	4.921	0.669	—	0.697	0.523	

Tool Identification



Dimens. ID

Tool Identification	CU44Z700		
InnoForm 2-Z/E-SN-IKZ PM-TIN-80			



We recommend a smaller preparatory diameter by 0.002 in for difficult to form materials (such as aluminum cast alloys) for P = 24 T.P.I. and coarser threads. For further information regarding the recommended preparatory diameters, see page 208 - 209.

ANSI Length • ANSI Shank

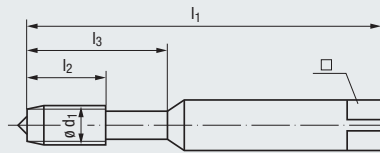

Reinforced Shank
(No.6 - 3/8)

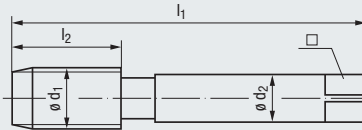

Reduced Shank
(7/16 - 3/4)

STEEL
Steel
Materials



- Product Finder
- Vc
- UNC
- UNF**
- M
- MF
- G
- ST
- SELF-LOCK
- Tech. Info

UNF

**Unified Fine Thread
ASME B1.1**

- Class of Fit: 2BX
- Coating: TIN
- Cutting Material: HSS Extra
- Technical Characteristics: C / 2-3, E / O / P

Thread Depth and Hole Shape

max. 3 x d₁

- Applications – Material
- P 1.1-3.1
 - M 1.1-2.1²⁾
 - N 1.4-5, 2.1-2

Tool Identification AU921400

Nominal Size ø d ₁	T.P.I.	inch				ø d ₂	□	Tool ID	Dimens. ID	Druck STEEL-SN TIN
		l ₁	l ₂	l ₃	□					
No. 6	40	2	2.00	0.472	0.748	0.141	0.110	0.1268	.5039	●
No. 8	36	2 1/8	2.13	0.512	0.827	0.168	0.131	0.1516	.5040	●
No. 10	32	2 3/8	2.38	0.591	0.945	0.194	0.152	0.1752	.5041	●
1/4	28	2 1/2	2.50	0.669	1.142	0.255	0.191	0.2343	.5043	●
5/16	24	2 23/32	2.72	0.669	1.299	0.318	0.238	0.2933	.5044	●
3/8	24	2 15/16	2.94	0.709	1.378	0.381	0.286	0.3563	.5045	●
7/16	20	3 5/32	3.16	0.866	—	0.323	0.242	0.4154	.5046	●
1/2	20	3 3/8	3.38	0.866	—	0.367	0.275	0.4783	.5047	●
9/16	18	3 19/32	3.59	0.866	—	0.429	0.322	0.5374	.5048	●
5/8	18	3 13/16	3.81	0.866	—	0.480	0.360	0.6004	.5049	●
3/4	16	4 1/4	4.25	0.984	—	0.590	0.442	0.7224	.5050	●

1) Cold-forming in through holes is possible only with external cooling/lubrication
2) Restricted application possibilities with emulsion

We recommend a smaller preparatory diameter by 0.002 in for difficult to form materials (such as aluminum cast alloys) for P = 24 T.P.I. and coarser threads. For further information regarding the recommended preparatory diameters, see page 208 - 209.

DIN Length • ANSI Shank



All ANSI Length • ANSI Shank taps are available in the popular DIN Length • ANSI Shank style.

The DIN Length • ANSI Shank configuration allows for added reach capabilities and greater chip clearance.

- Product Finder
- V_c
- UNC
- UNF
- M**
- MF
- G
- STI
- SELF-LOCK
- Tech. Info

DIN Length • DIN Shank

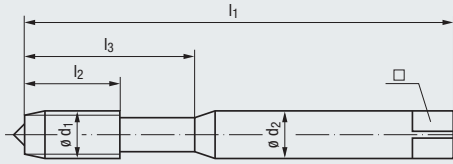

Reinforced Shank
(M2 - M10)

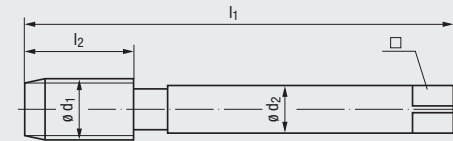

Reduced Shank
(M12 - M20)

M

**ISO Metric Coarse Thread
DIN 13**

Class of Fit
Coating
Cutting Material
Technical Characteristics

Thread Depth
and Hole Shape

Applications – Material

STEEL
Steel
Materials

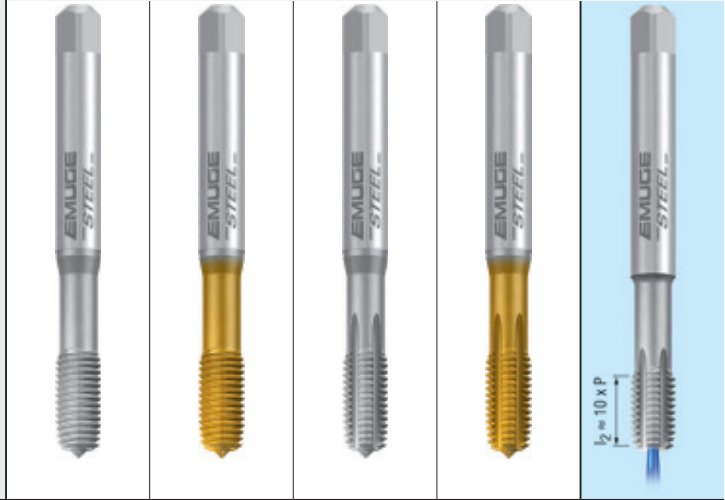

6HX	6HX	6HX	6HX	6HX
NT	TIN	NT	TIN	Carbide
HSS Extra	HSS Extra	HSS Extra	HSS Extra	Carbide
C / 2-3	C / 2-3	C / 2-3	C / 2-3	C / 2-3
O / P	E / O / P	O / P	E / O / P	E / O

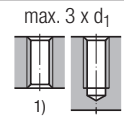
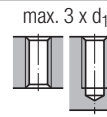

P 1.1-3.1	P 1.1-3.1 M 1.1-2.1²⁾ N 1.4-5, 2.1-2	P 1.1-3.1	P 1.1-3.1 M 1.1-2.1²⁾ N 1.4-5, 2.1-2	P 2.1-4.1 N 1.4-5
------------------	--	------------------	--	------------------------------------

Reinforced Shank

Nominal Size ø d ₁	P	mm			ø d ₂	□	Tool Identification		B0911000	B0911400	B0921000	B0921400	B1970100
		l ₁	l ₂	l ₃			Dimens. ID	Druck 1-STEEL NT	Druck 1-STEEL TIN	Druck 1-STEEL-SN NT	Druck 1-STEEL-SN TIN	VHM Druck 1-STEEL SN-IKZ	
M 2	0.4	45	7	12	2.8	2.1	1.85	.0020	★	★		★	
M 2.5	0.45	50	9	14	2.8	2.1	2.33	.0025	★	★		★	
M 3	0.5	56	11	18	3.5	2.7	2.8	.0030	★	★	●	●	
M 3.5	0.6	56	12	20	4	3	3.25	.0035	★	★		★	
M 4	0.7	63	13	21	4.5	3.4	3.7	.0040	★	★	●	●	
M 4.5	0.75	70	14	25	6	4.9	4.2	.0045					
M 5	0.8	70	15	25	6	4.9	4.65	.0050	★	★	●	●	★
M 6	1	80	17	30	6	4.9	5.6	.0060	★	★	●	●	★
M 8	1.25	90	20	35	8	6.2	7.45	.0080	★	★	●	●	★
M 10	1.5	100	22	39	10	8	9.35	.0100	★	★	●	●	★

Reduced Shank









Nominal Size ø d ₁	P	mm			ø d ₂	□	Tool Identification			C0911400		C0921400	
		l ₁	l ₂	l ₃			Dimens. ID	Druck 2-STEEL TIN	Druck 2-STEEL-SN TIN				
M 12	1.75	110	24	—	9	7	11.25	.0112		★		●	
M 14	2	110	26	—	11	9	13.1	.0114		★		★	
M 16	2	110	27	—	12	9	15.1	.0116		★		●	
M 18	2.5	125	30	—	14	11	16.85	.0118					
M 20	2.5	140	32	—	16	12	18.85	.0120					

¹⁾ Cold-forming in through holes is possible only with external cooling/lubrication
²⁾ Restricted application possibilities with emulsion



We recommend a smaller preparatory diameter by 0.05 mm for difficult to form materials (such as aluminum cast alloys) for P ≥ 1 mm.
 For further information regarding the recommended preparatory diameters, see page 208 - 209.

- Product Finder
- V_c
- UNC
- UNF
- M**
- MF
- G
- STI
- SELF-LOCK
- Tech. Info

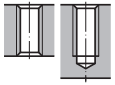
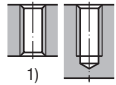
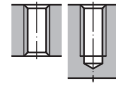
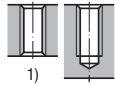
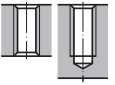
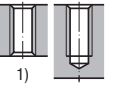
STEEL Steel Materials					VA Stainless steel materials				
									
new	new	new	new	new	new	new			
$l_2 = 10 \times P$ 3)	$l_2 = 10 \times P$ 3)	$l_2 = 10 \times P$ 3)	$l_2 = 10 \times P$ 3)	$l_2 = 10 \times P$ 3)	$l_2 = 10 \times P$	$l_2 = 10 \times P$			
6HX TIN-66 HSSE-PM	6HX TIN-66 HSSE-PM	6HX TIN-66 HSSE-PM	6HX TIN HSSE-PM	6HX TICN-67 HSSE-PM	6HX TIN-T26 HSSE-PM	6HX TIN-T26 HSSE-PM	Class of Fit Coating Cutting Material Technical Characteristics		
C / 2-3 E / O / P	C / 2-3 E / O	E / 1.5-2 E / O	C / 2-3 E / O / P	C / 2-3 E / O	E / 1.5-2 E / O / P	E / 1.5-2 E / O	 		
max. 3 x d ₁ 	max. 3 x d ₁ 	max. 3 x d ₁ 	max. 3 x d ₁ 		max. 3 x d ₁ 	max. 3 x d ₁ 	Thread Depth and Hole Shape		
P 1.1-4.1 K 2.1	P 1.1-4.1 K 2.1	P 1.1-4.1 K 2.1	P 3.1-5.1 K 2.1	P 3.1-5.1 K 2.1	P 1.1-4.1 M 1.1-3.1 2)	P 1.1-4.1 M 1.1-3.1 2)	Applications – Material		
B5217F00 InnoForm 1-STEEL-M SN-PM TIN-66	B5237F00 InnoForm 1-STEEL-M SN-IKZ-PM TIN-66	B5317F00 InnoForm 1-STEEL-M/E SN-IKZ-PM TIN-66	B5216F00 InnoForm 1-STEEL-H SN-PM TICN-67	B5236F00 InnoForm 1-STEEL-H SN-IKZ-PM TICN-67	B5296A00 InnoForm 1-VA/E-SN PM-TIN-T26	B5316A00 InnoForm 1-VA/E-SN IKZ-PM TIN-T26	Tool Identification		
							Dimens. ID	Nominal Size ø d ₁	P
							.0020	M 2	0.4
							.0025	M 2.5	0.45
							.0030	M 3	0.5
							.0035	M 3.5	0.6
							.0040	M 4	0.7
							.0045	M 4.5	0.75
							.0050	M 5	0.8
							.0060	M 6	1
							.0080	M 8	1.25
							.0100	M 10	1.5
C5217F00 InnoForm 2-STEEL-M SN-PM TIN-66	C5237F00 InnoForm 2-STEEL-M SN-IKZ-PM TIN-66	C5317F00 InnoForm 2-STEEL-M/E SN-IKZ-PM TIN-66	C5216F00 InnoForm 2-STEEL-H SN-PM TICN-67	C5236F00 InnoForm 2-STEEL-H SN-IKZ-PM TICN-67			Tool Identification		
							Dimens. ID	Nominal Size ø d ₁	P
							.0112	M 12	1.75
							.0114	M 14	2
							.0116	M 16	2
							.0118	M 18	2.5
							.0120	M 20	2.5

1) Cold-forming in through holes is possible only with external cooling/lubrication
 2) Restricted application possibilities with emulsion
 3) Patent pending

- Product Finder
- V_c
- UNC
- UNF
- M
- MF
- G
- STI
- SELF-LOCK
- Tech. Info

DIN Length • DIN Shank

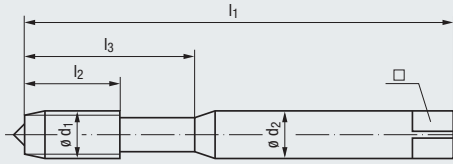

Reinforced Shank
(M2 - M10)

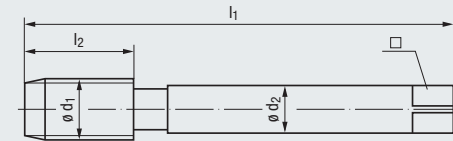

Reduced Shank
(M12 - M20)

M

**ISO Metric Coarse Thread
DIN 13**

Class of Fit
Coating
Cutting Material
Technical Characteristics

Thread Depth and Hole Shape

Applications – Material

	AL Aluminum Wrought Alloys			GAL Aluminum Cast Alloys
new				
Class of Fit	6HX	6HX	6HX	6HX
Coating	GLT-8	GLT-8	GLT-8	TICN
Cutting Material	HSSE-PM	HSSE-PM	HSSE-PM	HSSE-PM
Technical Characteristics	C / 2-3 E / O / P	C / 2-3 E / O	E / 1.5-2 E / O	C / 2-3 E / O / P
Thread Depth and Hole Shape	max. 3 x d ₁ 	max. 3 x d ₁ 	max. 3 x d ₁ 	max. 3 x d ₁
Applications – Material	N 1.1-4, 2.1-2	N 1.1-4, 2.1-2	N 1.1-4, 2.1-2	N 1.4-6

Reinforced Shank

Nominal Size ø d ₁	P	mm					ø d ₂	□	Tool Identification		B521Y700	B523Y700	B531Y700	B521Q200
		l ₁	l ₂	l ₃	Ø	□			Dimens. ID	InnoForm 1-AL-SN-PM GLT-8				
M 2	0.4	45	4	12	2.8	2.1	1.85	.0020	★					
M 2.5	0.45	50	5	14	2.8	2.1	2.33	.0025	★					
M 3	0.5	56	6	18	3.5	2.7	2.8	.0030	★					
M 3.5	0.6	56	7	20	4	3	3.25	.0035						
M 4	0.7	63	7	21	4.5	3.4	3.7	.0040	★	★		★		
M 4.5	0.75	70	8	25	6	4.9	4.2	.0045						
M 5	0.8	70	8	25	6	4.9	4.65	.0050	★	★		★	★	
M 6	1	80	10	30	6	4.9	5.6	.0060	★	★		★	★	
M 8	1.25	90	14	35	8	6.2	7.45	.0080	★	★		★	★	
M 10	1.5	100	16	39	10	8	9.35	.0100	★	★		★	★	









Reduced Shank

Nominal Size ø d ₁	P	mm					ø d ₂	□	Tool Identification					
		l ₁	l ₂	l ₃	Ø	□			Dimens. ID					
M 12	1.75	110	18	—	9	7	11.25	.0112						
M 14	2	110	20	—	11	9	13.1	.0114						
M 16	2	110	22	—	12	9	15.1	.0116						
M 18	2.5	125	25	—	14	11	16.85	.0118						
M 20	2.5	140	25	—	16	12	18.85	.0120						

1) Cold-forming in through holes is possible only with external cooling/lubrication
2) Restricted application possibilities with emulsion

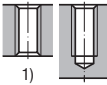
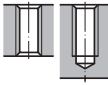
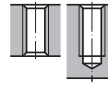

We recommend a smaller preparatory diameter by 0.05 mm for difficult to form materials (such as aluminum cast alloys) for P ≥ 1 mm.
For further information regarding the recommended preparatory diameters, see page 208 - 209.

GAL Aluminum Cast Alloys		H Materials of high tensile strength		Z CNC-Controlled Machines				
								
new	new			new	new			
6HX	6HX	6HX	6HX	6HX	6HX	Class of Fit		
TICN	TICN	TIN-T26	TIN-T26	TIN-80	TIN-80	Coating		
HSSE-PM	HSSE-PM	HSSE-PM	HSSE-PM	HSSE-PM	HSSE-PM	Cutting Material		
C / 2-3	E / 1.5-2	C / 2-3	C / 2-3	C / 2-3	C / 2-3	Technical Characteristics 		
E / O	E / O	E / O / P	E / O	E / O / P	E / O			
max. 3 x d ₁ 		max. 3 x d ₁ 		max. 3 x d ₁ 		Thread Depth and Hole Shape		
N 1.4-6	N 1.4-6	P 2.1-5.1 K 2.1	P 2.1-5.1 K 2.1	P 1.1-5.1 M 1.1-3.1 2) K 2.1 N 2.1-2, 2.4-5 S 1.1-2.2 2) S 2.4 2)	P 1.1-5.1 M 1.1-3.1 2) K 2.1 N 2.1-2, 2.4-5 S 1.1-2.2 2) S 2.4 2)	Applications – Material		
B523Q200	B531Q200	B521W700	B523W700	B521Z700	B523Z700	Tool Identification		
InnoForm 1-GAL-SN IKZ-PM-TICN	InnoForm 1-GAL/E-SN IKZ-PM-TICN	InnoForm 1-H-SN-PM TIN-T26	InnoForm 1-H-SN-IKZ PM-TIN-T26	InnoForm 1-Z-SN-PM TIN-80	InnoForm 1-Z-SN-IKZ PM-TIN-80	Dimens. ID	Nominal Size ø d ₁	P
						.0020	M 2	0.4
						.0025	M 2.5	0.45
				*		.0030	M 3	0.5
				*		.0035	M 3.5	0.6
				*	*	.0040	M 4	0.7
				*	*	.0045	M 4.5	0.75
*	*	*	*	*	*	.0050	M 5	0.8
*	*	*	*	*	*	.0060	M 6	1
*	*	*	*	*	*	.0080	M 8	1.25
*	*	*	*	*	*	.0100	M 10	1.5
		C521W700	C523W700	C521Z700	C523Z700	Tool Identification		
		InnoForm 2-H-SN-PM TIN-T26	InnoForm 2-H-SN-IKZ PM-TIN-T26	InnoForm 2-Z-SN-PM TIN-80	InnoForm 2-Z-SN-IKZ PM-TIN-80	Dimens. ID	Nominal Size ø d ₁	P
		*	*	*	*	.0112	M 12	1.75
		*	*	*	*	.0114	M 14	2
		*	*	*	*	.0116	M 16	2
		*	*	*	*	.0118	M 18	2.5
		*	*	*	*	.0120	M 20	2.5



- Product Finder
- V_c
- UNC
- UNF
- M
- MF
- G
- STI
- SELF-LOCK
- Tech. Info

DIN Length • DIN Shank

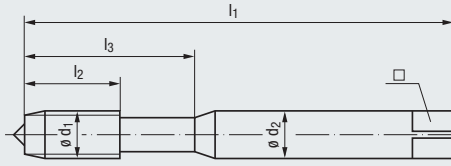

Reinforced Shank
(M2 - M10)

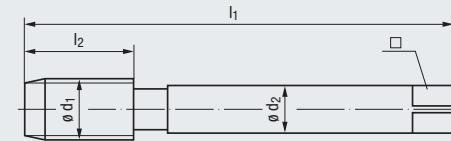

Reduced Shank
(M12 - M20)

M

**ISO Metric Coarse Thread
DIN 13**

Class of Fit
Coating
Cutting Material
Technical Characteristics

Thread Depth
and Hole Shape

Applications – Material

Z
CNC-Controlled
Machines

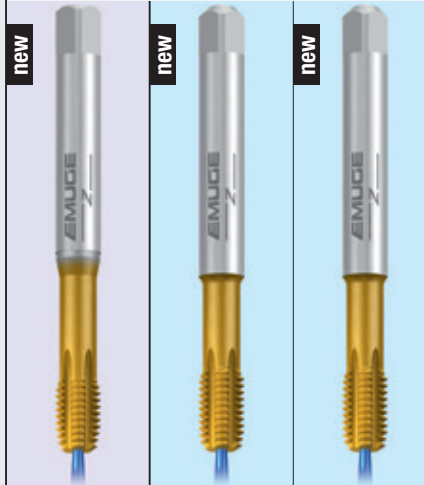

6HX	6HX	6HX
TIN-80	TIN-80	TIN-80
HSSE-PM	Carbide	Carbide
E / 1.5-2	C / 2-3	E / 1.5-2
E / 0	E / 0	E / 0

max. 3 x d₁

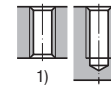

P 1.1-5.1	P 2.1-5.1	P 2.1-5.1
M 1.1-3.1²⁾	N 1.4-5, 2.4-5	N 1.4-5, 2.4-5
K 2.1		
N 2.1-2, 2.4-5		
S 1.1-2.2²⁾		
S 2.4²⁾		

Reinforced Shank

Nominal Size ø d ₁	P	mm					ø d ₂	□	Tool Identification
		l ₁	l ₂	l ₃	l ₃	l ₃			
M 2	0.4	45	4	12	2.8	2.1	1.85	.0020	
M 2.5	0.45	50	5	14	2.8	2.1	2.33	.0025	
M 3	0.5	56	6	18	3.5	2.7	2.8	.0030	
M 3.5	0.6	56	7	20	4	3	3.25	.0035	
M 4	0.7	63	7	21	4.5	3.4	3.7	.0040	
M 4.5	0.75	70	8	25	6	4.9	4.2	.0045	
M 5	0.8	70	8	25	6	4.9	4.65	.0050	
M 6	1	80	10	30	6	4.9	5.6	.0060	
M 8	1.25	90	14	35	8	6.2	7.45	.0080	
M 10	1.5	100	16	39	10	8	9.35	.0100	

Tool Identification		B531Z700	B523Z800	B531Z800
	Dimens. ID	InnoForm 1-Z/E-SN-IKZ PM-TIN-80	VHM InnoForm 1-Z-SN-IKZ TIN-80	VHM InnoForm 1-Z/E-SN-IKZ TIN-80
		*	*	*
		*	*	*
		*	*	*
		*	*	*

Reduced Shank

Nominal Size ø d ₁	P	mm					ø d ₂	□	Tool Identification
		l ₁	l ₂	l ₃	l ₃	l ₃			
M 12	1.75	110	18	—	9	7	11.25	.0112	
M 14	2	110	20	—	11	9	13.1	.0114	
M 16	2	110	22	—	12	9	15.1	.0116	
M 18	2.5	125	25	—	14	11	16.85	.0118	
M 20	2.5	140	25	—	16	12	18.85	.0120	

Tool Identification		C531Z700		
	Dimens. ID	InnoForm 2-Z/E-SN-IKZ PM-TIN-80		
		*		
		*		
		*		

¹⁾ Cold-forming in through holes is possible only with external cooling/lubrication
²⁾ Restricted application possibilities with emulsion



We recommend a smaller preparatory diameter by 0.05 mm for difficult to form materials (such as aluminum cast alloys) for P ≥ 1 mm.
 For further information regarding the recommended preparatory diameters, see page 208 - 209.

DIN Length • DIN Shank

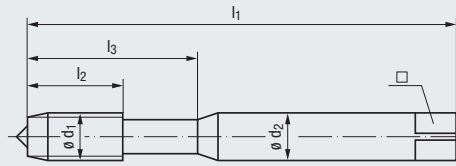

Reinforced Shank
(M2 - M10)

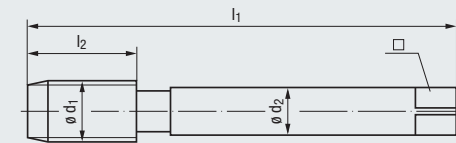

Reduced Shank
(M12 - M20)

SPEED
High-Speed
Cutting

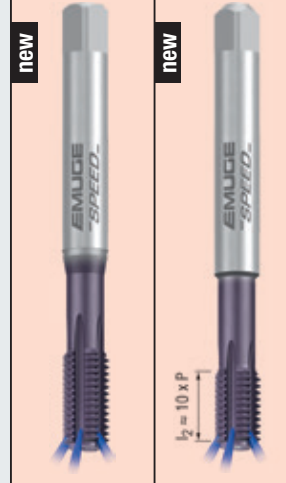

M

**ISO Metric Coarse Thread
DIN 13**

Class of Fit
Coating
Cutting Material
Technical Characteristics

6HX	6HX
TICN	TICN
HSS Extra	Carbide
E / 1.5-2	E / 1.5-2
E / 0	E / 0

Thread Depth
and Hole Shape

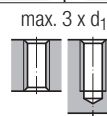

Applications – Material

N 1.4-5	N 1.4-5
----------------	----------------

Reinforced Shank

Nominal Size $\varnothing d_1$	P	l_1	mm			$\varnothing d_2$	\square	Tool Identification		B5059500	B505Q800
			l_2	l_3	$\varnothing d_2$			\square	Dimens. ID		
M 2	0.4	45	4	12	2.8	2.1	1.85	.0020			
M 2.5	0.45	50	5	14	2.8	2.1	2.33	.0025			
M 3	0.5	56	6	18	3.5	2.7	2.8	.0030			
M 3.5	0.6	56	7	20	4	3	3.25	.0035			
M 4	0.7	63	7	21	4.5	3.4	3.7	.0040			
M 4.5	0.75	70	8	25	6	4.9	4.2	.0045			
M 5	0.8	70	8	25	6	4.9	4.65	.0050			
M 6	1	80	10	30	6	4.9	5.6	.0060	*	*	
M 8	1.25	90	14	35	8	6.2	7.45	.0080	*	*	
M 10	1.5	100	16	39	10	8	9.35	.0100	*	*	

Reduced Shank

Nominal Size $\varnothing d_1$	P	l_1	mm			$\varnothing d_2$	\square	Tool Identification		C5059500	C505Q800
			l_2	l_3	$\varnothing d_2$			\square	Dimens. ID		
M 12	1.75	110	18	—	9	7	11.25	.0112		*	*
M 14	2	110	20	—	11	9	13.1	.0114			
M 16	2	110	22	—	12	9	15.1	.0116			
M 18	2.5	125	25	—	14	11	16.85	.0118			
M 20	2.5	140	25	—	16	12	18.85	.0120			

We recommend a smaller preparatory diameter by 0.05 mm for difficult to form materials (such as aluminum cast alloys) for $P \geq 1$ mm.
For further information regarding the recommended preparatory diameters, see page 208 - 209.

● = In stock
★ = Allow 7 days for delivery

- Product Finder
- V_c
- UNC
- UNF
- M
- MF
- G
- STI
- SELF-LOCK
- Tech. Info

ANSI Length • ANSI Shank

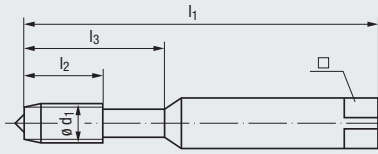

Reinforced Shank
(M4 - M10)

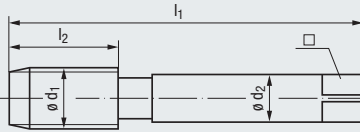

Reduced Shank
(M12 - M20)

STEEL
Steel
Materials



M

**ISO Metric Coarse Thread
DIN 13**

Class of Fit **6HX**
Coating **TIN**
Cutting Material **HSS Extra**
Technical Characteristics
 C / 2-3
 E / O / P

Thread Depth
and Hole Shape

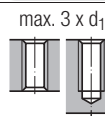

Applications – Material

- P 1.1-3.1**
- M 1.1-2.1²⁾**
- N 1.4-5, 2.1-2**

Tool Identification

AU921400

Nominal Size ϕd_1	P mm	l_1		inch				ϕd_2	\square		Dimens. ID mm	Druck STEEL-SN TIN
				l_2	l_3	ϕd_2	\square					
M 4	0.7	2 1/8	2.13	0.512	0.827	0.168	0.131	3.7	.0040			
M 5	0.8	2 3/8	2.38	0.591	0.945	0.194	0.152	4.65	.0050			
M 6	1	2 1/2	2.50	0.669	1.102	0.255	0.191	5.6	.0060	●		
M 8	1.25	2 23/32	2.72	0.787	1.299	0.318	0.238	7.45	.0080	●		
M 10	1.5	2 15/16	2.94	0.866	1.378	0.381	0.286	9.35	.0100	●		
M 12	1.75	3 3/8	3.38	0.984	—	0.367	0.275	11.25	.0112	●		
M 14	2	3 19/32	3.59	1.024	—	0.429	0.322	13.1	.0114			
M 16	2	3 13/16	3.81	1.063	—	0.480	0.360	15.1	.0116			
M 20	2.5	4 15/32	4.47	1.181	—	0.652	0.489	18.85	.0120			



We recommend a smaller preparatory diameter by 0.05 mm for difficult to form materials (such as aluminum cast alloys) for $P \geq 1$ mm. For further information regarding the recommended preparatory diameters, see page 208 - 209.

DIN Length • DIN Shank



All ANSI Length • ANSI Shank taps are available in the popular DIN Length • DIN Shank style.

The DIN Length • DIN Shank configuration allows for added reach capabilities and greater chip clearance.

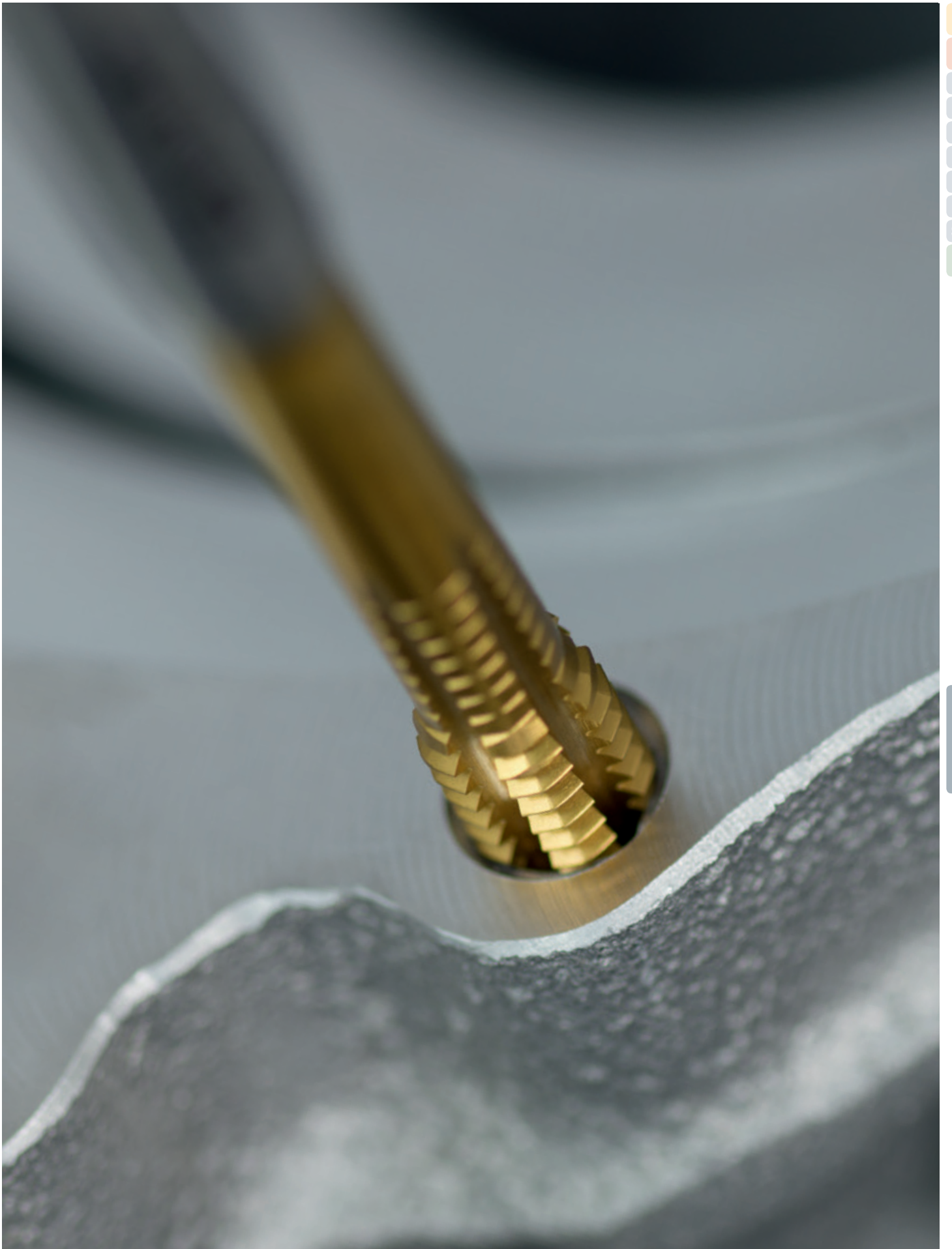

Product
Finder

V_c

UNC

UNF

M

MF

G

STI

SELF-LOCK

Tech. Info



- Product Finder
- V_c
- UNC
- UNF
- M
- MF**
- G
- STI
- SELF-LOCK
- Tech. Info

DIN Length • DIN Shank

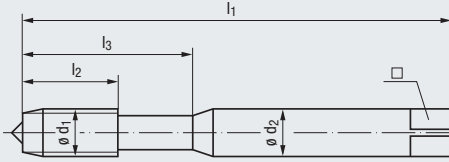

Reinforced Shank
(M3x0.35 - M10x1.25)

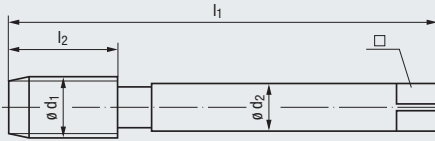

Reduced Shank
(M12x1.5 - M20x1.5)

MF



ISO Metric Fine Thread
DIN 13

Class of Fit

Coating

Cutting Material

Technical Characteristics



Thread Depth
and Hole Shape

Applications – Material

STEEL
Steel
Materials



6HX	6HX	6HX	6HX	6HX
TIN	TIN	TIN-66	TIN-66	TIN-66
HSS Extra	HSS Extra	HSSE-PM	HSSE-PM	HSSE-PM
C / 2-3	C / 2-3	C / 2-3	C / 2-3	E / 1.5-2
E / O / P	E / O / P	E / O / P	E / O	E / O

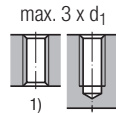
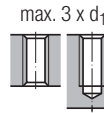

P 1.1-3.1	P 1.1-3.1	P 1.1-4.1	P 1.1-4.1	P 1.1-4.1
M 1.1-2.1²⁾	M 1.1-2.1²⁾	K 2.1	K 2.1	K 2.1
N 1.4-5, 2.1-2	N 1.4-5, 2.1-2			

Reinforced Shank

Nominal Size ø d ₁	P	mm						□	Tool Identification
		l ₁	l ₂	l ₃	ø d ₂	□	□		
M 3 x 0.35		56	8	18	3.5	2.7		2.88	
M 4 x 0.5		63	10	21	4.5	3.4		3.8	
M 5 x 0.5		70	11	25	6	4.9		4.8	
M 6 x 0.75		80	13	30	6	4.9		5.7	
M 8 x 0.75		80	14	30	8	6.2		7.7	
M 8 x 1		90	17	35	8	6.2		7.6	
M 10 x 1		90	18	35	10	8		9.6	
M 10 x 1.25		100	18	39	10	8		9.45	

Tool Identification		B0911400	B0921400			
Image	Dimens. ID	Druck 1-STEEL TIN	Druck 1-STEEL-SN TIN			
		★	★			
		★	★			
		★	★			
		★	★			
		★	★			
		★	★			
		★	★			

Reduced Shank







Nominal Size ø d ₁	P	mm						□	Tool Identification
		l ₁	l ₂	l ₃	ø d ₂	□	□		
M 12 x 1.25		100	22	—	9	7		11.45	
M 12 x 1.5		100	22	—	9	7		11.35	
M 14 x 1.25		100	22	—	11	9		13.45	
M 14 x 1.5		100	22	—	11	9		13.35	
M 16 x 1.5		100	22	—	12	9		15.35	
M 18 x 1.5		110	25	—	14	11		17.35	
M 20 x 1.5		125	25	—	16	12		19.35	

Tool Identification		C0911400	C0921400	C5217F00	C5237F00	C5317F00
Image	Dimens. ID	Druck 2-STEEL TIN	Druck 2-STEEL-SN TIN	InnoForm 2-STEEL-M SN-PM TIN-66	InnoForm 2-STEEL-M SN-IKZ-PM TIN-66	InnoForm 2-STEEL-M/E SN-IKZ-PM TIN-66
		★	★	★	★	★
		★	★	★	★	★
		★	★	★	★	★
		★	★	★	★	★
		★	★			

- 1) Cold-forming in through holes is possible only with external cooling/lubrication
- 2) Restricted application possibilities with emulsion
- 3) Patent pending



We recommend a smaller preparatory diameter by 0.05 mm for difficult to form materials (such as aluminum cast alloys) for P ≥ 1 mm.
For further information regarding the recommended preparatory diameters, see page 208 - 209.

STEEL Steel Materials		Z CNC-Controlled Machines		SPEED High-Speed Cutting				
								
6HX TICN-67 HSSE-PM C / 2-3 E / O / P	6HX TICN-67 HSSE-PM C / 2-3 E / O	6HX TIN-80 HSSE-PM C / 2-3 E / O / P	6HX TIN-80 HSSE-PM C / 2-3 E / O	6HX TICN HSS Extra E / 1.5-2 E / O	6HX TICN Carbide E / 1.5-2 E / O	Class of Fit Coating Cutting Material Technical Characteristics		
max. 3 x d ₁	max. 3 x d ₁	max. 3 x d ₁	max. 3 x d ₁	max. 3 x d ₁		Thread Depth and Hole Shape		
P 3.1-5.1 K 2.1	P 3.1-5.1 K 2.1	P 1.1-5.1 M 1.1-3.1²⁾ K 2.1 N 2.1-2, 2.4-5 S 1.1-2.2²⁾ S 2.4²⁾	P 1.1-5.1 M 1.1-3.1²⁾ K 2.1 N 2.1-2, 2.4-5 S 1.1-2.2²⁾ S 2.4²⁾	N 1.4-5 N 1.4-5		Applications – Material		
		B521Z700	B523Z700	B5059500	B505Q800	Tool Identification		
		InnoForm 1-Z-SN-PM TIN-80	InnoForm 1-Z-SN- IKZ PM-TIN-80	Druck 1-GAL SPEED/E-SN IKZN-TICN	VHM-Druck 1-GAL SPEED/E-SN IKZN-TICN	Dimens. ID	Nominal Size ø d ₁	P
						.0202	M 3 x	0.35
						.0210	M 4 x	0.5
						.0218	M 5 x	0.5
						.0229	M 6 x	0.75
						.0250	M 8 x	0.75
		★	★	★	★	.0251	M 8 x	1
		★	★	★	★	.0276	M 10 x	1
				★	★	.0277	M 10 x	1.25
C5216F00	C5236F00	C521Z700	C523Z700	C5059500	C505Q800	Tool Identification		
InnoForm 2-STEEL-H SN-PM TICN-67	InnoForm 2-STEEL-H SN- IKZ -PM TICN-67	InnoForm 2-Z-SN-PM TIN-80	InnoForm 2-Z-SN- IKZ PM-TIN-80	Druck 2-GAL SPEED/E-SN IKZN-TICN	VHM-Druck 2-GAL SPEED/E-SN IKZN-TICN	Dimens. ID	Nominal Size ø d ₁	P
						.0302	M 12 x	1.25
★	★			★	★	.0303	M 12 x	1.5
						.0330	M 14 x	1.25
★	★			★	★	.0331	M 14 x	1.5
★	★			★	★	.0359	M 16 x	1.5
						.0390	M 18 x	1.5
						.0422	M 20 x	1.5



- Product Finder
- V_c
- UNC
- UNF
- M
- MF
- G**
- STI
- SELF-LOCK
- Tech. Info

DIN Length • DIN Shank

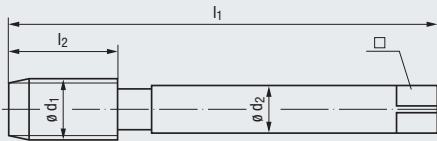

Reduced Shank

STEEL Steel Materials



Z CNC-Controlled Machines

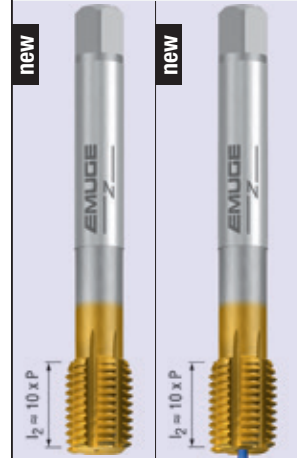

G

**Whitworth Pipe Thread
DIN EN ISO 228**

Class of Fit: "X"
Coating: TIN
Cutting Material: HSS Extra
Technical Characteristics: C / 2-3, E / O / P

Thread Depth and Hole Shape

Applications – Material

Class of Fit: "X"
Coating: TIN
Cutting Material: HSS Extra
Technical Characteristics: C / 2-3, E / O / P

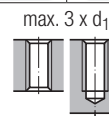

Applications – Material: P 1.1-3.1, M 1.1-2.1²⁾, N 1.4-5, 2.1-2

Class of Fit: "X"
Coating: TIN-80
Cutting Material: HSSE-PM
Technical Characteristics: C / 2-3, E / O / P

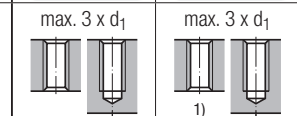

Applications – Material: P 1.1-5.1, M 1.1-3.1²⁾, K 2.1, N 2.1-2, 2.4-5, S 1.1-2.2²⁾, S 2.4²⁾

Reduced Shank

Nominal Size ø d ₁	T.P.I.	ø d ₁	l ₁	mm		ø d ₂	□	Tool Identification		C0911400	C0921400	C521Z700	C523Z700
				l ₂	l ₂			Dimens. ID	Dimens. ID				
G 1/16	7.72	28	90	17	6	4.9	7.25	.4034					
G 1/8	9.73	28	90	18	7	5.5	9.25	.4035	★	★		★	★
G 1/4	13.16	19	100	22	11	9	12.55	.4036	★	★		★	★
G 3/8	16.66	19	100	22	12	9	16.05	.4037	★	★		★	★
G 1/2	20.96	14	125	25	16	12	20.1	.4038	★	★		★	★
G 5/8	22.91	14	125	25	18	14.5	22.05	.4039					
G 3/4	26.44	14	140	28	20	16	25.6	.4040					
G 7/8	30.20	14	150	28	22	18	29.35	.4041					
G 1	33.25	11	160	30	25	20	32.15	.4042					

1) Cold-forming in through holes is possible only with external cooling/lubrication
2) Restricted application possibilities with emulsion



We recommend a smaller preparatory diameter by 0.002 in for difficult to form materials (such as aluminum cast alloys) for P = 24 T.P.I. and coarser threads. For further information regarding the recommended preparatory diameters, see page 208 - 209.

DIN Length - ANSI Shank

Overall length acc. to DIN 2174

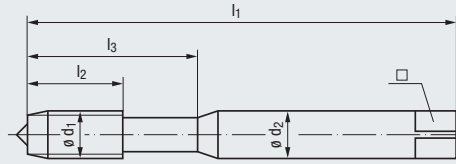

Reinforced Shank
(STI-No.2 - STI 5/16)

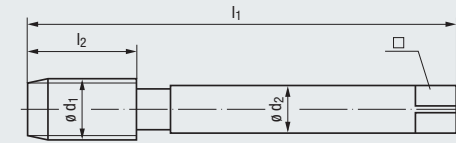

Reduced Shank
(STI 3/8 - STI 1/2)

STEEL
Steel
Materials

new



STI-UNC

Unified Coarse Thread
ASME B18.29.1

For wire thread inserts

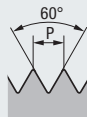

Class of Fit
Coating
Cutting Material
Technical Characteristics



Thread Depth
and Hole Shape

- 2BX
- TICN
- HSS Extra
- C / 2-3
- E / O / P

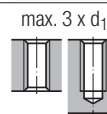

Applications - Material

- P 1.1-3.1
- M 1.1-2.1²⁾
- N 1.4-5, 2.1-2

Reinforced Shank

Tool Identification

BU929000

Nominal Size ø d ₁	T.P.I.	inch						□
		ø d ₁	l ₁	l ₂	l ₃	ø d ₂	□	



Dimens. ID

Druck
1-STEEL-SN
TICN

STI-No. 2	56	0.1092	2.205	0.433	0.709	0.141	0.110	0.1004	.5609	●				
STI-No. 4	40	0.1445	2.205	0.472	0.787	0.141	0.110	0.1327	.5611	●				
STI-No. 6	32	0.1786	2.756	0.512	0.984	0.194	0.152	0.1634	.5613	●				
STI-No. 8	32	0.2046	3.150	0.512	1.142	0.220	0.165	0.1909	.5614	●				
STI-No. 10	24	0.2441	3.150	0.669	1.181	0.255	0.191	0.2244	.5615	●				
STI 1/4	20	0.3150	3.543	0.787	1.378	0.318	0.238	0.2913	.5617	●				
STI 5/16	18	0.3847	3.937	0.866	1.535	0.381	0.286	0.3583	.5618	●				

Reduced Shank

Tool Identification

CU929000

Nominal Size ø d ₁	T.P.I.	inch						□
		ø d ₁	l ₁	l ₂	l ₃	ø d ₂	□	



Dimens. ID

Druck
2-STEEL-SN
TICN

STI 3/8	16	0.4562	3.937	0.866	—	0.367	0.275	0.4272	.5619	●				
STI 7/16	14	0.5303	4.331	1.024	—	0.429	0.322	0.4961	.5620	●				
STI 1/2	13	0.5999	4.331	1.063	—	0.480	0.360	0.5630	.5621	●				



We recommend a smaller preparatory diameter by 0.002 in for difficult to form materials (such as aluminum cast alloys) for P = 24 T.P.I. and coarser threads. For further information regarding the recommended preparatory diameters, see page 208 - 209.



- Product Finder
- V_c
- UNC
- UNF
- M
- MF
- G
- STI
- SELF-LOCK
- Tech. Info

DIN Length - ANSI Shank

Overall length acc. to DIN 2174

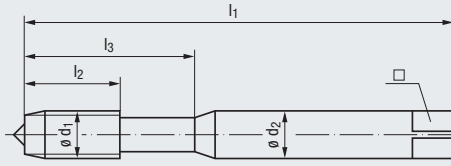

Reinforced Shank
(STI-No.4 - STI 5/16)

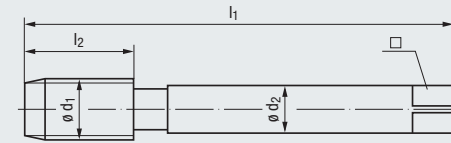

Reduced Shank
(STI 3/8 - STI 1/2)

new

STI-UNF



Unified Fine Thread
ASME B18.29.1

For wire thread inserts

- Class of Fit: 2BX
- Coating: TiCN
- Cutting Material: HSS Extra
- Technical Characteristics: C / 2-3, E / O / P
- Thread Depth and Hole Shape: max. 3 x d₁

- 2BX
- TiCN
- HSS Extra
- C / 2-3
- E / O / P



Applications – Material

- P 1.1-3.1
- M 1.1-2.1²⁾
- N 1.4-5, 2.1-2

Reinforced Shank

Nominal Size ø d ₁	T.P.I.	inch						
		ø d ₁	l ₁	l ₂	l ₃	ø d ₂	□	
STI-No. 4	48	0.1391	2.205	0.472	0.787	0.141	0.110	0.1299
STI-No. 6	40	0.1705	2.480	0.512	0.827	0.168	0.131	0.1594
STI-No. 8	36	0.2001	3.150	0.512	1.142	0.220	0.165	0.1870
STI-No. 10	32	0.2306	3.150	0.512	1.181	0.255	0.191	0.2165
STI 1/4	28	0.2964	3.543	0.669	1.260	0.318	0.238	0.2795
STI 5/16	24	0.3666	3.937	0.709	1.535	0.381	0.286	0.3465

Tool Identification		BU929000
Dimens. ID	Druck	1-STEEL-SN TiCN
.5633	●	
.5635	●	
.5636	●	
.5637	●	
.5639	●	
.5640	●	

Reduced Shank

Nominal Size ø d ₁	T.P.I.	inch						
		ø d ₁	l ₁	l ₂	l ₃	ø d ₂	□	
STI 3/8	24	0.4291	3.937	0.709	—	0.323	0.242	0.4094
STI 7/16	20	0.5025	3.937	0.866	—	0.367	0.275	0.4783
STI 1/2	20	0.5650	3.937	0.866	—	0.429	0.322	0.5413

Tool Identification		CU929000
Dimens. ID	Druck	2-STEEL-SN TiCN
.5641	●	
.5642	●	
.5643	●	



We recommend a smaller preparatory diameter by 0.002 in for difficult to form materials (such as aluminum cast alloys) for P = 24 T.P.I. and coarser threads. For further information regarding the recommended preparatory diameters, see page 208 - 209.

DIN Length • ANSI Shank

Overall length acc. to DIN 2174

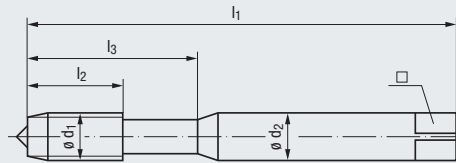

Reinforced Shank
(LK No.4 - LK 3/8)

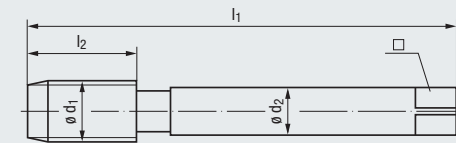

Reduced Shank
(LK 7/16 - LK 1/2)

STEEL
Steel
Materials

new



Product
Finder

Vc

UNC

UNF

M

MF

G

STI

SELF-LOCK

Tech. Info

LK-UNC

Unified SELF-LOCK Coarse Thread
EMUGE Standard

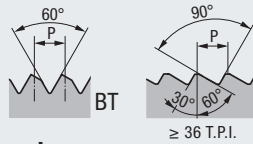

Type
Coating
Cutting Material
Technical Characteristics

BT

TIN

HSS Extra

E / 1.5-2

E / O / P

Thread Depth
and Hole Shape

max. 3 x d₁



Applications – Material

P 1.1-3.1

M 1.1-2.1 2)

N 1.4-5, 2.1-2

Reinforced Shank

Tool Identification

BU931400

Nominal Size ø d ₁	T.P.I.	l ₁	l ₂	inch l ₃	ø d ₂	□	Tool ID	Dimens. ID	Material
LK No. 4	40	2.205	0.433	0.709	0.141	0.110	0.1043	.5656	●
LK No. 6	32	2.205	0.472	0.787	0.141	0.110	0.1280	.5658	●
LK No. 8	32	2.480	0.512	0.827	0.168	0.131	0.1555	.5659	●
LK No. 10	24	2.756	0.591	0.984	0.194	0.152	0.1772	.5660	●
LK No. 12	24	3.150	0.630	1.142	0.220	0.165	0.2028	.5661	●
LK 1/4	20	3.150	0.669	1.181	0.255	0.191	0.2323	.5662	●
LK 5/16	18	3.543	0.787	1.378	0.318	0.238	0.2933	.5663	●
LK 3/8	16	3.937	0.866	1.535	0.381	0.286	0.3524	.5664	●



Druck
1-STEEL/E-SN
TIN



Reduced Shank

Tool Identification

CU931400

Nominal Size ø d ₁	T.P.I.	l ₁	l ₂	inch l ₃	ø d ₂	□	Tool ID	Dimens. ID	Material
LK 7/16	14	3.937	0.866	—	0.323	0.242	0.4094	.5665	●
LK 1/2	13	4.331	0.984	—	0.367	0.275	0.4724	.5666	●



Druck
2-STEEL/E-SN
TIN

We recommend a smaller preparatory diameter by 0.002 in for difficult to form materials (such as aluminum cast alloys) for P = 24 T.P.I. and coarser threads. For further information regarding the recommended preparatory diameters, see page 208 - 209.

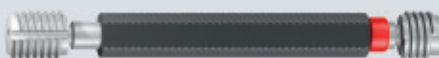

Gages for Unified SELF-LOCK coarse thread, see page 455

- Product Finder
- V_c
- UNC
- UNF
- M
- MF
- G
- STI
- SELF-LOCK
- Tech. Info

DIN Length - ANSI Shank

Overall length acc. to DIN 2174

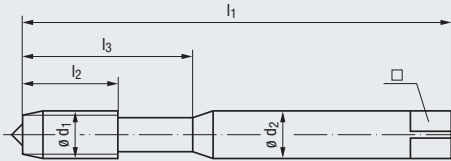

Reinforced Shank
(LK No.4 - LK 3/8)

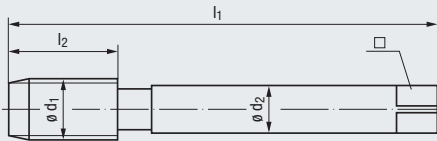

Reduced Shank
(LK 7/16 - LK 1/2)

STEEL
Steel
Materials

new



LK-UNF

Unified SELF-LOCK Fine Thread
EMUGE Standard

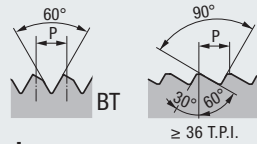

Type
Coating
Cutting Material
Technical Characteristics

- BT
- TIN
- HSS Extra
- E / 1.5-2
- E / 0 / P

Thread Depth
and Hole Shape

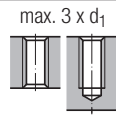

Applications - Material

- P 1.1-3.1
- M 1.1-2.1²⁾
- N 1.4-5, 2.1-2

Reinforced Shank

Nominal Size ø d ₁	T.P.I.	l ₁	l ₂	inch			ø d ₂	□	Tool Identification	
				l ₃					Dimens. ID	BU931400
LK No. 4	48	2.205	0.433	0.709	0.141	0.110	0.1055	.5707	Druck 1-STEEL/E-SN TIN	
LK No. 6	40	2.205	0.472	0.787	0.141	0.110	0.1299	.5709	●	
LK No. 8	36	2.480	0.512	0.827	0.168	0.131	0.1555	.5710	●	
LK No. 10	32	2.756	0.512	0.984	0.194	0.152	0.1811	.5711	●	
LK 1/4	28	3.150	0.669	1.181	0.255	0.191	0.2382	.5713	●	
LK 5/16	24	3.543	0.669	1.260	0.318	0.238	0.2992	.5714	●	
LK 3/8	24	3.937	0.709	1.535	0.381	0.286	0.3622	.5715	●	

Reduced Shank

Nominal Size ø d ₁	T.P.I.	l ₁	l ₂	inch			ø d ₂	□	Tool Identification	
				l ₃					Dimens. ID	CU931400
LK 7/16	20	3.937	0.866	—	0.323	0.242	0.4213	.5716	Druck 2-STEEL/E-SN TIN	
LK 1/2	20	3.937	0.866	—	0.367	0.275	0.4843	.5717	●	



We recommend a smaller preparatory diameter by 0.002 in for difficult to form materials (such as aluminum cast alloys) for P = 24 T.P.I. and coarser threads. For further information regarding the recommended preparatory diameters, see page 208 - 209.

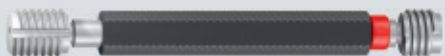

Gages for Unified SELF-LOCK fine thread, see page 456

DIN Length • DIN Shank

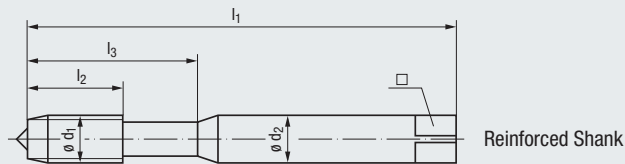

STEEL
Steel
Materials



- Product Finder
- Vc
- UNC
- UNF
- M
- MF
- G
- STI
- SELF-LOCK**
- Tech. Info

<h1>LK-M</h1> <p>Metric SELF-LOCK Coarse Thread EMUGE Standard</p>	Type	BT	BT
	Coating	TIN	TIN
Cutting Material Technical Characteristics	HSS Extra	HSS Extra	
		C / 2-3	C / 2-3
Thread Depth and Hole Shape		max. 3 x d ₁	
Applications – Material	P 1.1-3.1 M 1.1-2.1 ²⁾ N 1.4-5, 2.1-2	P 1.1-3.1 M 1.1-2.1 ²⁾ N 1.4-5, 2.1-2	

Reinforced Shank								Tool Identification		B0911400	B0921400
Nominal Size ø d ₁	P	l ₁	mm			ø d ₂	□		Dimens. ID	Druck	Druck
			l ₂	l ₃	1-STEEL					1-STEEL-SN	
LK-M 3	0.5	56	11	18	3.5	2.7	2.85	.1046	★	★	
LK-M 4	0.7	63	13	21	4.5	3.4	3.8	.1048	★	★	
LK-M 5	0.8	70	15	25	6	4.9	4.8	.1050	★	★	
LK-M 6	1	80	17	30	6	4.9	5.7	.1052	★	★	
LK-M 8	1.25	90	20	35	8	6.2	7.6	.1054	★	★	
LK-M 10	1.5	100	22	39	10	8	9.5	.1056	★	★	

²⁾ Restricted application possibilities with emulsion

The alternative in locking thread technology and thread stripping prevention.

- Self-locking internal thread form
- For standard external fasteners
- Eliminates need for costly and ineffective inserts or locking parts
- Ease of assembly
- Provides uniform distribution of load over the entire thread length
- Reduces probability of thread stripping in aluminum and other soft materials

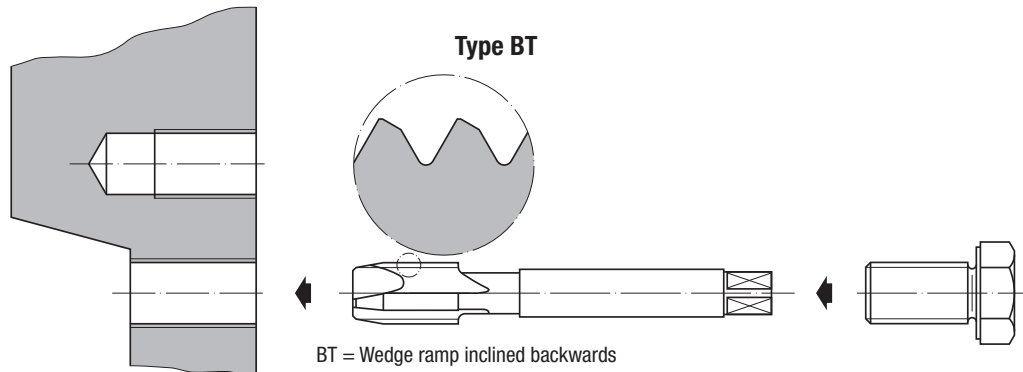

We recommend a smaller preparatory diameter by 0.05 mm for difficult to form materials (such as aluminum cast alloys) for P ≥ 1 mm. For further information regarding the recommended preparatory diameters, see page 208 - 209.

- Product Finder
- V_c
- UNC
- UNF
- M
- MF
- G
- STI
- SELF-LOCK
- Tech. Info



Leading Solutions for Chamfered / Threaded Holes

Technical Information

		Page
2.1	General technical information regarding EMUGE threading tools	200
2.2	Dimensions and technical sales conditions	200
2.3	Constructional designs of our EMUGE roll form taps	200
2.4	Special roll form tap types (examples)	201
2.5	Basic types of our EMUGE roll form taps	201
2.6	Our EMUGE geometries	202
2.7	Our EMUGE surface treatments and coatings	202
2.8	Other EMUGE abbreviations	203
2.9	Lead taper forms	203
2.10	Cooling and lubrication agents	203
2.11	Tolerance zones of the pitch diameter on the Unified thread (graphic representation)	204
2.12	Tolerance zones of the pitch diameter on the Metric thread (graphic representation)	204
2.13	Cold forming and torque	205
2.14	Cold forming as a production process	205
2.15	The difference between a cut thread and a cold-formed thread	206
2.16	Thread hole preparatory diameter for roll form taps	207
2.17	Recommended tap drill sizes for cold-forming internal threads	208 - 209

Product
FinderV_c

UNC

UNF

M

MF

G

STI

SELF-LOCK

Tech. Info



- Product Finder
- V_c
- UNC
- UNF
- M
- MF
- G
- STI
- SELF-LOCK
- Tech. Info**

2.1 General technical information regarding EMUGE threading tools

EMUGE threading tools are made exclusively of high-performance high-speed steels according to EMUGE specifications. Our modified tool steels are based on the material alloy group HSSE acc. DIN ISO 11054.

As for tools which are designed for a special application, these generally used tool materials do not come up to our requirements. In such cases we use special high-speed steel alloys and carbide materials which are specially selected for the work case in question. A rigorous quality control of these materials forms the basis of our high-quality tools. Research and development work is carried out in a specially equipped laboratory, and serves as an indispensable precondition for the further development of cutting geometries and other parameters necessary for thread production. Extensive tests and trials on CNC machines, conventional drilling and thread cutting machines guarantee the performance and economic efficiency of our tools.

2.2 Dimensions and technical sales conditions

The dimensional specifications of our threading tools are adjusted to the currently valid standards, with the exception of special tools made to EMUGE standards.

The DIN standards for taps are based on the General Plans of Dimensions for Taps acc. DIN 2184-1 and -2.



Please read the notes in this catalog and in the technical introduction carefully.

The technical sales conditions for taps acc. DIN 2197 and roll form taps acc. DIN 2175 have been taken into account.

The manufacturing tolerances for the thread part are in accordance with DIN EN 22857 and DIN 802.

All specifications, illustrations and dimensions are subject to change due to technical progress and possible changes of the standards, and are consequently without obligation.

2.3 Constructional designs of our EMUGE roll form taps

	Constructional design	EMUGE designation
	Short machine roll form taps	Druck
	Machine roll form taps with reinforced shank	Druck 1 InnoForm 1
	Machine roll form taps with reduced shank	Druck 2 InnoForm 2

Geometric construction of a roll form tap

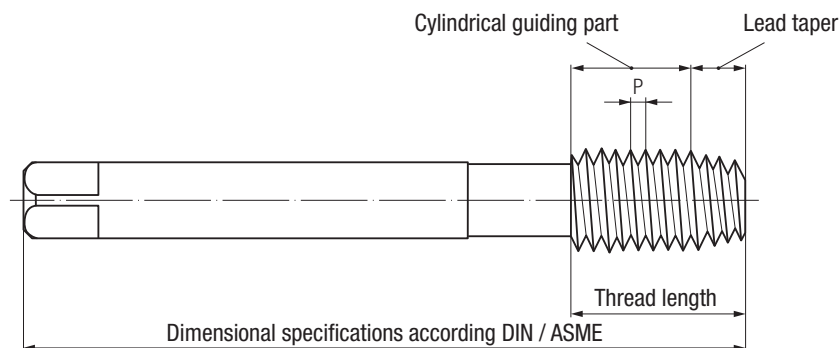
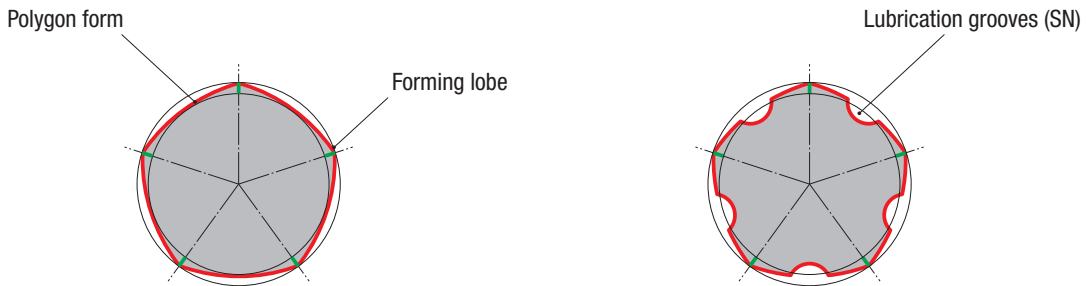

2.4 Special roll form tap types (examples)

Special taps to customers' specifications

EMUGE produces special roll form taps to customers' drawings and proper specifications.

InnoForm special tools

If our comprehensive InnoForm program of roll form taps does not include a suitable tool design for a specific application, we will be happy to furnish a custom-made, special InnoForm tool designed for the work conditions and according to the workpiece drawing of the individual customer. Such special designs can be made in special thread sizes and tolerances, with special thread profiles and dimensional specifications, or for special processes involving combined thread cutting and cold forming.

Special threads (examples)

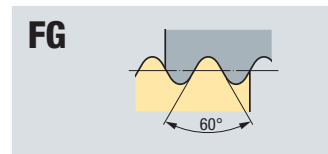

FG
Bicycle thread
acc. DIN 79012

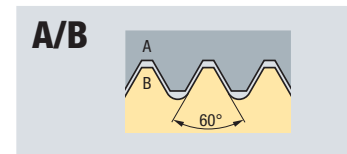

A/B
Tripod connection thread
acc. DIN 4503

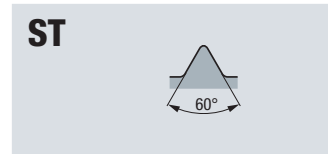

ST
Sheet metal screw thread
acc. DIN EN ISO 1478

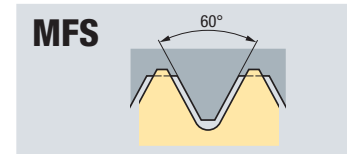

MFS
ISO Metric thread for tight fit
acc. DIN 8141-1

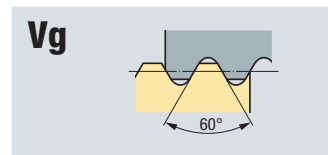

Vg
Valve thread
acc. DIN 7756

2.5 Basic types of our EMUGE roll form taps

EMUGE is the first threading tool manufacturer worldwide to introduce a program of roll form taps specially designed for the machining of specific materials or material groups. While this was possible only for cutting tools, we have succeeded in designing roll form taps especially for the special properties of single materials and material groups, sometimes increasing performance in a dramatic way.

Until then conventional roll form taps were made for the use in all ductile materials: potential performance features in defined applications were simply wasted in the process.

EMUGE has made extensive investigations into the mechanisms of cold forming for years, and developed an entirely new tool generation from the results. In order to highlight the uniqueness of this highly innovative program of roll form taps, we have thought of a new name: **InnoForm**

Druck



- Roll form tap for the chipless production of internal threads
- Lead taper form E (1.5-2 threads)
- Lead taper form C (2-3 threads)
- Lead taper form D (4-5 threads)
- For blind hole and through hole threads

Note:

Depending on the workpiece material, the essential advantages of the cold-forming of threads are not only excellent surface quality but also higher static and dynamic strength of the thread.

The length of the thread to be produced is not limited by chips which must be removed. The tools feature an excellent stability, especially with small thread sizes. All ductile materials can be cold-formed. Sufficient lubrication is essential. We generally recommend using oil grooves for through hole threads and horizontal machining. (Exception: very short through hole threads, e.g. sheet metal components).

InnoForm

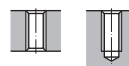

Sometimes, it is necessary to adjust the recommended thread hole preparatory diameter to work conditions.

Product Finder

Vc

UNC

UNF

M

MF

G

ST

SELF-LOCK

Tech. Info



2.6 Our EMUGE geometries

EMUGE
STEEL

Druck
InnoForm

For steel materials

This highly successful geometry has been designed for general use in steel. It is available ex stock in numerous thread systems and sizes. Circumference speeds can be increased by combining it with a suitable hard surface coating.

- InnoForm STEEL-M – For medium strength steels
- InnoForm STEEL-H – For high strength steels

EMUGE
AL

InnoForm

For aluminum wrought alloys

Under the usual lubrication conditions, e.g. emulsion lubrication, these materials show a strong inclination to adhesion in the cold forming of threads. In order to obtain satisfactory work results in spite of these unfavourable material properties, this geometry was provided with a coating that offers excellent friction characteristics and, as a result, a perfect degree of process safety.

EMUGE
H

InnoForm

For materials of high tensile strength

This geometry was designed for the cold forming of materials with restricted ductile properties. The special tool geometry, combined with an appropriate hard surface coating, provides excellent quality of the finished threads and very good wear resistance.

EMUGE
SPEED

Druck
InnoForm

For high-speed tapping

CNC machines, especially in combination with the collet holders of our Speedsynchro® Modular series, make very high speeds possible.

The special geometry of these tools, combined with a hard surface coating, offers you the chance to do your machining at the highest speeds your machine can manage.

EMUGE
VA

InnoForm

For stainless steel materials and steel materials

These materials show a high degree of adhesion which can lead to cold-welding effects. Also, they tend to strengthening during the forming process which puts more stress on the forming lobes.

In order to compensate this, we have developed a geometry which meets the elevated requirements towards stability perfectly.

EMUGE
GAL

Druck
InnoForm

For aluminum cast alloys

Cast aluminum materials exert a very strong abrasive stress on the forming lobes of a roll form tap during work. In addition, the ductile properties of these rather brittle materials must be regarded as relatively poor. In order to achieve easier thread production and better wear resistance even under these bad conditions, we have given this tool type a specially adjusted geometry and an additional hard surface coating.

EMUGE
Z

Druck
InnoForm

For CNC-controlled machines

This geometry is aimed at reducing the unavoidable friction forces and the heat stress on the forming lobes especially for use on CNC-controlled machines. With a synchronous feed control, the performance potential of these tools can be used to the full, especially in combination with the collet holders of our Softsynchro® series.



2.7 Our EMUGE surface treatments and coatings

NT



Nitriding

In a thermo-chemical treatment, the surface is enriched with nitrogen to a depth of approx. 0.03 to 0.05 mm. Since the surface becomes very hard (1000-1250 HV), nitrided tools are a very good choice for abrasive materials like cast iron, spheroidal cast iron, cast aluminum and duroplastics. Tool life is increased in a decisive manner.

TIN

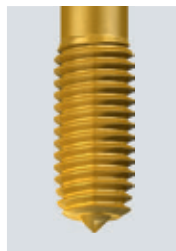

Titanium nitride (gold-yellow)

In a PVD process (500 °C) a coating thickness of 3-7 µm can be realized. The smooth coatings feature a high adhesion strength and TIN-typical properties against cold welding.

TIN coating systems with additional code number (e.g. TIN-66, TIN-80) are optimized with regard to substrate, tool geometry and application.

TICN



Titanium carbonitride (blue-grey)

In a PVD process (500 °C) a coating thickness of 2-4 µm can be realized. The hardness is approx. 3000 HV. The TICN coating will resist up to approx. 400 °C.

TICN coating systems with additional code number (e.g. TICN-67) are optimized with regard to substrate and application.

GLT-8



Diamond-like, amorphous carbon coating (black-grey)

In a PVD process a coating thickness of 1-2 µm can be realized. The hardness is approx. 2500 HV. This mono-layer coating is an excellent choice for the machining of non-ferrous metals and aluminum with a low silicon content (< 7% Si). Thanks to the low friction, material adhesion is drastically reduced. This coating will remain resistant up to approx. 350 °C.

2.8 Other EMUGE abbreviations

IKZ



**Internal coolant supply, axial
(DIN designation: KA)**

The axial exit of coolant-lubricant provides optimum cooling and lubrication in the lead taper area.

IKZN



**Internal coolant supply, axial,
with coolant exiting in the flutes
(DIN designation: KR)**

Radial exit of coolant-lubricant is the safest solution for providing coolant supply in the lead taper area even in through holes.

VHM

Solid carbide

Tools with a thread diameter < 12.0 mm are made of solid carbide (thread part and shank).

2.9 Lead taper forms

Lead taper forms and lead taper lengths for roll form taps acc. DIN 2175.

Form C

Lead taper length 2-3 threads

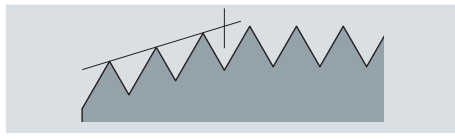

Form D

Lead taper length 3-5.5 threads

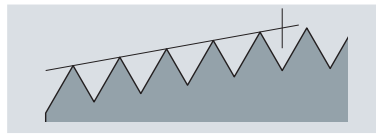

Form E

Lead taper length 1.5-2 threads

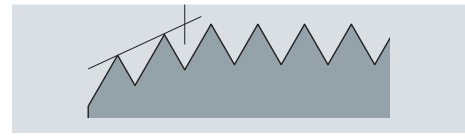

The chamfer length of our EMUGE taps is adjusted to the workpiece material in each individual case.

2.10 Cooling and lubrication agents

Lubricants are often, if not generally, given too little consideration. If you want to get the best performance out of your tool you have to take care to use the best coolant-lubricant available.

In general, we distinguish the following types of cooling and lubrication:

A

Dry machining, pressurized air, cold pressurized air

"Real" dry machining is mostly used only in cast iron. Pressurized air, sometimes cooled, is used in some cases for chip removal.

E

Emulsion

The most common type of coolant-lubricant on machining centres.

O

Thread cutting oil

With these oils which are perfectly adjusted to specific materials, excellent thread surfaces and tool life can be achieved.



M

Minimum-quantity lubrication (MQL)

Due to the more and more common option of supplying aerosol through the spindle on modern machining centres, this type of cooling and lubrication is gaining more and more popularity.

P

Thread cutting paste

Perfectly suitable for the cold forming of threads. Especially useful in horizontal machining, with large thread sizes and through hole threads. To be used only for brush lubrication.



- Product Finder
- V_c
- UNC
- UNF
- M
- MF
- G
- STI
- SELF-LOCK
- Tech. Info

2.11 Tolerance zones of the pitch diameter on the Unified thread (graphic representation)

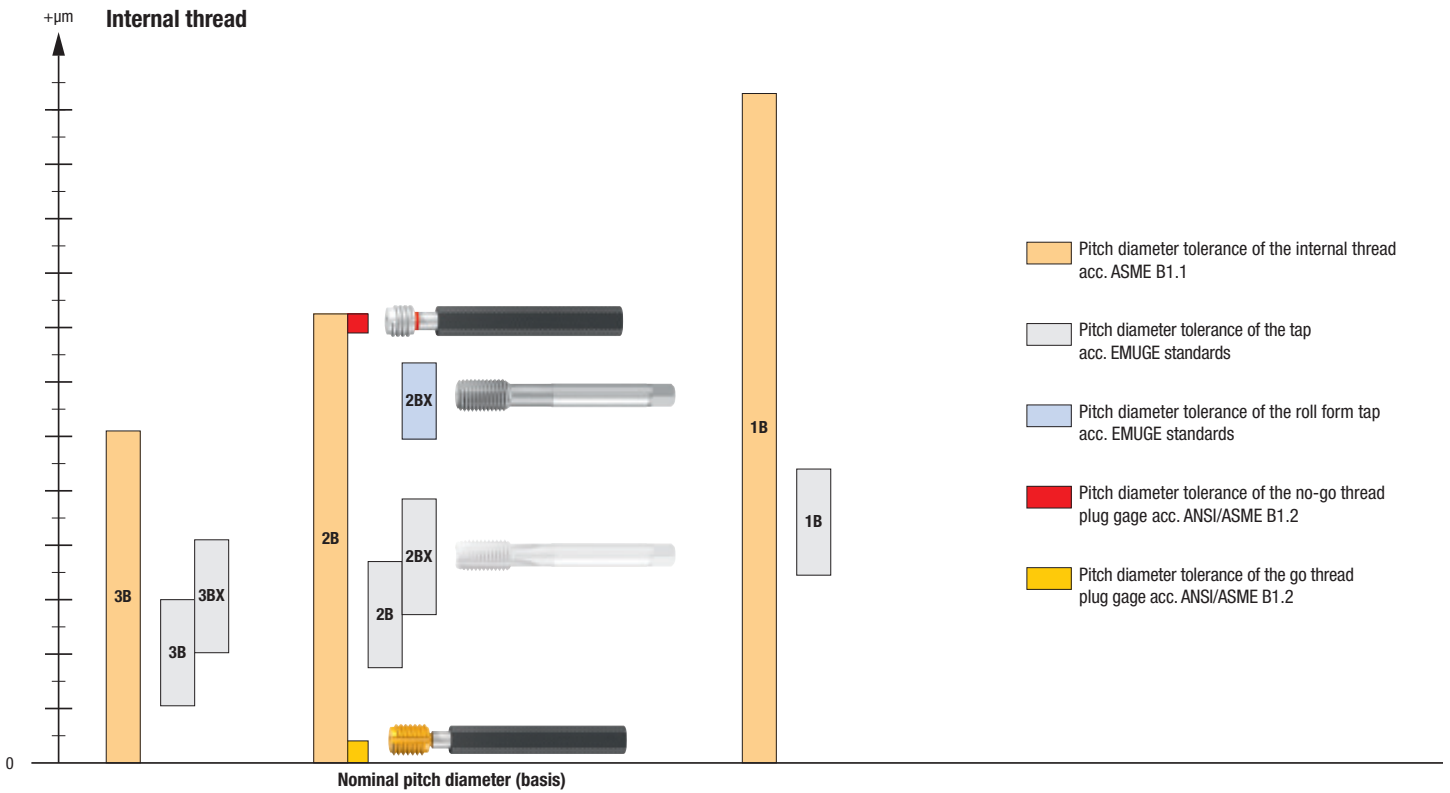

2.12 Tolerance zones of the pitch diameter on the Metric thread (graphic representation)

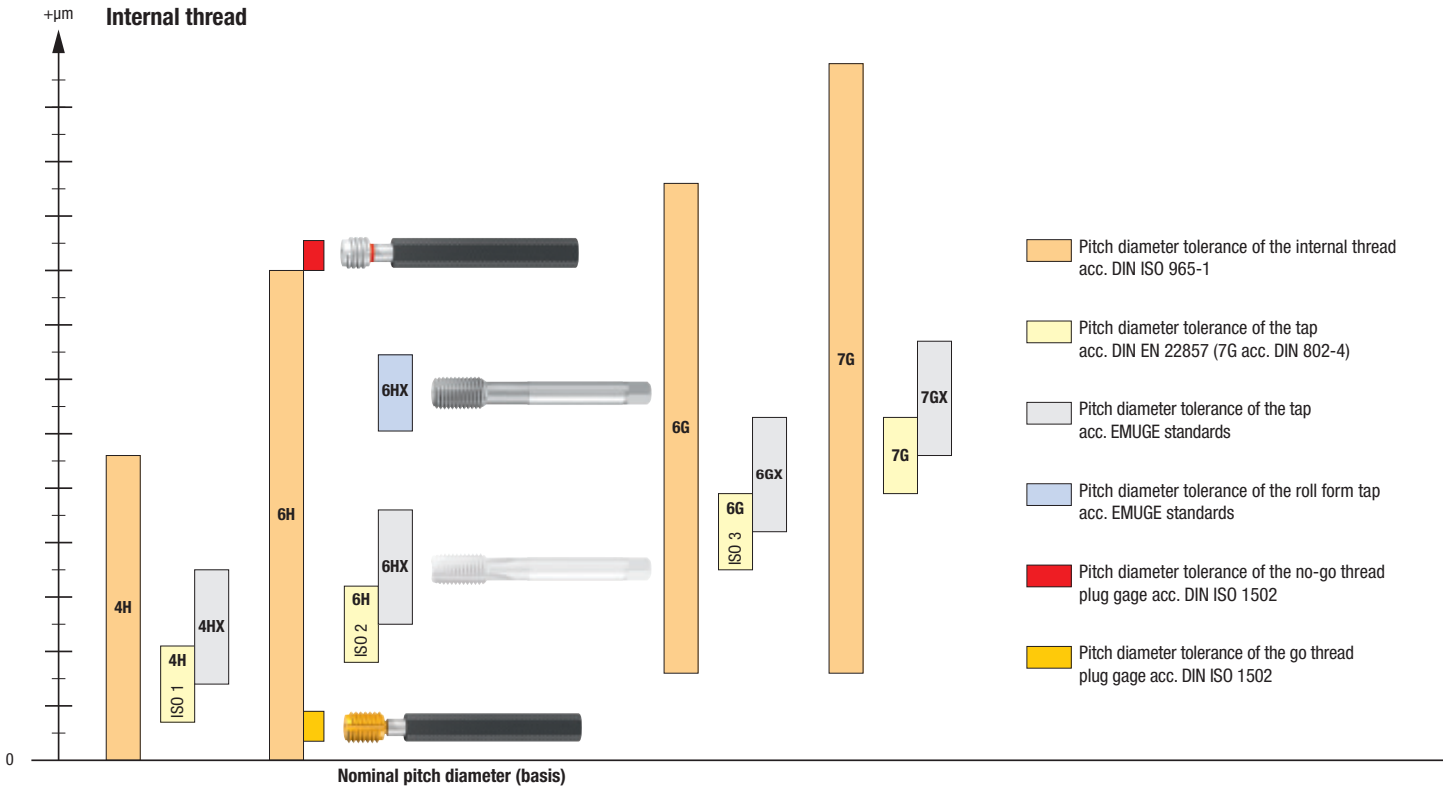

2.13 Cold forming and torque

Technical data of the workpiece material

Not all materials are suitable for cold forming. For that, they must show a minimum value of ductility and must not exceed a certain maximum strength. Suitable materials usually have a tensile strength of less than 1400 N/mm² and a minimum fracture strain of 5%. In addition, different materials and their alloys lead to very specific flow properties and strengthening characteristics. Obviously, wrought aluminum, high-strength steel or stainless materials will react in very different ways.

Torque

Torque, in the cold forming of threads, depends mostly on the workpiece material, the thread size, lubrication and thread hole preparatory diameter, as well as on the geometry and the coating of the tool. The influence of the preparatory diameter on torque is shown in the following diagram.

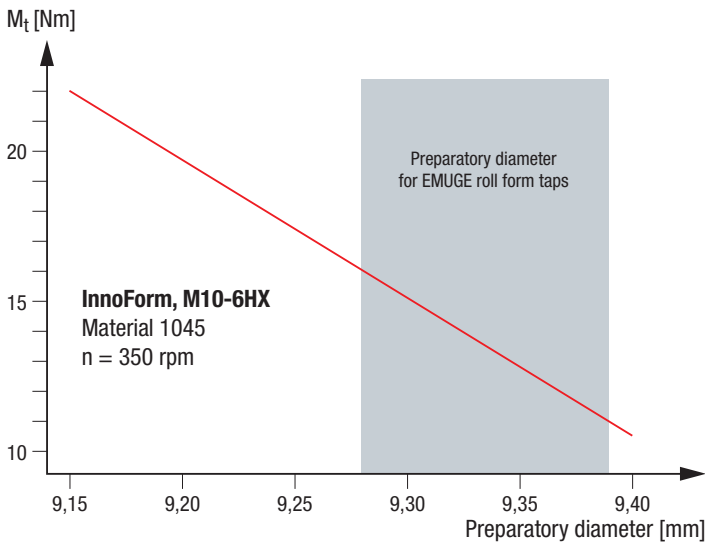

The following diagram demonstrates the difference in torque between thread cutting and cold forming.

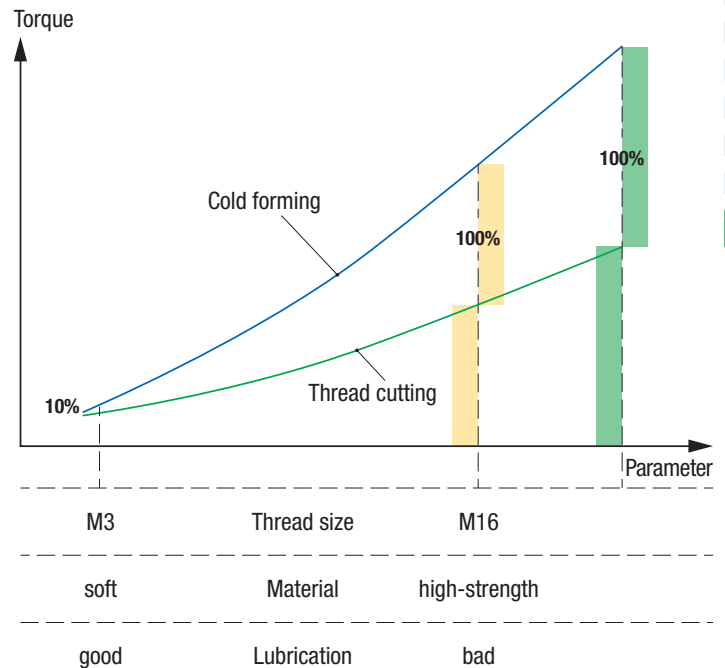

2.14 Cold forming as a production process

The cold forming of threads, according to DIN 8583-5, belongs to the pressure-forming processes. The internal thread is produced by the impression of a helical sequence of thread teeth into the formerly prepared thread hole, the desired profile is formed by pressure.

A roll form tap is provided with a lead taper and a cylindrical guiding part. The thread helix runs on through both parts. If you look at a cross-section of the tool, there is a polygon shape to be recognized at a right angle to the tool axis. This polygon shape provides forming lobes which carry the effective thread profile.

The lead portion of a roll form tap is made as a lead taper, in which the helical thread line is continuously increasing in diameter. In the cold-forming process, the lead taper produces the thread, the forming lobes penetrating the workpiece successively in a radial direction by forming the thread. During this process, the workpiece material “flows” from the thread crests along the thread flanks into the area of the minor thread diameter. This creates smooth flank surfaces and, in the minor diameter area, the typical space pocket.

The cylindrical guiding part of the roll form tap makes the surface of the produced thread even smoother, and serves to firmly guide the tool axially. Depending on the workpiece material, the essential advantages of cold forming include excellent surface quality but also increased static and dynamic strength of the thread. The length of the thread to be produced is not limited by chips which need to be removed, so process safety is extremely good.

The excellent self-guiding characteristics of a roll form tap prevent axial “miscutting”. The extraordinary stability of the tools is very helpful, especially with small diameters.

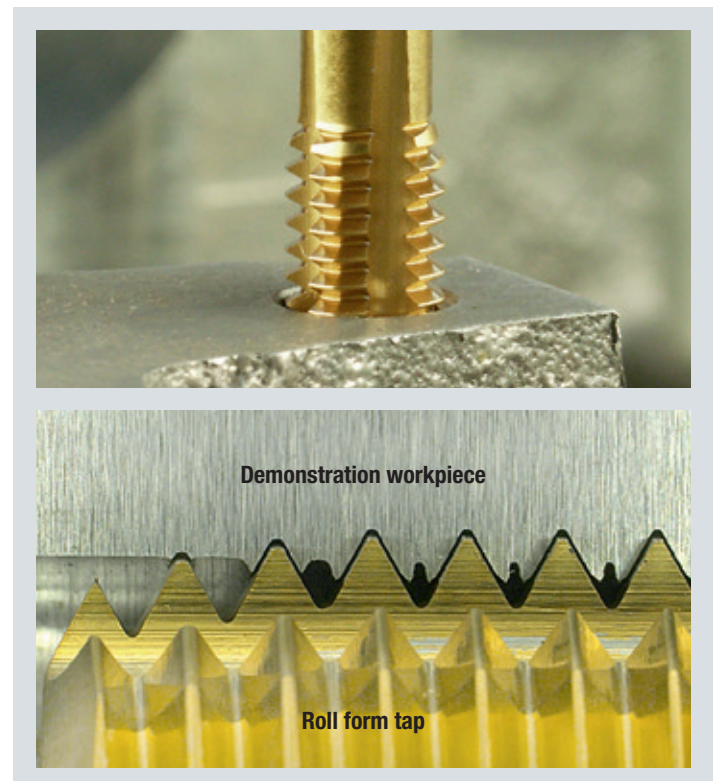

- Product Finder
- Vc
- UNC
- UNF
- M
- MF
- G
- STI
- SELF-LOCK
- Tech. Info



- Product Finder
- v_c
- UNC
- UNF
- M
- MF
- G
- STI
- SELF-LOCK
- Tech. Info**

2.15 The difference between a cut thread and a cold-formed thread

With a cut thread, the permissible stress values are limited due to the fact that the grain structure of the material is cut. Also, flank angle errors can occur easily; these will cause a very unfavourable distribution of stress on the thread and limit its holding strength. With a cold-formed thread, the grain of the material is not cut or interrupted, and the material itself shows increased strength, due to its having been compressed by cold-forming. Flank angle errors which are quite common in cut threads are prevented by the material being formed, without any play, along the thread flanks of the tap. The incomplete minor diameter, typical for cold-formed threads, has no influence on the stripping resistance of the thread.

Cold forming causes material strengthening on the thread flanks and especially in the root area of the thread. This strengthening of the material structure has a very positive influence on the vibration properties and the general resistance of the thread under dynamic stress.

Maximum thread depth, maximum thread pitch

The maximum thread depth to be achieved and the fastest possible thread pitch to be produced by cold-forming are a topic about which a general statement is impossible. The possible thread depth is definitely larger than it could be with a cutting tap. In practical work, it depends primarily on the quality of cooling/lubrication, and is limited by the constructional length of the tool.

The maximum thread pitch in cold forming is limited by the workpiece material properties.

Cut thread

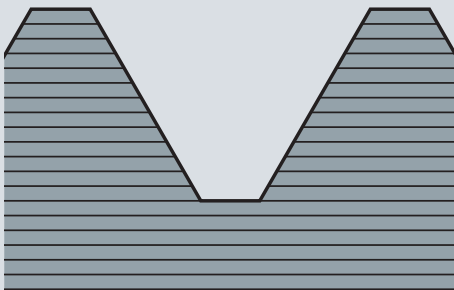
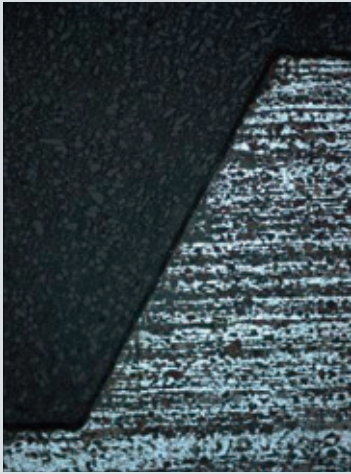

Grain structure in a cut thread

Cold-formed thread

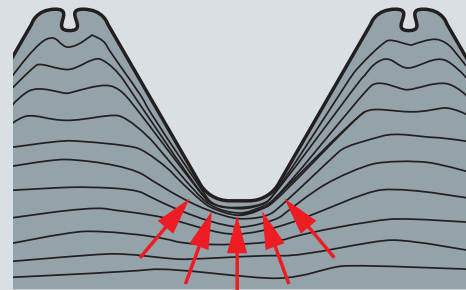
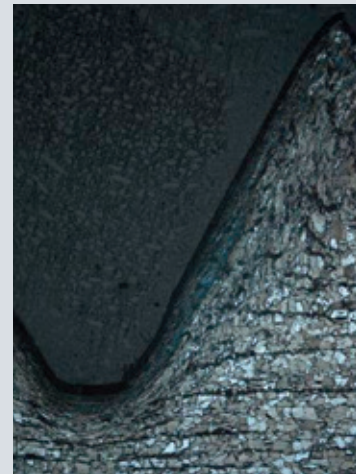

Grain structure in a cold-formed thread, strengthening in the root area / on the major diameter which is especially exposed to the danger of crack formation increases resistance

2.16 Thread hole preparatory diameter for roll form taps

The influence of the preparatory diameter

If the preparatory diameter is too small the workpiece material is overformed in the thread root and there are excessive process forces. If the preparatory diameter is too large the thread root is not sufficiently formed, the minor diameter is too small. In order to preclude such negative effects, the tolerance of the preparatory diameter is narrowed down from the start.

In some cases where the forming characteristics are very extraordinary it may be necessary to go without a standard preparatory diameter entirely, and to find the correct diameter by testing.

It is important to know that the preparatory diameter has a decisive influence on the minor diameter of the nut thread, as the following example shows. Every lack of precision, every kind of surface roughness will be mirrored in the finished internal thread and its minor diameter.

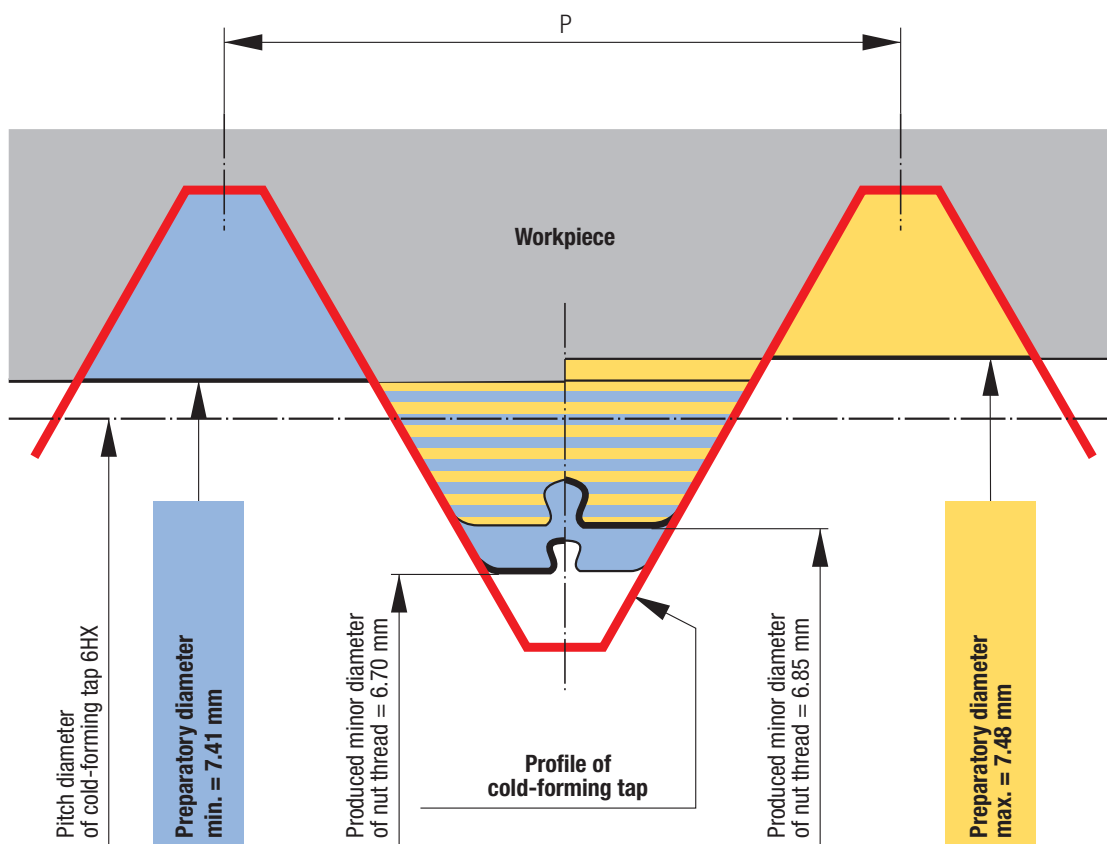

Cold-formed thread M8-6HX in corrosion- and acid-proof material, e.g. material no. 1.4571 or 1.4401, with different preparatory diameters.

Nut height = $2 \times d$
 $v_c = 21$ SFM
 $n = 255$ rpm

Coolant-lubricant:
 EMUGE thread cutting oil no. 5+ HIGH ALLOY

While the observation of the pitch diameter tolerance of the internal thread, e.g. ISO metric thread 6H, offers no problems usually, deviations in the minor diameter of the internal or nut thread must be expected, as demonstrated above.

The extended minor diameter tolerances for cold-formed internal threads are specified in DIN 13-50. This standard allows a 7H tolerance for the minor diameter of the nut thread, with a pitch diameter tolerance of 6H.

Product Finder

V_c

UNC

UNF

M

MF

G

STI

SELF-LOCK

Tech. Info



- Product Finder
- Vc
- UNC
- UNF
- M
- MF
- G
- STI
- SELF-LOCK
- Tech. Info

2.17 Recommended tap drill sizes for cold-forming internal threads

American Standard Threads

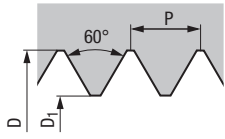

UNC

Unified coarse thread ASME B1.1 (Tol. 2B)

Nominal Size	P [T.P.I.]	D ₁ (2B)		Rec. tap drill size
		min.	max.	
D				
No. 1	64	0.0661	0.0681	0.0669
No. 2	56	0.0780	0.0799	0.0787
No. 3	48	0.0894	0.0917	0.0906
No. 4	40	0.1004	0.1016	0.1004
No. 5	40	0.1134	0.1154	0.1142
No. 6	32	0.1228	0.1252	0.1240
No. 8	32	0.1492	0.1508	0.1496
No. 10	24	0.1697	0.1724	0.1713
No. 12	24	0.1957	0.1980	0.1969
1/4	20	0.2252	0.2276	0.2264
5/16	18	0.2846	0.2890	0.2874
3/8	16	0.3437	0.3480	0.3465
7/16	14	0.4016	0.4051	0.4035
1/2	13	0.4610	0.4661	0.4646
9/16	12	0.5201	0.5252	0.5236
5/8	11	0.5787	0.5843	0.5827
3/4	10	0.6980	0.7043	0.7028
7/8	9	0.8169	0.8248	0.8228
1	8	0.9346	0.9429	0.9409

UNF

Unified fine thread ASME B1.1 (Tol. 2B)

Nominal Size	P [T.P.I.]	D ₁ (2B)		Rec. tap drill size
		min.	max.	
D				
No. 0	80	0.0547	0.0563	0.0551
No. 1	72	0.0669	0.0681	0.0669
No. 2	64	0.0791	0.0807	0.0795
No. 3	56	0.0909	0.0925	0.0913
No. 4	48	0.1024	0.1043	0.1031
No. 5	44	0.1146	0.1161	0.1150
No. 6	40	0.1264	0.1280	0.1268
No. 8	36	0.1508	0.1528	0.1516
No. 10	32	0.1752	0.1764	0.1752
No. 12	28	0.1988	0.2020	0.2008
1/4	28	0.2331	0.2354	0.2343
5/16	24	0.2925	0.2949	0.2933
3/8	24	0.3551	0.3579	0.3563
7/16	20	0.4130	0.4169	0.4154
1/2	20	0.4756	0.4799	0.4783
9/16	18	0.5354	0.5390	0.5374
5/8	18	0.5980	0.6020	0.6004
3/4	16	0.7193	0.7244	0.7224
7/8	14	0.8398	0.8445	0.8425
1	12	0.9583	0.9646	0.9626

ISO Metric Threads

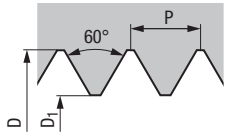

M

ISO Metric coarse thread DIN 13 (Tol. 6H)

Nominal Size	P [mm]	D ₁ (6H)		Rec. tap drill size	
		min. [mm]	max. [mm]	[mm]	[inch]
D					
M 2	0.4	1.84	1.88	1.85	0.0728
M 2.5	0.45	2.32	2.36	2.33	0.0917
M 3	0.5	2.79	2.83	2.8	0.1102
M 3.5	0.6	3.24	3.28	3.25	0.1280
M 4	0.7	3.69	3.73	3.7	0.1457
M 4.5	0.75	4.16	4.23	4.2	0.1654
M 5	0.8	4.64	4.68	4.65	0.1831
M 6	1	5.55	5.63	5.6	0.2205
M 7	1	6.55	6.64	6.6	0.2598
M 8	1.25	7.41	7.49	7.45	0.2933
M 10	1.5	9.28	9.39	9.35	0.3681
M 12	1.75	11.16	11.29	11.25	0.4429
M 14	2	13.02	13.14	13.1	0.5157
M 16	2	15.02	15.14	15.1	0.5945
M 18	2.5	16.73	16.89	16.85	0.6634
M 20	2.5	18.73	18.9	18.85	0.7421
M 22	2.5	20.73	20.9	20.85	0.8209
M 24	3	22.47	22.65	22.6	0.8898

MF

ISO Metric fine thread DIN 13 (Tol. 6H)

Nominal Size	P [mm]	D ₁ (6H)		Rec. tap drill size	
		min. [mm]	max. [mm]	[mm]	[inch]
D					
M 4 x 0.5		3.79	3.83	3.8	0.1496
M 5 x 0.5		4.79	4.83	4.8	0.1890
M 6 x 0.75		5.67	5.73	5.7	0.2244
M 8 x 0.75		7.67	7.74	7.7	0.3031
M 8 x 1		7.55	7.64	7.6	0.2992
M 10 x 1		9.55	9.64	9.6	0.3780
M 10 x 1.25		9.41	9.49	9.45	0.3720
M 12 x 1.5		11.29	11.39	11.35	0.4469
M 14 x 1.5		13.29	13.39	13.35	0.5256
M 16 x 1.5		15.29	15.39	15.35	0.6043
M 18 x 1.5		17.29	17.39	17.35	0.6831
M 20 x 1.5		19.29	19.40	19.35	0.7618
M 22 x 1.5		21.29	21.40	21.35	0.8406
M 24 x 1.5		23.30	23.40	23.35	0.9193

Tap drill sizes of Metric fine threads which are not listed can be found by considering the diameter difference.

Straight Pipe Threads

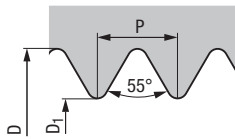

G

Whitworth pipe thread DIN EN ISO 228

Nominal Size	P [T.P.I.]	D ₁		Rec. tap drill size	
		min. [mm]	max. [mm]	[mm]	[inch]
D					
G 1/16	28	7.25	7.29	7.25	0.2854
G 1/8	28	9.25	9.29	9.25	0.3642
G 1/4	19	12.48	12.59	12.55	0.4941
G 3/8	19	15.99	16.09	16.05	0.6319
G 1/2	14	20.02	20.15	20.1	0.7913
G 5/8	14	21.97	22.1	22.05	0.8681
G 3/4	14	25.5	25.65	25.6	1.0079
G 7/8	14	29.26	29.4	29.35	1.1555
G 1	11	32.05	32.21	32.15	1.2657

2.17 Recommended tap drill sizes for cold-forming internal threads

STI-UNC

Unified coarse thread
ASME B18.29.1

For wire thread inserts

Nominal Size	P [T.P.I.]	D ₁ (2B)		Rec. tap drill size
		min.	max.	
STI-No. 2	56	0.1004	0.1016	0.1004
STI-No. 4	40	0.1323	0.1339	0.1327
STI-No. 6	32	0.1630	0.1646	0.1634
STI-No. 8	32	0.1894	0.1921	0.1909
STI-No. 10	24	0.2228	0.2256	0.2244
STI 1/4	20	0.2894	0.2929	0.2913
STI 5/16	18	0.3563	0.3598	0.3583
STI 3/8	16	0.4240	0.4287	0.4272
STI 7/16	14	0.4933	0.4976	0.4961
STI 1/2	13	0.5602	0.5646	0.5630

STI-UNF

Unified fine thread
ASME B18.29.1

For wire thread inserts

Nominal Size	P [T.P.I.]	D ₁ (2B)		Rec. tap drill size
		min.	max.	
STI-No. 4	48	0.1291	0.1311	0.1299
STI-No. 6	40	0.1583	0.1606	0.1594
STI-No. 8	36	0.1866	0.1882	0.1870
STI-No. 10	32	0.2150	0.2177	0.2165
STI 1/4	28	0.2783	0.2811	0.2795
STI 5/16	24	0.3457	0.3480	0.3465
STI 3/8	24	0.4083	0.4110	0.4094
STI 7/16	20	0.4772	0.4799	0.4783
STI 1/2	20	0.5398	0.5429	0.5413

Screw Thread Insert Threads (STI)

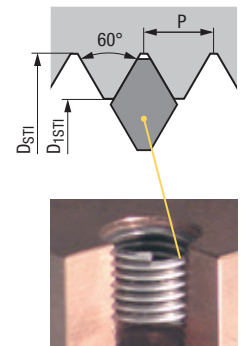

LK-UNC

Unified SELF-LOCK coarse thread
EMUGE standard

Nominal Size	P [T.P.I.]	D ₁		Rec. tap drill size
		min.	max.	
LK No. 4	40	0.1035	0.1055	0.1043
LK No. 6	32	0.1280	0.1303	0.1280
LK No. 8	32	0.1539	0.1563	0.1555
LK No. 10	24	0.1752	0.1783	0.1772
LK No. 12	24	0.2012	0.2047	0.2028
LK 1/4	20	0.2315	0.2354	0.2323
LK 5/16	18	0.2913	0.2961	0.2933
LK 3/8	16	0.3508	0.3559	0.3524
LK 7/16	14	0.4091	0.4146	0.4094
LK 1/2	13	0.4689	0.4752	0.4724

LK-UNF

Unified SELF-LOCK fine thread
EMUGE standard

Nominal Size	P [T.P.I.]	D ₁		Rec. tap drill size
		min.	max.	
LK No. 4	48	0.1047	0.1067	0.1055
LK No. 6	40	0.1295	0.1315	0.1299
LK No. 8	36	0.1543	0.1567	0.1555
LK No. 10	32	0.1799	0.1823	0.1811
LK 1/4	28	0.2382	0.2409	0.2382
LK 5/16	24	0.2980	0.3016	0.2992
LK 3/8	24	0.3606	0.3638	0.3622
LK 7/16	20	0.4193	0.4232	0.4213
LK 1/2	20	0.4819	0.4858	0.4843

Self-Locking Threads

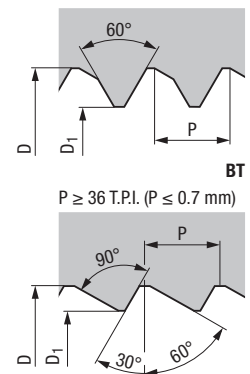

LK-M

Metric SELF-LOCK coarse thread
EMUGE standard

Nominal Size	P [mm]	D ₁		Rec. tap drill size	
		min. [mm]	max. [mm]	[mm]	[inch]
LK-M 3	0.5	2.82	2.88	2.85	0.1122
LK-M 4	0.7	3.77	3.83	3.8	0.1496
LK-M 5	0.8	4.77	4.83	4.8	0.1890
LK-M 6	1	5.7	5.78	5.7	0.2244
LK-M 8	1.25	7.58	7.68	7.6	0.2992
LK-M 10	1.5	9.48	9.58	9.5	0.3740

The recommended preparatory diameters enable a cold-formed minor diameter of the thread within tolerance (for M and MF according to DIN 13-50). Preconditions include a stable clamping of tool and workpiece as well as solid carbide twist drills which are new or as good as new.

In order to optimize tool life, larger thread hole preparatory diameters may be used. But it is necessary to ensure that the minor diameter of the thread complies with the tolerance (for M and MF according to DIN 13-50).

We recommend a smaller preparatory diameter by 0.05 mm respectively 0.002 in for difficult to form materials (such as aluminum cast alloys) for $P \geq 1$ mm respectively from 24 T.P.I.

The recommended preparatory diameters were carefully determined and tested in the field. In rare cases it may happen that the recommended preparatory diameters do not provide the desired minor diameter of the internal thread. In such cases the suitable preparatory diameters must be determined in tests.

- Product Finder
- V_c
- UNC
- UNF
- M
- MF
- G
- STI
- SELF-LOCK
- Tech. Info



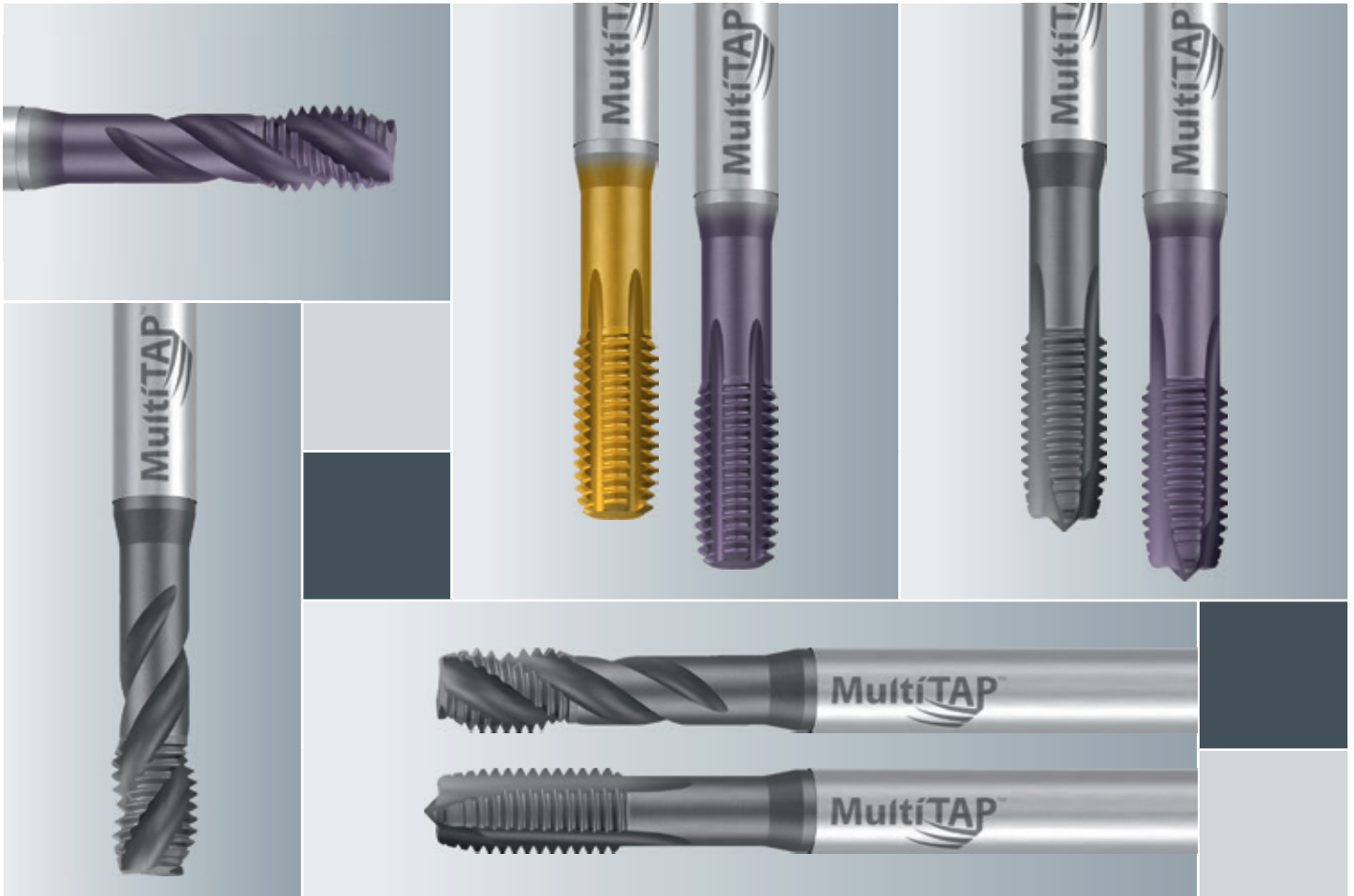

Multi Taps and Multi Roll Form Taps



	Page
Contents	212 - 213
Product Finder and Cutting Data	214 - 215
Product Pages	216 - 226

The Original

MultiTAP™ by EMUGE

Introducing the EXPANDED MultiTAP line.





From cut taps to form taps, extended lengths to different coatings, EMUGE, the inventor and leader of the high performance multi-purpose tap, now offers the broadest line in the industry.

MultiTAP cuts a wide range of materials – carbon steel, steel alloys, stainless steel, aluminum, cast iron, copper, brass, and bronze. And MultiTAP is uniquely designed to produce threads within both **2B and 3B classes** of fit, eliminating the guesswork required when calculating H-limits.

MultiTAP features an innovative geometric design and a special base material and surface treatment, allowing it to handle numerous materials and applications. EMUGE has designed MultiTAP as an **affordable**, yet high performance tapping solution.

MultiTAP will significantly improve thread quality and boost output while reducing production costs, handling most common materials and applications. **MultiTAP eliminates the need to stock numerous types of taps in the tool crib.**



Taps with reinforced shank		Taps with reduced shank		Taps with extra long shank		Roll form taps with reinforced shank		Roll form taps with reduced shank	
									
Rekord 1 – Plug Enorm 1 – Semi Bottoming		Rekord 2 – Plug Enorm 2 – Semi Bottoming		Rekord 1/2-LS – Plug Enorm 1/2-LS – Semi Bottoming		MultiForm 1		MultiForm 2	
DIN Length ANSI Shank	DIN Length DIN Shank	DIN Length ANSI Shank	DIN Length DIN Shank	Extra Length ANSI Shank	Extra Length DIN Shank	DIN Length ANSI Shank	DIN Length DIN Shank	DIN Length ANSI Shank	

Page

216		216		217		223		223	UNC
218		218		219		224		224	UNF
220	221	220	221		222		225		M



Product finder and cutting data

Please note:

The cutting / circumferential speeds (v_c in SFM) listed in the respective columns are standard values which have to be adjusted to individual work conditions (material, lubrication, machine etc.).

The suitability is marked as follows:

- Preferred suitable tap / roll form tap
- Suitable tap / roll form tap

 = DIN form / threads (chamfer length)

 = DIN form / threads (lead taper length)

Application – Material		Hardness Range			Material Examples		
		HRC	BHN	N/mm ²			
Steel materials							
P	1.1	Cold-extrusion steels, Construction steels, Free-cutting steels, etc.		≤ 180	≤ 600	1010 / 1018 / 1020 / 12L14 / 12L15 / A36 / T1	
	2.1	Construction steels, Cementation steels, Steel castings, etc.	≤ 22	≤ 235	≤ 800	A36 / T1 / 1030-1095 / 4140 / 4340 / 8620	
	3.1	Cementation steels, Heat-treatable steels, Cold work steels, etc.	≤ 31	≤ 295	≤ 1000	4140 / 4340 / 8620 / P20 / H13 / D2 / A2 / S7 / H1150	
	4.1	Heat-treatable steels, Cold work steels, Nitriding steels, etc.	≤ 38	≤ 355	≤ 1200	4140 / 4340 / 8620 / P20 / H13 / D2 / 300M / 52100 / M1-M42	
	5.1	High-alloyed steels, Cold work steels, Hot work steels, etc.	≤ 44	≤ 415	≤ 1400	4140 / 4340 / 8620 / P20 / H13 / D2 / 300M / 52100	
Stainless steel materials							
M	1.1	Ferritic, martensitic	≤ 29	≤ 280	≤ 950	410 / 440 / 440C / 17-4 PH	
	2.1	Austenitic	≤ 29	≤ 280	≤ 950	303 / 304 / 316 / 316L / 321	
	3.1	Austenitic-ferritic (Duplex)	≤ 35	≤ 325	≤ 1100		
	4.1	Austenitic-ferritic heat-resistant (Super Duplex)	≤ 39	≤ 370	≤ 1250		
Cast materials							
K	1.1	Cast iron with lamellar graphite (GJL)		30 - 75	100 - 250	Grey cast irons G10-GG40	
	1.2			75 - 135	250 - 450		
	2.1	Cast iron with nodular graphite (GJS)		105 - 150	350 - 500	Nodular GGG40-GGG70	
	2.2			150 - 265	500 - 900		
	3.1	Cast iron with vermicular graphite (GJV)		90 - 120	300 - 400	Compact graphite iron (CGI)	
	3.2			120 - 150	400 - 500		
	4.1	Malleable cast iron (GTMW, GTMB)		70 - 145	250 - 500	White iron	
4.2			150 - 235	500 - 800			
Non ferrous materials							
Aluminum alloys							
N	1.1	Aluminum wrought alloys		≤ 60	≤ 200	7075	
	1.2			≤ 105	≤ 350	6061-T6 / 2024-T4	
	1.3			≤ 165	≤ 550		
	1.4	Aluminum cast alloys Si ≤ 7%					
	1.5	Aluminum cast alloys 7% < Si ≤ 12%					
	1.6	Aluminum cast alloys 12% < Si ≤ 17%					
Copper alloys							
N	2.1	Pure copper, low-alloyed copper		≤ 120	≤ 400		
	2.2	Copper-zinc alloys (brass, long-chipping)		≤ 165	≤ 550		
	2.3	Copper-zinc alloys (brass, short-chipping)		≤ 165	≤ 550		
	2.4	Copper-aluminum alloys (alu bronze, long-chipping)		≤ 235	≤ 800		
	2.5	Copper-tin alloys (tin bronze, long-chipping)		≤ 205	≤ 700		
	2.6	Copper-tin alloys (tin bronze, short-chipping)		≤ 120	≤ 400		
	2.7	Special copper alloys		≤ 180	≤ 600		
	2.8			≤ 44	≤ 415	≤ 1400	
Magnesium alloys							
N	3.1	Magnesium wrought alloys		≤ 150	≤ 500		
	3.2	Magnesium cast alloys		≤ 150	≤ 500		
Synthetics							
N	4.1	Duroplastics (short-chipping)					
	4.2	Thermoplastics (long-chipping)					
	4.3	Fibre-reinforced synthetics (fibre content ≤ 30%)					
	4.4	Fibre-reinforced synthetics (fibre content > 30%)					
Special materials							
N	5.1	Graphite					
	5.2	Tungsten-copper alloys					
	5.3	Composite materials					
Special materials							
Titanium alloys							
S	1.1	Pure titanium		≤ 135	≤ 450	CP1 / CP2	
	1.2	Titanium alloys		≤ 265	≤ 900	6AL4V	
	1.3			≤ 39	≤ 370	≤ 1250	
Nickel alloys, cobalt alloys and iron alloys							
S	2.1	Pure nickel		≤ 180	≤ 600		
	2.2	Nickel-base alloys		≤ 31	≤ 295	Monel 500, 718 Inconel annealed	
	2.3			≤ 49	≤ 475	≤ 1600	718 Inconel
	2.4	Cobalt-base alloys		≤ 31	≤ 295	≤ 1000	
	2.5			≤ 49	≤ 475	≤ 1600	Haynes 25
	2.6	Iron-base alloys		≤ 46	≤ 445	≤ 1500	Incoloy 925
Hard materials							
H	1.1	High strength steels, hardened steels, hard castings		44 - 50			
	1.2			50 - 55			
	1.3			55 - 60			
	1.4			60 - 63			
	1.5			63 - 66			



Taps

Roll Form Taps



Rekord B-MULTI NT2

Rekord B-MULTI TiCN

Enorm MULTI NE2

Enorm MULTI TiCN

InnoForm MULTI/E-SN TiN

InnoForm MULTI/E-SN TiCN



B / 4-5

B / 4-5

C / 2-3

C / 2-3

E / 1.5-2

E / 1.5-2



Thread Depth and Hole Type

max. 3 x d₁



max. 2.5 x d₁



max. 3 x d₁



Thread Depth and Hole Type

UNC	216, 217	216	216, 217	216	223	223	UNC
UNF	218, 219	218	218, 219	218	224	224	UNF
UNEF, UN-8							UNEF, UN-8
M	220 - 222	220, 221	220 - 222	220, 221	225	225	M
MF							MF
NPSM/NPSC							NPSM/NPSC
NPSF							NPSF
Rp (BSPP)							Rp (BSPP)
G							G
NPT							NPT
NPTF							NPTF
Rc (BSPT)							Rc (BSPT)
STI							STI
SELF-LOCK							SELF-LOCK

Page

	25 - 60	25 - 60	25 - 60	25 - 60	35 - 85	35 - 85	1.1
	25 - 60	25 - 60	25 - 60	25 - 60	35 - 85	35 - 85	2.1
	15 - 40	15 - 40	15 - 40	15 - 40	35 - 75	35 - 75	3.1
	10 - 35	10 - 35	10 - 35	10 - 35	15 - 40	15 - 40	4.1
							5.1
	10 - 30	10 - 30	10 - 30	10 - 30	15 - 45 ²⁾	15 - 45 ²⁾	1.1
	10 - 25	10 - 25	10 - 25	10 - 25	15 - 45 ²⁾	15 - 45 ²⁾	2.1
							3.1
							4.1
	35 - 65	35 - 65	35 - 65	35 - 65			1.1
	15 - 50	15 - 50	15 - 50	15 - 50			1.2
							2.1
	15 - 50	15 - 50	15 - 50	15 - 50			2.2
							3.1
	35 - 65	35 - 65	35 - 65	35 - 65			3.2
							4.1
							4.2
	35 - 65	35 - 65	35 - 65	35 - 65	35 - 100	35 - 100	1.1
	35 - 65	35 - 65	35 - 65	35 - 65	35 - 100	35 - 100	1.2
	35 - 65	35 - 65	35 - 65	35 - 65	35 - 100	35 - 100	1.3
	20 - 50	20 - 50	20 - 50	20 - 50	35 - 85	35 - 85	1.4
							1.5
							1.6
	15 - 40	15 - 40	15 - 40	15 - 40	35 - 100	35 - 100	2.1
	35 - 80	35 - 80	35 - 80	35 - 80	35 - 100	35 - 100	2.2
	35 - 80	35 - 80	35 - 80	35 - 80	35 - 100	35 - 100	2.3
	10 - 35	10 - 35	10 - 35	10 - 35	20 - 50	20 - 50	2.4
	15 - 45	15 - 45	15 - 45	15 - 45	35 - 85	35 - 85	2.5
							2.6
							2.7
							2.8
							3.1
							3.2
							4.1
							4.2
							4.3
							4.4
							5.1
							5.2
							5.3
							1.1
							1.2
							1.3
							2.1
							2.2
							2.3
							2.4
							2.5
							2.6
							1.1
							1.2
							1.3
							1.4
							1.5

Product Finder

V_c

UNC

UNF

M



- Product Finder
- V_c
- UNC
- UNF
- M

DIN Length · ANSI Shank

Overall length acc. to DIN 371, DIN 376

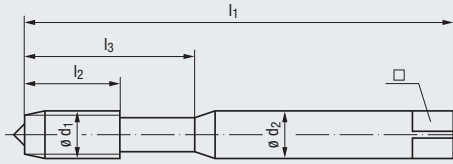

Reinforced Shank
(No.1 - 3/8)

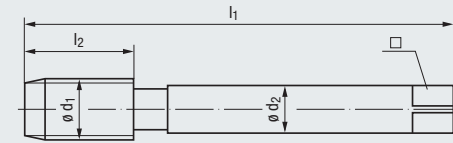

Reduced Shank
(7/16 - 1)

MULTI

Wide Material Range



UNC

Unified Coarse Thread
ASME B1.1

Class of Fit
Coating
Cutting Material
Technical Characteristics

2B	2B	2B	2B
NT2	TICN	NE2	TICN
HSS Extra	HSS Extra	HSS Extra	HSS Extra
B / 4-5	B / 4-5	R35	R35
E / O / P	E / O / P	E / O / P	E / O / P

Thread Depth and Hole Shape

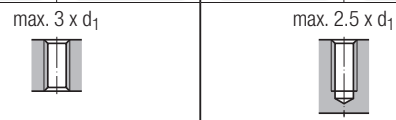

Applications – Material

P 1.1-4.1	P 1.1-4.1	P 1.1-4.1	P 1.1-4.1
M 1.1-2.1	M 1.1-2.1	M 1.1-2.1	M 1.1-2.1
K 1.1, 2.1	K 1.1, 2.1	K 1.1, 2.1	K 1.1, 2.1
K 3.1, 4.1	K 3.1, 4.1	K 3.1, 4.1	K 3.1, 4.1
N 1.1-1.4, 2.1-5	N 1.1-1.4, 2.1-5	N 1.1-1.4, 2.1-5	N 1.1-1.4, 2.1-5

Reinforced Shank

Nominal Size ϕd_1	T.P.I.	l_1	l_2	inch		ϕd_2	\square	Tool Identification		BU497300		BU499300		BU533200		BU539300	
				l_3	ϕd_2			Rekord 1B-MULTI NT2	Flutes	Rekord 1B-MULTI TICN	Flutes	Enorm 1-MULTI NE2	Flutes	Enorm 1-MULTI TICN	Flutes		
No. 1	64	1.772	0.276	0.472	0.141	0.110	0.0595	.5000									
No. 2	56	1.772	0.276	0.472	0.141	0.110	0.0700	.5001									
No. 3	48	1.969	0.354	0.551	0.141	0.110	0.0820	.5002									
No. 4	40	2.205	0.433	0.709	0.141	0.110	0.0890	.5003	●	2	●	2	●	2	●	2	
No. 5	40	2.205	0.433	0.709	0.141	0.110	0.1015	.5004	●	3	●	3	●	3	●	3	
No. 6	32	2.205	0.472	0.787	0.141	0.110	0.1110	.5005	●	3	●	3	●	3	●	3	
No. 8	32	2.480	0.512	0.827	0.168	0.131	0.1360	.5006	●	3	●	3	●	3	●	3	
No.10	24	2.756	0.591	0.984	0.194	0.152	0.1520	.5007	●	3	●	3	●	3	●	3	
No.12	24	3.150	0.630	1.142	0.220	0.165	0.1770	.5008	●	3	●	3	●	3	●	3	
1/4	20	3.150	0.669	1.181	0.255	0.191	0.2040	.5009	●	3	●	3	●	3	●	3	
5/16	18	3.543	0.787	1.378	0.318	0.238	0.2610	.5010	●	3	●	3	●	3	●	3	
3/8	16	3.937	0.866	1.535	0.381	0.286	0.3160	.5011	●	3	●	3	●	3	●	3	

Reduced Shank

Nominal Size ϕd_1	T.P.I.	l_1	l_2	inch		ϕd_2	\square	Tool Identification		CU497300		CU499300		CU533200		CU539300	
				l_3	ϕd_2			Rekord 2B-MULTI NT2	Flutes	Rekord 2B-MULTI TICN	Flutes	Enorm 2-MULTI NE2	Flutes	Enorm 2-MULTI TICN	Flutes		
7/16	14	3.937	0.866	—	0.323	0.242	0.3680	.5012	●	3	●	3	●	3	●	3	
1/2	13	4.331	0.984	—	0.367	0.275	0.4219	.5013	●	3	●	3	●	3	●	3	
9/16	12	4.331	1.024	—	0.429	0.322	0.4844	.5014	●	3	●	3	●	3	●	3	
5/8	11	4.331	1.063	—	0.480	0.360	0.5313	.5015	●	3	●	3	●	3	●	3	
3/4	10	4.921	1.181	—	0.590	0.442	0.6563	.5016	●	3	●	3	●	3	●	3	
7/8	9	5.512	1.260	—	0.697	0.523	0.7656	.5017	●	3	●	3	●	4	●	4	
1	8	6.299	1.417	—	0.800	0.600	0.8750	.5018	●	3	●	3	●	4	●	4	

Extra Length • ANSI Shank



MULTI
Wide Material
Range



With extra long shank

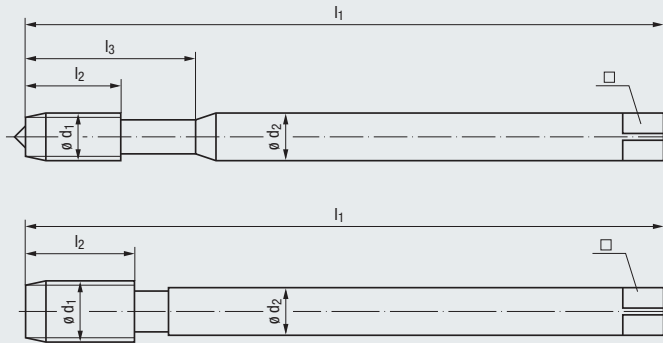

Reinforced Shank
(No.6 - 3/8)

Reduced Shank
(7/16 - 5/8)

UNC



Unified Coarse Thread
ASME B1.1

Class of Fit
Coating
Cutting Material
Technical Characteristics

2B	2B
NT2	NE2
HSS Extra	HSS Extra
R35	R35
B / 4-5	C / 2-3
E / O / P	E / O / P

Thread Depth
and Hole Shape



Applications – Material

P 1.1-4.1	P 1.1-4.1
M 1.1-2.1	M 1.1-2.1
K 1.1, 2.1	K 1.1, 2.1
K 3.1, 4.1	K 3.1, 4.1
N 1.1-1.4, 2.1-5	N 1.1-1.4, 2.1-5

Reinforced Shank

Nominal Size ø d ₁	T.P.I.	l ₁	l ₂	inch l ₃	ø d ₂	□	Tool Identification		BU797300		BU783200	
							Rekord 1B-MULTI LS-NT2	Flutes	Enorm 1-MULTI LS-NE2	Flutes		
No. 6	32	4.409	0.472	0.787	0.141	0.110	.5005	●	3	●	3	
No. 8	32	4.921	0.512	0.827	0.168	0.131	.5006	●	3	●	3	
No. 10	24	5.512	0.591	0.984	0.194	0.152	.5007	●	3	●	3	
1/4	20	6.299	0.669	1.181	0.255	0.191	.5009	●	3	●	3	
5/16	18	7.087	0.787	1.378	0.318	0.238	.5010	●	3	●	3	
3/8	16	7.087	0.866	1.535	0.381	0.286	.5011	●	3	●	3	

Reduced Shank

Nominal Size ø d ₁	T.P.I.	l ₁	l ₂	inch l ₃	ø d ₂	□	Tool Identification		CU797300		CU783200	
							Rekord 2B-MULTI LS-NT2	Flutes	Enorm 2-MULTI LS-NE2	Flutes		
7/16	14	7.874	0.866	—	0.323	0.242	0.3680	.5012	●	3	●	3
1/2	13	8.819	0.984	—	0.367	0.275	0.4219	.5013	●	3	●	3
5/8	11	8.819	1.063	—	0.480	0.360	0.5313	.5015	●	3	●	3

● = In stock
★ = Allow 7 days for delivery

Product Finder

V_c

UNC

UNF

M



- Product Finder
- V_c
- UNC
- UNF
- M

DIN Length • ANSI Shank

Overall length acc. to DIN 371, DIN 374

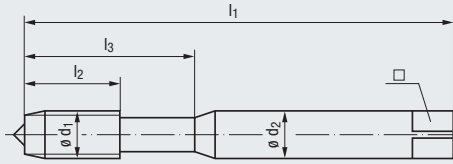

Reinforced Shank
(No.4 - 3/8)

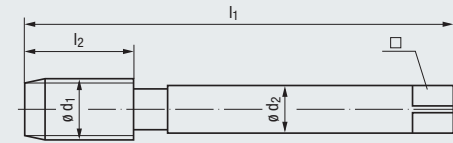

Reduced Shank
(7/16 - 1)

MULTI

Wide Material Range



Unified Fine Thread ASME B1.1

Class of Fit
Coating
Cutting Material
Technical Characteristics



2B	2B	2B	2B
NT2	TICN	NE2	TICN
HSS Extra	HSS Extra	HSS Extra	HSS Extra
B / 4-5	B / 4-5	R35	R35
E / O / P	E / O / P	E / O / P	E / O / P

Thread Depth and Hole Shape

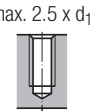

Applications – Material

P 1.1-4.1	P 1.1-4.1	P 1.1-4.1	P 1.1-4.1
M 1.1-2.1	M 1.1-2.1	M 1.1-2.1	M 1.1-2.1
K 1.1, 2.1	K 1.1, 2.1	K 1.1, 2.1	K 1.1, 2.1
K 3.1, 4.1	K 3.1, 4.1	K 3.1, 4.1	K 3.1, 4.1
N 1.1-1.4, 2.1-5	N 1.1-1.4, 2.1-5	N 1.1-1.4, 2.1-5	N 1.1-1.4, 2.1-5

Reinforced Shank

Nominal Size ø d ₁	T.P.I.	l ₁	l ₂	inch		□	Tool Identification		BU497300		BU499300		BU533200		BU539300	
				l ₃	ø d ₂		Rekord 1B-MULTI NT2	Flutes	Rekord 1B-MULTI TICN	Flutes	Enorm 1-MULTI NE2	Flutes	Enorm 1-MULTI TICN	Flutes		
No. 4	48	2.205	0.433	0.709	0.141	0.110	0.0945	.5037	●	2	●	2	●	2	●	2
No. 5	44	2.205	0.433	0.709	0.141	0.110	0.1063	.5038	●	3	●	3	●	3	●	3
No. 6	40	2.205	0.472	0.787	0.141	0.110	0.1181	.5039	●	3	●	3	●	3	●	3
No. 8	36	2.480	0.512	0.827	0.168	0.131	0.1378	.5040	●	3	●	3	●	3	●	3
No. 10	32	2.756	0.512	0.984	0.194	0.152	0.1614	.5041	●	3	●	3	●	3	●	3
No. 12	28	3.150	0.630	1.142	0.220	0.165	0.1820	.5042	●	3	●	3	●	3	●	3
1/4	28	3.150	0.669	1.181	0.255	0.191	0.2165	.5043	●	3	●	3	●	3	●	3
5/16	24	3.543	0.669	1.260	0.318	0.238	0.2717	.5044	●	3	●	3	●	3	●	3
3/8	24	3.937	0.709	1.535	0.381	0.286	0.3346	.5045	●	4	●	4	●	3	●	3

Reduced Shank

Nominal Size ø d ₁	T.P.I.	l ₁	l ₂	inch		□	Tool Identification		CU497300		CU499300		CU533200		CU539300	
				l ₃	ø d ₂		Rekord 2B-MULTI NT2	Flutes	Rekord 2B-MULTI TICN	Flutes	Enorm 2-MULTI NE2	Flutes	Enorm 2-MULTI TICN	Flutes		
7/16	20	3.937	0.866	—	0.323	0.242	0.3898	.5046	●	3	●	3	●	3	●	3
1/2	20	3.937	0.866	—	0.367	0.275	0.4528	.5047	●	3	●	3	●	4	●	4
9/16	18	3.937	0.866	—	0.429	0.322	0.5118	.5048	●	3	●	3	●	4	●	4
5/8	18	3.937	0.866	—	0.480	0.360	0.5709	.5049	●	3	●	3	●	4	●	4
3/4	16	4.331	0.984	—	0.590	0.442	0.6890	.5050	●	4	●	4	●	4	●	4
7/8	14	4.921	1.024	—	0.697	0.523	0.8071	.5051	●	4	●	4	●	4	●	4
1	12	5.512	1.102	—	0.800	0.600	0.9219	.5052	●	4	●	4	●	4	●	4

Extra Length • ANSI Shank



MULTI
Wide Material
Range



With extra long shank

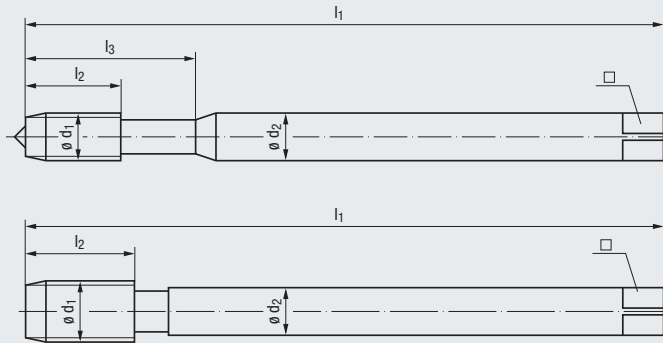

Reinforced Shank
(No.6 - 3/8)

Reduced Shank
(7/16 - 5/8)

UNF

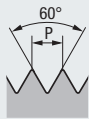

**Unified Fine Thread
ASME B1.1**

Class of Fit
Coating
Cutting Material
Technical Characteristics

2B	2B
NT2	NE2
HSS Extra	HSS Extra
B / 4-5	C / 2-3
E / O / P	E / O / P

Thread Depth
and Hole Shape



Applications – Material

P 1.1-4.1	P 1.1-4.1
M 1.1-2.1	M 1.1-2.1
K 1.1, 2.1	K 1.1, 2.1
K 3.1, 4.1	K 3.1, 4.1
N 1.1-1.4, 2.1-5	N 1.1-1.4, 2.1-5

Reinforced Shank

Nominal Size ø d ₁	T.P.I.	l ₁	l ₂	inch l ₃	ø d ₂	□	Tool Identification		BU797300		BU783200	
							Rekord 1B-MULTI LS-NT2	Flutes	Enorm 1-MULTI LS-NE2	Flutes		
No. 6	40	4.409	0.472	0.787	0.141	0.110	0.1181	.5039	●	3	●	3
No. 8	36	4.921	0.512	0.827	0.168	0.131	0.1378	.5040	●	3	●	3
No. 10	32	5.512	0.512	0.984	0.194	0.152	0.1614	.5041	●	3	●	3
1/4	28	6.299	0.669	1.181	0.255	0.191	0.2165	.5043	●	3	●	3
5/16	24	7.087	0.669	1.260	0.318	0.238	0.2717	.5044	●	3	●	3
3/8	24	7.087	0.709	1.535	0.381	0.286	0.3346	.5045	●	4	●	3

Reduced Shank

Nominal Size ø d ₁	T.P.I.	l ₁	l ₂	inch l ₃	ø d ₂	□	Tool Identification		CU797300		CU783200	
							Rekord 2B-MULTI LS-NT2	Flutes	Enorm 2-MULTI LS-NE2	Flutes		
7/16	20	7.874	0.866	—	0.323	0.242	0.3898	.5046	●	3	●	3
1/2	20	7.874	0.866	—	0.367	0.275	0.4528	.5047	●	3	●	4
5/8	18	7.874	0.866	—	0.480	0.360	0.5709	.5049	●	3	●	4

● = In stock
★ = Allow 7 days for delivery

- Product Finder
- V_c
- UNC
- UNF
- M

DIN Length - ANSI Shank

Overall length acc. to DIN 371, DIN 376

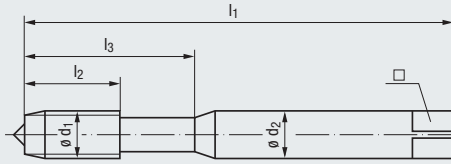

Reinforced Shank (M4 - M10)

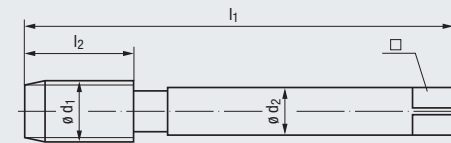

Reduced Shank (M12 - M24)

MULTI

Wide Material Range



M

**ISO Metric Coarse Thread
DIN 13**

Class of Fit
Coating
Cutting Material
Technical Characteristics

ISO 2/6H	ISO 2/6H	ISO 2/6H	ISO 2/6H
NT2	TICN	NE2	TICN
HSS Extra	HSS Extra	HSS Extra	HSS Extra
B / 4-5	B / 4-5	C / 2-3	C / 2-3
E / O / P	E / O / P	E / O / P	E / O / P

Thread Depth and Hole Shape



Applications - Material

P 1.1-4.1	P 1.1-4.1	P 1.1-4.1	P 1.1-4.1
M 1.1-2.1	M 1.1-2.1	M 1.1-2.1	M 1.1-2.1
K 1.1, 2.1	K 1.1, 2.1	K 1.1, 2.1	K 1.1, 2.1
K 3.1, 4.1	K 3.1, 4.1	K 3.1, 4.1	K 3.1, 4.1
N 1.1-1.4, 2.1-5	N 1.1-1.4, 2.1-5	N 1.1-1.4, 2.1-5	N 1.1-1.4, 2.1-5

Reinforced Shank

								Tool Identification		BU497300		BU499300		BU533200		BU539300	
Nominal Size ø d ₁	P mm	l ₁	l ₂	inch l ₃	ø d ₂	□		Dimens. ID	Rekord 1B-MULTI NT2	Flutes	Rekord 1B-MULTI TICN	Flutes	Enorm 1-MULTI NE2	Flutes	Enorm 1-MULTI TICN	Flutes	
									M 4	0.7	2.4803	0.5118	0.8268	0.168	0.131	0.1299	.0040
M 5	0.8	2.7559	0.5906	0.9843	0.194	0.152	0.1654	.0050	●	3	●	3	●	3	●	3	
M 6	1	3.1496	0.6693	1.1811	0.255	0.191	0.1969	.0060	●	3	●	3	●	3	●	3	
M 8	1.25	3.5433	0.7874	1.3780	0.318	0.238	0.2677	.0080	●	3	●	3	●	3	●	3	
M 10	1.5	3.9370	0.8661	1.5354	0.381	0.286	0.3346	.0100	●	3	●	3	●	3	●	3	

Reduced Shank

								Tool Identification		CU497300		CU499300		CU533200		CU539300	
Nominal Size ø d ₁	P mm	l ₁	l ₂	inch l ₃	ø d ₂	□		Dimens. ID	Rekord 2B-MULTI NT2	Flutes	Rekord 2B-MULTI TICN	Flutes	Enorm 2-MULTI NE2	Flutes	Enorm 2-MULTI TICN	Flutes	
									M 12	1.75	4.3307	0.9449	—	0.367	0.275	0.4016	.0112
M 16	2	4.3307	1.0630	—	0.480	0.360	0.5512	.0116	●	3	●	3	●	3	●	3	
M 18	2.5	4.9213	1.1811	—	0.542	0.406	0.6102	.0118	●	3	●	3	●	3	●	3	
M 20	2.5	5.5118	1.2598	—	0.652	0.489	0.6890	.0120	●	3	●	3	●	3	●	3	
M 24	3	6.2992	1.3386	—	0.760	0.570	0.8268	.0124	●	3	●	3	●	4	●	4	

DIN Length • DIN Shank

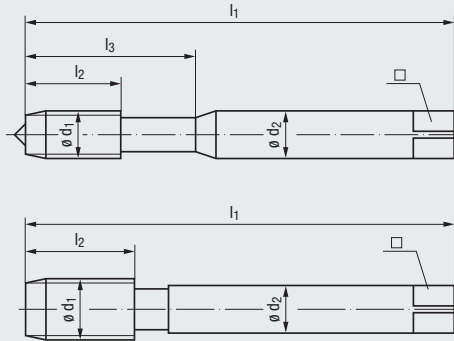

Reinforced Shank
(M4 - M10)

Reduced Shank
(M12 - M24)

M

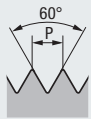

**ISO Metric Coarse Thread
DIN 13**

Class of Fit
Coating
Cutting Material
Technical Characteristics



Thread Depth
and Hole Shape

Applications – Material

MULTI
Wide Material
Range



ISO 2/6H	ISO 2/6H	ISO 2/6H	ISO 2/6H
NT2	TICN	NE2	TICN
HSS Extra	HSS Extra	HSS Extra	HSS Extra
B / 4-5	B / 4-5	C / 2-3	C / 2-3
E / O / P	E / O / P	E / O / P	E / O / P

max. 3 x d₁



max. 2.5 x d₁



P 1.1-4.1	P 1.1-4.1	P 1.1-4.1	P 1.1-4.1
M 1.1-2.1	M 1.1-2.1	M 1.1-2.1	M 1.1-2.1
K 1.1, 2.1	K 1.1, 2.1	K 1.1, 2.1	K 1.1, 2.1
K 3.1, 4.1	K 3.1, 4.1	K 3.1, 4.1	K 3.1, 4.1
N 1.1-1.4, 2.1-5	N 1.1-1.4, 2.1-5	N 1.1-1.4, 2.1-5	N 1.1-1.4, 2.1-5

Reinforced Shank

Nominal Size ø d ₁	P	l ₁	mm			ø d ₂	□	Tool Identification		B1577300		B1579300		B4933200		B4939300	
			l ₂	l ₃	l ₄			Rekord 1B-MULTI NT2	Flutes	Rekord 1B-MULTI TICN	Flutes	Enorm 1-MULTI NE2	Flutes	Enorm 1-MULTI TICN	Flutes		
M 4	0.7	63	13	21	4.5	3.4	3.3	.0040	●	3	●	3	●	3	●	3	
M 5	0.8	70	15	25	6	4.9	4.2	.0050	●	3	●	3	●	3	●	3	
M 6	1	80	17	30	6	4.9	5	.0060	●	3	●	3	●	3	●	3	
M 8	1.25	90	20	35	8	6.2	6.8	.0080	●	3	●	3	●	3	●	3	
M 10	1.5	100	22	39	10	8	8.5	.0100	●	3	●	3	●	3	●	3	

Reduced Shank

Nominal Size ø d ₁	P	l ₁	mm			ø d ₂	□	Tool Identification		C1577300		C1579300		C4933200		C4939300	
			l ₂	l ₃	l ₄			Rekord 2B-MULTI NT2	Flutes	Rekord 2B-MULTI TICN	Flutes	Enorm 2-MULTI NE2	Flutes	Enorm 2-MULTI TICN	Flutes		
M 12	1.75	110	24	—	9	7	10.2	.0112	●	3	●	3	●	3	●	3	
M 16	2	110	27	—	12	9	14	.0116	●	3	●	3	●	3	●	3	
M 18	2.5	125	30	—	14	11	15.5	.0118	●	3	●	3	●	3	●	3	
M 20	2.5	140	32	—	16	12	17.5	.0120	●	3	●	3	●	3	●	3	
M 24	3	160	34	—	18	14.5	21	.0124	●	3	●	3	●	4	●	4	

- Product Finder
- V_c
- UNC
- UNF
- M



● = In stock
★ = Allow 7 days for delivery

- Product Finder
- V_c
- UNC
- UNF
- M

Extra Length • DIN Shank



MULTI
Wide Material
Range

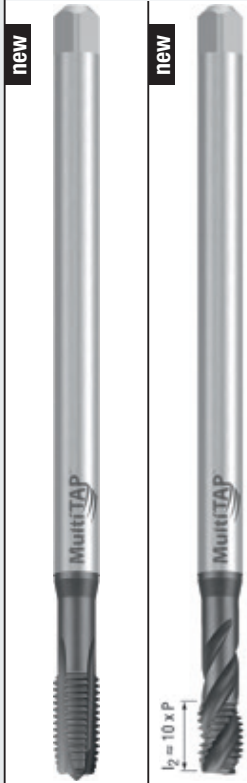

With extra long shank

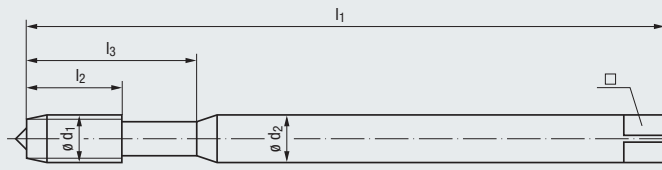

Reinforced Shank
(M3 - M8)

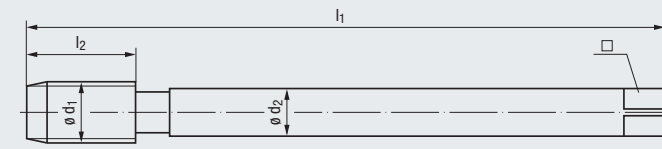

Reduced Shank
(M10 - M20)

M

**ISO Metric Coarse Thread
DIN 13**

Class of Fit	ISO 2/6H	ISO 2/6H
Coating	NT2	NE2
Cutting Material	HSS Extra	HSS Extra
Technical Characteristics	B / 4-5	R35
	E / O / P	C / 2-3
	E / O / P	E / O / P
Thread Depth and Hole Shape	max. 3 x d ₁	max. 2.5 x d ₁

Applications – Material	P 1.1-4.1 M 1.1-2.1 K 1.1, 2.1 K 3.1, 4.1 N 1.1-1.4, 2.1-5	P 1.1-4.1 M 1.1-2.1 K 1.1, 2.1 K 3.1, 4.1 N 1.1-1.4, 2.1-5
-------------------------	---	---

Reinforced Shank

Nominal Size ø d ₁	P	l ₁	l ₂	l ₃	ø d ₂	□
M 3	0.5	100	11	18	3.5	2.7
M 4	0.7	125	13	21	4.5	3.4
M 5	0.8	140	15	25	6	4.9
M 6	1	160	17	30	6	4.9
M 8	1.25	180	20	35	8	6.2

Tool Identification		B1667300		B5863200	
Rekord 1B-MULTI LS-NT2	Flutes	Enorm 1-MULTI LS-NE2	Flutes		
•	3	•	3		
•	3	•	3		
•	3	•	3		
•	3	•	3		
•	3	•	3		

Reduced Shank

Nominal Size ø d ₁	P	l ₁	l ₂	l ₃	ø d ₂	□
M 10	1.5	200	22	—	7	5.5
M 12	1.75	224	24	—	9	7
M 14	2	224	26	—	11	9
M 16	2	224	27	—	12	9
M 18	2.5	250	30	—	14	11
M 20	2.5	280	32	—	16	12

Tool Identification		C1667300		C5863200	
Rekord 2B-MULTI LS-NT2	Flutes	Enorm 2-MULTI LS-NE2	Flutes		
•	3	•	3		
•	3	•	3		
•	3	•	3		
•	3	•	3		
•	3	•	3		
•	3	•	3		

DIN Length • ANSI Shank

Overall length acc. to DIN 2174

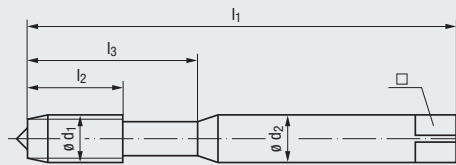

Reinforced Shank
(No.4 - 3/8)

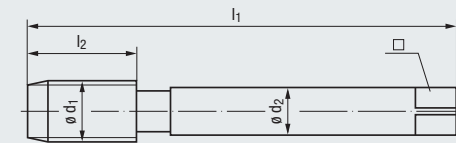

Reduced Shank
(7/16 - 1/2)

UNC

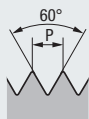

Unified Coarse Thread
ASME B1.1

Class of Fit
Coating
Cutting Material
Technical Characteristics



Thread Depth
and Hole Shape

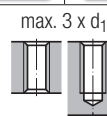

Applications – Material



3BX	3BX
TIN	TICN
HSS Extra	HSS Extra
E / 1.5-2	E / 1.5-2
E / O / P	E / O / P

P 1.1-4.1	P 1.1-4.1
M 1.1-2.1	M 1.1-2.1
N 1.1-1.4, 2.1-5	N 1.1-1.4, 2.1-5

Reinforced Shank

Nominal Size ø d ₁	T.P.I.	l ₁	l ₂	inch		□	Tool Identification		BU591410	BU599010
				l ₃	ø d ₂		Dimens. ID	InnoForm 1-MULTI/E-SN TIN		
No. 4	40	2.205	0.433	0.709	0.141	0.110	0.1004	.5003	●	●
No. 5	40	2.205	0.433	0.709	0.141	0.110	0.1142	.5004	●	●
No. 6	32	2.205	0.472	0.787	0.141	0.110	0.1240	.5005	●	●
No. 8	32	2.480	0.512	0.827	0.168	0.131	0.1496	.5006	●	●
No. 10	24	2.756	0.591	0.984	0.194	0.152	0.1713	.5007	●	●
No. 12	24	3.150	0.630	1.142	0.220	0.165	0.1969	.5008	●	●
1/4	20	3.150	0.669	1.181	0.255	0.191	0.2264	.5009	●	●
5/16	18	3.543	0.787	1.378	0.318	0.238	0.2874	.5010	●	●
3/8	16	3.937	0.866	1.535	0.381	0.286	0.3465	.5011	●	●

Reduced Shank

Nominal Size ø d ₁	T.P.I.	l ₁	l ₂	inch		□	Tool Identification		CU031410	CU039010
				l ₃	ø d ₂		Dimens. ID	InnoForm 2-MULTI/E-SN TIN		
7/16	14	3.937	0.866	—	0.323	0.242	0.4035	.5012	●	●
1/2	13	4.331	0.984	—	0.367	0.275	0.4646	.5013	●	●

We recommend a smaller preparatory diameter by 0.002 in for difficult to form materials (such as aluminum cast alloys) for P = 24 T.P.I. and coarser threads. For further information regarding the recommended preparatory diameters, see page 208 - 209.

● = In stock
★ = Allow 7 days for delivery

Product Finder

V_c

UNC

UNF

M



- Product Finder
- V_c
- UNC
- UNF
- M

DIN Length · ANSI Shank

Overall length acc. to DIN 2174

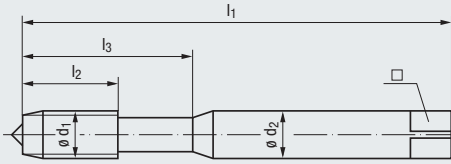

Reinforced Shank
(No. 4 - 3/8)

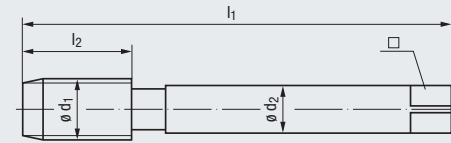

Reduced Shank
(7/16 - 1/2)



UNF

**Unified Fine Thread
ASME B1.1**

Class of Fit
Coating
Cutting Material
Technical Characteristics

3BX	3BX
TIN	TICN
HSS Extra	HSS Extra
E / 1.5-2	E / 1.5-2
E / O / P	E / O / P

Thread Depth and Hole Shape

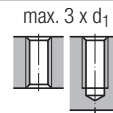

Applications – Material

P 1.1-4.1	P 1.1-4.1
M 1.1-2.1	M 1.1-2.1
N 1.1-1.4, 2.1-5	N 1.1-1.4, 2.1-5

Reinforced Shank

								Tool Identification		BU591410	BU599010
Nominal Size ø d ₁	T.P.I.	l ₁	l ₂	inch		□		Dimens. ID	InnoForm 1-MULTI/E-SN TIN	InnoForm 1-MULTI/E-SN TICN	
				l ₃	ø d ₂						
No. 4	48	2.205	0.433	0.709	0.141	0.110	0.1031	.5037	●	●	
No. 5	44	2.205	0.433	0.709	0.141	0.110	0.1150	.5038	●	●	
No. 6	40	2.205	0.472	0.787	0.141	0.110	0.1268	.5039	●	●	
No. 8	36	2.480	0.512	0.827	0.168	0.131	0.1516	.5040	●	●	
No. 10	32	2.756	0.512	0.984	0.194	0.152	0.1752	.5041	●	●	
No. 12	28	3.150	0.630	1.142	0.220	0.165	0.2008	.5042	●	●	
1/4	28	3.150	0.669	1.181	0.255	0.191	0.2343	.5043	●	●	
5/16	24	3.543	0.669	1.260	0.318	0.238	0.2933	.5044	●	●	
3/8	24	3.937	0.709	1.535	0.381	0.286	0.3563	.5045	●	●	

Reduced Shank

								Tool Identification		CU031410	CU039010
Nominal Size ø d ₁	T.P.I.	l ₁	l ₂	inch		□		Dimens. ID	InnoForm 2-MULTI/E-SN TIN	InnoForm 2-MULTI/E-SN TICN	
				l ₃	ø d ₂						
7/16	20	3.937	0.866	—	0.323	0.242	0.4154	.5046	●	●	
1/2	20	3.937	0.866	—	0.367	0.275	0.4783	.5047	●	●	



We recommend a smaller preparatory diameter by 0.002 in for difficult to form materials (such as aluminum cast alloys) for P = 24 T.P.I. and coarser threads. For further information regarding the recommended preparatory diameters, see page 208 - 209.

DIN Length • DIN Shank

MultiTAP™-Form

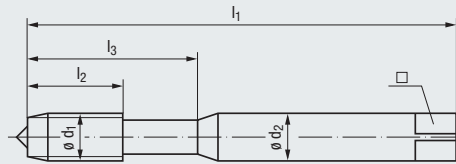

Reinforced Shank

M

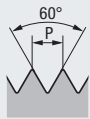

ISO Metric Coarse Thread
DIN 13

Class of Fit
Coating
Cutting Material
Technical Characteristics



Thread Depth
and Hole Shape

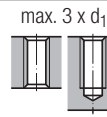

Applications – Material

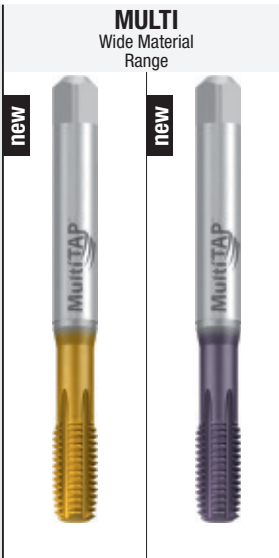

6HX	6HX
TIN	TICN
HSS Extra	HSS Extra
E / 1.5-2	E / 1.5-2
E / O / P	E / O / P

P 1.1-4.1	P 1.1-4.1
M 1.1-2.1	M 1.1-2.1
N 1.1-1.4, 2.1-5	N 1.1-1.4, 2.1-5

Reinforced Shank

Nominal Size ø d ₁	P	l ₁	mm			ø d ₂	□	Tool Identification		InnoForm 1-MULTI/E-SN TIN	InnoForm 1-MULTI/E-SN TICN
			l ₂	l ₃	ø d ₂			□	Dimens. ID		
M 2	0.4	45	7	12	2.8	2.1	1.85	.0020	●	●	
M 3	0.5	56	11	18	3.5	2.7	2.8	.0030	●	●	
M 4	0.7	63	13	21	4.5	3.4	3.7	.0040	●	●	
M 5	0.8	70	15	25	6	4.9	4.65	.0050	●	●	
M 6	1	80	17	30	6	4.9	5.6	.0060	●	●	
M 8	1.25	90	20	35	8	6.2	7.45	.0080	●	●	
M 10	1.5	100	22	39	10	8	9.35	.0100	●	●	

- Product Finder
- V_c
- UNC
- UNF
- M



We recommend a smaller preparatory diameter by 0.05 mm for difficult to form materials (such as aluminum cast alloys) for P ≥ 1 mm. For further information regarding the recommended preparatory diameters, see page 208 - 209.

● = In stock
★ = Allow 7 days for delivery

- Product Finder
- V_c
- UNC
- UNF
- M

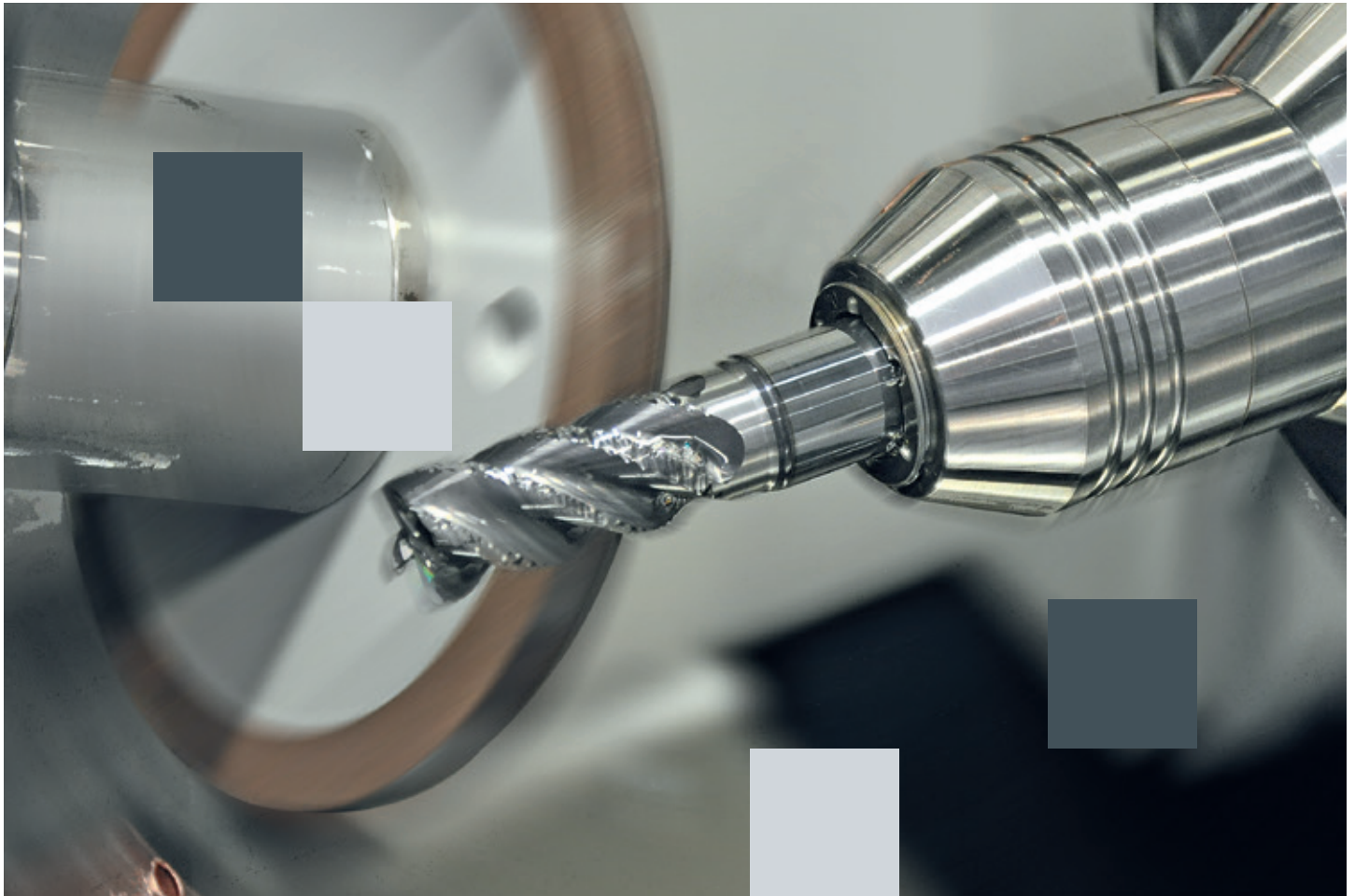

Tool Reconditioning

USA Service Center

Taps – Carbide End Mills – Carbide Drills – Alterations

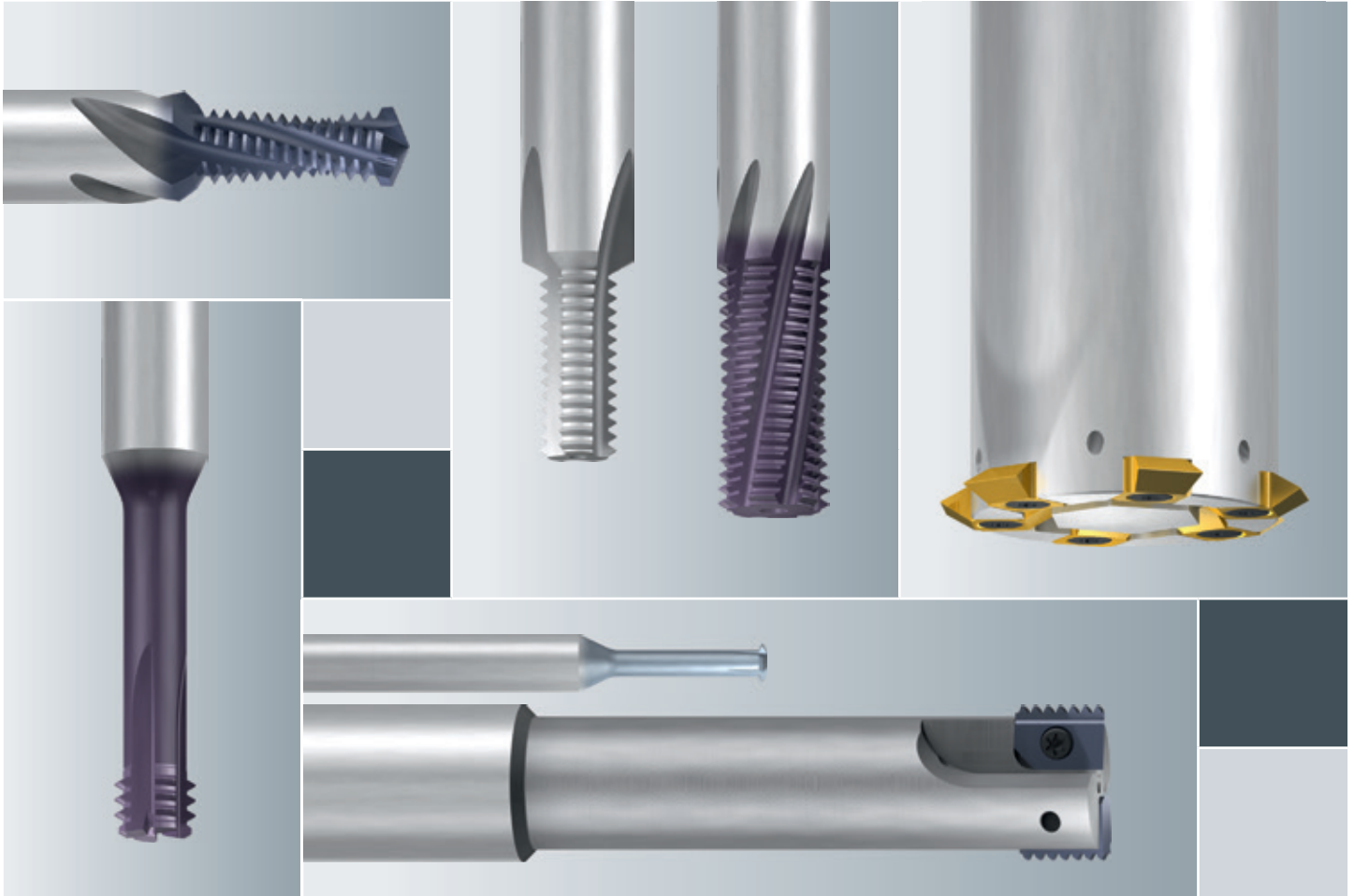

Product Finder

v_c / f_z

UNC

UNF

UN

M

MF

NPSF

Rp (BSPP)

G

W

BSW, BSF

NPT

NPTF

Rc (BSPT)

STI

SELF-LOCK

Accessories

Tech. Info

BGF

ZBGF

GSF (Aero)

GSF-Z

GF(I), GF-Z

GF-Vario-Z

GF-H

GF(I)-KEG

ZGF(I)

CIRC-GF

Gigant

FPC, FMC

MoSys

Thread Mills



Page

Contents	228 - 229
Product Finder and Cutting Data	230 - 234
Product Pages	235 - 352
Technical Information	353 - 362

Product Finder

- v_c / f_z
- UNC
- UNF
- UN
- M
- MF
- NPSF
- Rp (BSPP)
- G
- W
- BSW, BSF
- NPT
- NPTF
- Rc (BSPT)
- STI
- SELF-LOCK
- Accessories
- Tech. Info

BGF

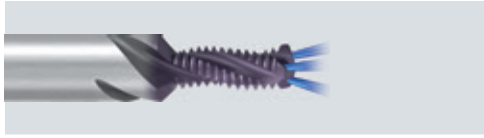

Solid Carbide Drill Thread Mills

- For the complete machining of thread hole, chamfer and thread in one work process
- With corrected thread profile (for one single thread size only)

235 - 242

ZBGF

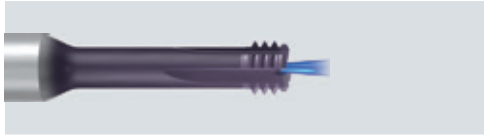

Solid Carbide Circular Drill Thread Mills

- For the machining of thread hole and thread in one work process
- With corrected thread profile (for different thread sizes, but for one pitch only)

243 - 250

GSF, GSF Aero

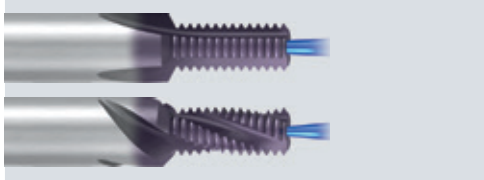

Solid Carbide Thread Mills with Countersinking Step

- For the machining of countersunk edge and thread in one work process
- With corrected thread profile (for one single thread size only)

251 - 261

GSF-Z

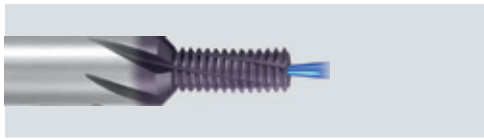

Solid Carbide Thread Mills with Countersinking Step

- For the machining of countersunk edge and thread in one work process
- With corrected thread profile (for one single thread size only)
- Increased number of flutes
- Optimized cutting geometry

GF, GFI



Solid Carbide Thread Mills

- With standard thread profile (for different thread sizes, but for one pitch only)

GF-Z



Solid Carbide Thread Mills

- With standard thread profile (for different thread sizes, but for one pitch only)
- Increased number of flutes
- Optimized cutting geometry

262 - 284

GF-Vario-Z



Solid Carbide Thread Mills, Variable

- With corrected thread profile (for different thread sizes, but for one pitch only)
- Increased number of flutes
- Optimized cutting geometry

GF-H



Solid Carbide Thread Mills for Hard Machining

- With corrected thread profile (for one single thread size only)

GF-KEG, GFI-KEG, GFI-ECO-KEG



Solid Carbide Thread Mills for Tapered Pipe Threads

- With corrected thread profile (for one single thread size, resp. for one pitch only)

285 - 298

ZGF, ZGFI



Solid Carbide Circular Thread Mills

- With corrected thread profile (for different thread sizes and pitches)
- For the machining of threads from M 1

ZGF-S-CUT

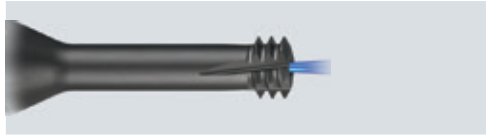

Solid Carbide Circular Thread Mills

- With corrected thread profile (for one single thread size only)

ZGF-HCUT



Solid Carbide Circular Thread Mills

- With corrected thread profile (for one single thread size only)

CIRC-GF

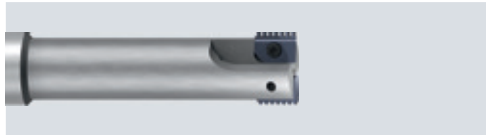

Circular Thread Milling Bodies

- With one or two multi-tooth inserts (for different thread sizes, but for one pitch only)

CIRC-GF



Circular Thread Milling Bodies

- With infeed indexable insert "3-tooth" (for different thread sizes and pitches)

Gigant

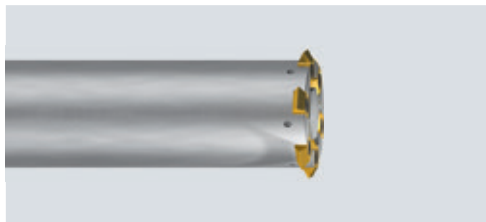

Circular Thread Milling Bodies

- Specially made for large thread sizes
- With up to ten 4-tooth indexable inserts (for different thread sizes and pitches)

FPC



High Precision FPC Milling / Thread Milling / Drilling Chucks

- Increase your machining speed and tool life to the highest possible levels

MoSys

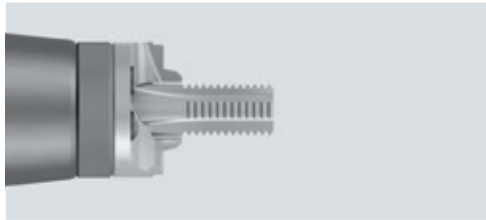

Counterbore and Stepped Bore System for Free Combination

- For the complete machining of thread hole, thread and spot face

299 - 310

311 - 315

316 - 337

338 - 349

350 - 352

v_c / f_z

UNC

UNF

UN

M

MF

NPSF

Rp (BSPP)

G

W

BSW, BSF

NPT

NPTF

Rc (BSPT)

STI

SELF-LOCK

Accessories

Tech. Info

BGF

ZBGF

GSF (Aero)

GSF-Z

GF(I), GF-Z

GF-Vario-Z

GF-H

GF(I)-KEG

ZGF(I)

CIRC-GF

Gigant

FPC, FMC

MoSys

Product finder and cutting data

Please note:

The cutting values listed in the respective columns are standard values which have to be adjusted to individual work conditions (material, lubrication, machine etc.).

The suitability is marked as follows:

- Preferred suitable thread mill
- Suitable thread mill

v_c = Cutting speed [SFM]

f_z = Feed per tooth [inch]

f_b = Drilling feed [inch/rev.]

	Application – Material	Hardness Range			Material Examples
		HRC	BHN	N/mm ²	
P	Steel materials				
	1.1 Cold-extrusion steels, Construction steels, Free-cutting steels, etc.		≤ 180	≤ 600	1010 / 1018 / 1020 / 12L14 / 12L15 / A36 / T1
	2.1 Construction steels, Cementation steels, Steel castings, etc.	≤ 22	≤ 235	≤ 800	A36 / T1 / 1030-1095 / 4140 / 4340 / 8620
	3.1 Cementation steels, Heat-treatable steels, Cold work steels, etc.	≤ 31	≤ 295	≤ 1000	4140 / 4340 / 8620 / P20 / H13 / D2 / A2 / S7 / H1150
	4.1 Heat-treatable steels, Cold work steels, Nitriding steels, etc.	≤ 38	≤ 355	≤ 1200	4140 / 4340 / 8620 / P20 / H13 / D2 / 300M / 52100 / M1-M42
5.1 High-alloyed steels, Cold work steels, Hot work steels, etc.	≤ 44	≤ 415	≤ 1400	4140 / 4340 / 8620 / P20 / H13 / D2 / 300M / 52100	
M	Stainless steel materials				
	1.1 Ferritic, martensitic	≤ 29	≤ 280	≤ 950	410 / 440 / 440C / 17-4 PH
	2.1 Austenitic	≤ 29	≤ 280	≤ 950	303 / 304 / 316 / 316L / 321
	3.1 Austenitic-ferritic (Duplex)	≤ 35	≤ 325	≤ 1100	
4.1 Austenitic-ferritic heat-resistant (Super Duplex)	≤ 39	≤ 370	≤ 1250		
K	Cast materials				
	1.1 Cast iron with lamellar graphite (GJL)		30 - 75	100 - 250	Grey cast irons G10-GG40
	1.2		75 - 135	250 - 450	
	2.1 Cast iron with nodular graphite (GJS)		105 - 150	350 - 500	Nodular GGG40-GGG70
	2.2		150 - 265	500 - 900	
	3.1 Cast iron with vermicular graphite (GJV)		90 - 120	300 - 400	
	3.2		120 - 150	400 - 500	Compact graphite iron (CGI)
4.1 Malleable cast iron (GTMW, GTMB)		70 - 145	250 - 500		
4.2		150 - 235	500 - 800	White iron	
N	Non ferrous materials				
	Aluminum alloys				
	1.1		≤ 60	≤ 200	7075
	1.2 Aluminum wrought alloys		≤ 105	≤ 350	6061-T6 / 2024-T4
	1.3		≤ 165	≤ 550	
	1.4 Aluminum cast alloys Si ≤ 7%				
	1.5 Aluminum cast alloys 7% < Si ≤ 12%				
	1.6 Aluminum cast alloys 12% < Si ≤ 17%				
	Copper alloys				
	2.1 Pure copper, low-alloyed copper		≤ 120	≤ 400	
	2.2 Copper-zinc alloys (brass, long-chipping)		≤ 165	≤ 550	
	2.3 Copper-zinc alloys (brass, short-chipping)		≤ 165	≤ 550	
	2.4 Copper-aluminum alloys (alu bronze, long-chipping)		≤ 235	≤ 800	
	2.5 Copper-tin alloys (tin bronze, long-chipping)		≤ 205	≤ 700	
	2.6 Copper-tin alloys (tin bronze, short-chipping)		≤ 120	≤ 400	
	2.7 Special copper alloys		≤ 180	≤ 600	
	2.8		≤ 44	≤ 415	≤ 1400
	Magnesium alloys				
	3.1 Magnesium wrought alloys		≤ 150	≤ 500	
	3.2 Magnesium cast alloys		≤ 150	≤ 500	
	Synthetics				
	4.1 Duroplastics (short-chipping)				
	4.2 Thermoplastics (long-chipping)				
4.3 Fibre-reinforced synthetics (fibre content ≤ 30%)					
4.4 Fibre-reinforced synthetics (fibre content > 30%)					
Special materials					
5.1 Graphite					
5.2 Tungsten-copper alloys					
5.3 Composite materials					
S	Special materials				
	Titanium alloys				
	1.1 Pure titanium		≤ 135	≤ 450	CP1 / CP2
	1.2 Titanium alloys	≤ 27	≤ 265	≤ 900	6AL4V
	1.3	≤ 39	≤ 370	≤ 1250	
	Nickel alloys, cobalt alloys and iron alloys				
	2.1 Pure nickel		≤ 180	≤ 600	
	2.2 Nickel-base alloys	≤ 31	≤ 295	≤ 1000	Monel 500, 718 Inconel annealed
	2.3	≤ 49	≤ 475	≤ 1600	718 Inconel
	2.4 Cobalt-base alloys	≤ 31	≤ 295	≤ 1000	
	2.5	≤ 49	≤ 475	≤ 1600	Haynes 25
2.6 Iron-base alloys	≤ 46	≤ 445	≤ 1500	Incoloy 925	
H	Hard materials				
	1.1		44 - 50		
	1.2		50 - 55		
	1.3 High strength steels, hardened steels, hard castings		55 - 60		
	1.4		60 - 63		
1.5		63 - 66			

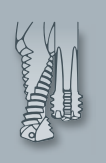

- Product Finder
- v_c / f_z
- UNC
- UNF
- UN
- M
- MF
- NPSF
- Rp (BSPP)
- G
- W
- BSW, BSF
- NPT
- NPTF
- Rc (BSPT)
- STI
- SELF-LOCK
- Accessories
- Tech. Info
- BGF
- ZBGF
- GSF (Aero)
- GSF-Z
- GF(I), GF-Z
- GF-Vario-Z
- GF-H
- GF(I)-KEG
- ZGF(I)
- CIRC-GF
- Gigant
- FPC, FMC
- MoSys



GSF
GSF-Z



GSF Aero



GF
GF-I
GF-Z



GF-Vario-Z



GF-KEG
GF-I-KEG
GF-I-ECO-KEG



CIRC-GF



GF-H

Straight flutes and 15° spiral flutes (R15)		30° Spiral flutes (R30)		f_z			v_c	f_z	
Uncoated	v_c TICN	Uncoated	v_c TICN	$\phi d_1 \leq 0.1575$	$\phi d_1 \leq 0.3150$	$\phi d_1 > 0.3150$	TICN		
131 - 328	262 - 820	131 - 328	262 - 820	.0002 - .0016	.0016 - .0028	.0020 - .0059			1.1
98 - 262	197 - 492	98 - 262	197 - 492	.0002 - .0016	.0016 - .0028	.0020 - .0059			2.1
66 - 197	131 - 394	66 - 197	131 - 394	.0002 - .0012	.0012 - .0020	.0016 - .0047			3.1
66 - 197	131 - 394			.0001 - .0008	.0008 - .0020	.0016 - .0047			4.1
66 - 197	131 - 394			.0001 - .0008	.0008 - .0020	.0016 - .0047			5.1
	131 - 394		131 - 394	.0001 - .0012	.0012 - .0020	.0016 - .0047			1.1
	131 - 394		131 - 394	.0001 - .0012	.0012 - .0020	.0016 - .0047			2.1
	98 - 262			.0001 - .0008	.0008 - .0020	.0016 - .0039			3.1
	98 - 197			.0001 - .0008	.0008 - .0016	.0012 - .0031			4.1
262 - 459	328 - 656	262 - 459	328 - 656		.0016 - .0028	.0020 - .0059			1.1
262 - 459	328 - 656	262 - 459	328 - 656		.0016 - .0028	.0020 - .0059			1.2
197 - 394	262 - 656	197 - 394	262 - 656		.0016 - .0028	.0020 - .0059			2.1
197 - 394	262 - 656	197 - 394	262 - 656		.0016 - .0028	.0020 - .0059			2.2
197 - 394	262 - 656	197 - 394	262 - 656		.0016 - .0028	.0020 - .0059			3.1
197 - 394	262 - 656	197 - 394	262 - 656		.0016 - .0028	.0020 - .0059			3.2
197 - 394	262 - 656	197 - 394	262 - 656		.0016 - .0028	.0020 - .0059			4.1
197 - 394	262 - 656	197 - 394	262 - 656		.0016 - .0028	.0020 - .0059			4.2
328 - 820	492 - 1312	328 - 820	492 - 1312	.0004 - .0020	.0020 - .0031	.0028 - .0079			1.1
328 - 820	492 - 1312	328 - 820	492 - 1312	.0004 - .0020	.0020 - .0031	.0028 - .0079			1.2
328 - 820	492 - 1312	328 - 820	492 - 1312	.0004 - .0020	.0020 - .0031	.0028 - .0079			1.3
492 - 820	492 - 1312	492 - 820	492 - 1312	.0004 - .0020	.0020 - .0031	.0028 - .0079			1.4
492 - 820	492 - 1312	492 - 820	492 - 1312	.0004 - .0020	.0020 - .0031	.0028 - .0079			1.5
	328 - 656		328 - 656	.0004 - .0020	.0020 - .0031	.0028 - .0079			1.6
328 - 820	492 - 1312	328 - 820	492 - 1312	.0003 - .0020	.0020 - .0031	.0028 - .0079			2.1
328 - 820	492 - 1312	328 - 820	492 - 1312	.0003 - .0020	.0020 - .0031	.0028 - .0079			2.2
328 - 820	492 - 1312	328 - 820	492 - 1312	.0003 - .0020	.0020 - .0031	.0028 - .0079			2.3
197 - 492	328 - 820	197 - 492	328 - 820	.0003 - .0016	.0016 - .0028	.0020 - .0059			2.4
197 - 492	328 - 820	197 - 492	328 - 820	.0003 - .0016	.0016 - .0028	.0020 - .0059			2.5
262 - 656	328 - 820	262 - 656	328 - 820	.0003 - .0016	.0016 - .0028	.0020 - .0059			2.6
	131 - 262		131 - 262	.0001 - .0008	.0008 - .0020	.0016 - .0059	131 - 197	.0003 - .0012	2.7
	98 - 197			.0001 - .0008	.0008 - .0020	.0016 - .0059	131 - 197	.0003 - .0012	2.8
492 - 820	492 - 1312	492 - 820	492 - 1312	.0004 - .0020	.0020 - .0031	.0028 - .0079			3.1
492 - 820	492 - 1312	492 - 820	492 - 1312	.0004 - .0020	.0020 - .0031	.0028 - .0079			3.2
197 - 492	328 - 1312	197 - 492	328 - 1312	.0004 - .0020	.0020 - .0039	.0031 - .0098			4.1
197 - 492	328 - 1312	197 - 492	328 - 1312	.0004 - .0020	.0020 - .0039	.0031 - .0098			4.2
	262 - 394		262 - 394	.0004 - .0020	.0020 - .0039	.0031 - .0098			4.3
	262 - 394		262 - 394	.0004 - .0020	.0020 - .0039	.0031 - .0098			4.4
	328 - 656		328 - 656		.0016 - .0028	.0031 - .0098			5.1
49 - 131	98 - 197	49 - 131	98 - 197		.0008 - .0016	.0012 - .0031			5.2
									5.3
49 - 164	98 - 262	49 - 164	98 - 262	.0001 - .0012	.0012 - .0020	.0016 - .0039			1.1
49 - 164	98 - 262	49 - 164	98 - 262	.0001 - .0012	.0012 - .0020	.0016 - .0039			1.2
49 - 131	98 - 197			.0001 - .0008	.0008 - .0016	.0012 - .0031			1.3
	98 - 197		98 - 197	.0001 - .0008	.0008 - .0016	.0012 - .0031			2.1
	98 - 197			.0001 - .0008	.0008 - .0016	.0012 - .0031			2.2
	98 - 131			.0001 - .0008	.0008 - .0016	.0012 - .0031			2.3
	98 - 197			.0001 - .0008	.0008 - .0016	.0012 - .0031			2.4
	98 - 131			.0001 - .0008	.0008 - .0016	.0012 - .0031			2.5
	98 - 131			.0001 - .0008	.0008 - .0016	.0012 - .0031			2.6
	98 - 197				.0006 - .0016	.0012 - .0031			1.1
	98 - 197				.0006 - .0016	.0012 - .0031			1.2
							131 - 197	.0002 - .0010	1.3
							98 - 131	.0002 - .0006	1.4
							98 - 131	.0002 - .0006	1.5

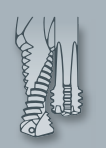

BGF-Z2



BGF-Z3

	v_c		v_c		f_b		f_z		
	Uncoated	TICN	Uncoated	TICN	$\varnothing d_1 \leq 0.3150$	$\varnothing d_1 > 0.3150$	$\varnothing d_1 \leq 0.3150$	$\varnothing d_1 > 0.3150$	
P	1.1								
	2.1								
	3.1								
	4.1								
	5.1								
M	1.1								
	2.1								
	3.1								
	4.1								
K	1.1	262 - 459	262 - 525	262 - 459	262 - 525	.0039 - .0098	.0079 - .0157	.0016 - .0028	.0020 - .0047
	1.2	262 - 459	262 - 525	262 - 459	262 - 525	.0039 - .0098	.0079 - .0157	.0016 - .0028	.0020 - .0047
	2.1	262 - 459	262 - 525			.0039 - .0059	.0059 - .0098	.0016 - .0028	.0020 - .0047
	2.2	262 - 459	262 - 525			.0039 - .0059	.0059 - .0098	.0016 - .0028	.0020 - .0047
	3.1	262 - 459	262 - 525			.0039 - .0098	.0079 - .0157	.0016 - .0028	.0020 - .0047
	3.2	262 - 459	262 - 525			.0039 - .0098	.0079 - .0157	.0016 - .0028	.0020 - .0047
	4.2								
N	1.1	328 - 820	492 - 820			.0031 - .0059	.0059 - .0098	.0016 - .0031	.0028 - .0059
	1.2	328 - 820	492 - 820			.0031 - .0059	.0059 - .0098	.0016 - .0031	.0028 - .0059
	1.3	328 - 820	492 - 820			.0031 - .0059	.0059 - .0098	.0016 - .0031	.0028 - .0059
	1.4	328 - 820	492 - 1312			.0059 - .0098	.0079 - .0157	.0016 - .0031	.0028 - .0059
	1.5	328 - 820	492 - 1312	328 - 820	492 - 1312	.0059 - .0098	.0079 - .0157	.0016 - .0031	.0028 - .0059
	1.6		328 - 656		328 - 656	.0059 - .0098	.0079 - .0157	.0016 - .0031	.0028 - .0059
	2.1								
	2.2	328 - 820	492 - 1312			.0039 - .0079	.0059 - .0118	.0020 - .0031	.0028 - .0059
	2.3	328 - 820	492 - 1312	328 - 820	492 - 1312	.0039 - .0079	.0059 - .0118	.0020 - .0031	.0028 - .0059
	2.4								
	2.5								
	2.6	262 - 656	328 - 820			.0039 - .0098	.0079 - .0157	.0016 - .0028	.0020 - .0047
	2.7								
	2.8								
	3.1	328 - 820	492 - 1312			.0039 - .0079	.0059 - .0118	.0016 - .0031	.0028 - .0059
	3.2	328 - 820	492 - 1312			.0059 - .0118	.0079 - .0157	.0016 - .0031	.0028 - .0059
4.1	197 - 492	328 - 1312			.0059 - .0118	.0079 - .0157	.0020 - .0039	.0031 - .0079	
4.2									
4.3									
4.4									
5.1									
5.2									
5.3									
S	1.1								
	1.2								
	1.3								
	2.1								
	2.2								
	2.6								
H	1.1								
	1.2								
	1.3								
	1.4								
	1.5								



ZGF
ZGFI



ZGF-S-CUT



ZGF-HCUT

	v_c		f_z			v_c		f_z
	Uncoated	TICN	$\varnothing d_1 \leq 0.1575$	$\varnothing d_1 \leq 0.3150$	$\varnothing d_1 > 0.3150$	TICN		
131 - 328		262 - 820	.0002 - .0016	.0016 - .0028	.0020 - .0059			1.1
98 - 262		197 - 492	.0002 - .0016	.0016 - .0028	.0020 - .0059			2.1
66 - 197		131 - 394	.0002 - .0012	.0012 - .0020	.0016 - .0047			3.1
66 - 197		131 - 394	.0001 - .0008	.0008 - .0020	.0016 - .0047			4.1
66 - 197		131 - 394	.0001 - .0008	.0008 - .0020	.0016 - .0047			5.1
		131 - 394	.0001 - .0012	.0012 - .0020	.0016 - .0047			1.1
		131 - 394	.0001 - .0012	.0012 - .0020	.0016 - .0047			2.1
		98 - 262	.0001 - .0008	.0008 - .0020	.0016 - .0039			3.1
		98 - 197	.0001 - .0008	.0008 - .0016	.0012 - .0031			4.1
262 - 459		328 - 656		.0016 - .0028	.0020 - .0059			1.1
262 - 459		328 - 656		.0016 - .0028	.0020 - .0059			1.2
197 - 394		262 - 656		.0016 - .0028	.0020 - .0059			2.1
197 - 394		262 - 656		.0016 - .0028	.0020 - .0059			2.2
197 - 394		262 - 656		.0016 - .0028	.0020 - .0059			3.1
197 - 394		262 - 656		.0016 - .0028	.0020 - .0059			3.2
197 - 394		262 - 656		.0016 - .0028	.0020 - .0059			4.1
197 - 394		262 - 656		.0016 - .0028	.0020 - .0059			4.2
		328 - 820	.0004 - .0020	.0020 - .0031	.0028 - .0079			1.1
		328 - 820	.0004 - .0020	.0020 - .0031	.0028 - .0079			1.2
		328 - 820	.0004 - .0020	.0020 - .0031	.0028 - .0079			1.3
		492 - 820	.0004 - .0020	.0020 - .0031	.0028 - .0079			1.4
492 - 820		492 - 1312	.0004 - .0020	.0020 - .0031	.0028 - .0079			1.5
		328 - 656	.0004 - .0020	.0020 - .0031	.0028 - .0079			1.6
328 - 820		492 - 1312	.0003 - .0020	.0020 - .0031	.0028 - .0079			2.1
328 - 820		492 - 1312	.0003 - .0020	.0020 - .0031	.0028 - .0079			2.2
328 - 820		492 - 1312	.0003 - .0020	.0020 - .0031	.0028 - .0079			2.3
197 - 492		328 - 820	.0003 - .0016	.0016 - .0028	.0020 - .0059			2.4
197 - 492		328 - 820	.0003 - .0016	.0016 - .0028	.0020 - .0059			2.5
262 - 656		328 - 820	.0003 - .0016	.0016 - .0028	.0020 - .0059			2.6
		131 - 262	.0001 - .0008	.0008 - .0020	.0016 - .0059			2.7
		98 - 197	.0001 - .0008	.0008 - .0020	.0016 - .0059			2.8
492 - 820		492 - 1312	.0004 - .0020	.0020 - .0031	.0028 - .0079			3.1
492 - 820		492 - 1312	.0004 - .0020	.0020 - .0031	.0028 - .0079			3.2
		197 - 492	.0004 - .0020	.0020 - .0039	.0031 - .0098			4.1
		197 - 492	.0004 - .0020	.0020 - .0039	.0031 - .0098			4.2
		262 - 394	.0004 - .0020	.0020 - .0039	.0031 - .0098			4.3
		262 - 394	.0004 - .0020	.0020 - .0039	.0031 - .0098			4.4
		328 - 656		.0016 - .0028	.0031 - .0098			5.1
49 - 131		98 - 197		.0008 - .0016	.0012 - .0031			5.2
								5.3
49 - 164		98 - 262	.0001 - .0012	.0012 - .0020	.0016 - .0039			1.1
49 - 164		98 - 262	.0001 - .0012	.0012 - .0020	.0016 - .0039			1.2
49 - 131		98 - 197	.0001 - .0008	.0008 - .0016	.0012 - .0031			1.3
		98 - 197	.0001 - .0008	.0008 - .0016	.0012 - .0031			2.1
		98 - 197	.0001 - .0008	.0008 - .0016	.0012 - .0031			2.2
		98 - 131	.0001 - .0008	.0008 - .0016	.0012 - .0031			2.3
		98 - 197	.0001 - .0008	.0008 - .0016	.0012 - .0031			2.4
		98 - 131	.0001 - .0008	.0008 - .0016	.0012 - .0031			2.5
		98 - 131	.0001 - .0008	.0008 - .0016	.0012 - .0031			2.6
		98 - 197		.0006 - .0016	.0012 - .0031	98 - 197	.0002 - .0031	1.1
		98 - 197		.0006 - .0016	.0012 - .0031	98 - 197	.0002 - .0031	1.2
						98 - 197	.0002 - .0024	1.3
						98 - 197	.0002 - .0024	1.4
						98 - 197	.0002 - .0024	1.5



ZBGF-T



ZBGF-W



ZBGF-H



Gigant

		v_c Coated	f_z	v_c Coated	f_z	v_c Coated	f_z	v_c Coated	f_z
P	1.1			492 - 820	.0016 - .0031			820 - 1640	.0059 - .0098
	2.1			492 - 820	.0016 - .0031			820 - 1640	.0059 - .0098
	3.1			328 - 820	.0012 - .0031			492 - 820	.0039 - .0059
	4.1			328 - 820	.0012 - .0031			492 - 820	.0039 - .0059
	5.1			328 - 656	.0008 - .0024			492 - 820	.0039 - .0059
M	1.1			328 - 591	.0008 - .0020			262 - 492	.0039 - .0059
	2.1			328 - 591	.0008 - .0020			262 - 492	.0039 - .0059
	3.1			197 - 394	.0008 - .0016			197 - 394	.0031 - .0047
	4.1			197 - 394	.0008 - .0016			197 - 394	.0031 - .0047
K	1.1	656 - 984	.0016 - .0047	656 - 984	.0016 - .0039			591 - 1312	.0059 - .0098
	1.2	656 - 984	.0016 - .0047	656 - 984	.0016 - .0039			591 - 1312	.0059 - .0098
	2.1			492 - 820	.0020 - .0031			591 - 1312	.0059 - .0098
	2.2			492 - 820	.0020 - .0031			591 - 1312	.0059 - .0098
	3.1			492 - 820	.0020 - .0031			492 - 820	.0039 - .0059
	3.2			492 - 820	.0020 - .0031			492 - 820	.0039 - .0059
	4.1			656 - 984	.0020 - .0039			591 - 1312	.0059 - .0098
	4.2			656 - 984	.0020 - .0039			591 - 1312	.0059 - .0098
N	1.1	656 - 984	.0016 - .0031	656 - 984	.0020 - .0039			1312 - 1640	.0059 - .0118
	1.2	656 - 984	.0016 - .0031	656 - 984	.0020 - .0039			1312 - 1640	.0059 - .0118
	1.3	656 - 984	.0016 - .0031	656 - 984	.0020 - .0039			1312 - 1640	.0059 - .0118
	1.4	656 - 984	.0016 - .0031	656 - 984	.0020 - .0039			1312 - 1640	.0059 - .0118
	1.5	656 - 984	.0016 - .0039	656 - 984	.0020 - .0039			1312 - 1640	.0059 - .0118
	1.6	328 - 656	.0016 - .0039	328 - 656	.0020 - .0039			492 - 820	.0059 - .0118
	2.1			328 - 591	.0012 - .0020			820 - 1640	.0059 - .0098
	2.2			492 - 820	.0020 - .0031			820 - 1640	.0059 - .0098
	2.3			656 - 984	.0020 - .0039			820 - 1640	.0059 - .0098
	2.4			328 - 591	.0012 - .0020			492 - 820	.0039 - .0098
	2.5			328 - 591	.0012 - .0020			492 - 820	.0039 - .0098
	2.6			656 - 984	.0020 - .0039			492 - 820	.0039 - .0098
	2.7					131 - 197	.0008 - .0016	262 - 492	.0039 - .0059
	2.8					131 - 197	.0008 - .0016	262 - 492	.0039 - .0059
	3.1	656 - 984	.0016 - .0039	656 - 984	.0020 - .0039			1312 - 1640	.0059 - .0118
	3.2	656 - 984	.0016 - .0039	656 - 984	.0020 - .0039			1312 - 1640	.0059 - .0118
4.1			492 - 820	.0020 - .0031			591 - 1312	.0059 - .0098	
4.2			492 - 820	.0020 - .0031			591 - 1312	.0059 - .0098	
4.3			262 - 492	.0020 - .0031			262 - 492	.0059 - .0098	
4.4			262 - 492	.0020 - .0031			262 - 492	.0059 - .0098	
5.1									
5.2									
5.3									
S	1.1			197 - 394	.0008 - .0016			197 - 394	.0031 - .0047
	1.2			197 - 394	.0008 - .0016			197 - 394	.0031 - .0047
	1.3			197 - 394	.0008 - .0016			197 - 394	.0031 - .0047
	2.1			197 - 394	.0008 - .0016				
	2.2			197 - 394	.0008 - .0016				
	2.3			197 - 394	.0008 - .0016				
2.4			197 - 394	.0008 - .0016					
2.5									
2.6									
H	1.1			197 - 328	.0008 - .0024	197 - 328	.0012 - .0024		
	1.2			197 - 328	.0008 - .0024	197 - 328	.0012 - .0024		
	1.3					131 - 230	.0008 - .0016		
	1.4					98 - 197	.0008 - .0016		
	1.5					98 - 197	.0008 - .0016		

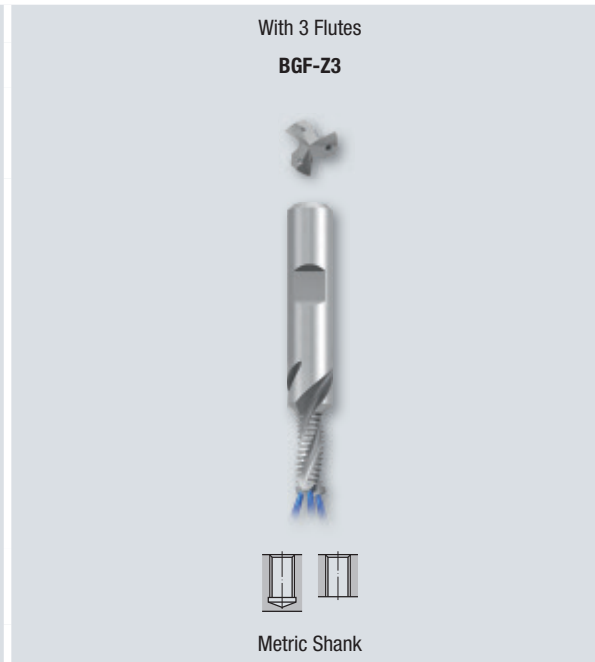
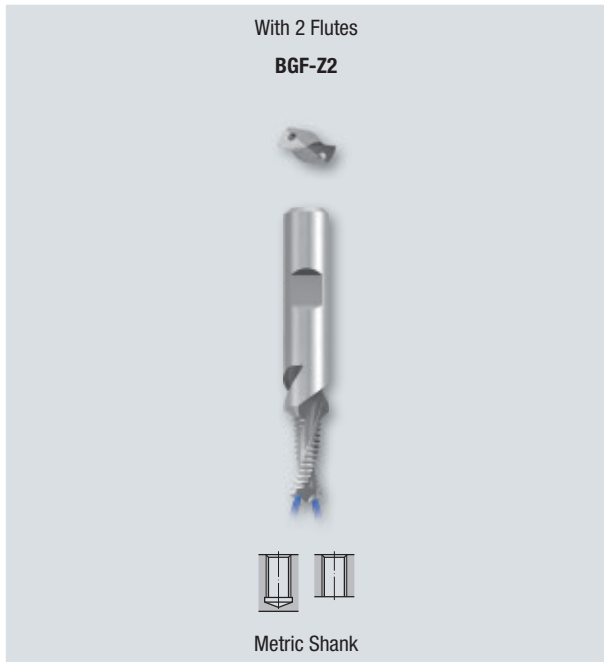

Page

236	
237	
238	239
240	
241	

UNC
UNF
M
MF
STI-M

Product Finder

v_c / f_z

UNC

UNF

UN

M

MF

NPSF

Rp (BSPP)

G

W

BSW, BSF

NPT

NPTF

Rc (BSPT)

STI

SELF-LOCK

Accessories

Tech. Info

BGF

ZBGF

GSF (Aero)

GSF-Z

GF(I), GF-Z

GF-Vario-Z

GF-H

GF(I)-KEG

ZGF(I)

CIRC-GF

Gigant

FPC, FMC

MoSys

Possible modifications

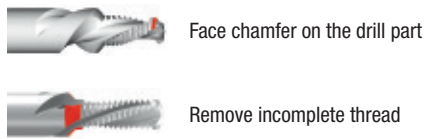

For a description of these modifications, see page 357

Thread milling cycle

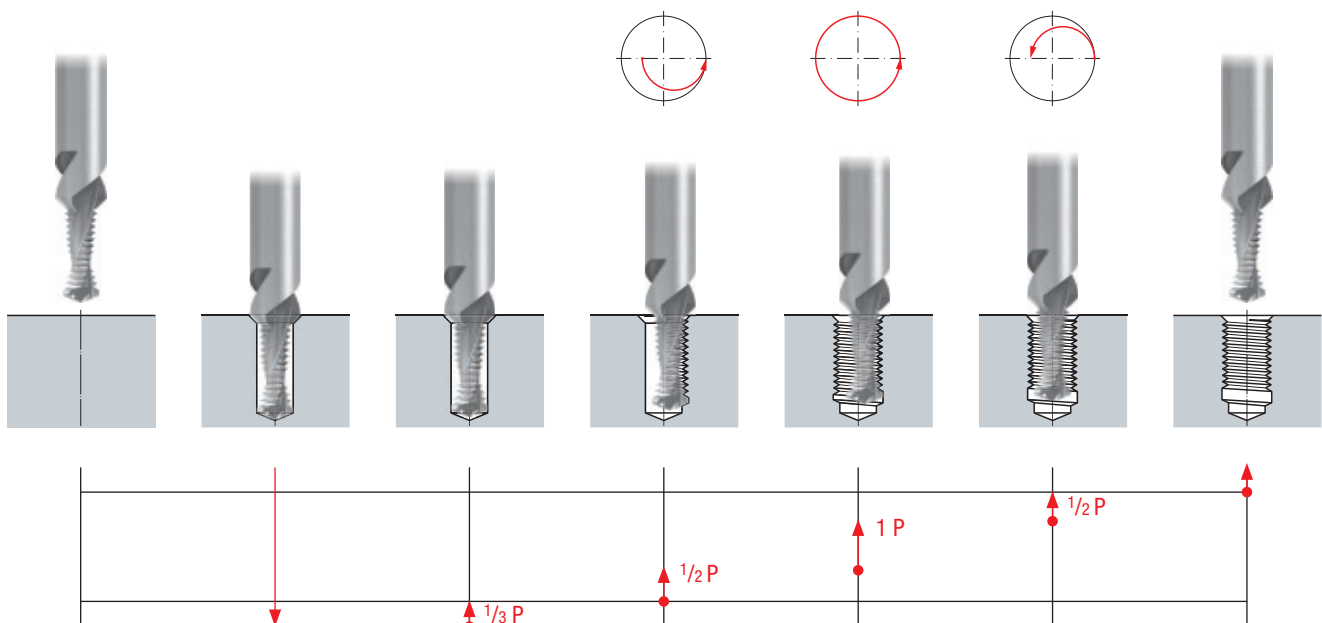

- Product Finder
- v_c / f_z
- UNC
- UNF
- UN
- M
- MF
- NPSF
- Rp (BSPP)
- G
- W
- BSW, BSF
- NPT
- NPTF
- Rc (BSPT)
- STI
- SELF-LOCK
- Accessories
- Tech. Info

Metric Shank

Carbide

R30

RH + LH

2 Flutes

DIN 6535

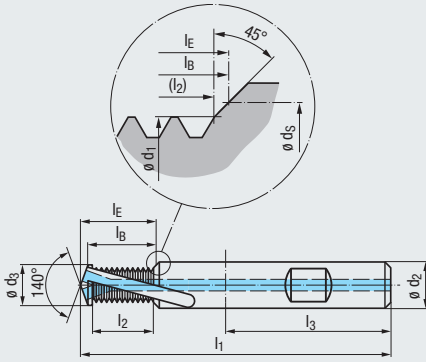

Coating

TICN

Applications – Material

K 1.1-3.2	N 1.1-5	K 1.1-3.2	N 1.1-6
N 2.2-3, 2.6	N 3.1-2, 4.1	N 2.2-3, 2.6	N 3.1-2, 4.1

UNC



Unified Coarse Thread
ASME B1.1

Thread Depth

1.5 x D

Tool Identification

GF422201

GF422206

Nominal Size	T.P.I.	l_1	l_2	l_3	inch					Ø d ₂		Dimens. ID	BGF-VHM-Z2 1.5xD R30-1KZ-HB	BGF-VHM-Z2 1.5xD R30-1KZ-HB TICN
					Ø d ₁	Ø d ₃	Ø d _S	l_B	l_E	inch	mm			
No. 12	24	2.441	0.295	1.417	0.166	0.177	0.228	0.362	0.394	0.315	8	.5008		
1/4	20	2.441	0.354	1.417	0.191	0.205	0.262	0.437	0.472	0.315	8	.5009	●	●
5/16	18	2.913	0.448	1.575	0.246	0.260	0.325	0.539	0.587	0.394	10	.5010	●	●
3/8	16	3.110	0.567	1.772	0.301	0.315	0.387	0.665	0.724	0.472	12	.5011	●	●
7/16	14	3.110	0.648	1.772	0.354	0.370	0.450	0.760	0.827	0.472	12	.5012	●	●
1/2	13	3.504	0.697	1.772	0.407	0.423	0.512	0.819	0.898	0.551	14	.5013	●	●
9/16	12	4.016	0.839	1.890	0.465	0.482	0.575	0.972	1.059	0.630	16	.5014	●	●
5/8	11	4.016	0.914	1.890	0.516	0.531	0.637	1.059	1.154	0.709	18	.5015	●	●
3/4	10	4.528	1.106	1.969	0.630	0.650	0.762	1.264	1.382	0.787	20	.5016	●	●

Thread Depth

2 x D

Tool Identification

GF432201

GF432206

Nominal Size	T.P.I.	l_1	l_2	l_3	inch					Ø d ₂		Dimens. ID	BGF-VHM-Z2 2xD R30-1KZ-HB	BGF-VHM-Z2 2xD R30-1KZ-HB TICN
					Ø d ₁	Ø d ₃	Ø d _S	l_B	l_E	inch	mm			
No. 12	24	2.441	0.420	1.417	0.166	0.177	0.228	0.488	0.520	0.315	8	.5008		
1/4	20	2.441	0.504	1.417	0.191	0.205	0.262	0.587	0.622	0.315	8	.5009	●	●
5/16	18	2.913	0.615	1.575	0.246	0.260	0.325	0.705	0.752	0.394	10	.5010	●	●
3/8	16	3.110	0.754	1.772	0.301	0.315	0.387	0.854	0.913	0.472	12	.5011	●	●
7/16	14	3.110	0.862	1.772	0.354	0.370	0.450	0.976	1.043	0.472	12	.5012	●	●
1/2	13	3.504	1.005	1.772	0.407	0.423	0.512	1.126	1.205	0.551	14	.5013	●	●
9/16	12	4.016	1.089	1.890	0.465	0.482	0.575	1.220	1.307	0.630	16	.5014	●	●
5/8	11	4.016	1.187	1.890	0.516	0.531	0.637	1.331	1.425	0.709	18	.5015	●	●
3/4	10	4.528	1.506	1.969	0.630	0.650	0.762	1.661	1.780	0.787	20	.5016	●	●

Thread Depth

2.5 x D

Tool Identification

GF442201

GF442206

Nominal Size	T.P.I.	l_1	l_2	l_3	inch					Ø d ₂		Dimens. ID	BGF-VHM-Z2 2.5xD R30-1KZ-HB	BGF-VHM-Z2 2.5xD R30-1KZ-HB TICN
					Ø d ₁	Ø d ₃	Ø d _S	l_B	l_E	inch	mm			
3/8	16	3.346	0.942	1.772	0.301	0.315	0.387	1.043	1.098	0.472	12	.5011	●	●
7/16	14	3.346	1.076	1.772	0.354	0.370	0.450	1.189	1.256	0.472	12	.5012	●	●
1/2	13	3.740	1.236	1.772	0.407	0.423	0.512	1.358	1.437	0.551	14	.5013	●	●
9/16	12	4.331	1.339	1.890	0.465	0.482	0.575	1.469	1.559	0.630	16	.5014	●	●
5/8	11	4.331	1.550	1.890	0.516	0.531	0.637	1.693	1.791	0.709	18	.5015	●	●
3/4	10	4.921	1.806	1.969	0.630	0.650	0.762	1.965	2.083	0.787	20	.5016	●	●

Metric Shank

Carbide

R30 RH + LH

2 Flutes

DIN 6535

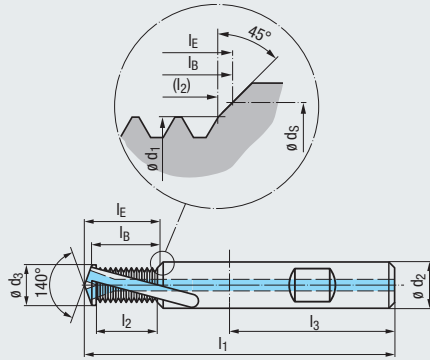
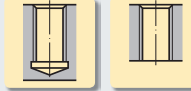
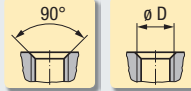

UNF



Unified Fine Thread ASME B1.1

Coating

TICN

Applications – Material

K 1.1-3.2	N 1.1-5	K 1.1-3.2	N 1.1-6
N 2.2-3, 2.6	N 3.1-2, 4.1	N 2.2-3, 2.6	N 3.1-2, 4.1

Thread Depth

1.5 x D

Tool Identification

GF422201

GF422206

Nominal Size ø D	T.P.I.	l ₁	l ₂	l ₃	inch			l _B	l _E	ø d ₂		Dimens. ID	BGF-VHM-Z2 1.5xD R30-IKZ-HB	BGF-VHM-Z2 1.5xD R30-IKZ-HB TICN
					ø d ₁	ø d ₃	ø d _S			inch	mm			
No. 10	32	2.165	0.285	1.417	0.150	0.161	0.203	0.339	0.366	0.236	6	.5041		
No. 12	28	2.441	0.326	1.417	0.172	0.183	0.228	0.386	0.417	0.315	8	.5042		
1/4	28	2.441	0.361	1.417	0.207	0.217	0.262	0.417	0.457	0.315	8	.5043	●	●
5/16	24	2.913	0.462	1.575	0.260	0.272	0.325	0.531	0.579	0.394	10	.5044	●	●
3/8	24	3.110	0.546	1.772	0.323	0.335	0.388	0.614	0.677	0.472	12	.5045	●	●
7/16	20	3.110	0.705	1.772	0.376	0.390	0.449	0.783	0.854	0.472	12	.5046	●	●
1/2	20	3.504	0.756	1.772	0.437	0.453	0.512	0.835	0.917	0.551	14	.5047	●	●
9/16	18	4.016	0.839	1.890	0.492	0.508	0.575	0.929	1.020	0.630	16	.5048	●	●
5/8	18	4.016	0.895	1.890	0.555	0.571	0.638	0.984	1.087	0.709	18	.5049	●	●
3/4	16	4.528	1.133	1.969	0.669	0.689	0.764	1.232	1.358	0.787	20	.5050	●	●

Thread Depth

2 x D

Tool Identification

GF432201

GF432206

Nominal Size ø D	T.P.I.	l ₁	l ₂	l ₃	inch			l _B	l _E	ø d ₂		Dimens. ID	BGF-VHM-Z2 2xD R30-IKZ-HB	BGF-VHM-Z2 2xD R30-IKZ-HB TICN
					ø d ₁	ø d ₃	ø d _S			inch	mm			
No. 10	32	2.165	0.379	1.417	0.150	0.161	0.203	0.433	0.461	0.236	6	.5041		
No. 12	28	2.441	0.433	1.417	0.172	0.183	0.228	0.492	0.524	0.315	8	.5042		
1/4	28	2.441	0.504	1.417	0.207	0.217	0.262	0.563	0.602	0.315	8	.5043	●	●
5/16	24	2.913	0.629	1.575	0.260	0.272	0.325	0.697	0.748	0.394	10	.5044	●	●
3/8	24	3.110	0.754	1.772	0.323	0.335	0.388	0.823	0.882	0.472	12	.5045	●	●
7/16	20	3.110	0.855	1.772	0.376	0.390	0.449	0.937	1.004	0.472	12	.5046	●	●
1/2	20	3.504	1.006	1.772	0.437	0.453	0.512	1.087	1.169	0.551	14	.5047	●	●
9/16	18	4.016	1.117	1.890	0.492	0.508	0.575	1.205	1.299	0.630	16	.5048	●	●
5/8	18	4.016	1.229	1.890	0.555	0.571	0.638	1.319	1.421	0.709	18	.5049	●	●
3/4	16	4.528	1.508	1.969	0.669	0.689	0.764	1.610	1.736	0.787	20	.5050	●	●

Other sizes upon request

- Product Finder
- v_c / f_z
- UNC
- UNF**
- UN
- M
- MF
- NPSF
- Rp (BSPP)
- G
- W
- BSW, BSF
- NPT
- NPTF
- Rc (BSPT)
- STI
- SELF-LOCK
- Accessories
- Tech. Info

- BGF**
- ZBGF
- GSF (Aero)
- GSF-Z
- GF(I), GF-Z
- GF-Vario-Z
- GF-H
- GF(I)-KEG
- ZGF(I)
- CIRC-GF
- Gigant
- FPC, FMC
- MoSys



- Product Finder
- v_c / f_z
- UNC
- UNF
- UN
- M**
- MF
- NPSF
- Rp (BSPP)
- G
- W
- BSW, BSF
- NPT
- NPTF
- Rc (BSPT)
- STI
- SELF-LOCK
- Accessories
- Tech. Info

Metric Shank

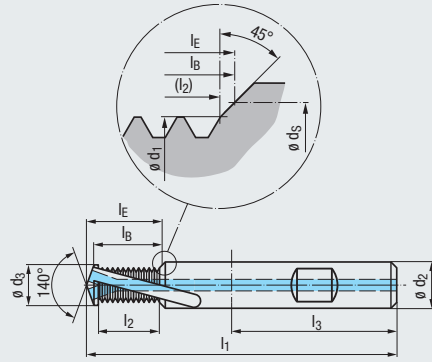

Carbide

R30

RH + LH

2 Flutes

DIN 6535



Coating

TICN

Applications – Material

K	1.1-3.2	N	1.1-5	K	1.1-3.2	N	1.1-6
N	2.2-3, 2.6	N	3.1-2, 4.1	N	2.2-3, 2.6	N	3.1-2, 4.1

M



ISO Metric Coarse Thread DIN 13

Thread Depth

1.5 x D

Tool Identification

GF422201

GF422206

Nominal Size	P mm	l ₁	l ₂	l ₃	mm			l _B	l _E	d ₂	Dimens. ID
					∅ d ₁	∅ d ₃	∅ d _S				
M 4	0.7	49	5.64	36	3.16	3.3	4.3	6.8	7.4	6	.0040
M 5	0.8	55	7.25	36	4.04	4.2	5.3	8.6	9.4	6	.0050
M 6	1	62	9.06	36	4.8	5	6.3	10.7	11.6	8	.0060
M 8	1.25	74	11.33	40	6.5	6.75	8.3	13.4	14.6	10	.0080
M 10	1.5	79	15.09	45	8.2	8.5	10.3	17.5	19.1	12	.0100
M 12	1.75	89	17.61	45	9.9	10.25	12.3	20.4	22.3	14	.0112
M 14	2	102	20.12	48	11.6	12	14.3	23.3	25.5	16	.0114
M 16	2	102	24.13	48	13.6	14	16.3	27.3	29.9	18	.0116

BGF-VHM-Z2
1.5xD
R30-IKZ-HB

BGF-VHM-Z2
1.5xD
R30-IKZ-HB
TICN

M 4	•	•
M 5	•	•
M 6	•	•
M 8	•	•
M 10	•	•
M 12	•	•
M 14	•	•
M 16	•	•

Thread Depth

2 x D

Tool Identification

GF432201

GF432206

Nominal Size	P mm	l ₁	l ₂	l ₃	mm			l _B	l _E	d ₂	Dimens. ID
					∅ d ₁	∅ d ₃	∅ d _S				
M 4	0.7	49	7.74	36	3.16	3.3	4.3	8.9	9.5	6	.0040
M 5	0.8	55	9.65	36	4.04	4.2	5.3	11	11.8	6	.0050
M 6	1	62	12.06	36	4.8	5	6.3	13.7	14.6	8	.0060
M 8	1.25	74	15.08	40	6.5	6.75	8.3	17.1	18.3	10	.0080
M 10	1.5	79	19.59	45	8.2	8.5	10.3	22	23.6	12	.0100
M 12	1.75	89	22.86	45	9.9	10.25	12.3	25.7	27.5	14	.0112
M 14	2	102	28.12	48	11.6	12	14.3	31.3	33.5	16	.0114
M 16	2	102	32.13	48	13.6	14	16.3	35.3	37.9	18	.0116

BGF-VHM-Z2
2xD
R30-IKZ-HB

BGF-VHM-Z2
2xD
R30-IKZ-HB
TICN

M 4	•	•
M 5	•	•
M 6	•	•
M 8	•	•
M 10	•	•
M 12	•	•
M 14	•	•
M 16	•	•

Thread Depth

2.5 x D

Tool Identification

GF442201

GF442206

Nominal Size	P mm	l ₁	l ₂	l ₃	mm			l _B	l _E	d ₂	Dimens. ID
					∅ d ₁	∅ d ₃	∅ d _S				
M 6	1	65	15.10	36	4.8	5	6.3	16.7	17.6	8	.0060
M 8	1.25	80	20.08	40	6.5	6.75	8.3	22.1	23.3	10	.0080
M 10	1.5	85	25.59	45	8.2	8.5	10.3	28	29.6	12	.0100
M 12	1.75	95	29.86	45	9.9	10.25	12.3	32.7	34.5	14	.0112
M 14	2	110	36.12	48	11.6	12	14.3	39.3	41.5	16	.0114
M 16	2	110	40.13	48	13.6	14	16.3	43.3	45.9	18	.0116

BGF-VHM-Z2
2.5xD
R30-IKZ-HB

BGF-VHM-Z2
2.5xD
R30-IKZ-HB
TICN

M 6	•	•
M 8	•	•
M 10	•	•
M 12	•	•
M 14	•	•
M 16	•	•

Other sizes upon request

- Product Finder
- v_c / f_z
- UNC
- UNF
- UN
- M
- MF**
- NPSF
- Rp (BSPP)
- G
- W
- BSW, BSF
- NPT
- NPTF
- Rc (BSPT)
- STI
- SELF-LOCK
- Accessories
- Tech. Info

Metric Shank

Carbide

R30

RH + LH

2 Flutes

DIN 6535



TICN

Coating

Applications – Material

K 1.1-3.2	N 1.1-5	K 1.1-3.2	N 1.1-6
N 2.2-3, 2.6	N 3.1-2, 4.1	N 2.2-3, 2.6	N 3.1-2, 4.1

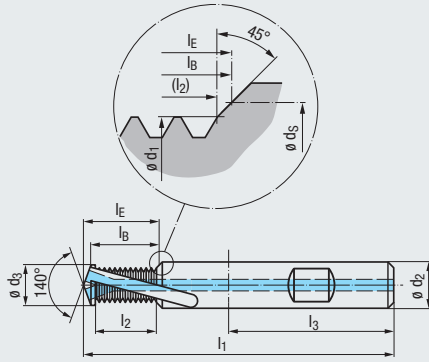

ISO Metric Fine Thread DIN 13

Thread Depth

1.5 x D

Tool Identification

GF422201

GF422206

Nominal Size	$\varnothing D$	P mm	l_1	l_2	l_3	mm			l_B	l_E	$\varnothing d_2$	Dimens. ID	BGF-VHM-Z2 1.5xD R30-1KZ-HB	BGF-VHM-Z2 1.5xD R30-1KZ-HB TICN
						$\varnothing d_1$	$\varnothing d_3$	$\varnothing d_5$						
M 4 x 0.5	49	5.05	36	3.36	3.5	4.3	7	7.6	6	.0210				
M 5 x 0.5	55	7.56	36	4.34	4.5	5.3	8.5	9.3	6	.0218				
M 6 x 0.75	62	9.07	36	5.05	5.25	6.3	10.4	11.3	8	.0229	●	●		
M 8 x 1	74	12.09	40	6.75	7	8.3	13.8	15	10	.0251	●	●		
M 10 x 1	79	15.11	45	8.7	9	10.3	16.8	18.4	12	.0276	●	●		
M 10 x 1.25	79	15.11	45	8.4	8.75	10.3	17.2	18.8	12	.0277	●	●		
M 12 x 1	89	17.14	45	10.65	11	12.3	18.8	20.8	14	.0301				
M 12 x 1.25	89	18.88	45	10.4	10.75	12.3	20.9	22.9	14	.0302	●	●		
M 12 x 1.5	89	18.12	45	10.15	10.5	12.3	20.5	22.5	14	.0303	●	●		
M 14 x 1.5	102	21.14	48	12.1	12.5	14.3	23.6	25.8	16	.0331	●	●		
M 16 x 1.5	102	24.15	48	14.1	14.5	16.3	26.6	29.2	18	.0359	●	●		

Thread Depth

2 x D

Tool Identification

GF432201

GF432206

Nominal Size	$\varnothing D$	P mm	l_1	l_2	l_3	mm			l_B	l_E	$\varnothing d_2$	Dimens. ID	BGF-VHM-Z2 2xD R30-1KZ-HB	BGF-VHM-Z2 2xD R30-1KZ-HB TICN
						$\varnothing d_1$	$\varnothing d_3$	$\varnothing d_5$						
M 4 x 0.5	49	8.05	36	3.36	3.5	4.3	9	9.6	6	.0210				
M 5 x 0.5	55	10.06	36	4.34	4.5	5.3	11	11.8	6	.0218				
M 6 x 0.75	62	12.07	36	5.05	5.25	6.3	13.4	14.3	8	.0229	●	●		
M 8 x 1	74	16.09	40	6.75	7	8.3	17.8	19	10	.0251	●	●		
M 10 x 1	79	20.11	45	8.7	9	10.3	21.8	23.4	12	.0276	●	●		
M 10 x 1.25	79	20.11	45	8.4	8.75	10.3	22.2	23.8	12	.0277	●	●		
M 12 x 1	89	24.14	45	10.65	11	12.3	25.8	27.8	14	.0301				
M 12 x 1.25	89	23.88	45	10.4	10.75	12.3	25.9	27.9	14	.0302	●	●		
M 12 x 1.5	89	24.12	45	10.15	10.5	12.3	26.5	28.5	14	.0303	●	●		
M 14 x 1.5	102	27.14	48	12.1	12.5	14.3	29.6	31.8	16	.0331	●	●		
M 16 x 1.5	102	31.65	48	14.1	14.5	16.3	34.1	36.7	18	.0359	●	●		

Other sizes upon request

Metric Shank

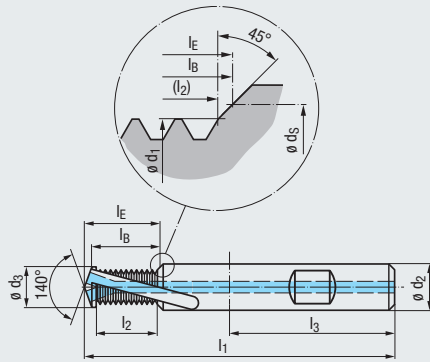

Carbide

R30 RH + LH

2 Flutes



DIN 6535



90°



ø D

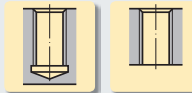

STI-M
ISO Metric Coarse Thread DIN 8140-2
For wire thread inserts

Coating

TICN

Applications – Material

K 1.1-3.2	N 1.1-5	K 1.1-3.2	N 1.1-6
N 2.2-3, 2.6	N 3.1-2, 4.1	N 2.2-3, 2.6	N 3.1-2, 4.1

Thread Depth

1.5 x D

Tool Identification													GF422201	GF422206
Nominal Size												Dimens. ID	BGF-VHM-Z2	BGF-VHM-Z2
ø D	P mm	l ₁	l ₂	l ₃	ø d ₁	mm ø d ₃	ø d _S	l _B	l _E	ø d ₂	1.5xD		1.5xD	
STI-M 6	1	74	10.10	40	6	6.3	7.6	11.8	12.9	10	.0971	●	●	
STI-M 8	1.25	79	12.60	45	8.1	8.4	9.9	14.6	16.1	12	.0973	●	●	
STI-M 10	1.5	89	16.63	45	10	10.4	12.25	19.1	21	14	.0975	●	●	
STI-M 12	1.75	102	19.38	48	12.1	12.5	14.6	22.2	24.5	16	.0977	●	●	
STI-M 14	2	102	22.12	48	14.1	14.5	16.9	25.3	28	18	.0978	●	●	
STI-M 16	2	115	26.17	50	16	16.5	18.9	29.4	32.4	20	.0979	●	●	

Thread Depth

2 x D

Tool Identification													GF432201	GF432206
Nominal Size												Dimens. ID	BGF-VHM-Z2	BGF-VHM-Z2
ø D	P mm	l ₁	l ₂	l ₃	ø d ₁	mm ø d ₃	ø d _S	l _B	l _E	ø d ₂	2xD		2xD	
STI-M 6	1	74	13.10	40	6	6.3	7.6	14.8	15.9	10	.0971	●	●	
STI-M 8	1.25	79	16.35	45	8.1	8.4	9.9	18.4	19.9	12	.0973	●	●	
STI-M 10	1.5	89	21.13	45	10	10.4	12.25	23.6	25.5	14	.0975	●	●	
STI-M 12	1.75	102	24.63	48	12.1	12.5	14.6	27.5	29.7	16	.0977	●	●	
STI-M 14	2	102	30.12	48	14.1	14.5	16.9	33.3	36	18	.0978	●	●	
STI-M 16	2	115	34.17	50	16	16.5	18.9	37.4	40.4	20	.0979	●	●	

Other sizes upon request

- Product Finder
- v_c / f_z
- UNC
- UNF
- UN
- M
- MF
- NPSF
- Rp (BSPP)
- G
- W
- BSW, BSF
- NPT
- NPTF
- Rc (BSPT)
- STI
- SELF-LOCK
- Accessories
- Tech. Info

- BGF
- ZBGF
- GSF (Aero)
- GSF-Z
- GF(I), GF-Z
- GF-Vario-Z
- GF-H
- GF(I)-KEG
- ZGF(I)
- CIRC-GF
- Gigant
- FPC, FMC
- MoSys



● = In stock
★ = Allow 7 days for delivery

- Product Finder
- v_c / f_z
- UNC
- UNF
- UN
- M
- MF
- NPSF
- Rp (BSPP)
- G
- W
- BSW, BSF
- NPT
- NPTF
- Rc (BSPT)
- STI
- SELF-LOCK
- Accessories
- Tech. Info

- BGF**
- ZBGF
- GSF (Aero)
- GSF-Z
- GF(I), GF-Z
- GF-Vario-Z
- GF-H
- GF(I)-KEG
- ZGF(I)
- CIRC-GF
- Gigant
- FPC, FMC
- MoSys

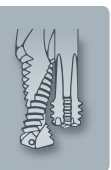

For Soft/Unhardened Materials

ZBGF-W

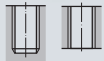

Metric Shank

For Hard Materials

ZBGF-H

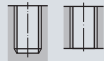

Metric Shank

For the Machining of Aluminum and Cast Iron

ZBGF-T

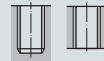

Metric Shank

Page

244

245

UNC

246

247

UNF

248

249

250

M, MF

Product Finder

v_c / f_z

UNC

UNF

UN

M

MF

NPSF

Rp (BSPP)

G

W

BSW, BSF

NPT

NPTF

Rc (BSPT)

STI

SELF-LOCK

Accessories

Tech. Info

BGF

ZBGF

GSF (Aero)

GSF-Z

GF(I), GF-Z

GF-Vario-Z

GF-H

GF(I)-KEG

ZGF(I)

CIRC-GF

Gigant

FPC, FMC

MoSys



Thread milling cycle

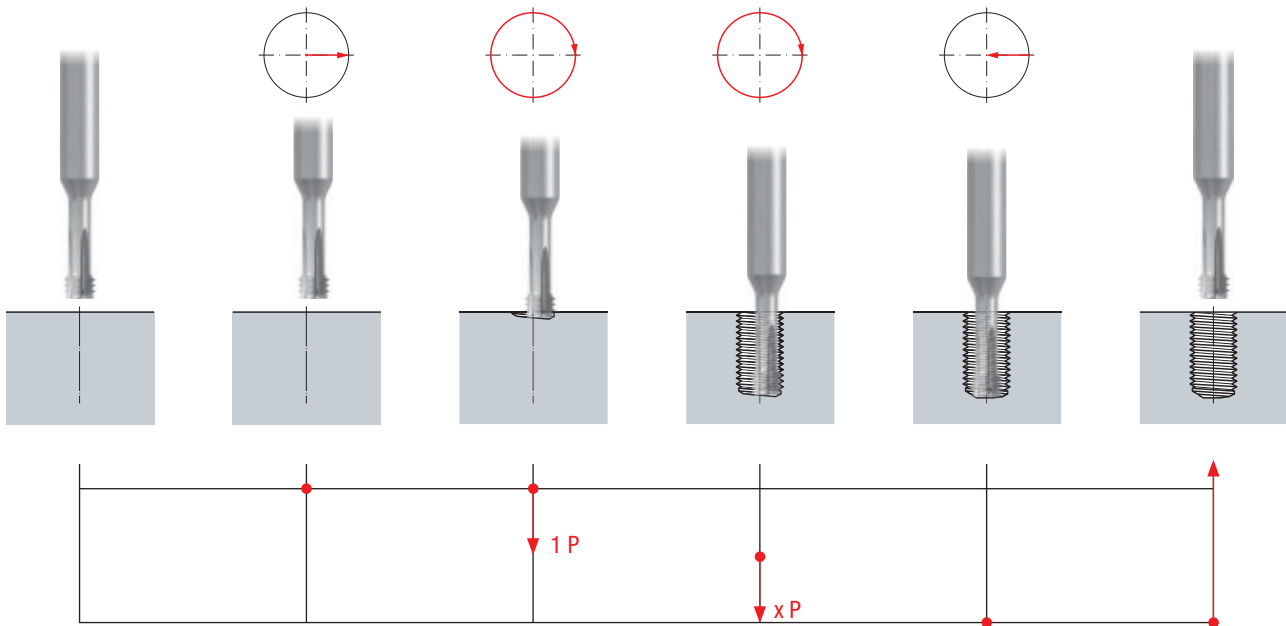

Need programming assistance?

EMUGE's trained thread milling specialist can assist you with advice and guidance in writing the correct program for your CNC machine tool. Thread milling experts will analyze your exact application and help guide you through the proper line code programming.

Contact EMUGE Technical Support department or visit www.emuge.com

- Product Finder
- v_c / f_z
- UNC
- UNF
- UN
- M
- MF
- NPSF
- Rp (BSPP)
- G
- W
- BSW, BSF
- NPT
- NPTF
- Rc (BSPT)
- STI
- SELF-LOCK
- Accessories
- Tech. Info
- BGF
- ZBGF
- GSF (Aero)
- GSF-Z
- GF(I), GF-Z
- GF-Vario-Z
- GF-H
- GF(I)-KEG
- ZGF(I)
- CIRC-GF
- Gigant
- FPC, FMC
- MoSys

Metric Shank

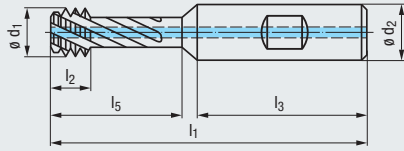

Carbide

RH + LH

RH-rot.

R30

3-5 Flutes



DIN 6535



$\varnothing D$



ZBGF-W

For soft/unhardened materials



Coating

TIALN-T4

Applications – Material

P	1.1-5.1	M	1.1-4.1	K	1.1-4.2
N	1.1-6, 2.1-6	N	3.1-2	N	4.1, 4.3-4
S	1.1-3	S	2.1-2, 2.4	H	1.1-2

UNC



Unified Coarse Thread
ASME B1.1

Thread Depth

2 x D

Tool Identification

GF732257

Nominal Size	T.P.I.	l_1	l_2	inch		l_5	$\varnothing d_1$		Flutes	Dimens. ID
				l_3	l_4		inch	mm		
1/4	20	2.362	0.228	1.417	0.669	0.183	0.315	8	3	.5009
5/16	18	2.992	0.252	1.575	0.866	0.222	0.394	10	4	.5010
3/8	16	2.992	0.283	1.575	1.024	0.282	0.394	10	4	.5011
7/16	14	3.386	0.319	1.772	1.220	0.333	0.472	12	4	.5012
1/2	13	3.386	0.350	1.772	1.299	0.397	0.472	12	4	.5013
5/8	11	3.858	0.409	1.890	1.654	0.507	0.630	16	4	.5015
3/4	10	4.370	0.449	1.969	2.008	0.610	0.787	20	5	.5016

ZBGF-W-VHM
2xD
R30-IKZ-HB
TIALN-T4

Other sizes upon request

Metric Shank

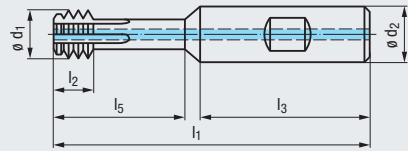

Carbide

RH

LH-rot.

4-5 Flutes



DIN 6535



ø D



ZBGF-H
For hard materials



UNC

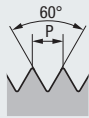

**Unified Coarse Thread
ASME B1.1**

Tool Identification

Nominal Size ø D	T.P.I.	l ₁	l ₂	inch		l ₅	ø d ₁	ø d ₂		Flutes	Dimens. ID
				l ₃	l ₅			inch	mm		
5/16	18	2.992	0.220	1.575	0.866	0.222	0.394	10	4	.5010	
3/8	16	2.992	0.252	1.575	1.063	0.282	0.394	10	4	.5011	
7/16	14	3.386	0.287	1.772	1.220	0.333	0.472	12	4	.5012	
1/2	13	3.386	0.307	1.772	1.299	0.397	0.472	12	4	.5013	
5/8	11	3.858	0.362	1.890	1.654	0.507	0.630	16	4	.5015	
3/4	10	4.370	0.402	1.969	2.008	0.610	0.787	20	5	.5016	

Other sizes upon request

Coating

TIALN-T3

Applications – Material

N 2.7-8 H 1.1-5

Thread Depth

2 x D

GF733208

ZBGF-H-VHM
2xD
IKZ-HB
TIALN-T3

Product Finder

v_c / f_z

UNC

UNF

UN

M

MF

NPSF

Rp (BSPP)

G

W

BSW, BSF

NPT

NPTF

Rc (BSPT)

STI

SELF-LOCK

Accessories

Tech. Info

BGF

ZBGF

GSF (Aero)

GSF-Z

GF(I), GF-Z

GF-Vario-Z

GF-H

GF(I)-KEG

ZGF(I)

CIRC-GF

Gigant

FPC, FMC

MoSys



- Product Finder
- v_c / f_z
- UNC
- UNF**
- UN
- M
- MF
- NPSF
- Rp (BSPP)
- G
- W
- BSW, BSF
- NPT
- NPTF
- Rc (BSPT)
- STI
- SELF-LOCK
- Accessories
- Tech. Info
- BGF
- ZBGF**
- GSF (Aero)
- GSF-Z
- GF(I), GF-Z
- GF-Vario-Z
- GF-H
- GF(I)-KEG
- ZGF(I)
- CIRC-GF
- Gigant
- FPC, FMC
- MoSys

Metric Shank

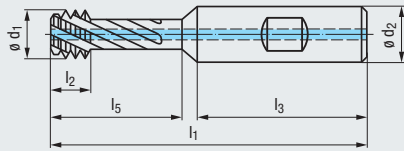

Carbide

RH + LH

RH-rot.

R30

3-5 Flutes



DIN 6535



$\varnothing D$



ZBGF-W
For soft/unhardened materials



UNF



Unified Fine Thread
ASME B1.1

Coating

TIALN-T4

Applications – Material

P 1.1-5.1	M 1.1-4.1	K 1.1-4.2
N 1.1-6, 2.1-6	N 3.1-2	N 4.1, 4.3-4
S 1.1-3	S 2.1-2, 2.4	H 1.1-2

Thread Depth

2 x D

Tool Identification

GF732257

Nominal Size	T.P.I.	l_1	l_2	inch		l_5	$\varnothing d_1$	$\varnothing d_2$		Flutes	Dimens. ID	ZBGF-W-VHM 2xD R30-IKZ-HB TIALN-T4
				l_3				inch	mm			
1/4	28	2.362	0.165	1.417	0.669	0.183	0.315	8	3	.5043	●	
5/16	24	2.992	0.189	1.575	0.866	0.222	0.394	10	4	.5044	●	
3/8	24	2.992	0.189	1.575	1.024	0.281	0.394	10	4	.5045	●	
7/16 - 1/2	20	3.386	0.228	1.772	1.299	0.333	0.472	12	4	.5046	●	
9/16 - 5/8	18	3.858	0.252	1.890	1.614	0.444	0.630	16	4	.5048	●	
3/4	16	4.370	0.283	1.969	2.008	0.606	0.787	20	5	.5050	●	

Other sizes upon request

Metric Shank

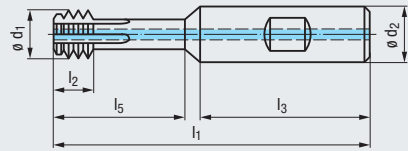

Carbide

RH

LH-rot.

4-5 Flutes



DIN 6535



ø D



ZBGF-H
For hard materials



UNF

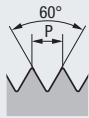

Unified Fine Thread
ASME B1.1

Tool Identification

Nominal Size	T.P.I.	l ₁	l ₂	inch		l ₅	ø d ₁		Flutes	Dimens. ID
				l ₃	l ₅		inch	mm		
5/16	24	2.992	0.165	1.575	0.866	0.222	0.394	10	4	.5044
3/8	24	2.992	0.165	1.575	1.063	0.281	0.394	10	4	.5045
7/16 - 1/2	20	3.386	0.201	1.772	1.299	0.333	0.472	12	4	.5046
9/16 - 5/8	18	3.858	0.220	1.890	1.614	0.444	0.630	16	4	.5048
3/4	16	4.370	0.252	1.969	2.008	0.606	0.787	20	5	.5050

Other sizes upon request

Coating

TIALN-T3

Applications – Material

N 2.7-8 H 1.1-5

Thread Depth

2 x D

GF733208

ZBGF-H-VHM
2xD
IKZ-HB
TIALN-T3

Product Finder

v_c / f_z

UNC

UNF

UN

M

MF

NPSF

Rp (BSPP)

G

W

BSW, BSF

NPT

NPTF

Rc (BSPT)

STI

SELF-LOCK

Accessories

Tech. Info

BGF

ZBGF

GSF (Aero)

GSF-Z

GF(I), GF-Z

GF-Vario-Z

GF-H

GF(I)-KEG

ZGF(I)

CIRC-GF

Gigant

FPC, FMC

MoSys



- Product Finder
- v_c / f_z
- UNC
- UNF
- UN
- M**
- MF**
- NPSF
- Rp (BSPP)
- G
- W
- BSW, BSF
- NPT
- NPTF
- Rc (BSPT)
- STI
- SELF-LOCK
- Accessories
- Tech. Info
- BGF
- ZBGF
- GSF (Aero)
- GSF-Z
- GF(I), GF-Z
- GF-Vario-Z
- GF-H
- GF(I)-KEG
- ZGF(I)
- CIRC-GF
- Gigant
- FPC, FMC
- MoSys

Metric Shank

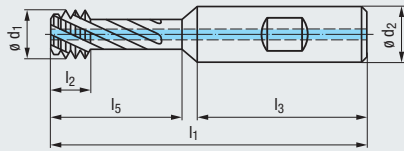

Carbide

RH + LH

RH-rot.

R30

3-4 Flutes



DIN 6535



$\varnothing D$



ZBGF-W For soft/unhardened materials



M, MF

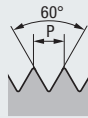

ISO Metric Threads DIN 13

Coating

TIALN-T4

Applications – Material

P 1.1-5.1	M 1.1-4.1	K 1.1-4.2
N 1.1-6, 2.1-6	N 3.1-2	N 4.1, 4.3-4
S 1.1-3	S 2.1-2, 2.4	H 1.1-2

Thread Depth

2 x D

Tool Identification

GF732257

ZBGF-W-VHM
2xD
R30-IKZ-HB
TIALN-T4

P mm	$\varnothing D$	l_1	l_2	mm			$\varnothing d_1$	$\varnothing d_2$	Flutes	Dimens. ID
				l_3	l_5					
1	M 6 - M 7	60	4.6	36	16	4.51	8	3	.0060	
1.25	M 8 - M10 x 1.25	71	5.7	40	21	6.23	10	4	.0080	
1.5	M10 - M12 x 1.5	76	6.9	40	26	7.75	10	4	.0100	
1.75	M12	86	7.9	45	32	9.16	12	4	.0112	
2	M14 - M16	98	9.1	48	41	11.08	16	4	.0114	

Other sizes upon request

Metric Shank

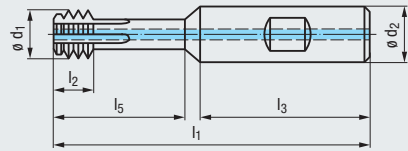

Carbide

RH

LH-rot.

4 Flutes



DIN 6535



ø D



ZBGF-H
For hard materials



M, MF

ISO Metric Threads
DIN 13

Coating

TIALN-T3

Applications – Material

N 2.7-8 H 1.1-5

Thread Depth

2 x D

Tool Identification

GF733208

P mm	ø D	l ₁	l ₂	mm		ø d ₁	ø d ₂	Flutes	Dimens. ID
				l ₃	l ₅				
1.25	M 8 - M10 x 1.25	71	5	40	19	6.2	10	4	.0080
1.5	M10 - M12 x 1.5	76	6	40	25	7.75	10	4	.0100
1.75	M12	86	7	45	31	9.2	12	4	.0112
2	M14 - M16	98	8	48	36	11.1	16	4	.0114

ZBGF-H-VHM
2xD
IKZ-HB
TIALN-T3

Other sizes upon request

Product Finder

v_c / f_z

UNC

UNF

UN

M

MF

NPSF

Rp (BSPP)

G

W

BSW, BSF

NPT

NPTF

Rc (BSPT)

STI

SELF-LOCK

Accessories

Tech. Info

BGF

ZBGF

GSF (Aero)

GSF-Z

GF(I), GF-Z

GF-Vario-Z

GF-H

GF(I)-KEG

ZGF(I)

CIRC-GF

Gigant

FPC, FMC

MoSys



- Product Finder
- v_c / f_z
- UNC
- UNF
- UN
- M**
- MF**
- NPSF
- Rp (BSPP)
- G
- W
- BSW, BSF
- NPT
- NPTF
- Rc (BSPT)
- STI
- SELF-LOCK
- Accessories
- Tech. Info
- BGF
- ZBGF**
- GSF (Aero)
- GSF-Z
- GF(I), GF-Z
- GF-Vario-Z
- GF-H
- GF(I)-KEG
- ZGF(I)
- CIRC-GF
- Gigant
- FPC, FMC
- MoSys

Metric Shank

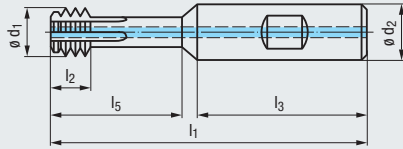

Carbide

RH + LH

RH-rot.

3-4 Flutes



DIN 6535



ZBGF-T

For the machining of aluminum and cast iron



TICN

K 1.1-2 **N** 1.1-6, 3.1-2

M, MF

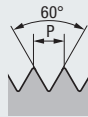

ISO Metric Threads
DIN 13

Coating

Applications – Material

Thread Depth

3 x D

Tool Identification

GF753276

ZBGF-T-VHM
3xD
IKZ-HB
TICN

P mm	ø D	l ₁	l ₂	mm			ø d ₁	ø d ₂	Flutes	Dimens. ID
				l ₃	l ₅					
1	M 6 - M 7	65	4	36	20	4.5	8	3	.0060	
1.25	M 8 - M10 x 1.25	80	5	40	27	6.2	10	4	.0080	
1.5	M10 - M12 x 1.5	85	6	40	34	7.75	10	4	.0100	
1.75	M12	100	7	45	39	9.2	12	4	.0112	

Other sizes upon request

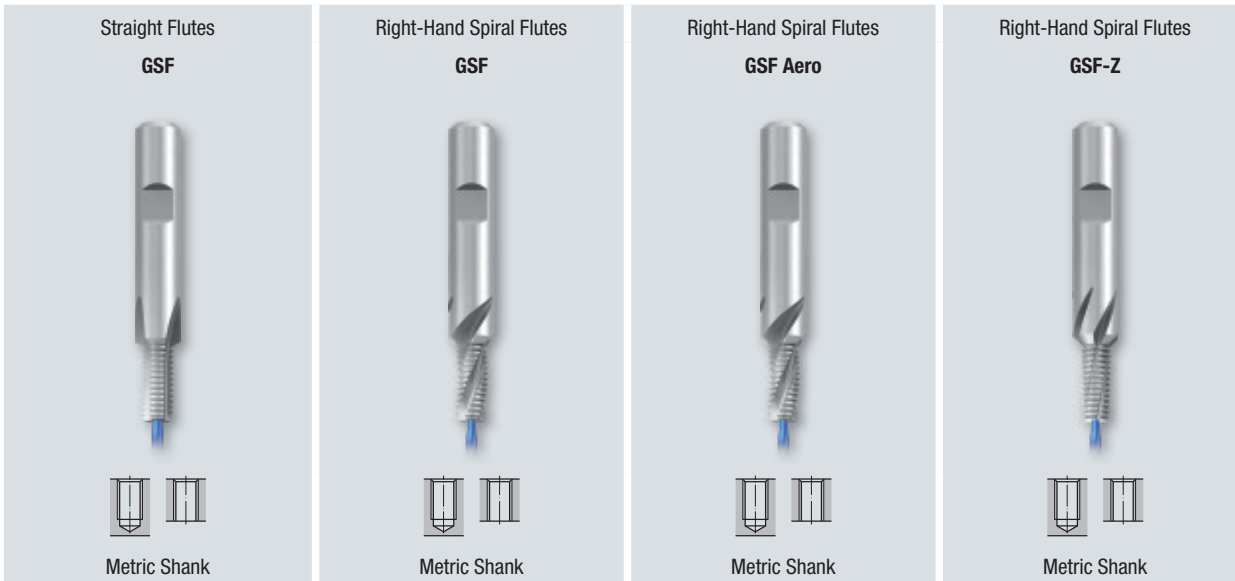

Page

	252	253		UNC
	254	255		UNF
	256		257	M
	258		259	MF
	260			G (BSP)
261				LK-M

Product Finder

- v_c / f_z
- UNC
- UNF
- UN
- M
- MF
- NPSF
- Rp (BSPF)
- G
- W
- BSW, BSF
- NPT
- NPTF
- Rc (BSPT)
- STI
- SELF-LOCK
- Accessories
- Tech. Info
- BGF
- ZBGF
- GSF (Aero)
- GSF-Z
- GF(I), GF-Z
- GF-Vario-Z
- GF-H
- GF(I)-KEG
- ZGF(I)
- CIRC-GF
- Gigant
- FPC, FMC
- MoSys

Possible modifications

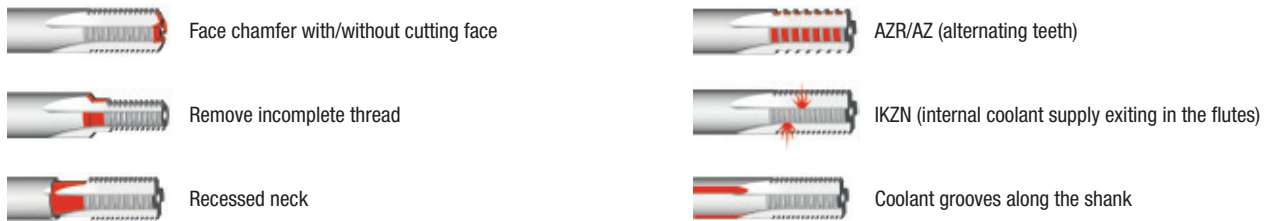

For a description of these modifications, see page 357

Thread milling cycle

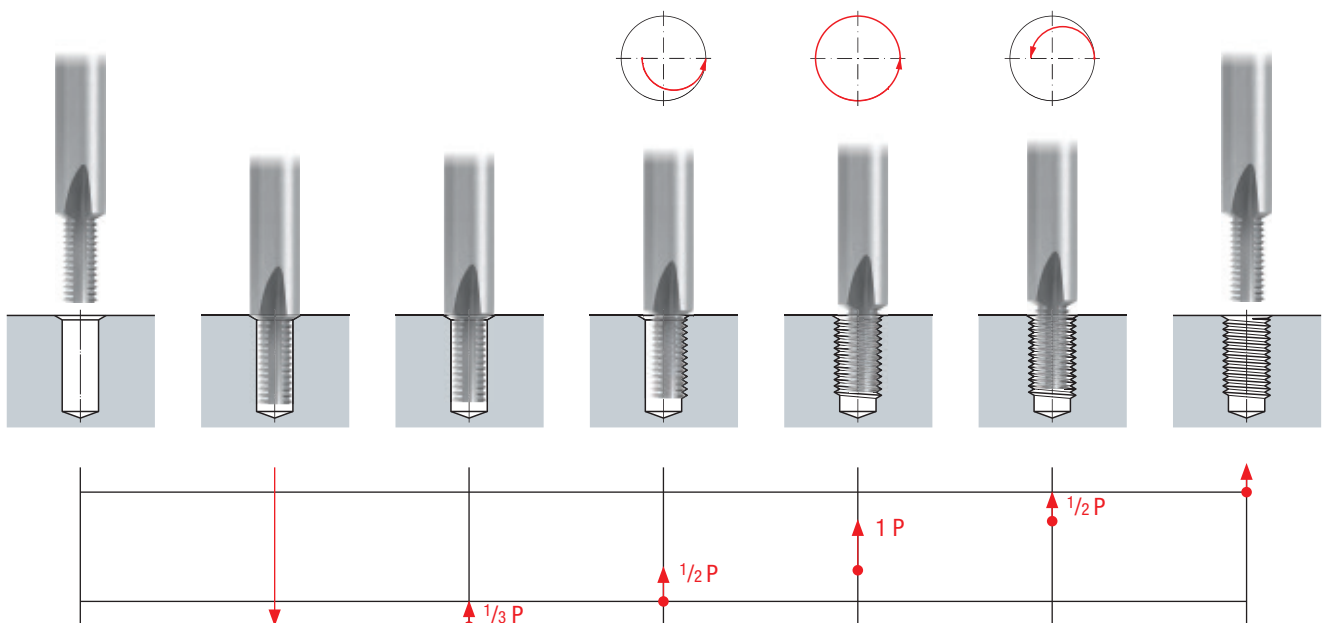

- Product Finder
- v_c / f_z
- UNC
- UNF
- UN
- M
- MF
- NPSF
- Rp (BSPP)
- G
- W
- BSW, BSF
- NPT
- NPTF
- Rc (BSPT)
- STI
- SELF-LOCK
- Accessories
- Tech. Info

Metric Shank

Carbide

R30 RH + LH

3-5 Flutes DIN 6535

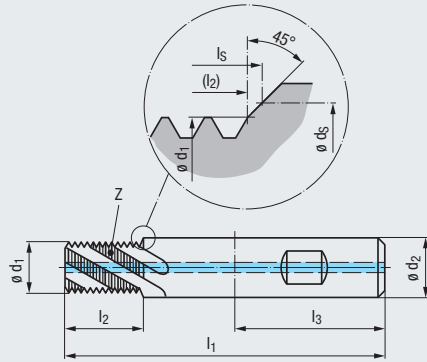
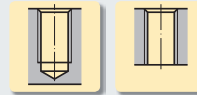
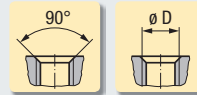

Coating

TICN

Applications – Material

P	1.1-3.1	K	1.1-4.2	P	1.1-3.1	M	1.1-2.1
N	1.1-5	N	2.1-6	K	1.1-4.2	N	1.1-2.7
N	3.1-4.2, 5.2	S	1.1-2	N	3.1-5.2	S	1.1-2, 2.1

UNC



Unified Coarse Thread
ASME B1.1

Thread Depth

1.5 x D

Tool Identification

GF322101

GF322106

Nominal Size	T.P.I.	l_1	l_2	l_3	inch			ϕd_2		Flutes	Dimens. ID
					ϕd_1	ϕd_s	l_s	inch	mm		
No. 12	24	2.441	0.354	1.417	0.163	0.228	0.382	0.315	8	3	.5008
1/4	20	2.441	0.425	1.417	0.185	0.262	0.461	0.315	8	3	.5009
5/16	18	2.913	0.528	1.575	0.242	0.325	0.567	0.394	10	3	.5010
3/8	16	3.150	0.594	1.772	0.301	0.387	0.634	0.472	12	3	.5011
7/16	14	3.150	0.681	1.772	0.354	0.450	0.720	0.472	12	3	.5012
1/2	13	3.543	0.811	1.772	0.407	0.512	0.854	0.551	14	4	.5013
9/16	12	3.937	0.878	1.890	0.465	0.575	0.925	0.630	16	4	.5014
5/8	11	4.016	0.957	1.890	0.516	0.637	1.008	0.709	18	4	.5015
3/4	10	4.331	1.154	1.969	0.630	0.762	1.209	0.787	20	5	.5016

GSF-VHM
1.5xD
R30-1KZ-HB

GSF-VHM
1.5xD
R30-1KZ-HB
TICN

•	•
•	•
•	•
•	•
•	•
•	•
•	•
•	•
•	•
•	•

Thread Depth

2 x D

Tool Identification

GF332101

GF332106

Nominal Size	T.P.I.	l_1	l_2	l_3	inch			ϕd_2		Flutes	Dimens. ID
					ϕd_1	ϕd_s	l_s	inch	mm		
No. 12	24	2.441	0.437	1.417	0.163	0.228	0.469	0.315	8	3	.5008
1/4	20	2.441	0.524	1.417	0.185	0.262	0.559	0.315	8	3	.5009
5/16	18	2.913	0.638	1.575	0.242	0.325	0.677	0.394	10	3	.5010
3/8	16	3.150	0.783	1.772	0.301	0.387	0.819	0.472	12	3	.5011
7/16	14	3.150	0.894	1.772	0.354	0.450	0.937	0.472	12	3	.5012
1/2	13	3.543	1.039	1.772	0.407	0.512	1.087	0.551	14	4	.5013
9/16	12	3.937	1.209	1.890	0.465	0.575	1.260	0.630	16	4	.5014
5/8	11	4.016	1.319	1.890	0.516	0.637	1.374	0.709	18	4	.5015
3/4	10	4.331	1.551	1.969	0.630	0.762	1.610	0.787	20	5	.5016

GSF-VHM
2xD
R30-1KZ-HB

GSF-VHM
2xD
R30-1KZ-HB
TICN

•	•
•	•
•	•
•	•
•	•
•	•
•	•
•	•
•	•
•	•

Thread Depth

2.5 x D

Tool Identification

GF342101

GF342106

Nominal Size	T.P.I.	l_1	l_2	l_3	inch			ϕd_2		Flutes	Dimens. ID
					ϕd_1	ϕd_s	l_s	inch	mm		
3/8	16	3.346	0.969	1.772	0.301	0.387	1.008	0.472	12	3	.5011
7/16	14	3.346	1.110	1.772	0.354	0.450	1.150	0.472	12	3	.5012
1/2	13	3.780	1.272	1.772	0.407	0.512	1.315	0.551	14	4	.5013
9/16	12	4.213	1.461	1.890	0.465	0.575	1.508	0.630	16	4	.5014
5/8	11	4.331	1.594	1.890	0.516	0.637	1.646	0.709	18	4	.5015
3/4	10	4.921	1.953	1.969	0.630	0.762	2.012	0.787	20	5	.5016

GSF-VHM
2.5xD
R30-1KZ-HB

GSF-VHM
2.5xD
R30-1KZ-HB
TICN

•	•
•	•
•	•
•	•
•	•
•	•

Metric Shank

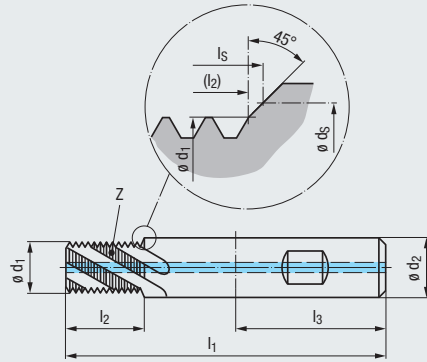

Carbide

R15 RH + LH

3-5 Flutes **DIN 6535**
 HB
 HE HA

90°



Coating

TICN

Applications – Material

P	1.1-5.1	K	1.1-4.2	P	1.1-5.1	M	1.1-4.1
N	1.1-5	N	2.1-6	K	1.1-4.2	N	1.1-5.2
N	3.1-4.2, 5.2	S	1.1-3	S	1.1-2.6	H	1.1-2

UNC

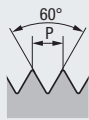

**Unified Coarse Thread
ASME B1.1**

Thread Depth

2 x D

Tool Identification

											GF335101		GF335106		
											GSF-VHM 2xD R15-IKZ-HB		GSF-VHM 2xD R15-IKZ-HB TICN		
Nominal Size	T.P.I.	l_1	l_2	l_3	inch			ϕd_2		Flutes	Dimens. ID				
ϕD					ϕd_1	ϕd_s	l_s	inch	mm						
No. 10	24	2.165	0.397	1.417	0.136	0.202	0.425	0.236	6	3	.5007	●	●		
No. 12	24	2.441	0.437	1.417	0.163	0.228	0.469	0.315	8	3	.5008	●	●		
1/4	20	2.441	0.524	1.417	0.185	0.262	0.559	0.315	8	3	.5009	●	●		
5/16	18	2.913	0.638	1.575	0.242	0.325	0.677	0.394	10	3	.5010	●	●		
3/8	16	3.150	0.783	1.772	0.301	0.387	0.819	0.472	12	3	.5011	●	●		
7/16	14	3.150	0.894	1.772	0.354	0.450	0.937	0.472	12	3	.5012	●	●		
1/2	13	3.543	1.039	1.772	0.407	0.512	1.087	0.551	14	4	.5013	●	●		
9/16	12	3.937	1.209	1.890	0.465	0.575	1.260	0.630	16	4	.5014	●	●		
5/8	11	4.016	1.319	1.890	0.516	0.637	1.374	0.709	18	4	.5015	●	●		
3/4	10	4.331	1.551	1.969	0.630	0.762	1.610	0.787	20	5	.5016	●	●		

Other sizes upon request

- Product Finder
- v_c / f_z
- UNC
- UNF
- UN
- M
- MF
- NPSF
- Rp (BSPP)
- G
- W
- BSW, BSF
- NPT
- NPTF
- Rc (BSPT)
- STI
- SELF-LOCK
- Accessories
- Tech. Info

- BGF
- ZBGF
- GSF Aero
- GSF-Z
- GF(I), GF-Z
- GF-Vario-Z
- GF-H
- GF(I)-KEG
- ZGF(I)
- CIRC-GF
- Gigant
- FPC, FMC
- MoSys



Need programming assistance?

EMUGE's trained thread milling specialist can assist you with advice and guidance in writing the correct program for your CNC machine tool. Thread milling experts will analyze your exact application and help guide you through the proper line code programming.

Contact EMUGE Technical Support department or visit www.emuge.com

● = In stock
 ★ = Allow 7 days for delivery

- Product Finder
- v_c / f_z
- UNC
- UNF
- UN
- M
- MF
- NPSF
- Rp (BSPP)
- G
- W
- BSW, BSF
- NPT
- NPTF
- Rc (BSPT)
- STI
- SELF-LOCK
- Accessories
- Tech. Info

Metric Shank

Carbide

R30

RH + LH

3-5 Flutes



DIN 6535



90°



ϕD

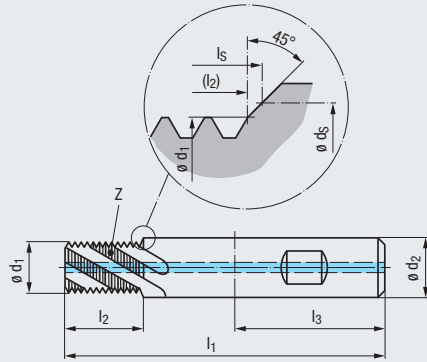

Coating

TICN

Applications – Material

P	1.1-3.1	K	1.1-4.2	P	1.1-3.1	M	1.1-2.1
N	1.1-5	N	2.1-6	K	1.1-4.2	N	1.1-2.7
N	3.1-4.2, 5.2	S	1.1-2	N	3.1-5.2	S	1.1-2, 2.1

UNF

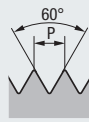

Unified Fine Thread
ASME B1.1

Thread Depth

1.5 x D

Tool Identification

GF322101

GF322106

Nominal Size	ϕD	T.P.I.	l_1	l_2	inch			l_S	ϕd_2		Flutes	Dimens. ID	GSF-VHM 1.5xD R30-1KZ-HB	GSF-VHM 1.5xD R30-1KZ-HB TICN
					ϕd_1	ϕd_S	l_3		inch	mm				
No. 10	32	2.165	0.299	1.417	0.150	0.202	0.319	0.236	6	3	.5041	●	●	
No. 12	28	2.441	0.339	1.417	0.169	0.228	0.366	0.315	8	3	.5042	●	●	
1/4	28	2.441	0.413	1.417	0.203	0.262	0.437	0.315	8	3	.5043	●	●	
5/16	24	2.913	0.480	1.575	0.260	0.325	0.508	0.394	10	3	.5044	●	●	
3/8	24	3.150	0.563	1.772	0.323	0.387	0.591	0.472	12	3	.5045	●	●	
7/16	20	3.150	0.677	1.772	0.376	0.450	0.709	0.472	12	3	.5046	●	●	
1/2	20	3.543	0.776	1.772	0.437	0.512	0.807	0.551	14	4	.5047	●	●	
9/16	18	3.937	0.862	1.890	0.492	0.575	0.898	0.630	16	4	.5048	●	●	
5/8	18	4.016	0.976	1.890	0.555	0.637	1.008	0.709	18	4	.5049	●	●	
3/4	16	4.331	1.161	1.969	0.669	0.762	1.197	0.787	20	5	.5050	●	●	

Thread Depth

2 x D

Tool Identification

GF332101

GF332106

Nominal Size	ϕD	T.P.I.	l_1	l_2	inch			l_S	ϕd_2		Flutes	Dimens. ID	GSF-VHM 2xD R30-1KZ-HB	GSF-VHM 2xD R30-1KZ-HB TICN
					ϕd_1	ϕd_S	l_3		inch	mm				
No. 10	32	2.165	0.390	1.417	0.150	0.202	0.413	0.236	6	3	.5041	●	●	
No. 12	28	2.441	0.449	1.417	0.169	0.228	0.472	0.315	8	3	.5042	●	●	
1/4	28	2.441	0.520	1.417	0.203	0.262	0.543	0.315	8	3	.5043	●	●	
5/16	24	2.913	0.646	1.575	0.260	0.325	0.673	0.394	10	3	.5044	●	●	
3/8	24	3.150	0.772	1.772	0.323	0.387	0.799	0.472	12	3	.5045	●	●	
7/16	20	3.150	0.878	1.772	0.376	0.450	0.909	0.472	12	3	.5046	●	●	
1/2	20	3.543	1.028	1.772	0.437	0.512	1.059	0.551	14	4	.5047	●	●	
9/16	18	3.937	1.142	1.890	0.492	0.575	1.177	0.630	16	4	.5048	●	●	
5/8	18	4.016	1.307	1.890	0.555	0.637	1.343	0.709	18	4	.5049	●	●	
3/4	16	4.331	1.535	1.969	0.669	0.762	1.575	0.787	20	5	.5050	●	●	

Other sizes upon request

Metric Shank

Carbide

R15 RH + LH

3-5 Flutes **DIN 6535**

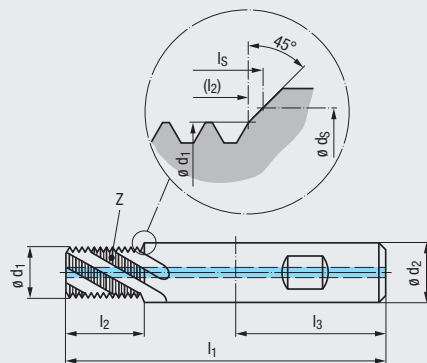
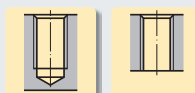
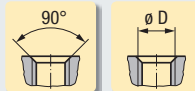

Unified Fine Thread ASME B1.1

Coating

TICN

Applications – Material

P	1.1-5.1	K	1.1-4.2	P	1.1-5.1	M	1.1-4.1
N	1.1-5	N	2.1-6	K	1.1-4.2	N	1.1-5.2
N	3.1-4.2, 5.2	S	1.1-3	S	1.1-2.6	H	1.1-2

Thread Depth

2 x D

Tool Identification

Nominal Size											Dimens. ID	GF335101	GF335106
Ø D	T.P.I.	l ₁	l ₂	l ₃	inch			Ø d ₂		Flutes		GSF-VHM 2xD R15-IKZ-HB	GSF-VHM 2xD R15-IKZ-HB TICN
No. 10	32	2.165	0.390	1.417	0.150	0.202	0.413	0.236	6	3	.5041	●	●
No. 12	28	2.441	0.449	1.417	0.169	0.228	0.472	0.315	8	3	.5042	●	●
1/4	28	2.441	0.520	1.417	0.203	0.262	0.543	0.315	8	3	.5043	●	●
5/16	24	2.913	0.646	1.575	0.260	0.325	0.673	0.394	10	3	.5044	●	●
3/8	24	3.150	0.772	1.772	0.323	0.387	0.799	0.472	12	3	.5045	●	●
7/16	20	3.150	0.878	1.772	0.376	0.450	0.909	0.472	12	3	.5046	●	●
1/2	20	3.543	1.028	1.772	0.437	0.512	1.059	0.551	14	4	.5047	●	●
9/16	18	3.937	1.142	1.890	0.492	0.575	1.177	0.630	16	4	.5048	●	●
5/8	18	4.016	1.307	1.890	0.555	0.637	1.343	0.709	18	4	.5049	●	●
3/4	16	4.331	1.535	1.969	0.669	0.762	1.575	0.787	20	5	.5050	●	●

Other sizes upon request

- Product Finder
- v_c / f_z
- UNC
- UNF
- UN
- M
- MF
- NPSF
- Rp (BSPP)
- G
- W
- BSW, BSF
- NPT
- NPTF
- Rc (BSPT)
- STI
- SELF-LOCK
- Accessories
- Tech. Info
- BGF
- ZBGF
- GSF Aero
- GSF-Z
- GF(I), GF-Z
- GF-Vario-Z
- GF-H
- GF(I)-KEG
- ZGF(I)
- CIRC-GF
- Gigant
- FPC, FMC
- MoSys



Need programming assistance?

EMUGE's trained thread milling specialist can assist you with advice and guidance in writing the correct program for your CNC machine tool. Thread milling experts will analyze your exact application and help guide you through the proper line code programming.

Contact EMUGE Technical Support department or visit www.emuge.com

● = In stock
★ = Allow 7 days for delivery

- Product Finder
- v_c / f_z
- UNC
- UNF
- UN
- M**
- MF
- NPSF
- Rp (BSPP)
- G
- W
- BSW, BSF
- NPT
- NPTF
- Rc (BSPT)
- STI
- SELF-LOCK
- Accessories
- Tech. Info

Metric Shank

Carbide

R30

RH + LH

3-4 Flutes

DIN 6535



TICN

Coating
Applications – Material

P	1.1-3.1	K	1.1-4.2	P	1.1-3.1	M	1.1-2.1
N	1.1-5	N	2.1-6	K	1.1-4.2	N	1.1-2.7
N	3.1-4.2, 5.2	S	1.1-2	N	3.1-5.2	S	1.1-2, 2.1

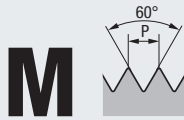
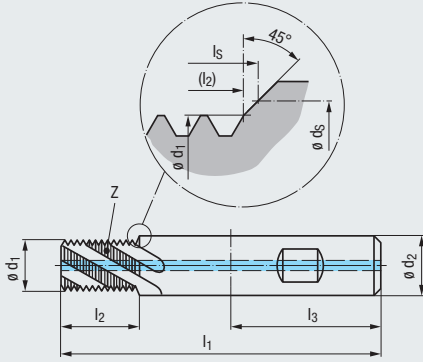

ISO Metric Coarse Thread DIN 13

Thread Depth

1.5 x D

Tool Identification

GF322101

GF322106

Nominal Size	ϕD	P mm	l_1	l_2	l_3	mm		l_5	ϕd_2	Flutes	Dimens. ID	Tool Identification	
						ϕd_1	ϕd_5					GF322101	GF322106
M 5	5	0.8	55	7.6	36	4	5.3	8.2	6	3	.0050	●	●
M 6	6	1	62	9.5	36	4.8	6.3	10.2	8	3	.0060	●	●
M 8	8	1.25	74	13.1	40	6.5	8.3	13.9	10	3	.0080	●	●
M 10	10	1.5	80	15.8	45	8.2	10.3	16.7	12	3	.0100	●	●
M 12	12	1.75	90	18.4	45	9.9	12.3	19.5	14	4	.0112	●	●
M 14	14	2	100	23	48	11.6	14.3	24.2	16	4	.0114	●	●
M 16	16	2	102	25	48	13.6	16.3	26.2	18	4	.0116	●	●

Thread Depth

2 x D

Tool Identification

GF332101

GF332106

Nominal Size	ϕD	P mm	l_1	l_2	l_3	mm		l_5	ϕd_2	Flutes	Dimens. ID	Tool Identification	
						ϕd_1	ϕd_5					GF332101	GF332106
M 5	5	0.8	55	10.8	36	4	5.3	11.4	6	3	.0050	●	●
M 6	6	1	62	12.5	36	4.8	6.3	13.2	8	3	.0060	●	●
M 8	8	1.25	74	16.9	40	6.5	8.3	17.7	10	3	.0080	●	●
M 10	10	1.5	80	20.3	45	8.2	10.3	21.2	12	3	.0100	●	●
M 12	12	1.75	90	25.4	45	9.9	12.3	26.5	14	4	.0112	●	●
M 14	14	2	100	29	48	11.6	14.3	30.2	16	4	.0114	●	●
M 16	16	2	102	33	48	13.6	16.3	34.2	18	4	.0116	●	●

Thread Depth

2.5 x D

Tool Identification

GF342101

GF342106

Nominal Size	ϕD	P mm	l_1	l_2	l_3	mm		l_5	ϕd_2	Flutes	Dimens. ID	Tool Identification	
						ϕd_1	ϕd_5					GF342101	GF342106
M 5	5	0.8	58	13.2	36	4	5.3	13.8	6	3	.0050	●	●
M 6	6	1	65	15.5	36	4.8	6.3	16.2	8	3	.0060	●	●
M 8	8	1.25	78	20.6	40	6.5	8.3	21.4	10	3	.0080	●	●
M 10	10	1.5	85	26.3	45	8.2	10.3	27.2	12	3	.0100	●	●
M 12	12	1.75	95	30.7	45	9.9	12.3	31.7	14	4	.0112	●	●
M 14	14	2	110	37	48	11.6	14.3	38.2	16	4	.0114	●	●
M 16	16	2	110	41	48	13.6	16.3	42.2	18	4	.0116	●	●

Other sizes upon request

Metric Shank

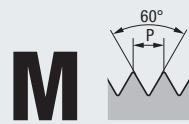
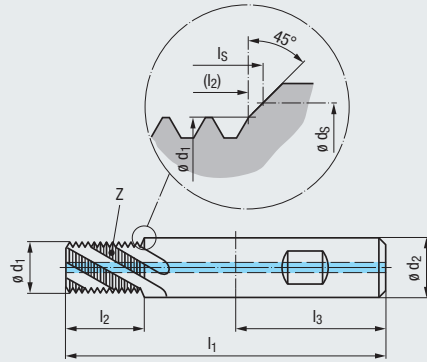

**ISO Metric Coarse Thread
DIN 13**

Tool Identification

Nominal Size	ϕD	P mm	l_1	l_2	l_3	mm				Flutes	Dimens. ID
						ϕd_1	ϕd_5	l_s	ϕd_2		
M 6	6	1	62	12.5	36	4.8	6.3	13.2	8	4	.0060
M 8	8	1.25	74	16.9	40	6.5	8.3	17.7	10	4	.0080
M 10	10	1.5	80	20.3	45	8.2	10.3	21.2	12	5	.0100
M 12	12	1.75	90	25.4	45	9.9	12.3	26.5	14	5	.0112

Other sizes upon request

Carbide

R15 RH + LH

4-5 Flutes **DIN 6535**

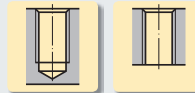
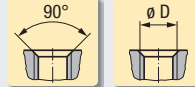

With increased number of flutes



Coating

TICN

Applications – Material

P	1.1-5.1	M	1.1-4.1
K	1.1-4.2	N	1.1-5.2
S	1.1-2.6	H	1.1-2

Thread Depth

2 x D

GF335126

GSF-Z-VHM
2xD
R15-1KZ-HB
TICN



Product Finder

v_c / f_z

UNC

UNF

UN

M

MF

NPSF

Rp (BSPP)

G

W

BSW, BSF

NPT

NPTF

Rc (BSPT)

STI

SELF-LOCK

Accessories

Tech. Info

BGF

ZBGF

GSF (Aero)

GSF-Z

GF(I), GF-Z

GF-Vario-Z

GF-H

GF(I)-KEG

ZGF(I)

CIRC-GF

Gigant

FPC, FMC

MoSys



Need programming assistance?

EMUGE's trained thread milling specialist can assist you with advice and guidance in writing the correct program for your CNC machine tool. Thread milling experts will analyze your exact application and help guide you through the proper line code programming.

Contact EMUGE Technical Support department or visit www.emuge.com

- Product Finder
- v_c / f_z
- UNC
- UNF
- UN
- M
- MF**
- NPSF
- Rp (BSPP)
- G
- W
- BSW, BSF
- NPT
- NPTF
- Rc (BSPT)
- STI
- SELF-LOCK
- Accessories
- Tech. Info

Metric Shank

Carbide

R30

RH + LH

3-4 Flutes

DIN 6535

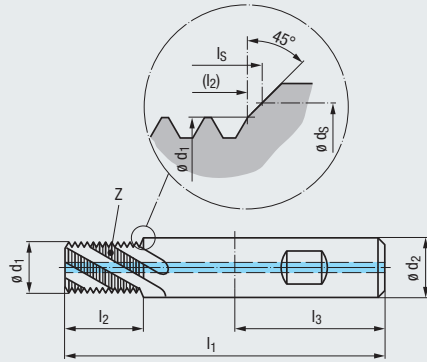

Coating

TICN

Applications – Material

P 1.1-3.1	K 1.1-4.2	P 1.1-3.1	M 1.1-2.1
N 1.1-5	N 2.1-6	K 1.1-4.2	N 1.1-2.7
N 3.1-4.2, 5.2	S 1.1-2	N 3.1-5.2	S 1.1-2, 2.1

MF

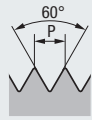

ISO Metric Fine Thread DIN 13

Thread Depth

1.5 x D

Tool Identification

GF322101

GF322106

Nominal Size	θD	P mm	l ₁	l ₂	l ₃	mm				Flutes	Dimens. ID
						θd_1	θd_5	l _s	θd_2		
M 6 x 0.75	62	9.4	36	5	6.3	10	8	3	.0229		
M 8 x 1	74	12.5	40	6.7	8.3	13.2	10	3	.0251		
M 10 x 1	80	15.5	45	8.7	10.3	16.2	12	3	.0276		
M 10 x 1.25	80	15.7	45	8.4	10.3	16.5	12	3	.0277		
M 12 x 1	90	18.5	45	10.6	12.3	19.3	14	4	.0301		
M 12 x 1.25	90	18.2	45	10.4	12.3	19	14	4	.0302		
M 12 x 1.5	90	18.8	45	10.1	12.3	19.7	14	4	.0303		
M 14 x 1.5	100	21.8	48	12.1	14.3	22.7	16	4	.0331		
M 16 x 1.5	102	24.8	48	14	16.3	25.8	18	4	.0359		

GSF-VHM
1.5xD
R30-1KZ-HB

GSF-VHM
1.5xD
R30-1KZ-HB
TICN

M 6 x 0.75	•	•
M 8 x 1	•	•
M 10 x 1	•	•
M 10 x 1.25	•	•
M 12 x 1	•	•
M 12 x 1.25	•	•
M 12 x 1.5	•	•
M 14 x 1.5	•	•
M 16 x 1.5	•	•

Thread Depth

2 x D

Tool Identification

GF332101

GF332106

Nominal Size	θD	P mm	l ₁	l ₂	l ₃	mm				Flutes	Dimens. ID
						θd_1	θd_5	l _s	θd_2		
M 6 x 0.75	62	12.4	36	5	6.3	13	8	3	.0229		
M 8 x 1	74	16.5	40	6.7	8.3	17.2	10	3	.0251		
M 10 x 1	80	20.5	45	8.7	10.3	21.2	12	3	.0276		
M 10 x 1.25	80	20.7	45	8.4	10.3	21.5	12	3	.0277		
M 12 x 1	90	24.5	45	10.6	12.3	25.3	14	4	.0301		
M 12 x 1.25	90	24.4	45	10.4	12.3	25.2	14	4	.0302		
M 12 x 1.5	90	24.8	45	10.1	12.3	25.7	14	4	.0303		
M 14 x 1.5	100	29.3	48	12.1	14.3	30.2	16	4	.0331		
M 16 x 1.5	102	32.3	48	14	16.3	33.3	18	4	.0359		

GSF-VHM
2xD
R30-1KZ-HB

GSF-VHM
2xD
R30-1KZ-HB
TICN

M 6 x 0.75	•	•
M 8 x 1	•	•
M 10 x 1	•	•
M 10 x 1.25	•	•
M 12 x 1	•	•
M 12 x 1.25	•	•
M 12 x 1.5	•	•
M 14 x 1.5	•	•
M 16 x 1.5	•	•

Other sizes upon request

Metric Shank

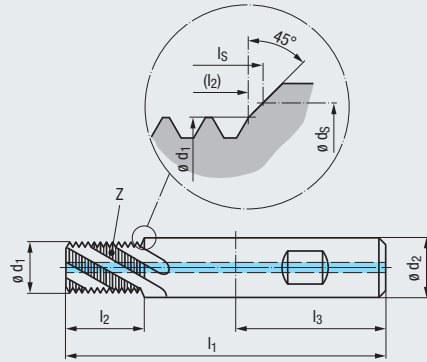

Carbide

R15 RH + LH

4-5 Flutes **DIN 6535**
 HB HE HA

90° ϕD

With increased number of flutes



Coating

TICN

Applications – Material

P 1.1-5.1 **M** 1.1-4.1
K 1.1-4.2 **N** 1.1-5.2
S 1.1-2.6 **H** 1.1-2

Thread Depth

2 x D



**ISO Metric Fine Thread
 DIN 13**

Tool Identification

GF335126

Nominal Size	ϕD	P mm	l_1	l_2	l_3	mm				Flutes	Dimens. ID
						ϕd_1	ϕd_s	l_s	ϕd_2		
M 8 x 1			74	16.5	40	6.7	8.3	17.2	10	4	.0251
M 10 x 1			80	20.5	45	8.7	10.3	21.2	12	5	.0276
M 12 x 1.25			90	24.4	45	10.4	12.3	25.2	14	5	.0302

GSF-Z-VHM
 2xD
 R15-IKZ-HB
 TICN

●
 ●
 ●

Other sizes upon request

Product Finder

v_c / f_z

UNC

UNF

UN

M

MF

NPSF

Rp (BSPP)

G

W

BSW, BSF

NPT

NPTF

Rc (BSPT)

STI

SELF-LOCK

Accessories

Tech. Info

BGF

ZBGF

GSF (Aero)

GSF-Z

GF(I), GF-Z

GF-Vario-Z

GF-H

GF(I)-KEG

ZGF(I)

CIRC-GF

Gigant

FPC, FMC

MoSys



Need programming assistance?

EMUGE's trained thread milling specialist can assist you with advice and guidance in writing the correct program for your CNC machine tool. Thread milling experts will analyze your exact application and help guide you through the proper line code programming.

Contact EMUGE Technical Support department or visit www.emuge.com

- Product Finder
- v_c / f_z
- UNC
- UNF
- UN
- M
- MF
- NPSF
- Rp (BSPP)
- G**
- W
- BSW, BSF
- NPT
- NPTF
- Rc (BSPT)
- STI
- SELF-LOCK
- Accessories
- Tech. Info

Metric Shank

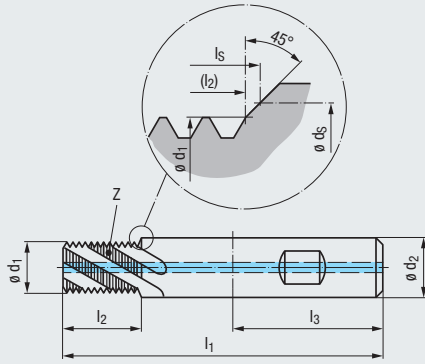

Carbide

R30

RH + LH

3-4 Flutes



DIN 6535



90°



ϕD



Coating

TICN

Applications – Material

P	1.1-3.1	K	1.1-4.2	P	1.1-3.1	M	1.1-2.1
N	1.1-5	N	2.1-6	K	1.1-4.2	N	1.1-2.7
N	3.1-4.2, 5.2	S	1.1-2	N	3.1-5.2	S	1.1-2, 2.1

G

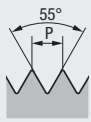

Whitworth Pipe Thread DIN EN ISO 228

Thread Depth

1.5 x D

Tool Identification

GF322101

GF322106

Nominal Size	ϕD	T.P.I.	l_1	l_2	inch			l_s	ϕd_2		Flutes	Dimens. ID
					ϕd_1	ϕd_s	l_3		inch	mm		
G 1/8	28	3.150	0.591	1.772	0.323	0.394	0.618	0.472	12	3	.4035	
G 1/4	19	3.937	0.815	1.890	0.433	0.531	0.858	0.630	16	4	.4036	
G 3/8	19	4.016	1.028	1.890	0.571	0.669	1.071	0.709	18	4	.4037	

GSF-VHM
1.5xD
R30-1KZ-HB

GSF-VHM
1.5xD
R30-1KZ-HB
TICN

Thread Depth

2 x D

Tool Identification

GF332101

GF332106

Nominal Size	ϕD	T.P.I.	l_1	l_2	inch			l_s	ϕd_2		Flutes	Dimens. ID
					ϕd_1	ϕd_s	l_3		inch	mm		
G 1/8	28	3.150	0.803	1.772	0.323	0.394	0.835	0.472	12	3	.4035	
G 1/4	19	3.937	1.079	1.890	0.433	0.531	1.122	0.630	16	4	.4036	
G 3/8	19	4.016	1.343	1.890	0.571	0.669	1.386	0.709	18	4	.4037	

GSF-VHM
2xD
R30-1KZ-HB

GSF-VHM
2xD
R30-1KZ-HB
TICN

Other sizes upon request

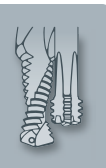

Metric Shank

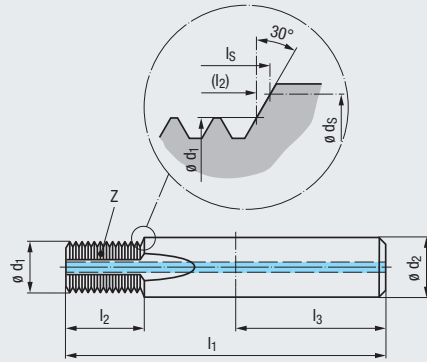

Carbide

RH + LH

3-4 Flutes



DIN 6535



LK-M

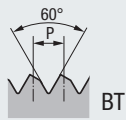

**Metric SELF-LOCK Coarse Thread
EMUGE Standard**

Coating

TICN

Applications – Material

P	1.1-5.1	K	1.1-4.2	P	1.1-5.1	M	1.1-4.1
N	1.1-5, 2.1-6	N	3.1-2	K	1.1-4.2	N	1.1-5.2
N	4.1-2, 5.2	S	1.1-3	S	1.1-2.6	H	1.1-2

Thread Depth

2 x D

Tool Identification

											GF333101	GF333106	
											GSF-VHM 2xD IKZ-HB	GSF-VHM 2xD IKZ-HB TICN	
Nominal Size	ϕD	P mm	l_1	l_2	l_3	mm		l_s	ϕd_2	Flutes	Dimens. ID		
LK-M 5	5	0.8	55	10.7	36	4	5.3	11.1	6	3	.1050	●	●
LK-M 6	6	1	62	12.4	36	4.8	6.3	12.8	8	3	.1052	●	●
LK-M 8	8	1.25	74	16.7	40	6.5	8.3	17.3	10	3	.1054	●	●
LK-M 10	10	1.5	80	20.1	45	8.2	10.3	20.7	12	3	.1056	●	●
LK-M 12	12	1.75	90	25.2	45	9.9	12.3	25.9	14	4	.1058	●	●

Other sizes upon request

Product Finder

v_c / f_z

UNC

UNF

UN

M

MF

NPSF

Rp (BSPP)

G

W

BSW, BSF

NPT

NPTF

Rc (BSPT)

STI

SELF-LOCK

Accessories

Tech. Info

BGF

ZBGF

GSF

GSF-Z

GF(I), GF-Z

GF-Vario-Z

GF-H

GF(I)-KEG

ZGF(I)

CIRC-GF

Gigant

FPC, FMC

MoSys

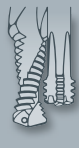

Product Finder

- v_c / f_z
- UNC
- UNF
- UN
- M
- MF
- NPSF
- Rp (BSPP)
- G
- W
- BSW, BSF
- NPT
- NPTF
- Rc (BSPT)
- STI
- SELF-LOCK
- Accessories
- Tech. Info
- BGF
- ZBGF
- GSF (Aero)
- GSF-Z
- GF(I), GF-Z
- GF-Vario-Z
- GF-H
- GF(I)-KEG
- ZGF(I)
- CIRC-GF
- Gigant
- FPC, FMC
- MoSys

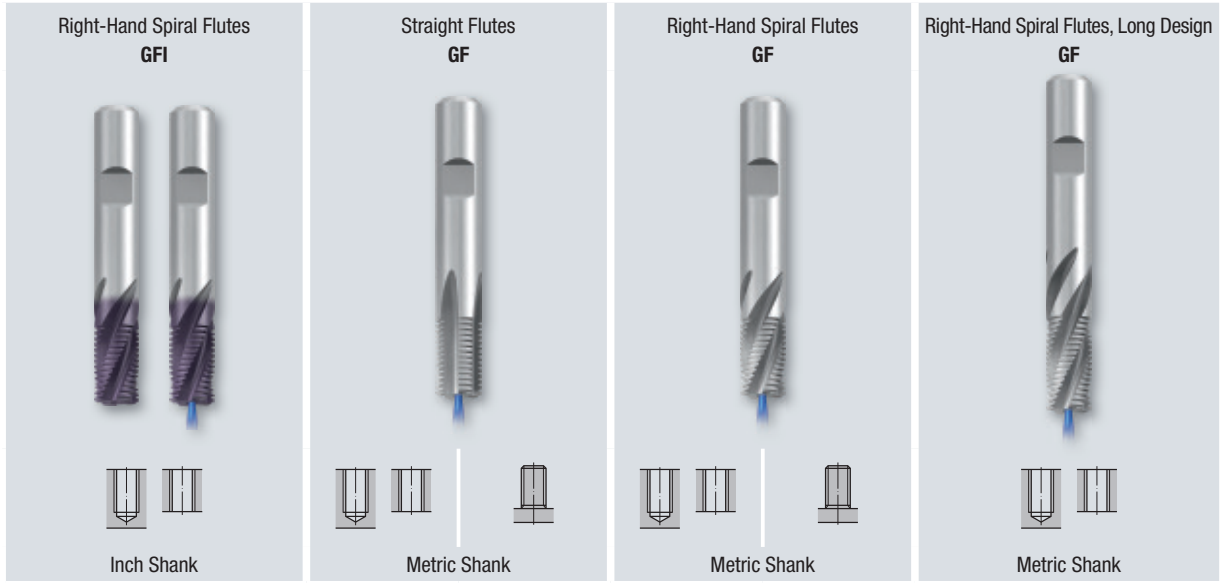

Page

UNC	264				
UNF	265				
UN		266		267	
M	270	271	274	272	273
MF		271	274	272	273
G (BSP), Rp (BSPP), W		279	279	280	280
NPSF				282	
LK-M, LK-MF		283			

Possible modifications



For a description of these modifications, see page 357

Thread milling cycle
GF, GF-Z

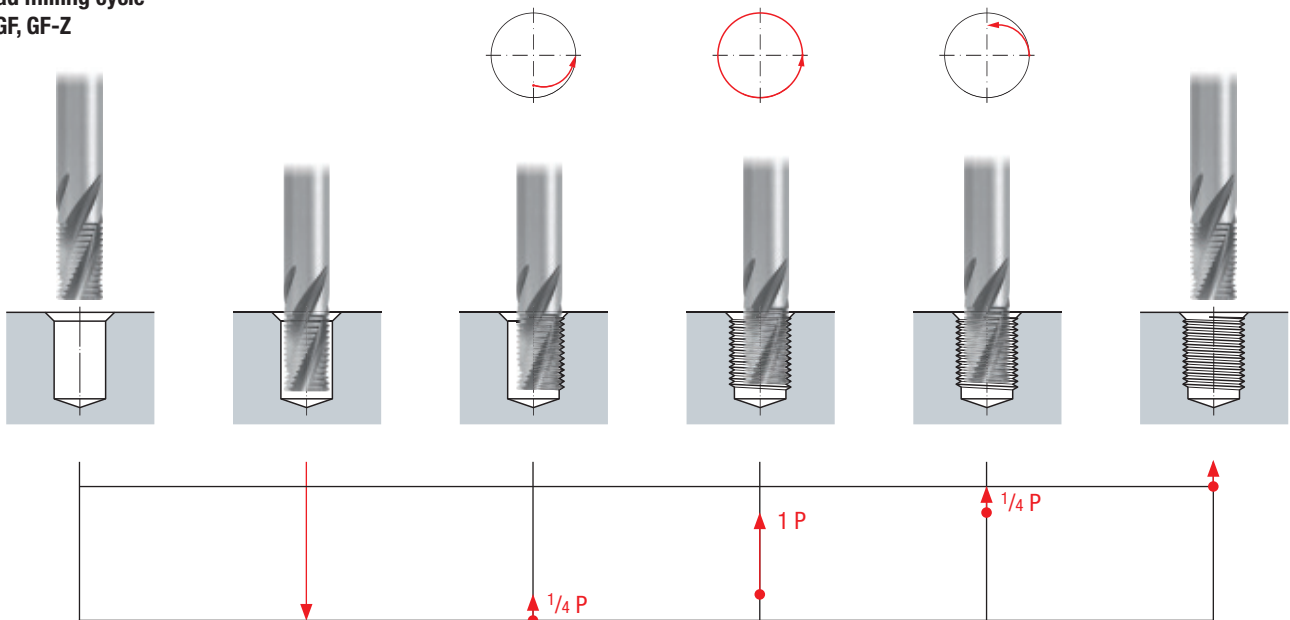

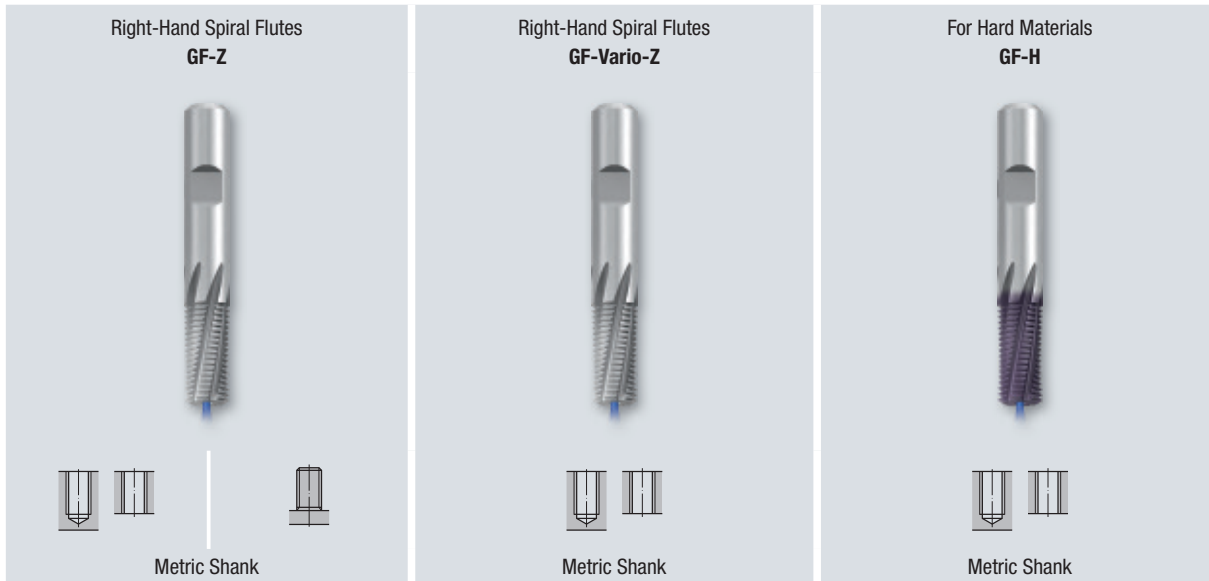

		Page		
		268		UNC
		269		UNF
		268, 269		UN
275		276	278	M
275		276, 277		MF
281	281			G (BSP), Rp (BSPP), W
				NPSF
				LK-M, LK-MF

- Product Finder
- v_c / f_z
- UNC
- UNF
- UN
- M
- MF
- NPSF
- Rp (BSPP)
- G
- W
- BSW, BSF
- NPT
- NPTF
- Rc (BSPT)
- STI
- SELF-LOCK
- Accessories
- Tech. Info
- BGF
- ZBGF
- GSF (Aero)
- GSF-Z
- GF(I), GF-Z
- GF-Vario-Z
- GF-H
- GF(I)-KEG
- ZGF(I)
- CIRC-GF
- Gigant
- FPC, FMC
- MoSys

Possible modifications



For a description of these modifications, see page 357

**Thread milling cycle
GF-Vario-Z, GF-H**

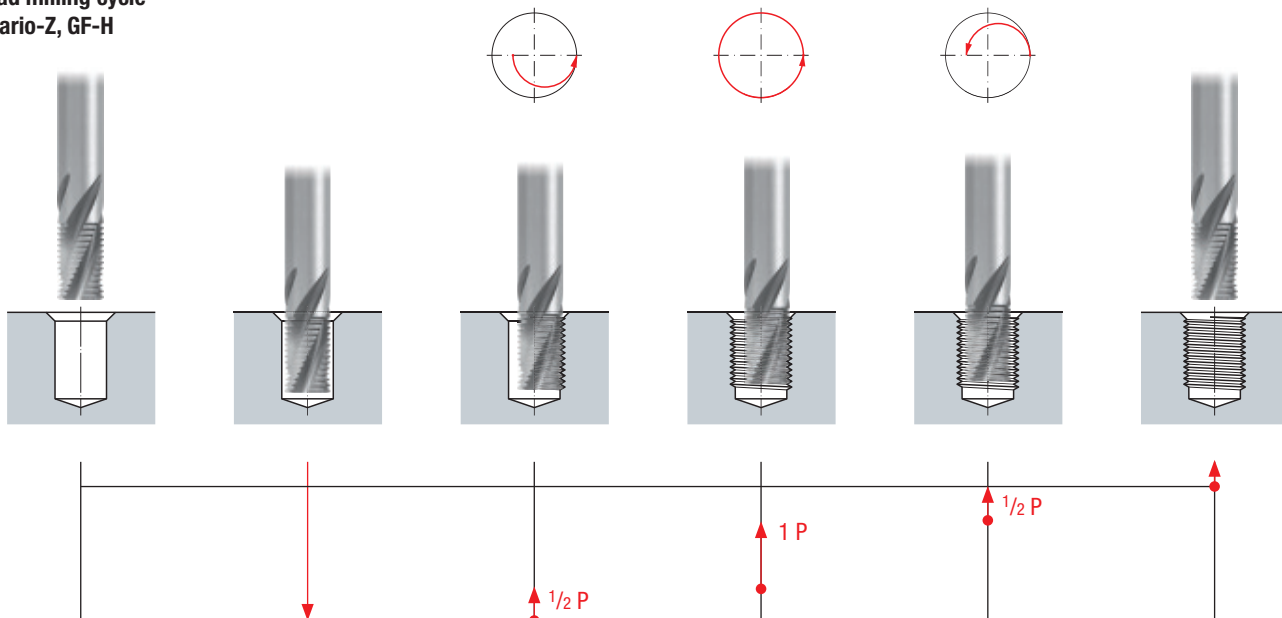

- Product Finder
- v_c / f_z
- UNC
- UNF
- UN
- M
- MF
- NPSF
- Rp (BSPP)
- G
- W
- BSW, BSF
- NPT
- NPTF
- Rc (BSPT)
- STI
- SELF-LOCK
- Accessories
- Tech. Info

Inch Shank

Carbide

R15

RH + LH

3-4 Flutes

ASME B94.19



For internal threads

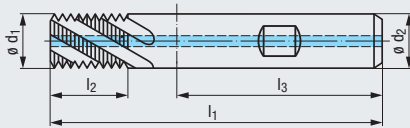

Without internal coolant supply (IKZ)



With internal coolant supply (IKZ)



Coating

TICN

TICN

Applications – Material

P	1.1-5.1	M	1.1-4.1	P	1.1-5.1	M	1.1-4.1
K	1.1-4.2	N	1.1-5.2	K	1.1-4.2	N	1.1-5.2
S	1.1-2.6	H	1.1-2	S	1.1-2.6	H	1.1-2

UNC

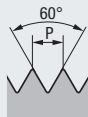

Unified Coarse Thread
ASME B1.1

Nominal Size	ϕD	T.P.I.	ϕd_1	l_1	inch	l_2	l_3	ϕd_2	Flutes	GFI-VHM R15-HB TICN		GFI-VHM R15-IKZ-HB TICN	
No. 10		24	0.136	2 1/2	0.395	1 3/8	1/4	3	GFR15106.5007	●	GFR35106.5007	●	
1/4		20	0.185	2 1/2	0.524	1 3/8	1/4	3	GFR15106.5009	●	GFR35106.5009	●	
5/16		18	0.242	2 1/2	0.637	1 3/8	1/4	3	GFR15106.5010	●	GFR35106.5010	●	
3/8		16	0.301	2 1/2	0.780	1 3/8	5/16	3	GFR15106.5011	●	GFR35106.5011	●	
7/16		14	0.354	3	0.891	1 9/16	3/8	3	GFR15106.5012	●	GFR35106.5012	●	
1/2		13	0.371	3	1.036	1 9/16	3/8	3	GFR15106.5013	●	GFR35106.5013	●	
5/8		11	0.496	3 3/4	1.316	1 25/32	1/2	4	GFR15106.5015	●	GFR35106.5015	●	
3/4		10	0.621	4 1/4	1.548	1 29/32	5/8	4	GFR15106.5016	●	GFR35106.5016	●	
7/8		9	0.621	4 1/4	1.829	1 29/32	5/8	4	GFR15106.5017	●	GFR35106.5017	●	
1		8	0.746	4 3/4	2.058	2 1/32	3/4	4	GFR15106.5018	●	GFR35106.5018	●	
1 1/8		8											

Tools for different thread pitch upon request

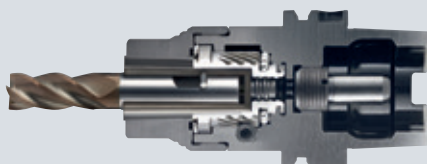
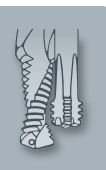

Improve the thread milling process by using a rigid tool holder. The EMUGE FPC chuck provides the accuracy of a shrink-fit holder with the convenience of an hydraulic chuck. See page 338 - 349 for more information.

Inch Shank

Carbide

R15

RH + LH

3-4 Flutes



ASME B94.19

ø D



Without internal coolant supply (IKZ)



With internal coolant supply (IKZ)



For internal threads

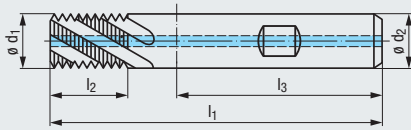

Coating

TICN

TICN

Applications – Material

P 1.1-5.1
K 1.1-4.2
S 1.1-2.6

M 1.1-4.1
N 1.1-5.2
H 1.1-2

P 1.1-5.1
K 1.1-4.2
S 1.1-2.6

M 1.1-4.1
N 1.1-5.2
H 1.1-2

UNF



Unified Fine Thread
ASME B1.1

Nominal Size

ø D	T.P.I.	ø d ₁	l ₁	inch l ₂	l ₃	ø d ₂	Flutes
No. 10	32	0.150	2 1/2	0.390	1 3/8	1/4	3
1/4	28	0.203	2 1/2	0.517	1 3/8	1/4	3
5/16	24	0.246	2 1/2	0.644	1 3/8	1/4	3
3/8	24	0.309	2 1/2	0.769	1 3/8	5/16	3
7/16	20	0.371	3	0.874	1 9/16	3/8	3
1/2	20	0.371	3	1.023	1 9/16	3/8	3
9/16	18	0.496	3 3/4	1.138	1 25/32	1/2	4
5/8	18						
3/4	16	0.621	4 1/4	1.530	1 29/32	5/8	4
7/8	14	0.621	4 1/4	1.817	1 29/32	5/8	4
1	14						

GFI-VHM
R15-HB
TICN

- GFR15106.5041 ●
- GFR15106.5043 ●
- GFR15106.5044 ●
- GFR15106.5045 ●
- GFR15106.5046 ●
- GFR15106.5047 ●

GFI-VHM
R15-**IKZ**-HB
TICN

- GFR35106.5041 ●
- GFR35106.5043 ●
- GFR35106.5044 ●
- GFR35106.5045 ●
- GFR35106.5046 ●
- GFR35106.5047 ●
- GFR35106.5048 ●
- GFR35106.5050 ●
- GFR35106.5051 ●

Tools for different thread pitch upon request

Product Finder

v_c / f_z

UNC

UNF

UN

M

MF

NPSF

Rp (BSPP)

G

W

BSW, BSF

NPT

NPTF

Rc (BSPT)

STI

SELF-LOCK

Accessories

Tech. Info

BGF

ZBGF

GSF (Aero)

GSF-Z

GFI, GF-Z

GF-Vario-Z

GF-H

GF(I)-KEG

ZGF(I)

CIRC-GF

Gigant

FPC, FMC

MoSys



- Product Finder
- v_c / f_z
- UNC
- UNF
- UN
- M
- MF
- NPSF
- Rp (BSPP)
- G
- W
- BSW, BSF
- NPT
- NPTF
- Rc (BSPT)
- STI
- SELF-LOCK
- Accessories
- Tech. Info
- BGF
- ZBGF
- GSF (Aero)
- GSF-Z
- GF(I), GF-Z
- GF-Vario-Z
- GF-H
- GF(I)-KEG
- ZGF(I)
- CIRC-GF
- Gigant
- FPC, FMC
- MoSys

Metric Shank

For internal threads

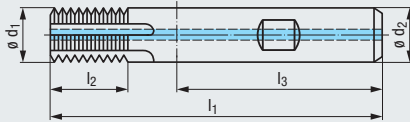

Carbide

RH + LH

4-5 Flutes



DIN 6535



Coating

TICN

Applications – Material

P	1.1-5.1	K	1.1-4.2	P	1.1-5.1	M	1.1-4.1
N	1.1-5, 2.1-6	N	3.1-2	K	1.1-4.2	N	1.1-5.2
N	4.1-2, 5.2	S	1.1-3	S	1.1-2.6	H	1.1-2

UN

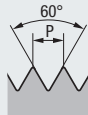

Unified Threads
ASME B1.1

T.P.I.	$\phi D_{min.}$	ϕd_1	inch			inch		Flutes	GF-VHM IKZ-HB		GF-VHM IKZ-HB TICN	
			l_1	l_2	l_3	ϕd_2	mm					
24	1/2	0.390	2.756	0.642	1.575	0.394	10	4	GF163211.9579	●	GF163216.9579	●
20	1/2	0.390	2.756	0.673	1.575	0.394	10	4	GF163211.9580	●	GF163216.9580	●
20	11/16	0.469	3.150	0.823	1.772	0.472	12	4	GF163121.9580	●	GF163126.9580	●
20	7/8	0.626	3.543	1.020	1.890	0.630	16	5	GF163131.9580	●	GF163136.9580	●
20	1	0.783	4.134	1.272	1.969	0.787	20	5	GF163151.9580	●	GF163156.9580	●
18	1/2	0.390	2.756	0.689	1.575	0.394	10	4	GF163211.9581	●	GF163216.9581	●
16	1/2	0.390	2.756	0.654	1.575	0.394	10	4	GF163211.9582	●	GF163216.9582	●
16	11/16	0.469	3.150	0.839	1.772	0.472	12	4	GF163121.9582	●	GF163126.9582	●
16	7/8	0.626	3.543	1.031	1.890	0.630	16	5	GF163131.9582	●	GF163136.9582	●
16	1	0.783	4.134	1.276	1.969	0.787	20	5	GF163151.9582	●	GF163156.9582	●
14	7/8	0.626	3.543	1.031	1.890	0.630	16	5	GF163131.9583	●	GF163136.9583	●
12	11/16	0.469	3.150	0.870	1.772	0.472	12	4	GF163121.9585	●	GF163126.9585	●
12	7/8	0.626	3.543	1.035	1.890	0.630	16	5	GF163131.9585	●	GF163136.9585	●
12	1	0.783	4.134	1.287	1.969	0.787	20	5	GF163151.9585	●	GF163156.9585	●
10	11/16	0.469	3.150	0.843	1.772	0.472	12	4	GF163121.9587	●	GF163126.9587	●
9	11/16	0.469	3.150	0.827	1.772	0.472	12	4	GF163121.9588	●	GF163126.9588	●
8	7/8	0.626	3.543	1.055	1.890	0.630	16	5	GF163131.9589	●	GF163136.9589	●
8	1	0.783	4.134	1.307	1.969	0.787	20	5	GF163151.9589	●	GF163156.9589	●
6	1	0.783	4.134	1.409	1.969	0.787	20	5	GF163151.9591	●	GF163156.9591	●

Tools for different thread pitch upon request



Metric Shank

Carbide

R30

RH + LH

4-5 Flutes



DIN 6535



For internal threads

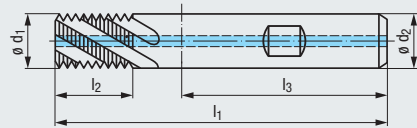

UN
Unified Threads
ASME B1.1

Coating

TICN

Applications – Material

P	1.1-3.1	K	1.1-4.2	P	1.1-3.1	M	1.1-2.1
N	1.1-5	N	2.1-6	K	1.1-4.2	N	1.1-2.7
N	3.1-4.2, 5.2	S	1.1-2	N	3.1-5.2	S	1.1-2, 2.1

T.P.I.	$\phi D_{min.}$	ϕd_1	inch			ϕd_2	mm	Flutes	GF-VHM R30-Ig-IKZ-HB		GF-VHM R30-Ig-IKZ-HB TICN	
			l_1	l_2	l_3							
24	1/2	0.390	3.150	0.811	1.575	0.394	10	4	GF162311.9579	●	GF162316.9579	●
20	1/2	0.390	3.150	0.823	1.575	0.394	10	4	GF162311.9580	●	GF162316.9580	●
20	11/16	0.469	3.543	1.024	1.772	0.472	12	4	GF162321.9580	●	GF162326.9580	●
20	7/8	0.626	3.937	1.272	1.890	0.630	16	5	GF162331.9580	●	GF162336.9580	●
20	1	0.783	4.528	1.622	1.969	0.787	20	5	GF162351.9580	●	GF162356.9580	●
18	1/2	0.390	3.150	0.803	1.575	0.394	10	4	GF162311.9581	●	GF162316.9581	●
16	1/2	0.390	3.150	0.839	1.575	0.394	10	4	GF162311.9582	●	GF162316.9582	●
16	11/16	0.469	3.543	1.028	1.772	0.472	12	4	GF162321.9582	●	GF162326.9582	●
16	7/8	0.626	3.937	1.276	1.890	0.630	16	5	GF162331.9582	●	GF162336.9582	●
16	1	0.783	4.528	1.591	1.969	0.787	20	5	GF162351.9582	●	GF162356.9582	●
14	7/8	0.626	3.937	1.315	1.890	0.630	16	5	GF162331.9583	●	GF162336.9583	●
12	11/16	0.469	3.543	1.035	1.772	0.472	12	4	GF162321.9585	●	GF162326.9585	●
12	7/8	0.626	3.937	1.287	1.890	0.630	16	5	GF162331.9585	●	GF162336.9585	●
12	1	0.783	4.528	1.618	1.969	0.787	20	5	GF162351.9585	●	GF162356.9585	●
10	11/16	0.469	3.543	1.043	1.772	0.472	12	4	GF162321.9587	●	GF162326.9587	●
9	11/16	0.469	3.543	1.047	1.772	0.472	12	4	GF162321.9588	●	GF162326.9588	●
8	7/8	0.626	3.937	1.303	1.890	0.630	16	5	GF162331.9589	●	GF162336.9589	●
8	1	0.783	4.528	1.681	1.969	0.787	20	5	GF162351.9589	●	GF162356.9589	●
6	1	0.783	4.528	1.744	1.969	0.787	20	5	GF162351.9591	●	GF162356.9591	●

Tools for different thread pitch upon request

● = In stock
★ = Allow 7 days for delivery

Product Finder

v_c / f_z

UNC

UNF

UN

M

MF

NPSF

Rp (BSPP)

G

W

BSW, BSF

NPT

NPTF

Rc (BSPT)

STI

SELF-LOCK

Accessories

Tech. Info

BGF

ZBGF

GSF (Aero)

GSF-Z

GF(I), GF-Z

GF-Vario-Z

GF-H

GF(I)-KEG

ZGF(I)

CIRC-GF

Gigant

FPC, FMC

MoSys



- Product Finder
- v_c / f_z
- UNC
- UNF
- UN
- M
- MF
- NPSF
- Rp (BSPP)
- G
- W
- BSW, BSF
- NPT
- NPTF
- Rc (BSPT)
- STI
- SELF-LOCK
- Accessories
- Tech. Info
- BGF
- ZBGF
- GSF (Aero)
- GSF-Z
- GF(I), GF-Z
- GF-Vario-Z
- GF-H
- GF(I)-KEG
- ZGF(I)
- CIRC-GF
- Gigant
- FPC, FMC
- MoSys

Metric Shank

For internal threads

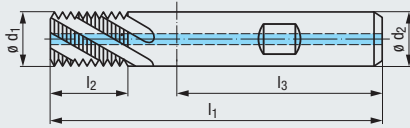

Carbide

R15

RH + LH

4-6 Flutes



DIN 6535



With increased number of flutes



new

Coating

TICN

Applications – Material

- P 1.1-5.1
- M 1.1-4.1
- K 1.1-4.2
- N 1.1-5.2
- S 1.1-2.6
- H 1.1-2

UNC, UN

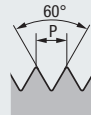

Unified Coarse Threads
ASME B1.1

T.P.I.	$\varnothing D_{min.}$	$\varnothing d_1$	inch			$\varnothing d_2$	mm	Flutes	GF-VZ-VHM R15-IKZ-HB TICN
			l_1	l_2	l_3				
24	\geq No. 10	0.146	2.165	0.394	1.417	0.236	6	4	GFB35106.5007
20	\geq 1/4	0.195	2.283	0.524	1.417	0.236	6	4	GFB35106.5009
18	\geq 5/16	0.248	2.441	0.638	1.417	0.315	8	4	GFB35106.5010
16	\geq 3/8	0.301	2.559	0.780	1.417	0.315	8	5	GFB35106.5011
14	\geq 7/16	0.354	2.913	0.890	1.575	0.394	10	5	GFB35106.5012
13	\geq 1/2	0.409	3.150	1.035	1.772	0.472	12	5	GFB35106.5013
12	\geq 9/16	0.465	3.346	1.205	1.772	0.472	12	5	GFB35106.5014
11	\geq 5/8	0.512	3.543	1.315	1.772	0.551	14	5	GFB35106.5015
10	\geq 3/4	0.626	3.937	1.547	1.890	0.630	16	5	GFB35106.5016
9	\geq 7/8	0.744	4.331	1.831	1.969	0.787	20	6	GFB35106.5017
8	\geq 1	0.850	4.921	2.059	2.205	0.984	25	6	GFB35106.5018

Tools for different thread pitch upon request

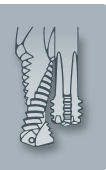

Metric Shank

Carbide

R15

RH + LH

4-8 Flutes



DIN 6535



new

With increased number of flutes



For internal threads

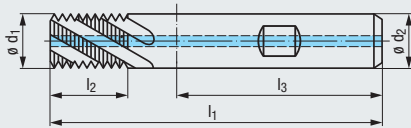

Coating

TICN

Applications – Material

- P 1.1-5.1 M 1.1-4.1
- K 1.1-4.2 N 1.1-5.2
- S 1.1-2.6 H 1.1-2

UNF, UN

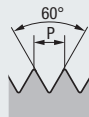

Unified Fine Threads
ASME B1.1

T.P.I.	ø D _{min.}	ø d ₁	inch			inch		Flutes	GF-VZ-VHM R15-1KZ-HB TICN	
			l ₁	l ₂	l ₃	ø d ₂	mm			
32	≥ No. 10	0.154	2.165	0.390	1.417	0.236	6	4	GFB35106.5041	●
28	≥ No. 12	0.175	2.283	0.445	1.417	0.236	6	4	GFB35106.5042	●
28	≥ 1/4	0.209	2.283	0.516	1.417	0.236	6	4	GFB35106.5043	●
24	≥ 5/16	0.260	2.441	0.646	1.417	0.315	8	5	GFB35106.5044	●
20	≥ 7/16	0.376	2.913	0.874	1.575	0.394	10	6	GFB35106.5046	●
18	≥ 9/16	0.492	3.346	1.138	1.772	0.551	14	7	GFB35106.5048	●
16	≥ 3/4	0.669	4.016	1.528	1.890	0.709	18	8	GFB35106.5050	●

Tools for different thread pitch upon request

Product Finder

v_c / f_z

UNC

UNF

UN

M

MF

NPSF

Rp (BSPP)

G

W

BSW, BSF

NPT

NPTF

Rc (BSPT)

STI

SELF-LOCK

Accessories

Tech. Info

BGF

ZBGF

GSF (Aero)

GSF-Z

GF(I), GF-Z

GF-Vario-Z

GF-H

GF(I)-KEG

ZGF(I)

CIRC-GF

Gigant

FPC, FMC

MoSys

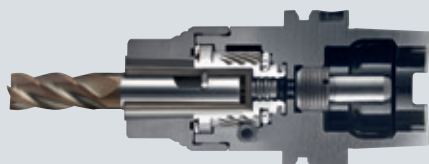

Improve the thread milling process by using a rigid tool holder. The EMUGE FPC chuck provides the accuracy of a shrink-fit holder with the convenience of an hydraulic chuck. See page 338 - 349 for more information.

● = In stock
★ = Allow 7 days for delivery

- Product Finder
- v_c / f_z
- UNC
- UNF
- UN
- M**
- MF
- NPSF
- Rp (BSPP)
- G
- W
- BSW, BSF
- NPT
- NPTF
- Rc (BSPT)
- STI
- SELF-LOCK
- Accessories
- Tech. Info
- BGF
- ZBGF
- GSF (Aero)
- GSF-Z
- GFI GF-Z**
- GF-Vario-Z
- GF-H
- GF(l)-KEG
- ZGF(l)
- CIRC-GF
- Gigant
- FPC, FMC
- MoSys

Inch Shank

Carbide

Without internal coolant supply (IKZ)

R15

RH + LH

3 Flutes

ASME
B94.19

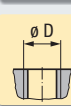

For internal threads

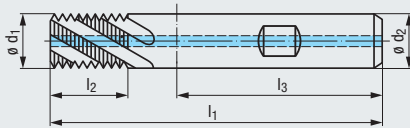

Coating

TICN

Applications – Material

- P** 1.1-5.1 **M** 1.1-4.1
- K** 1.1-4.2 **N** 1.1-5.2
- S** 1.1-2.6 **H** 1.1-2

M



ISO Metric Coarse Thread
DIN 13

Nominal Size	ø D	P mm	ø d ₁	l ₁	inch l ₂	l ₃	ø d ₂	Flutes	GFI-VHM R15-HB TICN	
M 6	6	1	0.189	2 1/2	0.491	1 3/8	1/4	3	GFR15106.0060	●
M 8	8	1.25	0.246	2 1/2	0.663	1 3/8	1/4	3	GFR15106.0080	●
M 10	10	1.5	0.309	2 1/2	0.796	1 3/8	5/16	3	GFR15106.0100	●
M 12	12	1.75	0.371	3	0.997	1 9/16	3/8	3	GFR15106.0112	●

Tools for different thread pitch upon request

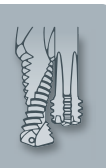

Metric Shank

Carbide

RH + LH

3-5 Flutes



DIN 6535



For internal threads

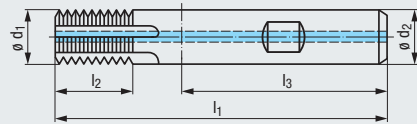

Coating

TICN

Applications – Material

P	1.1-5.1	K	1.1-4.2	P	1.1-5.1	M	1.1-4.1
N	1.1-5, 2.1-6	N	3.1-2	K	1.1-4.2	N	1.1-5.2
N	4.1-2, 5.2	S	1.1-3	S	1.1-2.6	H	1.1-2

M, MF

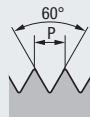

ISO Metric Thread
DIN 13

P mm	$\varnothing D_{min.}$	$\varnothing d_1$	l_1	mm		$\varnothing d_2$	Flutes	GF-VHM IKZ-HB		GF-VHM IKZ-HB TICN	
				l_2	l_3						
0.5	10	7.9	63	12.2	36	8	3	GF163101.9506	●	GF163106.9506	●
0.5	12	9.9	70	16.2	40	10	4	GF163211.9506	●	GF163216.9506	●
0.75	11	7.9	63	12.3	36	8	3	GF163101.9509	●	GF163106.9509	●
0.75	13	9.9	70	16.8	40	10	4	GF163211.9509	●	GF163216.9509	●
1	14	9.9	70	16.4	40	10	4	GF163211.9512	●	GF163216.9512	●
1	16	11.9	80	20.4	45	12	4	GF163121.9512	●	GF163126.9512	●
1	22	15.9	90	25.4	48	16	5	GF163131.9512	●	GF163136.9512	●
1	27	19.9	105	32.4	50	20	5	GF163151.9512	●	GF163156.9512	●
1.5	14	9.9	70	17.1	40	10	4	GF163211.9514	●	GF163216.9514	●
1.5	16	11.9	80	21.6	45	12	4	GF163121.9514	●	GF163126.9514	●
1.5	22	15.9	90	26.1	48	16	5	GF163131.9514	●	GF163136.9514	●
1.5	27	19.9	105	33.6	50	20	5	GF163151.9514	●	GF163156.9514	●
2	18	11.9	80	20.9	45	12	4	GF163121.9516	●	GF163126.9516	●
2	22	15.9	90	26.9	48	16	5	GF163131.9516	●	GF163136.9516	●
2	27	19.9	105	32.9	50	20	5	GF163151.9516	●	GF163156.9516	●
3	24	15.9	90	28.3	48	16	5	GF163131.9518	●	GF163136.9518	●
3	30	19.9	105	34.3	50	20	5	GF163151.9518	●	GF163156.9518	●

Tools for different thread pitch upon request

- Product Finder
- v_c / f_z
- UNC
- UNF
- UN
- M
- MF
- NPSF
- Rp (BSPP)
- G
- W
- BSW, BSF
- NPT
- NPTF
- Rc (BSPT)
- STI
- SELF-LOCK
- Accessories
- Tech. Info

- BGF
- ZBGF
- GSF (Aero)
- GSF-Z
- GF(I), GF-Z
- GF-Vario-Z
- GF-H
- GF(I)-KEG
- ZGF(I)
- CIRC-GF
- Gigant
- FPC, FMC
- MoSys



● = In stock
★ = Allow 7 days for delivery

- Product Finder
- v_c / f_z
- UNC
- UNF
- UN
- M
- MF
- NPSF
- Rp (BSPP)
- G
- W
- BSW, BSF
- NPT
- NPTF
- Rc (BSPT)
- STI
- SELF-LOCK
- Accessories
- Tech. Info
- BGF
- ZBGF
- GSF (Aero)
- GSF-Z
- GF(I), GF-Z
- GF-Vario-Z
- GF-H
- GF(I)-KEG
- ZGF(I)
- CIRC-GF
- Gigant
- FPC, FMC
- MoSys

Metric Shank

Carbide

R30

RH + LH

3-5 Flutes

DIN 6535



new



new



For internal threads

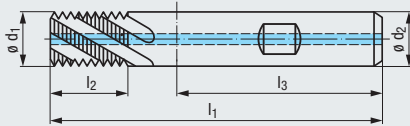

Coating

TICN

Applications – Material

P	1.1-3.1	K	1.1-4.2	P	1.1-3.1	M	1.1-2.1
N	1.1-5	N	2.1-6	K	1.1-4.2	N	1.1-2.7
N	3.1-4.2, 5.2	S	1.1-2	N	3.1-5.2	S	1.1-2, 2.1

M, MF

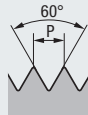

ISO Metric Threads
DIN 13

P mm	$\varnothing D_{min.}$	$\varnothing d_1$	l_1	mm		$\varnothing d_2$	Flutes	GF-VHM R30-1KZ-HB		GF-VHM R30-1KZ-HB TICN	
				l_2	l_3						
0.5	10	7.9	63	12.2	36	8	3	GF162101.9506	●	GF162106.9506	●
0.75	11	7.9	63	12.3	36	8	3	GF162101.9509	●	GF162106.9509	●
1	14	9.9	70	16.4	40	10	4	GF162211.9512	●	GF162216.9512	●
1	16	11.9	80	20.4	45	12	4	GF162121.9512	●	GF162126.9512	●
1	22	15.9	90	25.4	48	16	5	GF162131.9512	●	GF162136.9512	●
1	27	19.9	105	32.4	50	20	5	GF162151.9512	●	GF162156.9512	●
1.5	14	9.9	70	17.1	40	10	4	GF162211.9514	●	GF162216.9514	●
1.5	16	11.9	80	21.6	45	12	4	GF162121.9514	●	GF162126.9514	●
1.5	22	15.9	90	26.1	48	16	5	GF162131.9514	●	GF162136.9514	●
1.5	27	19.9	105	33.6	50	20	5	GF162151.9514	●	GF162156.9514	●
2	18	11.9	80	20.9	45	12	4	GF162121.9516	●	GF162126.9516	●
2	22	15.9	90	26.9	48	16	5	GF162131.9516	●	GF162136.9516	●
2	27	19.9	105	32.9	50	20	5	GF162151.9516	●	GF162156.9516	●
3	24	15.9	90	28.3	48	16	5	GF162131.9518	●	GF162136.9518	●
3	30	19.9	105	34.9	50	20	5	GF162151.9518	●	GF162156.9518	●

Tools for different thread pitch upon request

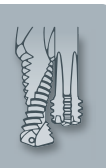

Metric Shank

Carbide

R30

RH + LH

4-5 Flutes



DIN 6535



For internal threads

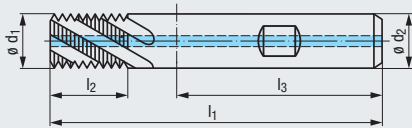

Coating

TICN

Applications – Material

P	1.1-3.1	K	1.1-4.2	P	1.1-3.1	M	1.1-2.1
N	1.1-5	N	2.1-6	K	1.1-4.2	N	1.1-2.7
N	3.1-4.2, 5.2	S	1.1-2	N	3.1-5.2	S	1.1-2, 2.1

M, MF

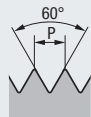

ISO Metric Threads
DIN 13

P mm	$\phi D_{min.}$	ϕd_1	l_1	mm		ϕd_2	Flutes	GF-VHM R30-Ig-IKZ-HB		GF-VHM R30-Ig-IKZ-HB TICN	
				l_2	l_3						
1	14	9.9	80	20.4	40	10	4	GF162311.9512	●	GF162316.9512	●
1	16	11.9	90	25.4	45	12	4	GF162321.9512	●	GF162326.9512	●
1	22	15.9	100	32.4	48	16	5	GF162331.9512	●	GF162336.9512	●
1	27	19.9	115	40.4	50	20	5	GF162351.9512	●	GF162356.9512	●
1.5	14	9.9	80	21.6	40	10	4	GF162311.9514	●	GF162316.9514	●
1.5	16	11.9	90	26.1	45	12	4	GF162321.9514	●	GF162326.9514	●
1.5	22	15.9	100	33.6	48	16	5	GF162331.9514	●	GF162336.9514	●
1.5	27	19.9	115	41.1	50	20	5	GF162351.9514	●	GF162356.9514	●
2	18	11.9	90	26.9	45	12	4	GF162321.9516	●	GF162326.9516	●
2	22	15.9	100	32.9	48	16	5	GF162331.9516	●	GF162336.9516	●
2	27	19.9	115	40.9	50	20	5	GF162351.9516	●	GF162356.9516	●
3	24	15.9	100	34.3	48	16	5	GF162331.9518	●	GF162336.9518	●
3	30	19.9	115	43.3	50	20	5	GF162351.9518	●	GF162356.9518	●

Tools for different thread pitch upon request

● = In stock
★ = Allow 7 days for delivery

- Product Finder
- v_c / f_z
- UNC
- UNF
- UN
- M
- MF
- NPSF
- Rp (BSPP)
- G
- W
- BSW, BSF
- NPT
- NPTF
- Rc (BSPT)
- STI
- SELF-LOCK
- Accessories
- Tech. Info
- BGF
- ZBGF
- GSF (Aero)
- GSF-Z
- GF(I), GF-Z
- GF-Vario-Z
- GF-H
- GF(I)-KEG
- ZGF(I)
- CIRC-GF
- Gigant
- FPC, FMC
- MoSys



- Product Finder
- v_c / f_z
- UNC
- UNF
- UN
- M
- MF
- NPSF
- Rp (BSPP)
- G
- W
- BSW, BSF
- NPT
- NPTF
- Rc (BSPT)
- STI
- SELF-LOCK
- Accessories
- Tech. Info
- BGF
- ZBGF
- GSF (Aero)
- GSF-Z
- GF (I), GF-Z
- GF-Vario-Z
- GF-H
- GF(I)-KEG
- ZGF(I)
- CIRC-GF
- Gigant
- FPC, FMC
- MoSys

Metric Shank

Carbide

RH + LH

4-5 Flutes



DIN 6535



$\varnothing D$



new



new



For external threads

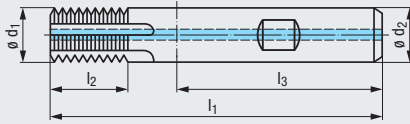

Coating

TICN

Applications – Material

P	1.1-5.1	K	1.1-4.2	P	1.1-5.1	M	1.1-4.1
N	1.1-5, 2.1-6	N	3.1-2	K	1.1-4.2	N	1.1-5.2
N	4.1-2, 5.2	S	1.1-3	S	1.1-2.6	H	1.1-2

M, MF

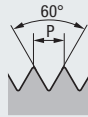

ISO Metric Threads
DIN 13

P mm	$\varnothing D_{min.}$	$\varnothing d_1$	l_1	mm		$\varnothing d_2$	Flutes	GF-VHM Ext.-IKZ-HB		GF-VHM Ext.-IKZ-HB TICN	
				l_2	l_3						
1	10	9.9	70	16.5	40	10	4	GF161211.9512	●	GF161216.9512	●
1	12	11.9	80	20.5	45	12	4	GF161121.9512	●	GF161126.9512	●
1.5	12	11.9	80	21.75	45	12	4	GF161121.9514	●	GF161126.9514	●
1.5	16	15.9	90	26.25	48	16	5	GF161131.9514	●	GF161136.9514	●
1.5	20	19.9	105	33.75	50	20	5	GF161151.9514	●	GF161156.9514	●
2	16	15.9	90	27	48	16	5	GF161131.9516	●	GF161136.9516	●
2	20	19.9	105	33	50	20	5	GF161151.9516	●	GF161156.9516	●
3	20	19.9	105	34.5	50	20	5	GF161151.9518	●	GF161156.9518	●

Tools for different thread pitch upon request

With right-hand spiral flutes upon request

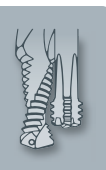

Metric Shank

Carbide

R15

RH + LH

6 Flutes



DIN 6535



ø D



For internal threads

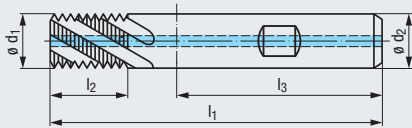

With increased number of flutes



Coating

TICN

Applications – Material

P	1.1-5.1	K	1.1-4.2	P	1.1-5.1	M	1.1-4.1
N	1.1-5, 2.1-6	N	3.1-2	K	1.1-4.2	N	1.1-5.2
N	4.1-2, 5.2	S	1.1-3	S	1.1-2.6	H	1.1-2

M, MF

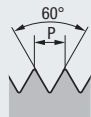

ISO Metric Threads
DIN 13

P mm	ø D _{min.}	ø d ₁	l ₁	mm l ₂	l ₃	ø d ₂	Flutes	GF-Z-VHM R15- IKZ-HB	GF-Z-VHM R15- IKZ-HB TICN
1	14	9.9	70	20.4	40	10	6	GF165361.9512 ●	GF165366.9512 ●
1.5	16	11.9	80	26.1	45	12	6	GF165371.9514 ●	GF165376.9514 ●
2	22	15.9	90	32.9	48	16	6	GF165381.9516 ●	GF165386.9516 ●
3	30	19.9	105	43.3	50	20	6	GF165391.9518 ●	GF165396.9518 ●

Tools for different thread pitch upon request

- Product Finder
- v_c / f_z
- UNC
- UNF
- UN
- M
- MF
- NPSF
- Rp (BSPP)
- G
- W
- BSW, BSF
- NPT
- NPTF
- Rc (BSPT)
- STI
- SELF-LOCK
- Accessories
- Tech. Info
- BGF
- ZBGF
- GSF (Aero)
- GSF-Z
- GF(I), GF-Z
- GF-Vario-Z
- GF-H
- GF(I)-KEG
- ZGF(I)
- CIRC-GF
- Gigant
- FPC, FMC
- MoSys

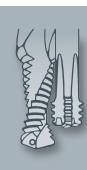

- Product Finder
- v_c / f_z
- UNC
- UNF
- UN
- M
- MF
- NPSF
- Rp (BSPP)
- G
- W
- BSW, BSF
- NPT
- NPTF
- Rc (BSPT)
- STI
- SELF-LOCK
- Accessories
- Tech. Info
- BGF
- ZBGF
- GSF (Aero)
- GSF-Z
- GF(I), GF-Z
- GF-Vario-Z
- GF-H
- GF(I)-KEG
- ZGF(I)
- CIRC-GF
- Gigant
- FPC, FMC
- MoSys

Metric Shank

Carbide

R15

RH + LH

4-6 Flutes



DIN 6535



$\varnothing D$



With increased number of flutes



For internal threads

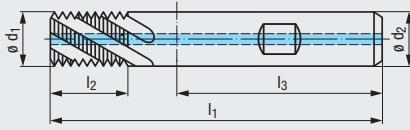

Coating

TICN

Applications – Material

P	1.1-5.1	K	1.1-4.2	P	1.1-5.1	M	1.1-4.1
N	1.1-5, 2.1-6	N	3.1-2	K	1.1-4.2	N	1.1-5.2
N	4.1-2, 5.2	S	1.1-3	S	1.1-2.6	H	1.1-2

M, MF



ISO Metric Threads
DIN 13

P mm	$\varnothing D$	$\varnothing d_1$	l_1	mm		$\varnothing d_2$	Flutes	GF-VZ-VHM R15-IKZ-HB		GF-VZ-VHM R15-IKZ-HB TICN	
				l_2	l_3						
0.5	≥ M 3	2.4	51	6.2	36	6	4	GFB35101.0030	●	GFB35106.0030	●
0.7	≥ M 4	3.15	55	8.7	36	6	4	GFB35101.0040	●	GFB35106.0040	●
0.8	≥ M 5	4	55	10.8	36	6	4	GFB35101.0050	●	GFB35106.0050	●
1	≥ M 6	4.8	55	12.4	36	6	4	GFB35101.0060	●	GFB35106.0060	●
1.25	≥ M 8	6.5	63	16.8	36	8	4	GFB35101.0080	●	GFB35106.0080	●
1.5	≥ M10	8.2	70	21.7	40	10	5	GFB35101.0100	●	GFB35106.0100	●
1.75	≥ M12	9.9	74	25.3	40	10	5	GFB35101.0112	●	GFB35106.0112	●
2	≥ M14	11.6	85	28.9	45	12	5	GFB35101.0114	●	GFB35106.0114	●
2.5	≥ M18	15	100	38.6	48	16	5	GFB35101.0118	●	GFB35106.0118	●
3	≥ M24	19.9	115	49.4	50	20	6	GFB35101.0124	●	GFB35106.0124	●

Tools for different thread pitch upon request

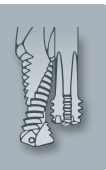

Metric Shank

Carbide

R15

RH + LH

4-5 Flutes



DIN 6535



For internal threads

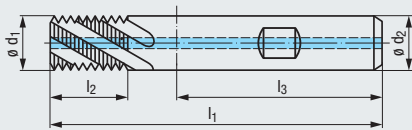

With increased number of flutes



Coating

TICN

Applications – Material

P	1.1-5.1	K	1.1-4.2	P	1.1-5.1	M	1.1-4.1
N	1.1-5, 2.1-6	N	3.1-2	K	1.1-4.2	N	1.1-5.2
N	4.1-2, 5.2	S	1.1-3	S	1.1-2.6	H	1.1-2

MF

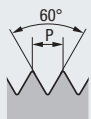

ISO Metric Fine Thread
DIN 13

P mm	$\varnothing D$	$\varnothing d_1$	l_1	mm l_2	l_3	$\varnothing d_2$	Flutes	GF-VZ-VHM R15-IKZ-HB	GF-VZ-VHM R15-IKZ-HB TICN
1	$\geq M 8$	6.7	63	16.4	36	8	4	GFB35101.0251 ●	GFB35106.0251 ●
1	$\geq M10$	8.7	70	20.4	40	10	5	GFB35101.0276 ●	GFB35106.0276 ●
1.5	$\geq M16$	14.1	95	33.7	48	16	5	GFB35101.0359 ●	GFB35106.0359 ●

Tools for different thread pitch upon request

Product
Finder

v_c / f_z

UNC

UNF

UN

M

MF

NPSF

Rp (BSPP)

G

W

BSW, BSF

NPT

NPTF

Rc (BSPT)

STI

SELF-LOCK

Accessories

Tech. Info

BGF

ZBGF

GSF (Aero)

GSF-Z

GF(I), GF-Z

GF-Vario-Z

GF-H

GF(I)-KEG

ZGF(I)

CIRC-GF

Gigant

FPC, FMC

MoSys



- Product Finder
- v_c / f_z
- UNC
- UNF
- UN
- M**
- MF
- NPSF
- Rp (BSPP)
- G
- W
- BSW, BSF
- NPT
- NPTF
- Rc (BSPT)
- STI
- SELF-LOCK
- Accessories
- Tech. Info
- BGF
- ZBGF
- GSF (Aero)
- GSF-Z
- GF(I), GF-Z
- GF-Vario-Z
- GF-H**
- GF(I)-KEG
- ZGF(I)
- CIRC-GF
- Gigant
- FPC, FMC
- MoSys

Metric Shank

Carbide

For hard materials

R10

RH + LH

4-5 Flutes



DIN 6535



ϕD



For internal threads

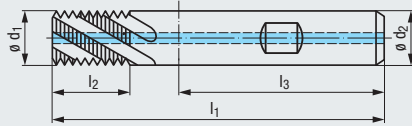

Coating

TICN

Applications – Material

N 2.7-8 H 1.3-5

M

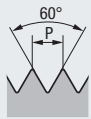

ISO Metric Coarse Thread
DIN 13

Nominal Size	ϕD	P mm	ϕd_1	l_1	mm		ϕd_2	Flutes	GF-H-VHM R10-IKZ-HB TICN
					l_2	l_3			
M 6	6	1	4.6	55	9.4	36	6	4	GF927126.0060
M 8	8	1.25	6.25	63	13.1	36	8	5	GF927126.0080
M 10	10	1.5	7.9	63	15.7	36	8	5	GF927126.0100
M 12	12	1.75	9.55	70	18.3	40	10	5	GF927126.0112
M 16	16	2	13.2	90	24.9	45	14	5	GF927126.0116
M 20	20	2.5	15.9	100	33.6	48	16	5	GF927126.0120

Tools for different thread pitch upon request

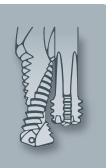

Metric Shank

Carbide

RH + LH

4-5 Flutes



DIN 6535



For internal and external threads

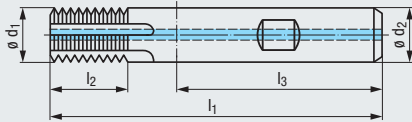

Coating

TICN

Applications – Material

P	1.1-5.1	K	1.1-4.2	P	1.1-5.1	M	1.1-4.1
N	1.1-5, 2.1-6	N	3.1-2	K	1.1-4.2	N	1.1-5.2
N	4.1-2, 5.2	S	1.1-3	S	1.1-2.6	H	1.1-2

G (BSP), Rp (BSPP), W



Whitworth Pipe Threads

DIN EN ISO 228, DIN EN 10226-1, ISO 7/1, BS 84

T.P.I.	ø D _{min.} ¹⁾	ø d ₁	inch			inch	ø d ₂	mm	Flutes	GF-VHM IKZ-HB		GF-VHM IKZ-HB TICN	
			l ₁	l ₂	l ₃					●	●	●	●
19	1/4	0.390	2.756	0.657	1.575	0.394	10	4	GF163211.9545	●	GF163216.9545	●	
14	1/2	0.626	3.543	1.035	1.890	0.630	16	5	GF163131.9548	●	GF163136.9548	●	
14	3/4	0.783	4.134	1.319	1.969	0.787	20	5	GF163151.9548	●	GF163156.9548	●	
11	1	0.626	3.543	1.043	1.890	0.630	16	5	GF163131.9550	●	GF163136.9550	●	
11	1	0.783	4.134	1.319	1.969	0.787	20	5	GF163151.9550	●	GF163156.9550	●	

¹⁾ Diameter related to internal pipe thread resp. external pipe thread

Product
Finder

v_c / f_z

UNC

UNF

UN

M

MF

NPSF

Rp (BSPP)

G

W

BSW, BSF

NPT

NPTF

Rc (BSPT)

STI

SELF-LOCK

Accessories

Tech. Info

BGF

ZBGF

GSF (Aero)

GSF-Z

GF(I), GF-Z

GF-Vario-Z

GF-H

GF(I)-KEG

ZGF(I)

CIRC-GF

Gigant

FPC, FMC

MoSys



- Product Finder
- v_c / f_z
- UNC
- UNF
- UN
- M
- MF
- NPSF
- Rp (BSPP)
- G
- W
- BSW, BSF
- NPT
- NPTF
- Rc (BSPT)
- STI
- SELF-LOCK
- Accessories
- Tech. Info
- BGF
- ZBGF
- GSF (Aero)
- GSF-Z
- GF(I), GF-Z
- GF-Vario-Z
- GF-H
- GF(I)-KEG
- ZGF(I)
- CIRC-GF
- Gigant
- FPC, FMC
- MoSys

Metric Shank

Carbide

R30

RH + LH

4-5 Flutes

DIN 6535



$\varnothing D$

$\varnothing D$



For internal and external threads

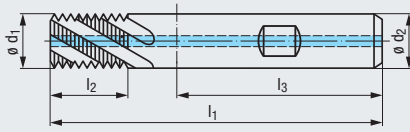

Coating

TICN

Applications – Material

P	1.1-3.1	K	1.1-4.2	P	1.1-3.1	M	1.1-2.1
N	1.1-5	N	2.1-6	K	1.1-4.2	N	1.1-2.7
N	3.1-4.2, 5.2	S	1.1-2	N	3.1-5.2	S	1.1-2, 2.1

G (BSP), Rp (BSPP), W

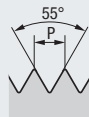

Whitworth Pipe Threads
DIN EN ISO 228, DIN EN 10226-1, ISO 7/1, BS 84

T.P.I.	$\varnothing D_{min.}^{1)}$	$\varnothing d_1$	inch			$\varnothing d_2$	mm	Flutes	GF-VHM R30-1KZ-HB		GF-VHM R30-1KZ-HB TICN	
			l_1	l_2	l_3							
19	1/4	0.390	2.756	0.657	1.575	0.394	10	4	GF162211.9545	●	GF162216.9545	●
14	1/2	0.469	3.150	0.823	1.772	0.472	12	4	GF162121.9548	●	GF162126.9548	●
14	1/2	0.626	3.543	1.035	1.890	0.630	16	5	GF162131.9548	●	GF162136.9548	●
14	3/4	0.783	4.134	1.319	1.969	0.787	20	5	GF162151.9548	●	GF162156.9548	●
11	1	0.626	3.543	1.043	1.890	0.630	16	5	GF162131.9550	●	GF162136.9550	●
11	1	0.783	4.134	1.319	1.969	0.787	20	5	GF162151.9550	●	GF162156.9550	●

1) Diameter related to internal pipe thread resp. external pipe thread

Metric Shank

Carbide

R15

RH + LH

5-8 Flutes



DIN 6535



For internal and external threads

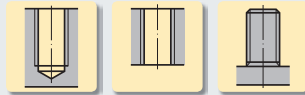
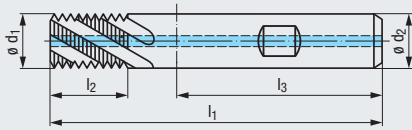

With increased number of flutes



new

new

Coating

TICN

Applications – Material

P	1.1-5.1	K	1.1-4.2	P	1.1-5.1	M	1.1-4.1
N	1.1-5, 2.1-6	N	3.1-2	K	1.1-4.2	N	1.1-5.2
N	4.1-2, 5.2	S	1.1-3	S	1.1-2.6	H	1.1-2

G (BSP), Rp (BSPP), W



Whitworth Pipe Threads

DIN EN ISO 228, DIN EN 10226-1, ISO 7/1, BS 84

T.P.I.	$\varnothing D_{min.}^{1)}$	$\varnothing d_1$	inch			$\varnothing d_2$		Flutes	GF-Z-VHM R15- IKZ -HB		GF-Z-VHM R15- IKZ -HB TICN	
			l_1	l_2	l_3	inch	mm					
19	1/4	0.390	2.756	0.815	1.575	0.394	10	6	GF165361.9545	●	GF165366.9545	●
14	1/2	0.469	3.150	1.035	1.772	0.472	12	5	GF165371.9548	●	GF165376.9548	●
14	1/2	0.626	3.543	1.323	1.890	0.630	16	6	GF165381.9548	●	GF165386.9548	●
14	3/4	0.783	4.134	1.606	1.969	0.787	20	8	GF165391.9548	★	GF165396.9548	★
11	1	0.626	3.543	1.319	1.890	0.630	16	5	GF165381.9550	●	GF165386.9550	●
11	1	0.783	4.134	1.681	1.969	0.787	20	6	GF165391.9550	●	GF165396.9550	●

Tools for different thread pitch upon request

● = In stock
★ = Allow 7 days for delivery

- Product Finder
- v_c / f_z
- UNC
- UNF
- UN
- M
- MF
- NPSF
- Rp (BSPP)
- G
- W
- BSW, BSF
- NPT
- NPTF
- Rc (BSPT)
- STI
- SELF-LOCK
- Accessories
- Tech. Info
- BGF
- ZBGF
- GSF (Aero)
- GSF-Z
- GF(I), GF-Z
- GF-Vario-Z
- GF-H
- GF(I)-KEG
- ZGF(I)
- CIRC-GF
- Gigant
- FPC, FMC
- MoSys

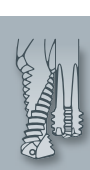

- Product Finder
- v_c / f_z
- UNC
- UNF
- UN
- M
- MF
- NPSF**
- Rp (BSPP)
- G
- W
- BSW, BSF
- NPT
- NPTF
- Rc (BSPT)
- STI
- SELF-LOCK
- Accessories
- Tech. Info
- BGF
- ZBGF
- GSF (Aero)
- GSF-Z
- GF(I), GF-Z
- GF-Vario-Z
- GF-H
- GF(I)-KEG
- ZGF(I)
- CIRC-GF
- Gigant
- FPC, FMC
- MoSys

Metric Shank

Carbide

R30

RH + LH

3-5 Flutes

DIN 6535



ϕD



For internal threads

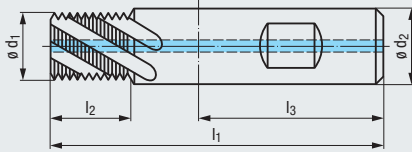

Coating

TICN

Applications – Material

P	1.1-3.1	K	1.1-4.2	P	1.1-3.1	M	1.1-2.1
N	1.1-5	N	2.1-6	K	1.1-4.2	N	1.1-2.7
N	3.1-4.2, 5.2	S	1.1-2	N	3.1-5.2	S	1.1-2, 2.1

NPSF



**American Standard Straight Pipe Thread
ANSI B1.20.3**

Dryseal internal straight pipe thread for fuel, combined with external tapered pipe thread NPTF or PTF-SAE-SHORT; Gage with tapered gages

Nominal Size ϕD	T.P.I.	ϕd_1	inch			ϕd_2	Flutes	GF-VHM R30-1KZ-HB		GF-VHM R30-1KZ-HB TICN	
			l_1	l_2	l_3			inch	mm		
1/16	27	0.232	2.480	0.424	1.417	0.315	8	3	GF172101.5904		GF172106.5904
1/8	27	0.301	2.480	0.424	1.417	0.315	8	3	GF172101.5905	●	GF172106.5905
1/4	18	0.400	3.150	0.637	1.772	0.472	12	4	GF172111.5906	●	GF172116.5906
3/8	18	0.439	3.150	0.636	1.772	0.472	12	4	GF172111.5907	●	GF172116.5907
1/2	14	0.561	3.543	0.819	1.890	0.630	16	4	GF172131.5908	●	GF172136.5908
3/4	14	0.561	3.543	0.819	1.890	0.630	16	4	GF172131.5909		GF172136.5909
1	11 1/2	0.772	4.134	1.000	1.969	0.787	20	5	GF172151.5910		GF172156.5910

NPSF cutters are manufactured with a corrected profile

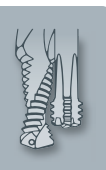

Metric Shank

Carbide

RH + LH

4-5 Flutes



DIN 6535



For internal threads

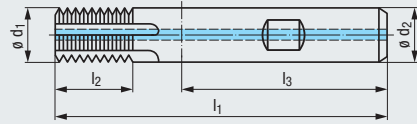

Coating

TiCN

Applications – Material

P	1.1-5.1	K	1.1-4.2	P	1.1-5.1	M	1.1-4.1
N	1.1-5, 2.1-6	N	3.1-2	K	1.1-4.2	N	1.1-5.2
N	4.1-2, 5.2	S	1.1-3	S	1.1-2.6	H	1.1-2

LK-M

LK-MF

Metric SELF-LOCK Thread
EMUGE Standard

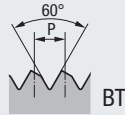

P mm	$\phi D_{min.}$	ϕd_1	l_1	mm l_2	l_3	ϕd_2	Flutes	GF-VHM IKZ-HB	GF-VHM IKZ-HB TiCN
1	14	9.9	70	16.4	40	10	4	GF163211.9757	GF163216.9757
1	16	11.9	80	20.4	45	12	4	GF163121.9757	GF163126.9757
1.5	14	9.9	70	17	40	10	4	GF163211.9664	GF163216.9664
1.5	16	11.9	80	21.5	45	12	4	GF163121.9664	GF163126.9664
2	22	15.9	90	26.7	48	16	5	GF163131.9705	GF163136.9705
3	30	19.9	105	34.1	50	20	5	GF163151.9767	GF163156.9767

Tools for different thread pitch upon request

Product
Finder

v_c / f_z

UNC

UNF

UN

M

MF

NPSF

Rp (BSPP)

G

W

BSW, BSF

NPT

NPTF

Rc (BSPT)

STI

SELF-LOCK

Accessories

Tech. Info

BGF

ZBGF

GSF (Aero)

GSF-Z

GF(I), GF-Z

GF-Vario-Z

GF-H

GF(I)-KEG

ZGF(I)

CIRC-GF

Gigant

FPC, FMC

MoSys

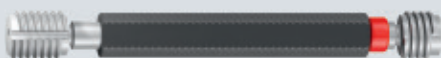

Gages for Metric SELF-LOCK Coarse Thread, see page 457

- Product Finder
- v_c / f_z
- UNC
- UNF
- UN
- M
- MF
- NPSF
- Rp (BSPP)
- G
- W
- BSW, BSF
- NPT
- NPTF
- Rc (BSPT)
- STI
- SELF-LOCK
- Accessories
- Tech. Info

- BGF
- ZBGF
- GSF (Aero)
- GSF-Z
- GF(I), GF-Z**
- GF-Vario-Z
- GF-H
- GF(I)-KEG
- ZGF(I)
- CIRC-GF
- Gigant
- FPC, FMC
- MoSys

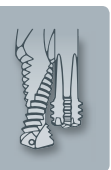

Straight Flutes GFI-KEG GFI-KEG-ECO	Left-Hand Spiral Flutes GFI-KEG	Straight Flutes GF-KEG	Straight Flutes GF-KEG	Right-Hand Spiral Flutes, Long Design GF-KEG	Right-Hand Spiral Flutes, Long Design GF-KEG
Inch Shank	Inch Shank	Metric Shank	Metric Shank	Metric Shank	Metric Shank
Page					
286, 287	292	288	289	290	291
		293	294	295	296
		297	298		
					NPT (API-LP)
					NPTF
					RC (BSPT)

Product Finder

v_c / f_z

UNC

UNF

UN

M

MF

NPSF

Rp (BSPP)

G

W

BSW, BSF

NPT

NPTF

Rc (BSPT)

STI

SELF-LOCK

Accessories

Tech. Info

BGF

ZBGF

GSF (Aero)

GSF-Z

GF(I), GF-Z

GF-Vario-Z

GF-H

GF(I)-KEG

ZGF(I)

CIRC-GF

Gigant

FPC, FMC

MoSys

Possible modifications



Face chamfer with/without cutting face



AZR/AZ (alternating teeth)



Remove incomplete thread



IKZN (internal coolant supply exiting in the flutes)



Recessed neck



Coolant grooves along the shank

For a description of these modifications, see page 357

Thread milling cycle

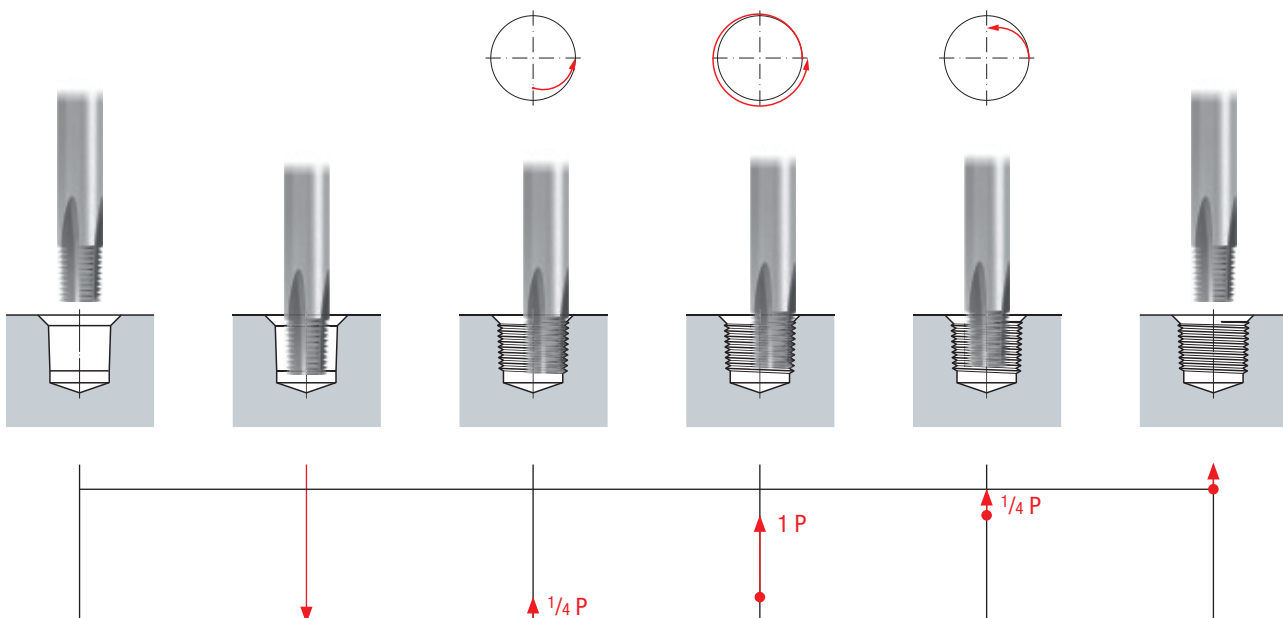

- Product Finder
- v_c / f_z
- UNC
- UNF
- UN
- M
- MF
- NPSF
- Rp (BSPP)
- G
- W
- BSW, BSF
- NPT**
- NPTF
- Rc (BSPT)
- STI
- SELF-LOCK
- Accessories
- Tech. Info
- BGF
- ZBGF
- GSF (Aero)
- GSF-Z
- GF(I), GF-Z
- GF-Vario-Z
- GF-H
- GFI-KEG**
- ZGF(I)
- CIRC-GF
- Gigant
- FPC, FMC
- MoSys

Inch Shank

For internal tapered threads

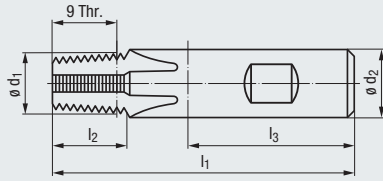

Carbide

RH + LH

3-5 Flutes



ASME B94.19



ø D



Without internal coolant supply (IKZ)



NPT



American Tapered Pipe Thread, ANSI/ASME B1.20.1

For threads with dryseal material, taper 1:16

Coating

TICN

Applications – Material

- P 1.1-5.1
- M 1.1-4.1
- K 1.1-4.2
- N 1.1-5.2
- S 1.1-2.6
- H 1.1-2

Nominal Size ø D	T.P.I.	l_1	l_2	inch l_3	$\varnothing d_1$	$\varnothing d_2$	Flutes	GFI-KEG-VHM HB TICN
1/16	27	2 1/4	0.388	1 3/8	0.232	5/16	3	GFT53106.5763
1/8	27	2 1/4	0.388	1 3/8	0.301	5/16	3	GFT53106.5764
1/4	18	3 1/4	0.582	1 25/32	0.400	1/2	4	GFT53116.5765
3/8	18	3 1/4	0.582	1 25/32	0.439	1/2	4	GFT53116.5766
1/2	14	3 1/2	0.749	1 29/32	0.561	5/8	4	GFT53136.9678
3/4	14							
1	11 1/2	3 3/4	0.913	2 1/32	0.772	3/4	5	GFT53156.9679
1 1/4	11 1/2							
1 1/2	11 1/2							
2	11 1/2							

NPT cutters are manufactured with a corrected profile

Application recommendation: You must have an NC program for a spiral formed helix to prevent a profile step

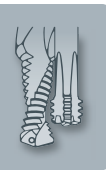

Inch Shank

The ECO design is perfect for short run manufacturers looking for economical tooling solution without sacrificing quality

For internal tapered threads

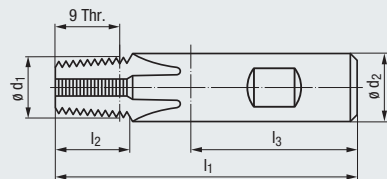

Carbide

RH + LH

3-4 Flutes



ASME B94.19



Coating

TICN

Applications – Material

- P 1.1-5.1 M 1.1-4.1
- K 1.1-4.2 N 1.1-5.2
- S 1.1-2.6 H 1.1-2

Without internal coolant supply (IKZ)



NPT

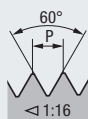

American Tapered Pipe Thread, ANSI/ASME B1.20.1

For threads with dryseal material, taper 1:16

Nominal Size ø D	T.P.I.	l ₁	l ₂	inch l ₃	ø d ₁	ø d ₂	Flutes	GFI-ECO-KEG-VHM HB TICN
1/16	27	2 1/2	0.388	1 3/8	0.232	1/4	3	GFT53AA6.5763
1/8	27	2 1/2	0.388	1 3/8	0.246	1/4	3	GFT53AA6.5764
1/4	18	2 1/2	0.582	1 3/8	0.307	5/16	3	GFT53A06.9677
3/8	18							
1/2	14	3 1/2	0.748	1 25/32	0.488	1/2	4	GFT53A16.9678
3/4	14							
1	11 1/2	4	0.911	1 29/32	0.606	5/8	4	GFT53A36.9679
1 1/4	11 1/2							
1 1/2	11 1/2							
2	11 1/2							

NPT cutters are manufactured with a corrected profile

Application recommendation: You must have an NC program for a spiral formed helix to prevent a profile step

Thread Hole Preparatory Diameters for Tapered Pipe Thread NPT, Taper 1:16

A) Cylindrical preparation of thread hole

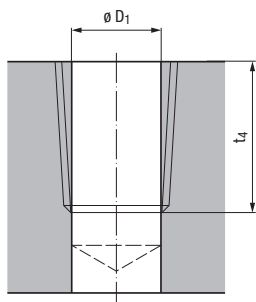

B) Tapered preparation of thread hole

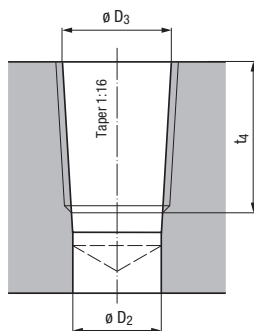

Nominal size ø D	T.P.I.	ø D ₁	ø D ₂	inch ø D ₃ (+0.002)	t ₄
1/16	27	0.2421	0.2343	0.2516	0.3268
1/8	27	0.3346	0.3268	0.3441	0.3268
1/4	18	0.4331	0.4232	0.4472	0.4783
3/8	18	0.5669	0.5571	0.5827	0.4902
1/2	14	0.7008	0.6870	0.7213	0.6417
3/4	14	0.9114	0.8976	0.9319	0.6417
1	11 1/2	1.1437	1.1280	1.1689	0.7697
1 1/4	11 1/2	1.4882	1.4705	1.5138	0.7894
1 1/2	11 1/2	1.7264	1.7106	1.7528	0.7894
2	11 1/2	2.1988	2.1831	2.2268	0.8051

● = In stock
★ = Allow 7 days for delivery

- Product Finder
- v_c / f_z
- UNC
- UNF
- UN
- M
- MF
- NPSF
- Rp (BSPP)
- G
- W
- BSW, BSF
- NPT**
- NPTF
- Rc (BSPT)
- STI
- SELF-LOCK
- Accessories
- Tech. Info
- BGF
- ZBGF
- GSF (Aero)
- GSF-Z
- GF(I), GF-Z
- GF-Vario-Z
- GF-H
- GFI-KEG**
- ZGF(I)
- CIRC-GF
- Gigant
- FPC, FMC
- MoSys

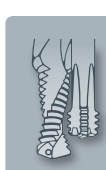

- Product Finder
- v_c / f_z
- UNC
- UNF
- UN
- M
- MF
- NPSF
- Rp (BSPP)
- G
- W
- BSW, BSF
- NPT**
- NPTF
- Rc (BSPT)
- STI
- SELF-LOCK
- Accessories
- Tech. Info
- BGF
- ZBGF
- GSF (Aero)
- GSF-Z
- GF(I), GF-Z
- GF-Vario-Z
- GF-H
- GF-KEG**
- ZGF(I)
- CIRC-GF
- Gigant
- FPC, FMC
- MoSys

Metric Shank

Carbide

RH + LH

3-5 Flutes



DIN 6535



For internal tapered threads

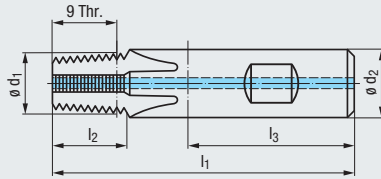

Coating

TICN

Applications – Material

P	1.1-5.1	K	1.1-4.2	P	1.1-5.1	M	1.1-4.1
N	1.1-5, 2.1-6	N	3.1-2	K	1.1-4.2	N	1.1-5.2
N	4.1-2, 5.2	S	1.1-3	S	1.1-2.6	H	1.1-2

NPT



American Tapered Pipe Thread, ANSI/ASME B1.20.1

For threads with dryseal material, taper 1:16

Nominal Size	ϕD	T.P.I.	inch			ϕd_1	inch	ϕd_2	mm	Flutes	GF-KEG-VHM IKZ-HB		GF-KEG-VHM IKZ-HB TICN	
			l_1	l_2	l_3						●	●	●	●
1/16		27	2.165	0.388	1.417	0.232	0.315	8	3	GF173101.5763	●	GF173106.5763	●	
1/8		27	2.165	0.388	1.417	0.301	0.315	8	3	GF173101.5764	●	GF173106.5764	●	
1/4		18	2.953	0.582	1.772	0.400	0.472	12	4	GF173111.5765	●	GF173116.5765	●	
3/8		18	2.953	0.582	1.772	0.439	0.472	12	4	GF173111.5766	●	GF173116.5766	●	
1/2		14	3.150	0.749	1.890	0.561	0.630	16	4	GF173131.9678	●	GF173136.9678	●	
3/4		14												
1		11 1/2	3.543	0.911	1.969	0.772	0.787	20	5	GF173151.9679	●	GF173156.9679	●	
1 1/4		11 1/2												
1 1/2		11 1/2												
2		11 1/2												

NPT cutters are manufactured with a corrected profile

Application recommendation: You must have an NC program for a spiral formed helix to prevent a profile step

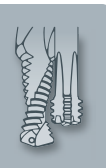

Metric Shank

Carbide

RH + LH

3-5 Flutes



DIN 6535



For internal tapered threads

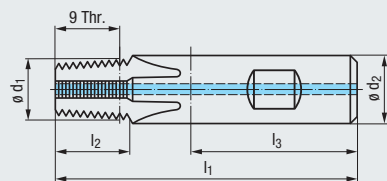

new



new



NPT
American Tapered Pipe Thread,
ANSI/ASME B1.20.1

For threads with dryseal material,
taper 1:16

Coating

Applications – Material

P 1.1-5.1	K 1.1-4.2	P 1.1-5.1	M 1.1-4.1
N 1.1-5, 2.1-6	N 3.1-2	K 1.1-4.2	N 1.1-5.2
N 4.1-2, 5.2	S 1.1-3	S 1.1-2.6	H 1.1-2

TICN

Nominal Size	T.P.I.	l_1	l_2	l_3	$\varnothing d_1$	$\varnothing d_2$	Flutes
$\varnothing D$		inch	inch	inch	inch	mm	
1/16	27	2.165	0.388	1.417	0.232	0.315	3
1/8	27	2.165	0.388	1.417	0.301	0.315	3
1/4	18	2.953	0.582	1.772	0.400	0.472	4
3/8	18	2.953	0.582	1.772	0.439	0.472	4
1/2	14	3.150	0.749	1.890	0.561	0.630	4
3/4	14						
1	11 1/2	3.543	0.911	1.969	0.772	0.787	5
1 1/4	11 1/2						
1 1/2	11 1/2						
2	11 1/2						

GF-KEG-VHM
IKZN-HB

GF-KEG-VHM
IKZN-HB
TICN

GF193101.5763	●	GF193106.5763	●
GF193101.5764	●	GF193106.5764	●
GF193111.5765	●	GF193116.5765	●
GF193111.5766	●	GF193116.5766	●
GF193131.9678	●	GF193136.9678	●
GF193151.9679	●	GF193156.9679	●

NPT cutters are manufactured with a corrected profile

Application recommendation: You must have an NC program for a spiral formed helix to prevent a profile step

Thread Hole Preparatory Diameters for Tapered Pipe Thread NPT, Taper 1:16

A) Cylindrical preparation of thread hole

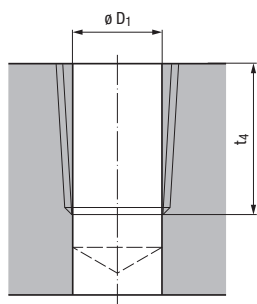

B) Tapered preparation of thread hole

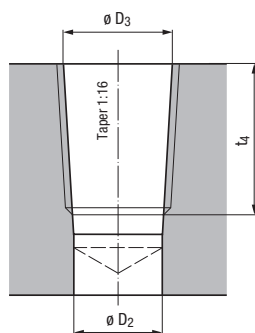

Nominal size	T.P.I.	$\varnothing D_1$	$\varnothing D_2$	$\varnothing D_3$	t_4
$\varnothing D$		inch	inch	inch (+0.002)	
1/16	27	0.2421	0.2343	0.2516	0.3268
1/8	27	0.3346	0.3268	0.3441	0.3268
1/4	18	0.4331	0.4232	0.4472	0.4783
3/8	18	0.5669	0.5571	0.5827	0.4902
1/2	14	0.7008	0.6870	0.7213	0.6417
3/4	14	0.9114	0.8976	0.9319	0.6417
1	11 1/2	1.1437	1.1280	1.1689	0.7697
1 1/4	11 1/2	1.4882	1.4705	1.5138	0.7894
1 1/2	11 1/2	1.7264	1.7106	1.7528	0.7894
2	11 1/2	2.1988	2.1831	2.2268	0.8051

- Product Finder
- v_c / f_z
- UNC
- UNF
- UN
- M
- MF
- NPSF
- Rp (BSPP)
- G
- W
- BSW, BSF
- NPT
- NPTF
- Rc (BSPT)
- STI
- SELF-LOCK
- Accessories
- Tech. Info
- BGF
- ZBGF
- GSF (Aero)
- GSF-Z
- GF(I), GF-Z
- GF-Vario-Z
- GF-H
- GF-KEG
- ZGF(I)
- CIRC-GF
- Gigant
- FPC, FMC
- MoSys



- Product Finder
- v_c / f_z
- UNC
- UNF
- UN
- M
- MF
- NPSF
- Rp (BSPP)
- G
- W
- BSW, BSF
- NPT**
- NPTF
- Rc (BSPT)
- STI
- SELF-LOCK
- Accessories
- Tech. Info
- BGF
- ZBGF
- GSF (Aero)
- GSF-Z
- GF(I), GF-Z
- GF-Vario-Z
- GF-H
- GF-KEG**
- ZGF(I)
- CIRC-GF
- Gigant
- FPC, FMC
- MoSys

Metric Shank

Carbide

R15

RH + LH

3-5 Flutes



DIN 6535



For internal tapered threads

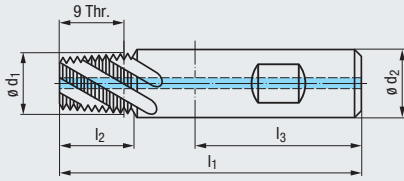

Coating

TICN

Applications – Material

P	1.1-5.1	K	1.1-4.2	P	1.1-5.1	M	1.1-4.1
N	1.1-5, 2.1-6	N	3.1-2	K	1.1-4.2	N	1.1-5.2
N	4.1-2, 5.2	S	1.1-3	S	1.1-2.6	H	1.1-2

NPT (API-LP)



American Tapered Pipe Thread,
ANSI/ASME B1.20.1

For threads with dryseal material,
taper 1:16

Nominal Size	T.P.I.	inch			$\varnothing d_1$	inch		mm	Flutes	GF-KEG-VHM R15-Ig-IKZ-HB		GF-KEG-VHM R15-Ig-IKZ-HB TICN	
		l_1	l_2	l_3		$\varnothing d_1$	$\varnothing d_2$						
1/16	27	2.362	0.537	1.417	0.232	0.315	8	3	GF175301.5763	●	GF175306.5763	●	
1/8	27	2.362	0.537	1.417	0.301	0.315	8	3	GF175301.5764	●	GF175306.5764	●	
1/4	18	3.150	0.805	1.772	0.400	0.472	12	4	GF175311.5765	●	GF175316.5765	●	
3/8	18	3.150	0.804	1.772	0.439	0.472	12	4	GF175311.5766	●	GF175316.5766	●	
1/2	14	3.346	1.034	1.890	0.561	0.630	16	4	GF175331.9678	●	GF175336.9678	●	
3/4	14												
1	11 1/2	3.740	1.259	1.969	0.772	0.787	20	5	GF175351.9679	●	GF175356.9679	●	
1 1/4	11 1/2												
1 1/2	11 1/2												
2	11 1/2												

NPT/API-LP cutters are manufactured with a corrected profile

Application recommendation: You must have an NC program for a spiral formed helix to prevent a profile step

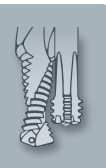

Metric Shank

Carbide

R15

RH + LH

3-5 Flutes



DIN 6535



For internal tapered threads

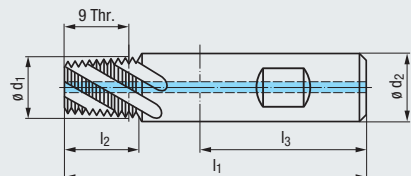

new



new



NPT (API-LP)

American Tapered Pipe Thread, ANSI/ASME B1.20.1

For threads with dryseal material, taper 1:16



Coating

Applications – Material

P 1.1-5.1	K 1.1-4.2	P 1.1-5.1	M 1.1-4.1
N 1.1-5, 2.1-6	N 3.1-2	K 1.1-4.2	N 1.1-5.2
N 4.1-2, 5.2	S 1.1-3	S 1.1-2.6	H 1.1-2

TICN

Nominal Size ϕD	T.P.I.	inch			ϕd_1	inch		ϕd_2	mm	Flutes
		l_1	l_2	l_3						
1/16	27	2.362	0.537	1.417	0.232	0.315	8	3		
1/8	27	2.362	0.537	1.417	0.301	0.315	8	3		
1/4	18	3.150	0.805	1.772	0.400	0.472	12	4		
3/8	18	3.150	0.804	1.772	0.439	0.472	12	4		
1/2	14	3.346	1.034	1.890	0.561	0.630	16	4		
3/4	14									
1	11 1/2	3.740	1.259	1.969	0.772	0.787	20	5		
1 1/4	11 1/2									
1 1/2	11 1/2									
2	11 1/2									

GF-KEG-VHM
R15-Ig-1KZN-HB

GF-KEG-VHM
R15-Ig-1KZN-HB
TICN

GF195301.5763	●	GF195306.5763	●
GF195301.5764	●	GF195306.5764	●
GF195311.5765	●	GF195316.5765	●
GF195311.5766	●	GF195316.5766	●
GF195331.9678	●	GF195336.9678	●
GF195351.9679	●	GF195356.9679	●

NPT/API-LP cutters are manufactured with a corrected profile

Application recommendation: You must have an NC program for a spiral formed helix to prevent a profile step

Thread Hole Preparatory Diameters for Tapered Pipe Thread NPT, Taper 1:16

A) Cylindrical preparation of thread hole

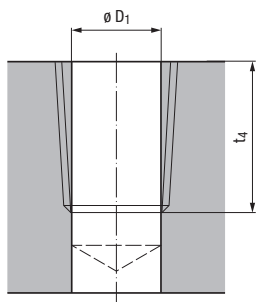

B) Tapered preparation of thread hole

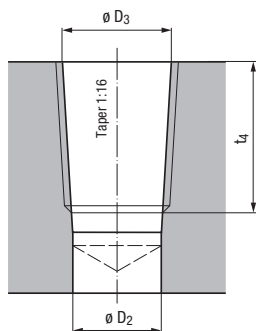

Nominal size ϕD	T.P.I.	inch			t_4
		ϕD_1	ϕD_2	ϕD_3 (+0.002)	
1/16	27	0.2421	0.2343	0.2516	0.3268
1/8	27	0.3346	0.3268	0.3441	0.3268
1/4	18	0.4331	0.4232	0.4472	0.4783
3/8	18	0.5669	0.5571	0.5827	0.4902
1/2	14	0.7008	0.6870	0.7213	0.6417
3/4	14	0.9114	0.8976	0.9319	0.6417
1	11 1/2	1.1437	1.1280	1.1689	0.7697
1 1/4	11 1/2	1.4882	1.4705	1.5138	0.7894
1 1/2	11 1/2	1.7264	1.7106	1.7528	0.7894
2	11 1/2	2.1988	2.1831	2.2268	0.8051

● = In stock
★ = Allow 7 days for delivery

- Product Finder
- v_c / f_z
- UNC
- UNF
- UN
- M
- MF
- NPSF
- Rp (BSPP)
- G
- W
- BSW, BSF
- NPT
- NPTF
- Rc (BSPT)
- STI
- SELF-LOCK
- Accessories
- Tech. Info
- BGF
- ZBGF
- GSF (Aero)
- GSF-Z
- GF(I), GF-Z
- GF-Vario-Z
- GF-H
- GF-KEG
- ZGF(I)
- CIRC-GF
- Gigant
- FPC, FMC
- MoSys



- Product Finder
- v_c / f_z
- UNC
- UNF
- UN
- M
- MF
- NPSF
- Rp (BSPP)
- G
- W
- BSW, BSF
- NPT**
- NPTF
- Rc (BSPT)
- STI
- SELF-LOCK
- Accessories
- Tech. Info
- BGF
- ZBGF
- GSF (Aero)
- GSF-Z
- GF(I), GF-Z
- GF-Vario-Z
- GF-H
- GFI-KEG**
- ZGF(I)
- CIRC-GF
- Gigant
- FPC, FMC
- MoSys

Inch Shank

Carbide

With coolant grooves along the shank

L15

RH + LH

4-5 Flutes

DIN 6535



new



For internal tapered threads

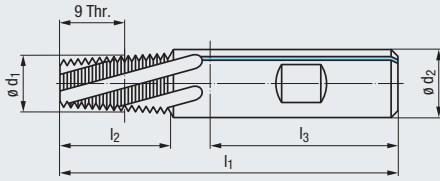

Coating

TIALN-T46

Applications – Material

- P 1.1-5.1
- M 1.1-4.1
- K 1.1-4.2
- N 1.1-5.2
- S 1.1-2.6
- H 1.1-2

NPT (API-LP)



American Tapered Pipe Thread, ANSI/ASME B1.20.1

For threads with dryseal material, taper 1:16

Nominal Size	T.P.I.	l_1	l_2	inch l_3	$\varnothing d_1$	$\varnothing d_2$	Flutes	GFI-KEG-VHM L15-SKN-HB TIALN-T46
$\varnothing D$								
1/16	27	2 1/4	0.536	1 3/8	0.232	5/16	4	GFT8B209.9676
1/8	27							
1/4	18	3 1/4	0.804	1 25/32	0.399	1/2	4	GFT8B219.9677
3/8	18							
1/2	14	3 1/2	1.034	1 29/32	0.561	5/8	4	GFT8B239.9678
3/4	14							
1	11 1/2	3 3/4	1.259	2 1/32	0.772	3/4	5	GFT8B259.9679
1 1/4	11 1/2							
1 1/2	11 1/2							
2	11 1/2							

NPT/API-LP cutters are manufactured with a corrected profile

Application recommendation: You must have an NC program for a spiral formed helix to prevent a profile step

Thread Hole Preparatory Diameters for Tapered Pipe Thread NPT, Taper 1:16

A) Cylindrical preparation of thread hole

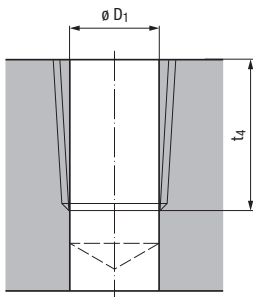

B) Tapered preparation of thread hole

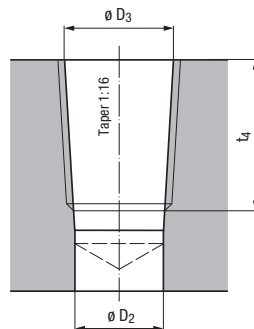

Nominal size $\varnothing D$	T.P.I.	$\varnothing D_1$	$\varnothing D_2$	inch $\varnothing D_3$ (+0.002)	t_4
1/16	27	0.2421	0.2343	0.2516	0.3268
1/8	27	0.3346	0.3268	0.3441	0.3268
1/4	18	0.4331	0.4232	0.4472	0.4783
3/8	18	0.5669	0.5571	0.5827	0.4902
1/2	14	0.7008	0.6870	0.7213	0.6417
3/4	14	0.9114	0.8976	0.9319	0.6417
1	11 1/2	1.1437	1.1280	1.1689	0.7697
1 1/4	11 1/2	1.4882	1.4705	1.5138	0.7894
1 1/2	11 1/2	1.7264	1.7106	1.7528	0.7894
2	11 1/2	2.1988	2.1831	2.2268	0.8051

Metric Shank

Carbide

RH + LH

3-5 Flutes



DIN 6535



For internal tapered threads

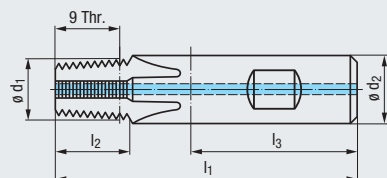

NPTF



American Tapered Pipe Thread,
ANSI/ASME B1.20.3

For threads without dryseal material,
taper 1:16

Coating

TICN

Applications – Material

P	1.1-5.1	K	1.1-4.2	P	1.1-5.1	M	1.1-4.1
N	1.1-5, 2.1-6	N	3.1-2	K	1.1-4.2	N	1.1-5.2
N	4.1-2, 5.2	S	1.1-3	S	1.1-2.6	H	1.1-2

Nominal Size ϕD	T.P.I.	inch			ϕd_1	inch		ϕd_2	mm	Flutes
		l_1	l_2	l_3						
1/16	27	2.165	0.387	1.417	0.232	0.315	8	3		
1/8	27	2.165	0.387	1.417	0.301	0.315	8	3		
1/4	18	2.953	0.581	1.772	0.400	0.472	12	4		
3/8	18	2.953	0.581	1.772	0.439	0.472	12	4		
1/2	14	3.150	0.748	1.890	0.561	0.630	16	4		
3/4	14	3.150	0.748	1.890	0.561	0.630	16	4		
1	11 1/2	3.543	0.911	1.969	0.772	0.787	20	5		
1 1/4	11 1/2									
1 1/2	11 1/2									
2	11 1/2									

GF-KEG-VHM
IKZ-HB

GF-KEG-VHM
IKZ-HB
TICN

GF173101.5782	●	GF173106.5782	●
GF173101.5783	●	GF173106.5783	●
GF173111.5784	●	GF173116.5784	●
GF173111.5785	●	GF173116.5785	●
GF173131.5786	●	GF173136.5786	●
GF173131.5787	●	GF173136.5787	●

GF173151.9684	●	GF173156.9684	●
---------------	---	---------------	---

NPTF cutters are manufactured with a corrected profile

Application recommendation: You must have an NC program for a spiral formed helix to prevent a profile step

Thread Hole Preparatory Diameters for Tapered Pipe Thread NPTF, Taper 1:16

A) Cylindrical preparation of thread hole

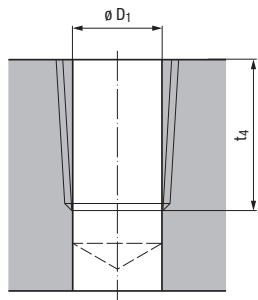

B) Tapered preparation of thread hole

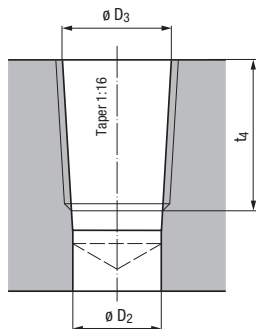

Nominal size ϕD	T.P.I.	inch			t_4
		ϕD_1	ϕD_2	ϕD_3 (+0.002)	
1/16	27	0.2402	0.2343	0.2524	0.3268
1/8	27	0.3327	0.3268	0.3449	0.3268
1/4	18	0.4291	0.4232	0.4488	0.4783
3/8	18	0.5630	0.5571	0.5843	0.4902
1/2	14	0.6929	0.6870	0.7217	0.6417
3/4	14	0.9055	0.8976	0.9323	0.6417
1	11 1/2	1.1319	1.1280	1.1701	0.7697
1 1/4	11 1/2	1.4764	1.4705	1.5150	0.7894
1 1/2	11 1/2	1.7224	1.7106	1.7539	0.7894
2	11 1/2	2.1949	2.1831	2.2280	0.8051

● = In stock
★ = Allow 7 days for delivery

Product Finder

v_c / f_z

UNC

UNF

UN

M

MF

NPSF

Rp (BSPP)

G

W

BSW, BSF

NPT

NPTF

Rc (BSPT)

STI

SELF-LOCK

Accessories

Tech. Info

BGF

ZBGF

GSF (Aero)

GSF-Z

GF(I), GF-Z

GF-Vario-Z

GF-H

GF-KEG

ZGF(I)

CIRC-GF

Gigant

FPC, FMC

MoSys



- Product Finder
- v_c / f_z
- UNC
- UNF
- UN
- M
- MF
- NPSF
- Rp (BSPP)
- G
- W
- BSW, BSF
- NPT
- NPTF
- Rc (BSPT)
- STI
- SELF-LOCK
- Accessories
- Tech. Info
- BGF
- ZBGF
- GSF (Aero)
- GSF-Z
- GF(I), GF-Z
- GF-Vario-Z
- GF-H
- GF-KEG**
- ZGF(I)
- CIRC-GF
- Gigant
- FPC, FMC
- MoSys

Metric Shank

Carbide

RH + LH

3-5 Flutes



DIN 6535



new



new



For internal tapered threads

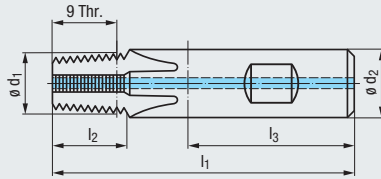

Coating

TICN

Applications – Material

P	1.1-5.1	K	1.1-4.2	P	1.1-5.1	M	1.1-4.1
N	1.1-5, 2.1-6	N	3.1-2	K	1.1-4.2	N	1.1-5.2
N	4.1-2, 5.2	S	1.1-3	S	1.1-2.6	H	1.1-2

NPTF



American Tapered Pipe Thread,
ANSI/ASME B1.20.3

For threads without dryseal material,
taper 1:16

Nominal Size	$\varnothing D$	T.P.I.	inch			$\varnothing d_1$	inch		Flutes	GF-KEG-VHM IKZN-HB		GF-KEG-VHM IKZN-HB TICN	
			l_1	l_2	l_3		$\varnothing d_2$	mm					
1/16		27	2.165	0.387	1.417	0.232	0.315	8	3	GF193101.5782	●	GF193106.5782	●
1/8		27	2.165	0.387	1.417	0.301	0.315	8	3	GF193101.5783	●	GF193106.5783	●
1/4		18	2.953	0.581	1.772	0.400	0.472	12	4	GF193111.5784	●	GF193116.5784	●
3/8		18	2.953	0.581	1.772	0.439	0.472	12	4	GF193111.5785	●	GF193116.5785	●
1/2		14	3.150	0.748	1.890	0.561	0.630	16	4	GF193131.5786	●	GF193136.5786	●
3/4		14	3.150	0.748	1.890	0.561	0.630	16	4	GF193131.5787	●	GF193136.5787	●
1	11 1/2	}	3.543	0.911	1.969	0.772	0.787	20	5	GF193151.9684	●	GF193156.9684	●
1 1/4	11 1/2												
1 1/2	11 1/2												
2	11 1/2												

NPTF cutters are manufactured with a corrected profile

Application recommendation: You must have an NC program for a spiral formed helix to prevent a profile step

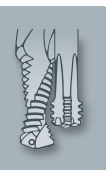

Metric Shank

Carbide

R15

RH + LH

3-5 Flutes

DIN 6535



For internal tapered threads

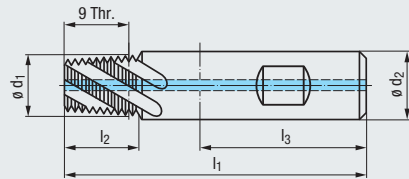

NPTF

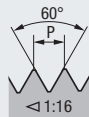

American Tapered Pipe Thread,
ANSI/ASME B1.20.3

For threads without dryseal material,
taper 1:16

Coating

TICN

Applications – Material

P	1.1-5.1	K	1.1-4.2	P	1.1-5.1	M	1.1-4.1
N	1.1-5, 2.1-6	N	3.1-2	K	1.1-4.2	N	1.1-5.2
N	4.1-2, 5.2	S	1.1-3	S	1.1-2.6	H	1.1-2

Nominal Size ø D	T.P.I.	inch			ø d ₁	inch		ø d ₂	mm	Flutes
		l ₁	l ₂	l ₃						
1/16	27	2.362	0.535	1.417	0.232	0.315	8	3		
1/8	27	2.362	0.535	1.417	0.301	0.315	8	3		
1/4	18	3.150	0.804	1.772	0.400	0.472	12	4		
3/8	18	3.150	0.803	1.772	0.439	0.472	12	4		
1/2	14	3.346	1.033	1.890	0.561	0.630	16	4		
3/4	14	3.346	1.033	1.890	0.561	0.630	16	4		
1	11 1/2	3.740	1.258	1.969	0.772	0.787	20	5		
1 1/4	11 1/2									
1 1/2	11 1/2									
2	11 1/2									

GF-KEG-VHM
R15-Ig-1KZ-HB

GF-KEG-VHM
R15-Ig-1KZ-HB
TICN

GF175301.5782	●	GF175306.5782	●
GF175301.5783	●	GF175306.5783	●
GF175311.5784	●	GF175316.5784	●
GF175311.5785	●	GF175316.5785	●
GF175331.5786	●	GF175336.5786	●
GF175331.5787	●	GF175336.5787	●

GF175351.9684	●	GF175356.9684	●
---------------	---	---------------	---

NPTF cutters are manufactured with a corrected profile

Application recommendation: You must have an NC program for a spiral formed helix to prevent a profile step

Thread Hole Preparatory Diameters for Tapered Pipe Thread NPTF, Taper 1:16

A) Cylindrical preparation of thread hole

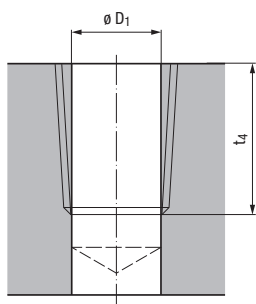

B) Tapered preparation of thread hole

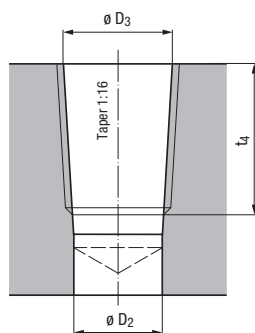

Nominal size ø D	T.P.I.	inch			t ₄
		ø D ₁	ø D ₂	ø D ₃ (+0.002)	
1/16	27	0.2402	0.2343	0.2524	0.3268
1/8	27	0.3327	0.3268	0.3449	0.3268
1/4	18	0.4291	0.4232	0.4488	0.4783
3/8	18	0.5630	0.5571	0.5843	0.4902
1/2	14	0.6929	0.6870	0.7217	0.6417
3/4	14	0.9055	0.8976	0.9323	0.6417
1	11 1/2	1.1319	1.1280	1.1701	0.7697
1 1/4	11 1/2	1.4764	1.4705	1.5150	0.7894
1 1/2	11 1/2	1.7224	1.7106	1.7539	0.7894
2	11 1/2	2.1949	2.1831	2.2280	0.8051

● = In stock
★ = Allow 7 days for delivery

Product Finder

v_c / f_z

UNC

UNF

UN

M

MF

NPSF

Rp (BSPP)

G

W

BSW, BSF

NPT

NPTF

Rc (BSPT)

STI

SELF-LOCK

Accessories

Tech. Info

BGF

ZBGF

GSF (Aero)

GSF-Z

GF(I), GF-Z

GF-Vario-Z

GF-H

GF-KEG

ZGF(I)

CIRC-GF

Gigant

FPC, FMC

MoSys



- Product Finder
- v_c / f_z
- UNC
- UNF
- UN
- M
- MF
- NPSF
- Rp (BSPP)
- G
- W
- BSW, BSF
- NPT
- NPTF
- Rc (BSPT)
- STI
- SELF-LOCK
- Accessories
- Tech. Info
- BGF
- ZBGF
- GSF (Aero)
- GSF-Z
- GF(I), GF-Z
- GF-Vario-Z
- GF-H
- GF-KEG**
- ZGF(I)
- CIRC-GF
- Gigant
- FPC, FMC
- MoSys

Metric Shank

Carbide

R15

RH + LH

3-5 Flutes

DIN 6535



new



new



For internal tapered threads

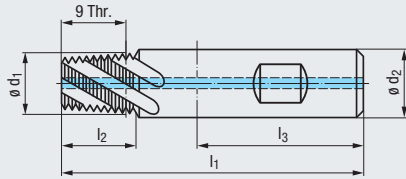

Coating

TICN

Applications – Material

P	1.1-5.1	K	1.1-4.2	P	1.1-5.1	M	1.1-4.1
N	1.1-5, 2.1-6	N	3.1-2	K	1.1-4.2	N	1.1-5.2
N	4.1-2, 5.2	S	1.1-3	S	1.1-2.6	H	1.1-2

NPTF

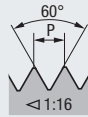

American Tapered Pipe Thread,
ANSI/ASME B1.20.3

For threads without dryseal material,
taper 1:16

Nominal Size ϕD	T.P.I.	inch			ϕd_1	inch		Flutes	GF-KEG-VHM R15-Ig-IKZN-HB		GF-KEG-VHM R15-Ig-IKZN-HB TICN	
		l_1	l_2	l_3		ϕd_2	mm					
1/16	27	2.362	0.535	1.417	0.232	0.315	8	3	GF195301.5782	●	GF195306.5782	●
1/8	27	2.362	0.535	1.417	0.301	0.315	8	3	GF195301.5783	●	GF195306.5783	●
1/4	18	3.150	0.804	1.772	0.400	0.472	12	4	GF195311.5784	●	GF195316.5784	●
3/8	18	3.150	0.803	1.772	0.439	0.472	12	4	GF195311.5785	●	GF195316.5785	●
1/2	14	3.346	1.033	1.890	0.561	0.630	16	4	GF195331.5786	●	GF195336.5786	●
3/4	14	3.346	1.033	1.890	0.561	0.630	16	4	GF195331.5787	●	GF195336.5787	●
1	11 1/2	3.740	1.258	1.969	0.772	0.787	20	5	GF195351.9684	●	GF195356.9684	●
1 1/4	11 1/2											
1 1/2	11 1/2											
2	11 1/2											

NPTF cutters are manufactured with a corrected profile

Application recommendation: You must have an NC program for a spiral formed helix to prevent a profile step

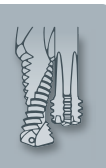

Thread Hole Preparatory Diameters for Tapered Pipe Thread NPTF, Taper 1:16

A) Cylindrical preparation of thread hole

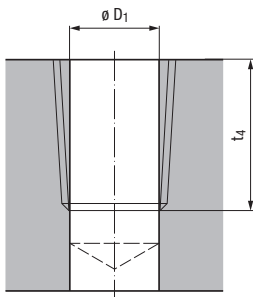

B) Tapered preparation of thread hole

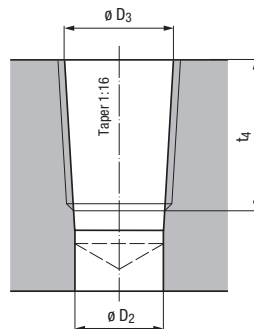

Nominal size ϕD	T.P.I.	inch			
		ϕD_1	ϕD_2	ϕD_3 (+0.002)	t_4
1/16	27	0.2402	0.2343	0.2524	0.3268
1/8	27	0.3327	0.3268	0.3449	0.3268
1/4	18	0.4291	0.4232	0.4488	0.4783
3/8	18	0.5630	0.5571	0.5843	0.4902
1/2	14	0.6929	0.6870	0.7217	0.6417
3/4	14	0.9055	0.8976	0.9323	0.6417
1	11 1/2	1.1319	1.1280	1.1701	0.7697
1 1/4	11 1/2	1.4764	1.4705	1.5150	0.7894
1 1/2	11 1/2	1.7224	1.7106	1.7539	0.7894
2	11 1/2	2.1949	2.1831	2.2280	0.8051

Metric Shank

Carbide

RH + LH

3-5 Flutes



DIN 6535



For internal tapered threads

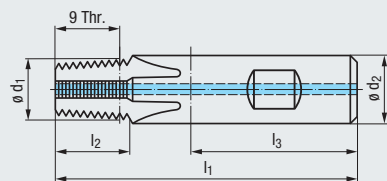

Rc (BSPT)

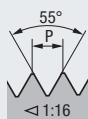

Tapered Whitworth Pipe Thread,
DIN EN ISO 10226-2 and ISO 7-1

Where pressure-tight joints
are made on the threads, taper 1:16

Coating

TiCN

Applications – Material

P	1.1-5.1	K	1.1-4.2	P	1.1-5.1	M	1.1-4.1
N	1.1-5, 2.1-6	N	3.1-2	K	1.1-4.2	N	1.1-5.2
N	4.1-2, 5.2	S	1.1-3	S	1.1-2.6	H	1.1-2

Nominal Size ϕD	T.P.I.	inch			ϕd_1	inch		ϕd_2	mm	Flutes	GF-KEG-VHM IKZ-HB	GF-KEG-VHM IKZ-HB TiCN
		l_1	l_2	l_3		ϕd_1	ϕd_2					
1/16	28	2.165	0.337	1.417	0.232	0.315	8	3		GF173101.4114	GF173106.4114	
1/8	28	2.165	0.337	1.417	0.301	0.315	8	3		GF173101.4115	GF173106.4115	
1/4	19	2.953	0.550	1.772	0.400	0.472	12	4		GF173111.4116	GF173116.4116	
3/8	19	2.953	0.549	1.772	0.439	0.472	12	4		GF173111.4117	GF173116.4117	
1/2	14	3.150	0.750	1.890	0.561	0.630	16	4		GF173131.9561	GF173136.9561	
3/4	14											
1	11	3.543	0.955	1.969	0.772	0.787	20	5		GF173151.9562	GF173156.9562	
1 1/4	11											
1 1/2	11											
2	11											

Rc cutters are manufactured with a corrected profile

Application recommendation: You must have an NC program for a spiral formed helix to prevent a profile step

Thread Hole Preparatory Diameters for Tapered Pipe Thread Rc (BSPT), Taper 1:16

Hole type A) can be used when there is no reason to worry about sealing problems

A) Cylindrical preparation of thread hole

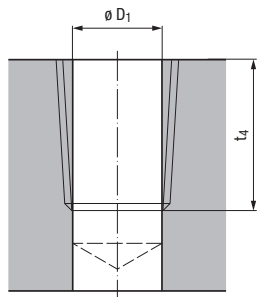

B) Tapered preparation of thread hole

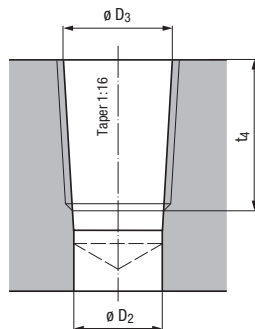

Nominal size ϕD	T.P.I.	ϕD_1	ϕD_2	ϕD_3 (JS11)	t_4
1/16	28	0.2421	0.2402	0.2583	0.3091
1/8	28	0.3209	0.3189	0.3374	0.3091
1/4	19	0.4272	0.4232	0.4508	0.4587
3/8	19	0.5630	0.5610	0.5886	0.4744
1/2	14	0.7008	0.6969	0.7335	0.6260
3/4	14	0.9134	0.9094	0.9496	0.6594
1	11	1.1496	1.1457	1.1925	0.7736
1 1/4	11	1.4882	1.4803	1.5335	0.8642
1 1/2	11	1.7205	1.7126	1.7657	0.8642
2	11	2.1732	2.1654	2.2307	1.0335

● = In stock
★ = Allow 7 days for delivery

- Product Finder
- v_c / f_z
- UNC
- UNF
- UN
- M
- MF
- NPSF
- Rp (BSPP)
- G
- W
- BSW, BSF
- NPT
- NPTF
- Rc (BSPT)
- STI
- SELF-LOCK
- Accessories
- Tech. Info
- BGF
- ZBGF
- GSF (Aero)
- GSF-Z
- GF(I), GF-Z
- GF-Vario-Z
- GF-H
- GF-KEG**
- ZGF(I)
- CIRC-GF
- Gigant
- FPC, FMC
- MoSys



- Product Finder
- v_c / f_z
- UNC
- UNF
- UN
- M
- MF
- NPSF
- Rp (BSPP)
- G
- W
- BSW, BSF
- NPT
- NPTF
- Rc (BSPT)
- STI
- SELF-LOCK
- Accessories
- Tech. Info
- BGF
- ZBGF
- GSF (Aero)
- GSF-Z
- GF(I), GF-Z
- GF-Vario-Z
- GF-H
- GF-KEG**
- ZGF(I)
- CIRC-GF
- Gigant
- FPC, FMC
- MoSys

Metric Shank

Carbide

RH + LH

3-5 Flutes



DIN 6535



new



new



For internal tapered threads

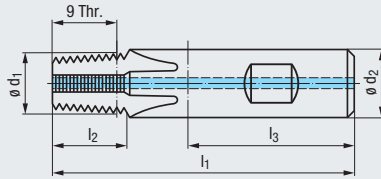

Coating

TICN

Applications – Material

P	1.1-5.1	K	1.1-4.2	P	1.1-5.1	M	1.1-4.1
N	1.1-5, 2.1-6	N	3.1-2	K	1.1-4.2	N	1.1-5.2
N	4.1-2, 5.2	S	1.1-3	S	1.1-2.6	H	1.1-2

RC (BSPT)



Tapered Whitworth Pipe Thread,
DIN EN ISO 10226-2 and ISO 7-1

Where pressure-tight joints
are made on the threads, taper 1:16

Nominal Size ϕD	T.P.I.	inch			ϕd_1	inch		Flutes	GF-KEG-VHM IKZN-HB	GF-KEG-VHM IKZN-HB TICN
		l_1	l_2	l_3		ϕd_2	mm			
1/16	28	2.165	0.337	1.417	0.232	0.315	8	3	GF193101.4114	GF193106.4114
1/8	28	2.165	0.337	1.417	0.301	0.315	8	3	GF193101.4115	GF193106.4115
1/4	19	2.953	0.550	1.772	0.400	0.472	12	4	GF193111.4116	GF193116.4116
3/8	19	2.953	0.549	1.772	0.439	0.472	12	4	GF193111.4117	GF193116.4117
1/2	14	3.150	0.750	1.890	0.561	0.630	16	4	GF193131.9561	GF193136.9561
3/4	14									
1	11	3.543	0.955	1.969	0.772	0.787	20	5	GF193151.9562	GF193156.9562
1 1/4	11									
1 1/2	11									
2	11									

Rc cutters are manufactured with a corrected profile

Application recommendation: You must have an NC program for a spiral formed helix to prevent a profile step

Thread Hole Preparatory Diameters for Tapered Pipe Thread Rc (BSPT), Taper 1:16

Hole type A) can be used when there is no reason to worry about sealing problems

A) Cylindrical preparation of thread hole

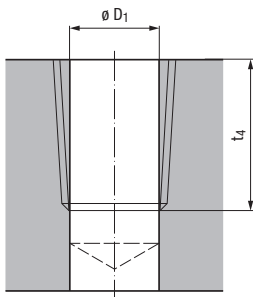

B) Tapered preparation of thread hole

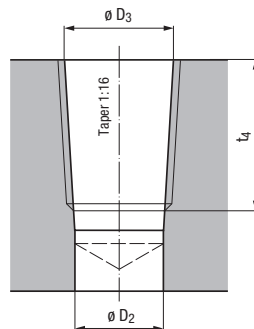

Nominal size ϕD	T.P.I.	inch			t_4
		ϕD_1	ϕD_2	ϕD_3 (JS11)	
1/16	28	0.2421	0.2402	0.2583	0.3091
1/8	28	0.3209	0.3189	0.3374	0.3091
1/4	19	0.4272	0.4232	0.4508	0.4587
3/8	19	0.5630	0.5610	0.5886	0.4744
1/2	14	0.7008	0.6969	0.7335	0.6260
3/4	14	0.9134	0.9094	0.9496	0.6594
1	11	1.1496	1.1457	1.1925	0.7736
1 1/4	11	1.4882	1.4803	1.5335	0.8642
1 1/2	11	1.7205	1.7126	1.7657	0.8642
2	11	2.1732	2.1654	2.2307	1.0335

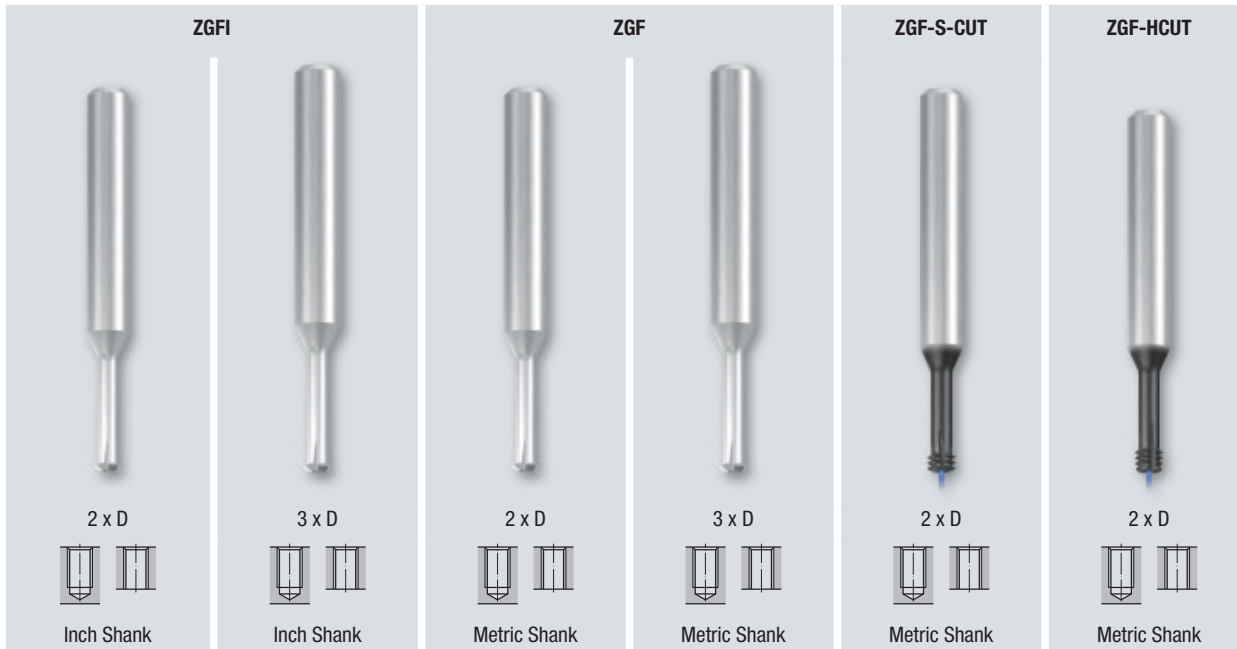

300	301	302	303	304		UNC
300	301	302	303	304		UNF
		305	306 - 307	308	309	M, MF
310						STI-UNC

Product Finder

v_c / f_z

UNC

UNF

UN

M

MF

NPSF

Rp (BSPP)

G

W

BSW, BSF

NPT

NPTF

Rc (BSPT)

STI

SELF-LOCK

Accessories

Tech. Info

BGF

ZBGF

GSF (Aero)

GSF-Z

GF(I), GF-Z

GF-Vario-Z

GF-H

GF(I)-KEG

ZGF(I)

CIRC-GF

Gigant

FPC, FMC

MoSys



Thread milling cycle

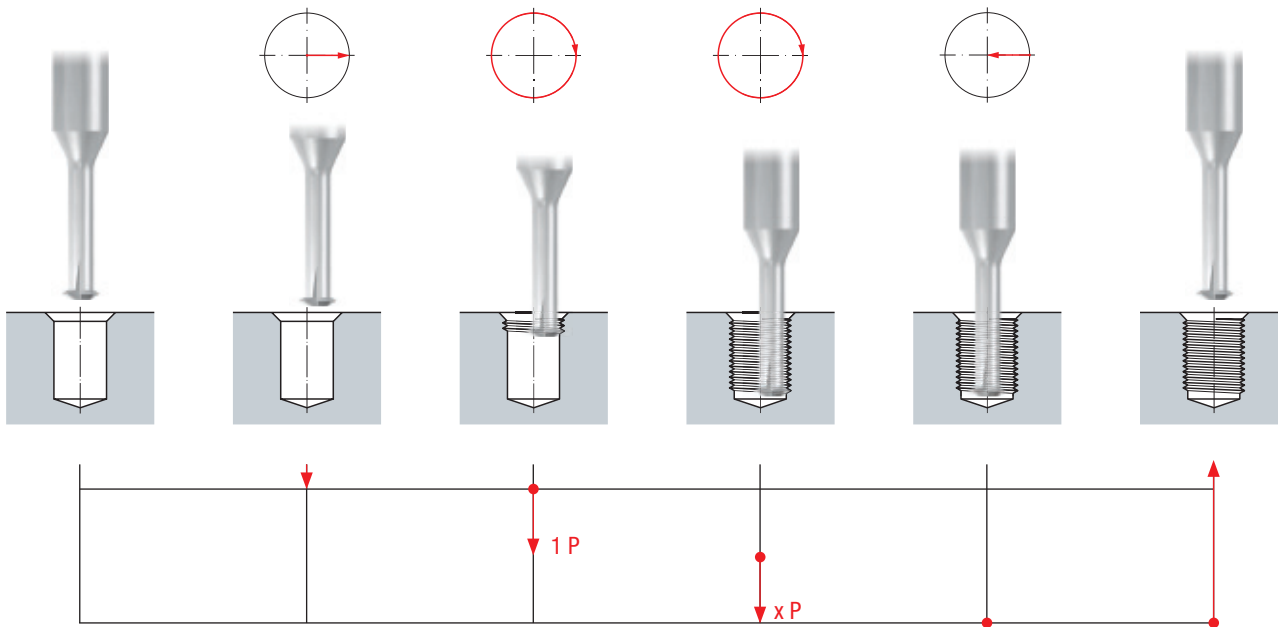

Need programming assistance?

EMUGE's trained thread milling specialist can assist you with advice and guidance in writing the correct program for your CNC machine tool. Thread milling experts will analyze your exact application and help guide you through the proper line code programming.

Contact EMUGE Technical Support department or visit www.emuge.com

- Product Finder
- v_c / f_z
- UNC
- UNF
- UN
- M
- MF
- NPSF
- Rp (BSPP)
- G
- W
- BSW, BSF
- NPT
- NPTF
- Rc (BSPT)
- STI
- SELF-LOCK
- Accessories
- Tech. Info

Inch Shank

Carbide

RH + LH

1-6 Flutes



ASME B94.19



For internal threads

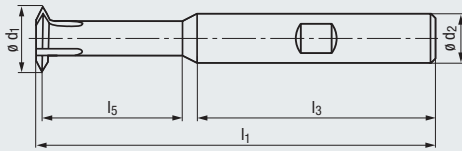

Coating

TiCN

Applications – Material

P 1.1-5.1 M 1.1-4.1 K 1.1-4.2
N 1.1-5.2 S 1.1-2.6 H 1.1-2

UNC, UNF

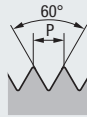

Unified Threads
ASME B1.1

Thread Depth

2 x D

Nominal Size ϕD	T.P.I.	l_1	l_3	inch l_5	ϕd_1	ϕd_2	Flutes	ZGFI-VHM 2xD HA TiCN	ZGFI-VHM 2xD HB TiCN
No. 0	80	1 5/8	1 3/32	0.126	0.045	1/8	1	GFS13706.5033	●
No. 1	64 - 72	1 5/8	1 3/32	0.157	0.056	1/8	3	GFS23706.5000	●
No. 2	56 - 64	1 5/8	1 3/32	0.181	0.065	1/8	3	GFS23706.5001	●
No. 4	40 - 48	1 5/8	1 3/32	0.237	0.081	1/8	3	GFS23706.5003	●
No. 5	40 - 44	1 5/8	1 3/32	0.260	0.094	1/8	3	GFS23706.5004	●
No. 6	32 - 40	1 5/8	1 3/32	0.287	0.100	1/8	3	GFS23706.5005	●
No. 8	32 - 36	1 5/8	1 3/32	0.339	0.122	1/8	3	GFS23706.5006	●
No. 10	24 - 32	2 1/2	1 3/8	0.404	0.136	1/4	3		GFS23106.5007 ●
1/4	20 - 28	2 1/2	1 3/8	0.528	0.185	1/4	3		GFS23106.5009 ●

For internal threads

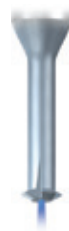
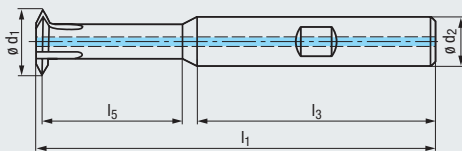

Nominal Size ϕD	T.P.I.	l_1	l_3	inch l_5	ϕd_1	ϕd_2	Flutes	ZGFI-VHM 2xD IKZ-HB TiCN
5/16	18 - 24	2 1/2	1 3/8	0.642	0.242	1/4	4	GFS33106.5010 ●
3/8	16 - 24	2 1/2	1 3/8	0.776	0.301	5/16	5	GFS33106.5011 ●
7/16	14 - 20	3	1 9/16	0.909	0.354	3/8	5	GFS33106.5012 ●
1/2	13 - 20	3 3/4	1 25/32	1.024	0.407	1/2	5	GFS33106.5013 ●
5/8	11 - 18	3 3/4	1 25/32	1.291	0.512	1/2	5	GFS33106.5015 ●
3/4	10 - 16	4 1/4	1 29/32	1.543	0.630	5/8	6	GFS33106.5016 ●

Other sizes upon request

Inch Shank

Carbide

new

RH + LH

3-6 Flutes



ASME B94.19



new



For internal threads

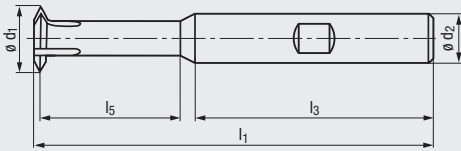

UNC, UNF

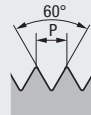

Unified Threads
ASME B1.1

Coating

TICN

Applications – Material

- P 1.1-5.1
- M 1.1-4.1
- K 1.1-4.2
- N 1.1-5.2
- S 1.1-2.6
- H 1.1-2

Thread Depth

3 x D

Nominal Size ø D	T.P.I.	l ₁	l ₃	inch l ₅	ø d ₁	ø d ₂	Flutes	ZGFI-VHM 3xD HA TICN		ZGFI-VHM 3xD HB TICN	
No. 2	56 - 64	1 5/8	1 3/32	0.268	0.067	1/8	3	GFS83706.5001	●		
No. 4	40 - 48	1 5/8	1 3/32	0.349	0.085	1/8	3	GFS83706.5003	●		
No. 6	32 - 40	1 5/8	1 3/32	0.433	0.106	1/8	3	GFS83706.5005	●		
No. 8	32 - 36	1 3/4	1 3/32	0.510	0.132	3/16	3	GFS83706.5006	●		
No. 10	24	1 7/8	1 3/32	0.596	0.146	3/16	3	GFS83706.5007	●		
No. 10	32	1 7/8	1 3/32	0.586	0.154	3/16	4	GFS83706.5041	●		
1/4	20	2 3/8	1 3/8	0.781	0.195	1/4	4			GFS83106.5009	●
1/4	28	2 3/8	1 3/8	0.769	0.207	1/4	4			GFS83106.5043	●

For internal threads

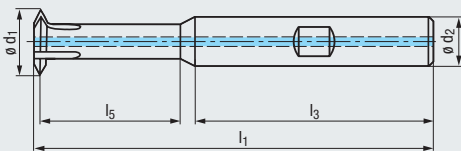

new



Nominal Size ø D	T.P.I.	l ₁	l ₃	inch l ₅	ø d ₁	ø d ₂	Flutes	ZGFI-VHM 3xD IKZ-HB TICN	
5/16	18	2 9/16	1 3/8	0.970	0.248	5/16	4	GFS83106.5010	●
5/16	24	2 9/16	1 3/8	0.962	0.260	5/16	5	GFS83106.5044	●
3/8	16	2 3/4	1 3/8	1.162	0.303	5/16	5	GFS83106.5011	●
3/8	24	2 7/8	1 9/16	1.147	0.323	3/8	5	GFS83106.5045	●
7/16	14	3 1/8	1 9/16	1.352	0.323	3/8	5	GFS83106.5012	●
7/16	20	3 1/16	1 9/16	1.342	0.376	3/8	5	GFS83106.5046	●
1/2	13 - 20	3 5/8	1 25/32	1.543	0.409	1/2	5	GFS83106.5013	●
5/8	11 - 18	4 1/8	1 29/32	1.923	0.514	5/8	5	GFS83106.5015	●
3/4	10 - 16	4 1/2	1 29/32	2.303	0.639	5/8	6	GFS83106.5016	●

Other sizes upon request

Product Finder

v_c / f_z

UNC

UNF

UN

M

MF

NPSF

Rp (BSPP)

G

W

BSW, BSF

NPT

NPTF

Rc (BSPT)

STI

SELF-LOCK

Accessories

Tech. Info

BGF

ZBGF

GSF (Aero)

GSF-Z

GF(I), GF-Z

GF-Vario-Z

GF-H

GF(I)-KEG

ZGFI

CIRC-GF

Gigant

FPC, FMC

MoSys



- Product Finder
- v_c / f_z
- UNC
- UNF
- UN
- M
- MF
- NPSF
- Rp (BSPP)
- G
- W
- BSW, BSF
- NPT
- NPTF
- Rc (BSPT)
- STI
- SELF-LOCK
- Accessories
- Tech. Info
- BGF
- ZBGF
- GSF (Aero)
- GSF-Z
- GF(l), GF-Z
- GF-Vario-Z
- GF-H
- GF(l)-KEG
- ZGF
- CIRC-GF
- Gigant
- FPC, FMC
- MoSys

Metric Shank

For internal threads

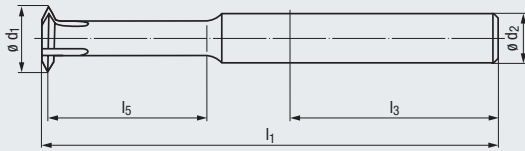

Carbide

RH + LH

3 Flutes



DIN 6535

HA



new



new



UNC, UNF



Unified Threads
ASME B1.1

Coating

TICN

Applications – Material

P	1.1-5.1	K	1.1-4.2	P	1.1-5.1	M	1.1-4.1
N	1.1-5, 2.1-6	N	3.1-2	K	1.1-4.2	N	1.1-5.2
N	4.1-2, 5.2	S	1.1-3	S	1.1-2.6	H	1.1-2

Thread Depth

2 x D

Nominal Size ø D	P _{max.}	l ₁	inch		ø d ₁	ø d ₂		Flutes	ZGF-VHM 2xD HA		ZGF-VHM 2xD HA TICN	
			l ₃	l ₅		inch	mm					
No. 4 - 40	0.025	1.535	1.102	0.250	0.081	0.118	3	3	GF253701.5003	●	GF253706.5003	●
No. 6 - 32	0.031	1.535	1.102	0.276	0.100	0.118	3	3	GF253701.5005	●	GF253706.5005	●
No. 8 - 32	0.031	1.654	1.102	0.329	0.126	0.157	4	3	GF253701.5006	●	GF253706.5006	●

Suitable also for UNF threads

Other sizes upon request

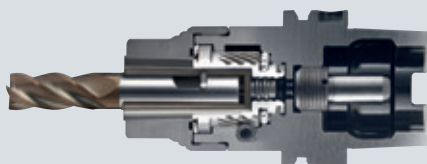
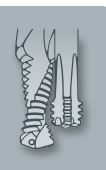

Improve the thread milling process by using a rigid tool holder. The EMUGE FPC chuck provides the accuracy of a shrink-fit holder with the convenience of an hydraulic chuck. See page 338 - 349 for more information.

Metric Shank

Carbide

new

RH + LH

3-5 Flutes



DIN 6535



For internal threads

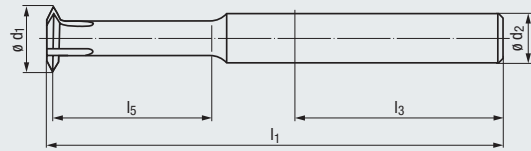

new



UNC



Unified Coarse Thread
ASME B1.1

Coating

TICN

Applications – Material

P 1.1-5.1 M 1.1-4.1 K 1.1-4.2
N 1.1-5.2 S 1.1-2.6 H 1.1-2

Thread Depth

3 x D

Nominal Size ø D	P _{max.}	l ₁	inch l ₃	l ₅	ø d ₁	ø d ₂		Flutes	ZGF-VHM 3xD HA TICN		ZGF-VHM 3xD HB TICN	
						inch	mm					
No. 2 - 56	0.018	1.535	1.102	0.266	0.067	0.118	3	3	GF273706.5001	●		
No. 4 - 40	0.025	1.575	1.102	0.348	0.085	0.118	3	3	GF273706.5003	●		
No. 6 - 32	0.031	1.654	1.102	0.429	0.106	0.118	3	3	GF273706.5005	●		
No. 10 - 24	0.042	1.811	1.102	0.591	0.146	0.157	4	3	GF273706.5007	●		
1/4 - 20	0.050	2.323	1.417	0.793	0.195	0.236	6	4	GF273706.5009	●	GF273106.5009	●
5/16 - 18 1)	0.056	2.559	1.417	0.965	0.248	0.315	8	4	GF273706.5010	●	GF273106.5010	●
3/8 - 16 1)	0.063	2.677	1.417	1.157	0.303	0.315	8	5	GF273706.5011	●	GF273106.5011	●

UNF

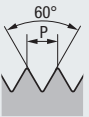

Unified Fine Thread
ASME B1.1

Coating

TICN

Applications – Material

P 1.1-5.1 M 1.1-4.1 K 1.1-4.2
N 1.1-5.2 S 1.1-2.6 H 1.1-2

Thread Depth

3 x D

Nominal Size ø D	P _{max.}	l ₁	inch l ₃	l ₅	ø d ₁	ø d ₂		Flutes	ZGF-VHM 3xD HA TICN		ZGF-VHM 3xD HB TICN	
						inch	mm					
No. 10 - 32	0.031	1.811	1.102	0.585	0.154	0.157	4	4	GF273706.5041	●		
1/4 - 28	0.036	2.323	1.417	0.768	0.207	0.236	6	4	GF273706.5043	●	GF273106.5043	●
5/16 - 24 1)	0.042	2.559	1.417	0.957	0.260	0.315	8	5	GF273706.5044	●	GF273106.5044	●
7/16 - 20 1)	0.050	3.031	1.575	1.337	0.376	0.394	10	5	GF273706.5046	●	GF273106.5046	●

1) Design with internal coolant supply IKZ

Partly suitable also for Metric threads

Other sizes upon request

Product Finder

v_c / f_z

UNC

UNF

UN

M

MF

NPSF

Rp (BSPP)

G

W

BSW, BSF

NPT

NPTF

Rc (BSPT)

STI

SELF-LOCK

Accessories

Tech. Info

BGF

ZBGF

GSF (Aero)

GSF-Z

GF(I), GF-Z

GF-Vario-Z

GF-H

GF(I)-KEG

ZGF

CIRC-GF

Gigant

FPC, FMC

MoSys

- Product Finder
- v_c / f_z
- UNC
- UNF
- UN
- M
- MF
- NPSF
- Rp (BSPP)
- G
- W
- BSW, BSF
- NPT
- NPTF
- Rc (BSPT)
- STI
- SELF-LOCK
- Accessories
- Tech. Info

Metric Shank

For internal threads

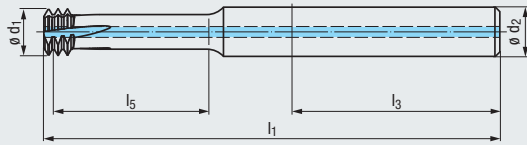

Carbide

new

RH + LH

LH-rot.

L10

3-6 Flutes



DIN 6535



new



UNC



Unified Coarse Thread
ASME B1.1

Coating

TIALN-T46

Applications – Material

P 1.1-5.1 M 1.1-4.1 K 1.1-4.2
N 1.1-5.2 S 1.1-2.6 H 1.1-2

Thread Depth

2 x D

Nominal Size ø D	P _{max.}	l ₁	inch l ₃	l ₅	ø d ₁	ø d ₂		Flutes	ZGF-S-CUT-VHM 2xD IKZ-HA TIALN-T46		ZGF-S-CUT-VHM 2xD IKZ-HB TIALN-T46	
						inch	mm					
No. 4 - 40 ²⁾	0.025	1.535	1.102	0.234	0.085	0.118	3	3	GF26A729.5003	●		
No. 6 - 32 ²⁾	0.031	1.535	1.102	0.287	0.106	0.118	3	3	GF26A729.5005	●		
No. 10 - 24 ²⁾	0.042	1.654	1.102	0.398	0.146	0.157	4	3	GF26A729.5007	●		
1/4 - 20	0.050	2.165	1.417	0.520	0.195	0.236	6	3	GF26A729.5009	●	GF26A129.5009	●
5/16 - 18	0.056	2.283	1.417	0.648	0.248	0.315	8	4	GF26A729.5010	●	GF26A129.5010	●
3/8 - 16	0.063	2.441	1.417	0.774	0.303	0.315	8	4	GF26A729.5011	●	GF26A129.5011	●

- BGF
- ZBGF
- GSF (Aero)
- GSF-Z
- GF(I), GF-Z
- GF-Vario-Z
- GF-H
- GF(I)-KEG
- ZGF
- CIRC-GF
- Gigant
- FPC, FMC
- MoSys

UNF



Unified Fine Thread
ASME B1.1

Coating

TIALN-T46

Applications – Material

P 1.1-5.1 M 1.1-4.1 K 1.1-4.2
N 1.1-5.2 S 1.1-2.6 H 1.1-2

Thread Depth

2 x D

Nominal Size ø D	P _{max.}	l ₁	inch l ₃	l ₅	ø d ₁	ø d ₂		Flutes	ZGF-S-CUT-VHM 2xD IKZ-HA TIALN-T46		ZGF-S-CUT-VHM 2xD IKZ-HB TIALN-T46	
						inch	mm					
No. 10 - 32 ²⁾	0.031	1.654	1.102	0.392	0.154	0.157	4	4	GF26A729.5041	●		
1/4 - 28	0.036	2.165	1.417	0.516	0.207	0.236	6	5	GF26A729.5043	●	GF26A129.5043	●
5/16 - 24	0.042	2.283	1.417	0.642	0.260	0.315	8	5	GF26A729.5044	●	GF26A129.5044	●
7/16 - 20	0.050	2.913	1.575	0.896	0.376	0.394	10	6	GF26A729.5046	●	GF26A129.5046	●

new



new



²⁾ Design without internal coolant supply IKZ

Other sizes upon request

Metric Shank

Carbide

RH + LH

1-5 Flutes

DIN 6535

HA HB

ø D

For internal threads

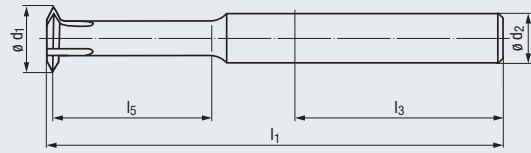

new



M, MF

ISO Metric Threads
DIN 13

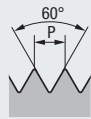

Coating

Applications – Material

P 1.1-5.1 K 1.1-4.2 N 1.1-5, 2.1-6
N 3.1-2 N 4.1-2, 5.2 S 1.1-3

Thread Depth

2 x D

Nominal Size ø D	P _{max.} mm	l ₁	l ₃	mm l ₅	ø d ₁	ø d ₂	Flutes	ZGF-VHM 2xD	
								HA	HB
M1 - M1.2	0.25	39	28	2.8	0.7	3	1	GF243701.0010	●
M1.4 - M1.8	0.35	39	28	3.5	1.04	3	2	GF253701.0014	●
M2 - M2.3	0.45	39	28	4.8	1.52	3	3	GF253701.0020	●
M2.5 - M3	0.5	39	28	6	1.95	3	3	GF253701.0025	●
M3.5 - M4.5	0.75	42	28	9	2.78	4	3	GF253701.0035	●
M5 - M7	1	55	36	14	4	6	4	GF253701.0050	● GF253101.0050 ●
M8 - M10 ¹⁾	1.5	62	36	19.8	6.5	8	5	GF253701.0080	● GF253101.0080 ●
M12 - M16 ¹⁾	2	78	40	31.8	9.9	10	5	GF253701.0112	● GF253101.0112 ●

Coating

Applications – Material

TICN
P 1.1-5.1 M 1.1-4.1 K 1.1-4.2
N 1.1-5.2 S 1.1-2.6 H 1.1-2

Thread Depth

2 x D

Nominal Size ø D	P _{max.} mm	l ₁	l ₃	mm l ₅	ø d ₁	ø d ₂	Flutes	ZGF-VHM 2xD	
								HA TICN	HB TICN
M1 - M1.2	0.25	39	28	2.8	0.7	3	1	GF243706.0010	●
M1.4 - M1.8	0.35	39	28	3.5	1.04	3	2	GF253706.0014	●
M2 - M2.3	0.45	39	28	4.8	1.52	3	3	GF253706.0020	●
M2.5 - M3	0.5	39	28	6	1.95	3	3	GF253706.0025	●
M3.5 - M4.5	0.75	42	28	9	2.78	4	3	GF253706.0035	●
M5 - M7	1	55	36	14	4	6	4	GF253706.0050	● GF253106.0050 ●
M8 - M10 ¹⁾	1.5	62	36	19.8	6.5	8	5	GF253706.0080	● GF253106.0080 ●
M12 - M16 ¹⁾	2	78	40	31.8	9.9	10	5	GF253706.0112	● GF253106.0112 ●

¹⁾ Design with internal coolant supply IKZ

Partly suitable also for UN threads

Other sizes upon request

● = In stock
★ = Allow 7 days for delivery

Product Finder

v_c / f_z

UNC

UNF

UN

M

MF

NPSF

Rp (BSPP)

G

W

BSW, BSF

NPT

NPTF

Rc (BSPT)

STI

SELF-LOCK

Accessories

Tech. Info

BGF

ZBGF

GSF (Aero)

GSF-Z

GF(I), GF-Z

GF-Vario-Z

GF-H

GF(I)-KEG

ZGF

CIRC-GF

Gigant

FPC, FMC

MoSys



- Product Finder
- v_c / f_z
- UNC
- UNF
- UN
- M**
- MF**
- NPSF
- Rp (BSPP)
- G
- W
- BSW, BSF
- NPT
- NPTF
- Rc (BSPT)
- STI
- SELF-LOCK
- Accessories
- Tech. Info

Metric Shank

Carbide

new

RH + LH

1-5 Flutes



DIN 6535



For internal threads

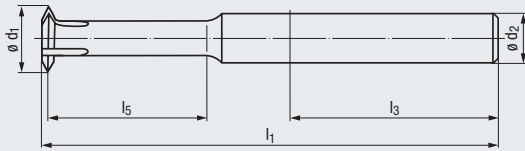

Coating

Applications – Material

P 1.1-5.1 K 1.1-4.2 N 1.1-5, 2.1-6
N 3.1-2 N 4.1-2, 5.2 S 1.1-3

M, MF



ISO Metric Threads
DIN 13

Thread Depth

3 x D

Nominal Size ø D	P _{max.} mm	l ₁	l ₃	mm l ₅	ø d ₁	ø d ₂	Flutes	ZGF-VHM 3xD HA	
M1	0.25	39	28	3.1	0.7	3	1	GF273701.0010	●
M1.6	0.35	39	28	4.95	1.18	3	2	GF273701.0016	●
M2	0.4	39	28	6.2	1.52	3	3	GF273701.0020	●
M2.5	0.45	39	28	7.7	1.96	3	3	GF273701.0025	●
M3	0.5	41	28	9.25	2.4	3	3	GF273701.0030	●
M4	0.7	44	28	12.35	3.15	4	3	GF273701.0040	●
M5	0.8	56	36	15.4	4.04	6	4	GF273701.0050	●
M6	1	59	36	18.5	4.8	6	4	GF273701.0060	●
M8	1.25	65	36	24.65	6.5	8	5	GF273701.0080	●
M10 ¹⁾	1.5	77	40	30.75	8.2	10	5	GF273701.0100	●
M12 ¹⁾	1.75	82	40	36.85	9.9	10	5	GF273701.0112	●
M14 ¹⁾	2	94	45	43	11.6	12	5	GF273701.0114	●
M16 ¹⁾	2	100	45	49	13.6	14	5	GF273701.0116	●

¹⁾ Design with internal coolant supply IKZ

Partly suitable also for UN threads

Other sizes upon request

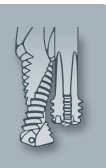

Metric Shank

For internal threads

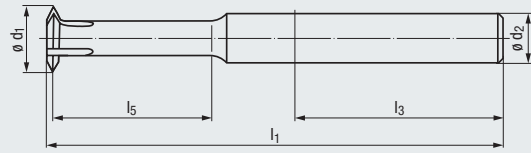

Carbide

new

RH + LH

new

1-5 Flutes



DIN 6535



M, MF



ISO Metric Threads
DIN 13

Coating

TICN

Applications – Material

P	1.1-5.1	M	1.1-4.1	K	1.1-4.2
N	1.1-5.2	S	1.1-2.6	H	1.1-2

Thread Depth

3 x D

Nominal Size ø D	P _{max.} mm	l ₁	l ₃	mm l ₅	ø d ₁	ø d ₂	Flutes	ZGF-VHM 3xD	
								HA TICN	HB TICN
M1	0.25	39	28	3.1	0.7	3	1	GF273706.0010	●
M1.6	0.35	39	28	4.95	1.18	3	2	GF273706.0016	●
M2	0.4	39	28	6.2	1.52	3	3	GF273706.0020	●
M2.5	0.45	39	28	7.7	1.96	3	3	GF273706.0025	●
M3	0.5	41	28	9.25	2.4	3	3	GF273706.0030	●
M4	0.7	44	28	12.35	3.15	4	3	GF273706.0040	●
M5	0.8	56	36	15.4	4.04	6	4	GF273706.0050	●
M6	1	59	36	18.5	4.8	6	4	GF273706.0060	●
M8 ¹⁾	1.25	65	36	24.65	6.5	8	5	GF273706.0080	●
M10 ¹⁾	1.5	77	40	30.75	8.2	10	5	GF273706.0100	●
M12 ¹⁾	1.75	82	40	36.85	9.9	10	5	GF273706.0112	●
M14 ¹⁾	2	94	45	43	11.6	12	5	GF273706.0114	●
M16 ¹⁾	2	100	45	49	13.6	14	5	GF273706.0116	●

¹⁾ Design with internal coolant supply IKZ

Partly suitable also for UN threads

Other sizes upon request

Product Finder

v_c / f_z

UNC

UNF

UN

M

MF

NPSF

Rp (BSPP)

G

W

BSW, BSF

NPT

NPTF

Rc (BSPT)

STI

SELF-LOCK

Accessories

Tech. Info

BGF

ZBGF

GSF (Aero)

GSF-Z

GF(I), GF-Z

GF-Vario-Z

GF-H

GF(I)-KEG

ZGF

CIRC-GF

Gigant

FPC, FMC

MoSys



- Product Finder
- v_c / f_z
- UNC
- UNF
- UN
- M
- MF
- NPSF
- Rp (BSPP)
- G
- W
- BSW, BSF
- NPT
- NPTF
- Rc (BSPT)
- STI
- SELF-LOCK
- Accessories
- Tech. Info
- BGF
- ZBGF
- GSF (Aero)
- GSF-Z
- GF(I), GF-Z
- GF-Vario-Z
- GF-H
- GF(I)-KEG
- ZGF
- CIRC-GF
- Gigant
- FPC, FMC
- MoSys

Metric Shank

For internal threads

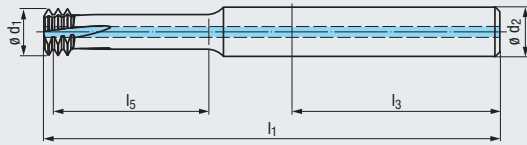

M, MF

ISO Metric Threads
DIN 13

Carbide

new

RH + LH

LH-rot.

L10

4-5 Flutes

DIN 6535

HA
HB

ø D

new



Coating

TIALN-T46

Applications – Material

P 1.1-5.1 M 1.1-4.1 K 1.1-4.2
N 1.1-5.2 S 1.1-2.6 H 1.1-2

Thread Depth

2 x D

Nominal Size ø D	P _{max.} mm	l ₁	l ₃	mm l ₅	ø d ₁	ø d ₂	Flutes	ZGF-S-CUT-VHM 2xD	
								IKZ-HA TIALN-T46	IKZ-HB TIALN-T46
M 3 ²⁾	0.5	39	28	6.2	2.4	3	4	GF26A729.0030	●
M 4 ²⁾	0.7	42	28	8.3	3.15	4	4	GF26A729.0040	●
M 5	0.8	52	36	10.3	4.04	6	4	GF26A729.0050	● GF26A129.0050 ●
M 6	1	55	36	12.43	4.8	6	4	GF26A729.0060	● GF26A129.0060 ●
M 8	1.25	60	36	16.7	6.5	8	4	GF26A729.0080	● GF26A129.0080 ●
M10	1.5	70	40	20.7	8.2	10	5	GF26A729.0100	● GF26A129.0100 ●

²⁾ Design without internal coolant supply IKZ

Other sizes upon request

Metric Shank

Carbide

new

RH + LH

LH-rot.

L10

4-5 Flutes



DIN 6535



For internal threads

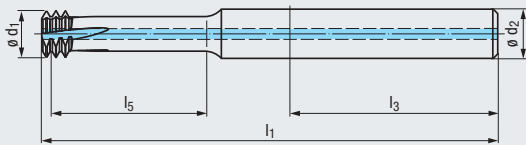

Coating

TIALN-T46

Applications – Material

H 1.1-5

Thread Depth

2 x D

M, MF

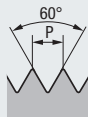

ISO Metric Threads
DIN 13

Nominal Size ø D	P _{max.} mm	l ₁	l ₃	mm l ₅	ø d ₁	ø d ₂	Flutes	ZGF-HCUT-VHM 2xD IKZ-HA TIALN-T46		ZGF-HCUT-VHM 2xD IKZ-HB TIALN-T46	
								●	●	●	●
M 3 ²⁾	0.5	51	36	6.25	2.4	6	4	GF283729.0030	●	GF283129.0030	●
M 4 ²⁾	0.7	51	36	8.35	3.15	6	4	GF283729.0040	●	GF283129.0040	●
M 5	0.8	52	36	10.4	4.04	6	4	GF283729.0050	●	GF283129.0050	●
M 6	1	55	36	12.3	4.8	6	4	GF283729.0060	●	GF283129.0060	●
M 8	1.25	60	36	16.6	6.5	8	4	GF283729.0080	●	GF283129.0080	●
M10	1.5	70	40	20.75	8.2	10	5	GF283729.0100	●	GF283129.0100	●
M12	1.75	74	40	24.85	9.9	10	5	GF283729.0112	●	GF283129.0112	●
M14	2	85	45	29	11.6	12	5	GF283729.0114	●	GF283129.0114	●
M16	2	90	45	33	13.6	14	5	GF283729.0116	●	GF283129.0116	●

²⁾ Design without internal coolant supply IKZ

Other sizes upon request

Product Finder

v_c / f_z

UNC

UNF

UN

M

MF

NPSF

Rp (BSPP)

G

W

BSW, BSF

NPT

NPTF

Rc (BSPT)

STI

SELF-LOCK

Accessories

Tech. Info

BGF

ZBGF

GSF (Aero)

GSF-Z

GF(I), GF-Z

GF-Vario-Z

GF-H

GF(I)-KEG

ZGF

CIRC-GF

Gigant

FPC, FMC

MoSys



- Product Finder
- v_c / f_z
- UNC
- UNF
- UN
- M
- MF
- NPSF
- Rp (BSPP)
- G
- W
- BSW, BSF
- NPT
- NPTF
- Rc (BSPT)
- STI**
- SELF-LOCK
- Accessories
- Tech. Info
- BGF
- ZBGF
- GSF (Aero)
- GSF-Z
- GF(I), GF-Z
- GF-Vario-Z
- GF-H
- GF(I)-KEG
- ZGFI**
- CIRC-GF
- Gigant
- FPC, FMC
- MoSys

Inch Shank

Carbide

RH + LH

3 Flutes



ASME B94.19



ϕD



For internal threads

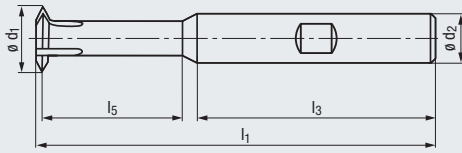

Coating

TiCN

Applications – Material

- P 1.1-5.1
- M 1.1-4.1
- K 1.1-4.2
- N 1.1-5.2
- S 1.1-2.6
- H 1.1-2

STI-UNC

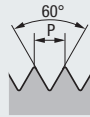

Unified Coarse Thread
ASME B18.29.1

For wire thread inserts



Thread Depth



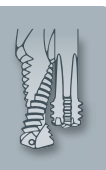

2 x D

Nominal Size ϕD	T.P.I.	l_1	l_3	inch l_5	ϕd_1	ϕd_2	Flutes	ZGFI-VHM	
								2xD HA TiCN	2xD HB TiCN
STI-No. 4	40	1 5/8	1 3/32	0.291	0.117	1/8	3	GFS23706.5611	●
STI-No. 6	32	2 1/2	1 3/8	0.366	0.143	1/4	3		GFS23106.5613 ●
STI-No. 8	32	2 1/2	1 3/8	0.417	0.167	1/4	3		GFS23106.5614 ●

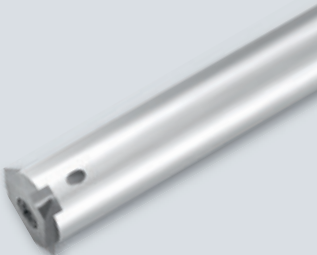
Other sizes upon request

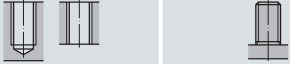

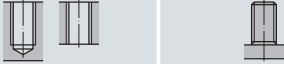
<p>Circular Thread Milling Bodies with 1 Insert 15 mm</p> <p>CIRC-GF</p> 	<p>Circular Thread Milling Bodies with 2 Inserts 15 mm</p> <p>CIRC-GF</p> 	<p>Circular Thread Milling Bodies with 1 Insert 26 mm</p> <p>CIRC-GF</p> 	<p>Circular Thread Milling Bodies with Indexable Infeed Insert "3-Tooth"</p> <p>CIRC-GF 1)</p> 
Page			
312	312	314	315

<p>Standard Inserts 15 mm</p>  	<p>Long Inserts 26 mm</p>  	<p>Indexable Infeed Inserts, "3-Tooth" Design</p>  			
Page					
313					UN
313		314		315	M, MF
313	313	314	314	315	G (BSP), BSW, BSF, W

1) Thread milling cycle corresponding to that of the Gigant design, see page 316

Thread milling cycle

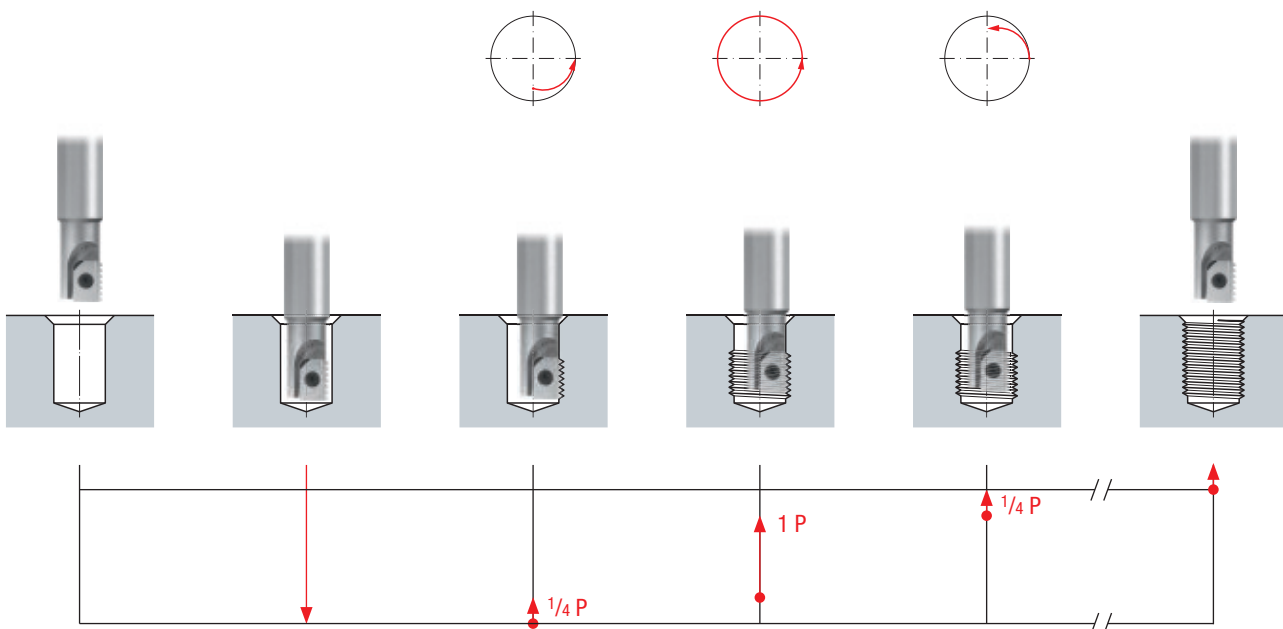

Product Finder

v_c / f_z

UNC

UNF

UN

M

MF

NPSF

Rp (BSPP)

G

W

BSW, BSF

NPT

NPTF

Rc (BSPT)

STI

SELF-LOCK

Accessories

Tech. Info

BGF

ZBGF

GSF (Aero)

GSF-Z

GF(I), GF-Z

GF-Vario-Z

GF-H

GF(I)-KEG

ZGF(I)

CIRC-GF

Gigant

FPC, FMC

MoSys

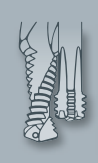

- Product Finder
- v_c / f_z
- UNC
- UNF
- UN
- M
- MF
- NPSF
- Rp (BSPP)
- G
- W
- BSW, BSF
- NPT
- NPTF
- Rc (BSPT)
- STI
- SELF-LOCK
- Accessories
- Tech. Info
- BGF
- ZBGF
- GSF (Aero)
- GSF-Z
- GF(I), GF-Z
- GF-Vario-Z
- GF-H
- GF(I)-KEG
- ZGF(I)
- CIRC-GF
- Gigant
- FPC, FMC
- MoSys

Design for 1 standard insert 15 mm

DIN 1835
B



Short design

P mm	l_1	l_2	l_3	mm l_5	$\varnothing d_1$	$\varnothing d_2$	$\varnothing d_3$	CIRC-GF 15 mm-Z1 IKZN
0.5 - 2.5	78	15	48	30	16	16	13	GZ301110 ●

Long design

P mm	l_1	l_2	l_3	mm l_5	$\varnothing d_1$	$\varnothing d_2$	$\varnothing d_3$	CIRC-GF 15 mm-Z1 IKZN
0.5 - 2.5	98	15	48	50	16	16	13	GZ301310 ²⁾ ●
0.5 - 2.5	110	15	50	60	20	20	17	GZ301320 ●
3.0 - 3.5 ¹⁾	110	15	50	60	22	20	17	GZ301340 ●

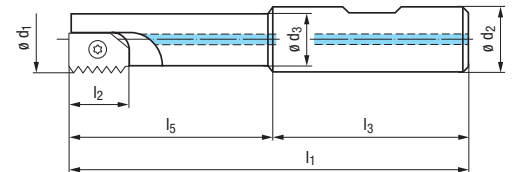
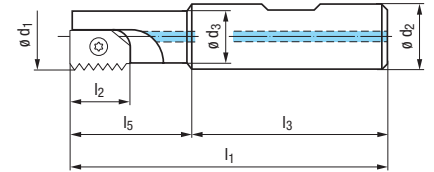

Design for 2 standard inserts 15 mm

DIN 1835
B



Short design

P mm	l_1	l_2	l_3	mm l_5	$\varnothing d_1$	$\varnothing d_2$	$\varnothing d_3$	CIRC-GF 15 mm-Z2 IKZN
0.5 - 2.5	106	15	56	50	25	25	21	GZ301130 ●
3.0 - 3.5 ¹⁾	106	15	56	50	27	25	21	GZ301140 ●

Long design

P mm	l_1	l_2	l_3	mm l_5	$\varnothing d_1$	$\varnothing d_2$	$\varnothing d_3$	CIRC-GF 15 mm-Z2 IKZN
0.5 - 2.5	150	15	56	94	25	25	21	GZ301330 ²⁾ ●

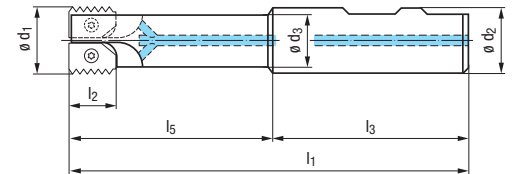
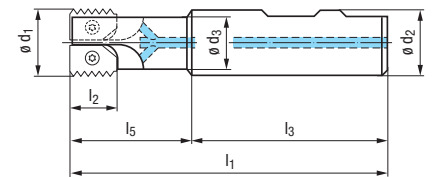

1) Reinforced design
2) Of vibration-absorbing heavy metal

UN

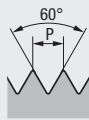

Unified Threads
ASME B1.1

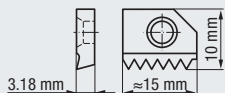

Carbide RH + LH

For internal threads

Standard inserts 15 mm



Coating

TIALN-T4

Range of Application

P 1.1-5.1 K 1.1-4.2 N 1.1-5 M 1.1-5.1 M 1.1-4.1 K 1.1-4.2
N 2.1-6 N 3.1-4.2, 5.2 S 1.1-3 N 1.1-5.2 S 1.1-2.6 H 1.1-2

T.P.I.

HM-FP-Z1
15 mm

HM-FP-Z1
15 mm
TIALN-T4

20	GF603111.9580	●	GF603117.9580	
16	GF603111.9582	●	GF603117.9582	
14	GF603111.9583	●	GF603117.9583	
12	GF603111.9585	●	GF603117.9585	●

M, MF

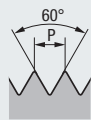

ISO Metric Threads
DIN 13



Carbide RH + LH

For internal threads

Standard inserts 15 mm



Coating

TIALN-T4

Range of Application

P 1.1-5.1 K 1.1-4.2 N 1.1-5 M 1.1-5.1 M 1.1-4.1 K 1.1-4.2
N 2.1-6 N 3.1-4.2, 5.2 S 1.1-3 N 1.1-5.2 S 1.1-2.6 H 1.1-2

P
mm

HM-FP-Z1
15 mm

HM-FP-Z1
15 mm
TIALN-T4

0.5	GF603111.9506	●	GF603117.9506	
0.75	GF603111.9509	●	GF603117.9509	
1	GF603111.9512	●	GF603117.9512	●
1.25	GF603111.9513	●	GF603117.9513	
1.5	GF603111.9514	●	GF603117.9514	●
1.75	GF603111.9515	●	GF603117.9515	
2	GF603111.9516	●	GF603117.9516	●
2.5	GF603111.9517	●	GF603117.9517	●
3 ¹⁾	GF603111.9518	●	GF603117.9518	●
3.5 ¹⁾	GF603111.9519	●	GF603117.9519	●

**G (BSP),
BSW, BSF, W**

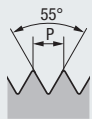

Whitworth Pipe Threads
DIN EN ISO 228, BS 84

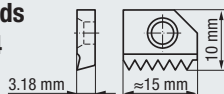

Carbide RH + LH

For internal and external threads

Standard inserts 15 mm



Coating

TIALN-T4

Range of Application

P 1.1-5.1 K 1.1-4.2 N 1.1-5 M 1.1-5.1 M 1.1-4.1 K 1.1-4.2
N 2.1-6 N 3.1-4.2, 5.2 S 1.1-3 N 1.1-5.2 S 1.1-2.6 H 1.1-2

T.P.I.

HM-FP-Z1
15 mm

HM-FP-Z1
15 mm
TIALN-T4

14	GF603111.9548	●	GF603117.9548	●
11	GF603111.9550	●	GF603117.9550	●

Accessories



GZ309010 Spare screw M4 x 7; Torx T15



GZ309020 Screw driver Torx T15

● = In stock
★ = Allow 7 days for delivery

- Product Finder
- v_c / f_z
- UNC
- UNF
- UN
- M
- MF
- NPSF
- Rp (BSPF)
- G
- W
- BSW, BSF
- NPT
- NPTF
- Rc (BSPT)
- STI
- SELF-LOCK
- Accessories
- Tech. Info
- BGF
- ZBGF
- GSF (Aero)
- GSF-Z
- GF(I), GF-Z
- GF-Vario-Z
- GF-H
- GF(I)-KEG
- ZGF(I)
- CIRC-GF
- Gigant
- FPC, FMC
- MoSys



- Product Finder
- v_c / f_z
- UNC
- UNF
- UN
- M
- MF
- NPSF
- Rp (BSPP)
- G
- W
- BSW, BSF
- NPT
- NPTF
- Rc (BSPT)
- STI
- SELF-LOCK
- Accessories
- Tech. Info

Design for 1 long insert 26 mm

DIN 1835



Short design

P mm	l_1	l_2	l_3	mm l_5	$\varnothing d_1$	$\varnothing d_2$	$\varnothing d_3$	CIRK-GF 26 mm-Z1 IKZN
1 - 4	107	26	56	48	25	25	20	GZ303010 ●

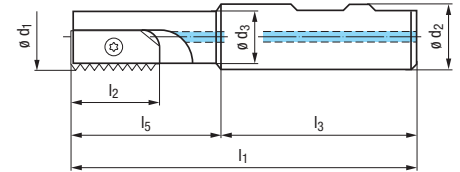

M, MF

ISO Metric Threads
DIN 13

Carbide

RH + LH

For internal threads

Long inserts 26 mm



	Coating	TIALN-T4		
	Range of Application	P 1.1-5.1	M 1.1-4.1	K 1.1-4.2
		N 1.1-5.2	S 1.1-2.6	H 1.1-2
	T.P.I.	HM-FP-Z1 26 mm TIALN-T4		
	1.5	GF603147.9514	●	
	2	GF603147.9516	●	
	2.5	GF603147.9517	●	
	3	GF603147.9518	●	
	3.5	GF603147.9519	●	
	4	GF603147.9520	●	

G (BSP), BSW, BSF, W

Whitworth Pipe Threads
DIN EN ISO 228, BS 84

Carbide

RH + LH

For internal and external threads

Long inserts 26 mm



	Coating	TIALN-T4		
	Range of Application	P 1.1-5.1	M 1.1-4.1	K 1.1-4.2
		N 1.1-5.2	S 1.1-2.6	H 1.1-2
	P mm	HM-FP-Z1 26 mm TIALN-T4		
	14	GF603147.9548	●	
	11	GF603147.9550	●	

Accessories



For indexable infeed inserts, "3-tooth" design

DIN 6535

HB

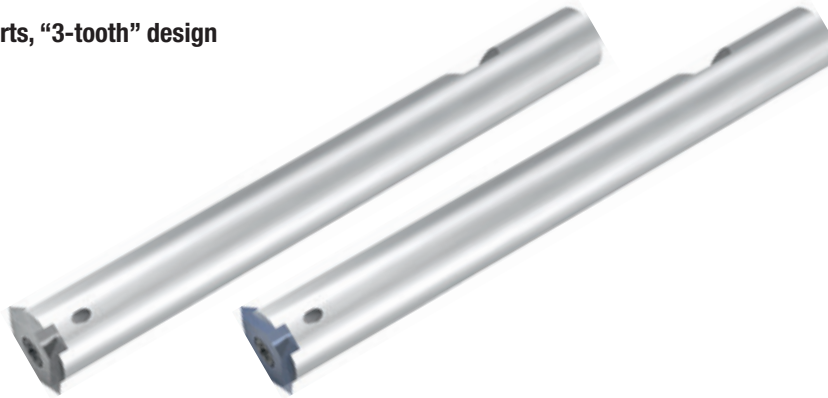

Carbide design

Insert Size	l_1	l_3	l_5	ϕd_2	CIRC-GF Size 02 IKZN
02	112	45	67	12	GZ311330 ●

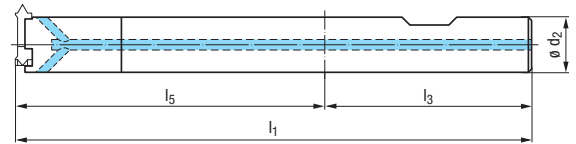

M, MF

ISO Metric Threads
DIN 13

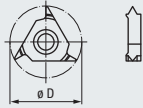
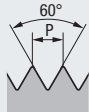

Carbide

RH + LH



For internal threads

Indexable infeed inserts, "3-tooth" design



Coating

Range of Application

TIALN-T4
 P 1.1-5.1 K 1.1-4.2 N 1.1-5 P 1.1-5.1 M 1.1-4.1 K 1.1-4.2
 N 2.1-6 N 3.1-4.2, 5.2 S 1.1-3 N 1.1-5.2 S 1.1-2.6 H 1.1-2

Insert Size	P mm	ϕD
02	1 - 3.5	17.5
02	3	17.5
02	2.5 (M20)	16

HM-EP-Z3
Size 02

HM-EP-Z3
Size 02
TIALN-T4

GF613121.9512 ●	GF613127.9512 ●
GF613121.9518 ●	GF613127.9518 ●
GF613121.0120 ●	GF613127.0120 ●

**G (BSP),
BSW, BSF, W**

Whitworth Pipe Threads
DIN EN ISO 228, BS 84

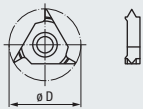
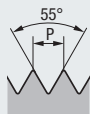

Carbide

RH + LH



For internal and external threads

Indexable infeed inserts, "3-tooth" design



Coating

Range of Application

TIALN-T4
 P 1.1-5.1 K 1.1-4.2 N 1.1-5 P 1.1-5.1 M 1.1-4.1 K 1.1-4.2
 N 2.1-6 N 3.1-4.2, 5.2 S 1.1-3 N 1.1-5.2 S 1.1-2.6 H 1.1-2

Insert Size	T.P.I.	ϕD
02	14	17.5
02	11	17.5

HM-EP-Z3
Size 02

HM-EP-Z3
Size 02
TIALN-T4

GF613121.9548 ●	GF613127.9548 ●
GF613121.9550 ●	GF613127.9550 ●

Accessories



GZ319020 Spare screw M4 x 11; Torx T15



GZ319060 Screw driver Torx T15

● = In stock
★ = Allow 7 days for delivery

- Product Finder
- v_c / f_z
- UNC
- UNF
- UN
- M
- MF
- NPSF
- Rp (BSPP)
- G
- W
- BSW, BSF
- NPT
- NPTF
- Rc (BSPT)
- STI
- SELF-LOCK
- Accessories
- Tech. Info
- BGF
- ZBGF
- GSF (Aero)
- GSF-Z
- GF(I), GF-Z
- GF-Vario-Z
- GF-H
- GF(I)-KEG
- ZGF(I)
- CIRC-GF
- Gigant
- FPC, FMC
- MoSys



Product Finder

v_c / f_z

UNC

UNF

UN

M

MF

NPSF

Rp (BSPP)

G

W

BSW, BSF

NPT

NPTF

Rc (BSPT)

STI

SELF-LOCK

Accessories

Tech. Info

BGF

ZBGF

GSF (Aero)

GSF-Z

GF(I), GF-Z

GF-Vario-Z

GF-H

GF(I)-KEG

ZGF(I)

CIRC-GF

Gigant

FPC, FMC

MoSys

Tool description:

Circular thread milling bodies with exchangeable inserts for the production of large internal and external threads (from M20). The inserts can mostly be used universally (they are not limited to a single pitch). A ready prepared thread hole, countersunk if necessary, is needed.

Application range:

Low- and high-alloyed steels up to 1400 N/mm², stainless steel materials, cast materials, aluminum alloys, copper alloys, magnesium alloys, synthetics as well as titanium alloys.

Thread milling cycle

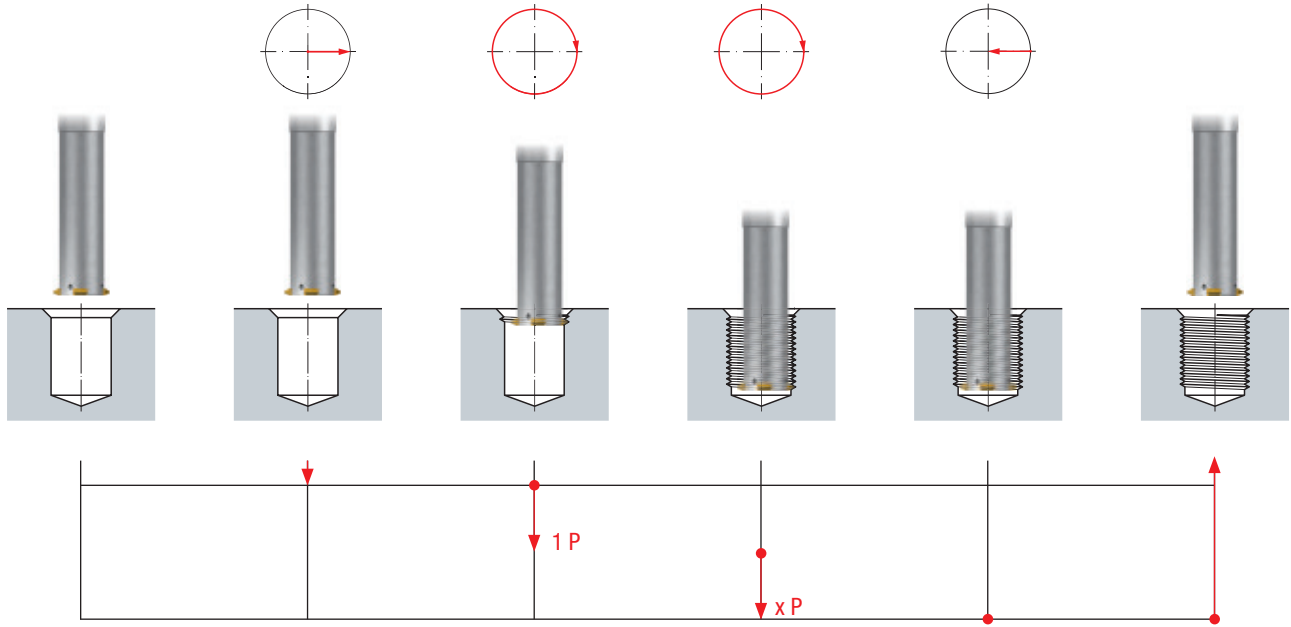

Thread milling cycle

Gigant modular sprinter

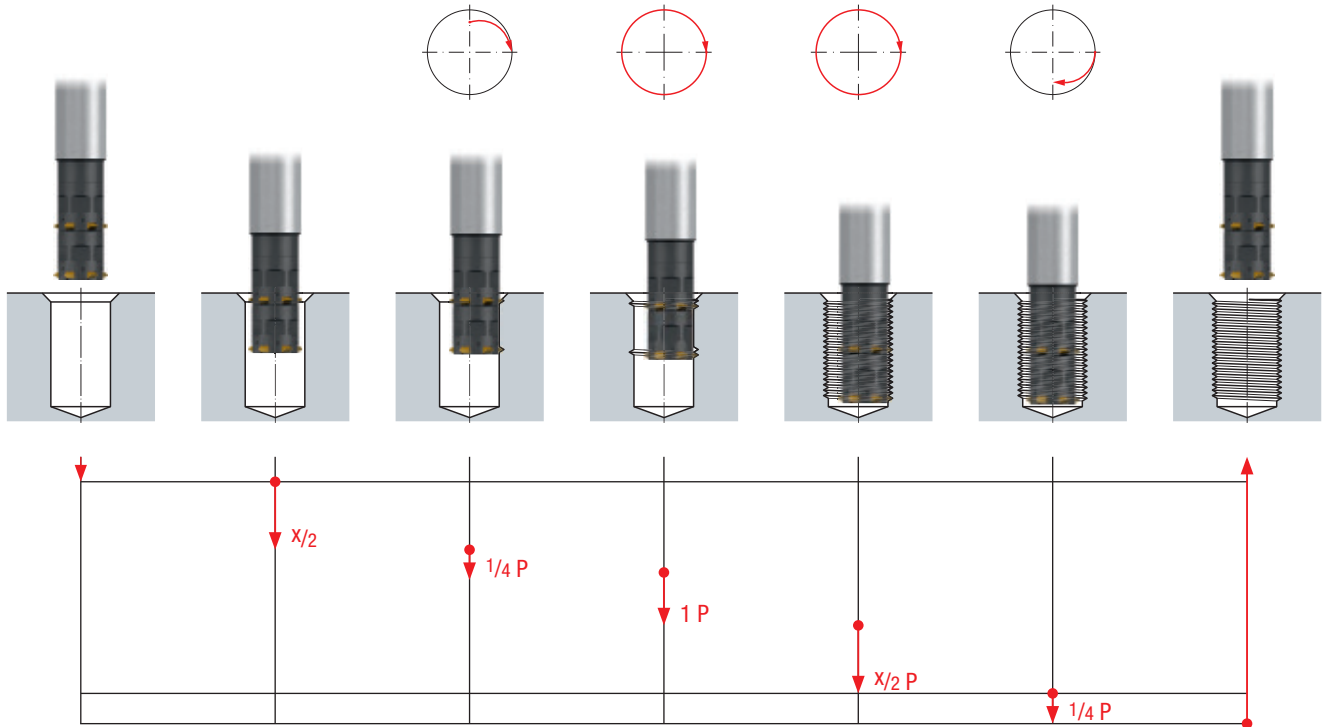

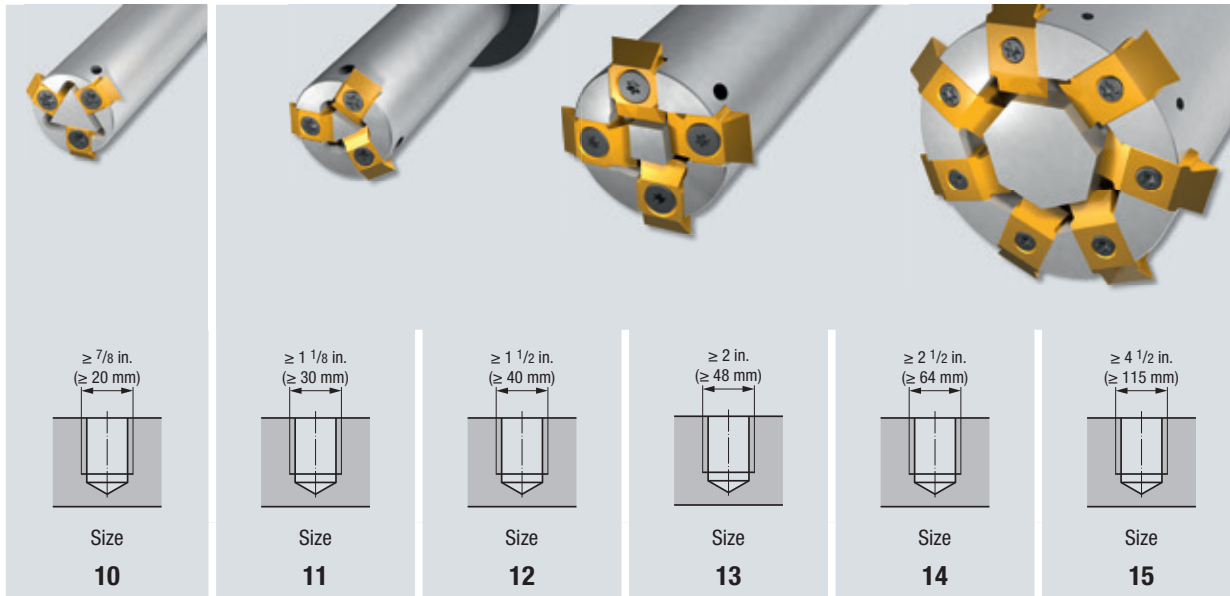

Page					
320	322	324	326, 328	330	332

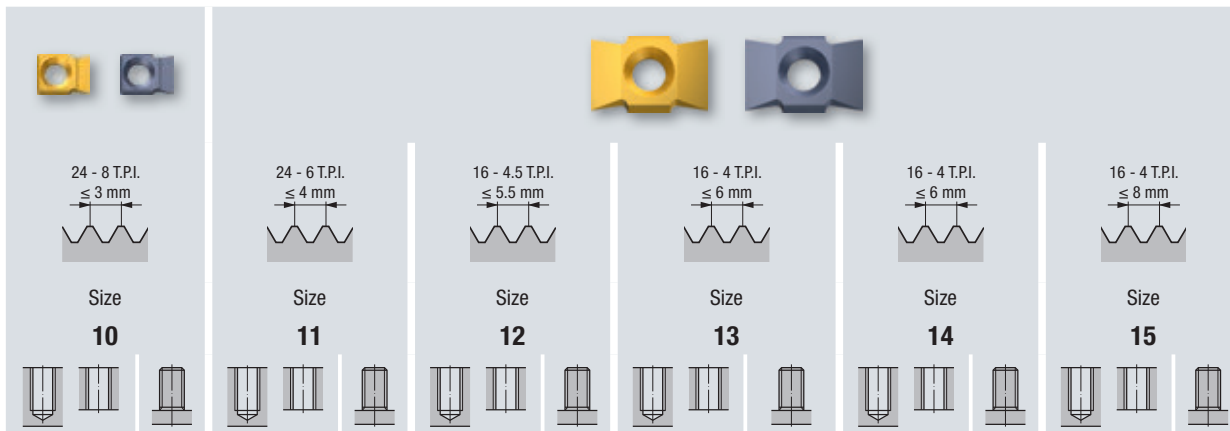

Page										
321		323		325		327, 329		331		333
321	321	323	323	325	325	327, 329	327, 329	331	331	333
321	321	323	323	325	325	327, 329	327, 329	331	331	
		323		325						

	Milling rings for removal of the incomplete thread	Page 334
	Holders for Gigant	336 - 337

Need programming assistance?

EMUGE's trained thread milling specialist can assist you with advice and guidance in writing the correct program for your CNC machine tool. Thread milling experts will analyze your exact application and help guide you through the proper line code programming.

Contact EMUGE Technical Support department or visit www.emuge.com

Product Finder

v_c / f_z

UNC

UNF

UN

M

MF

NPSF

Rp (BSPP)

G

W

BSW, BSF

NPT

NPTF

Rc (BSPT)

STI

SELF-LOCK

Accessories

Tech. Info

BGF

ZBGF

GSF (Aero)

GSF-Z

GF(I), GF-Z

GF-Vario-Z

GF-H

GF(I)-KEG

ZGF(I)

CIRC-GF

Gigant

FPC, FMC

MoSys

G (BSP), BSW, BSF, W

NPT



- Product Finder
- v_c / f_z
- UNC
- UNF
- UN
- M
- MF
- NPSF
- Rp (BSPP)
- G
- W
- BSW, BSF
- NPT
- NPTF
- Rc (BSPT)
- STI
- SELF-LOCK
- Accessories
- Tech. Info

- BGF
- ZBGF
- GSF (Aero)
- GSF-Z
- GF(I), GF-Z
- GF-Vario-Z
- GF-H
- GF(I)-KEG
- ZGF(I)
- CIRC-GF
- Gigant**
- FPC, FMC
- MoSys

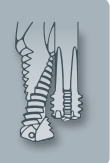

Gigant-ic

Advantages:

- Flexibility

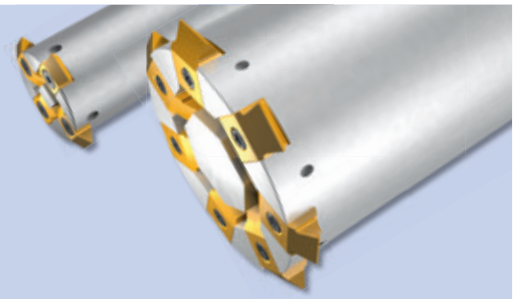

Gigant sprinter

Advantages:

- Fast operation

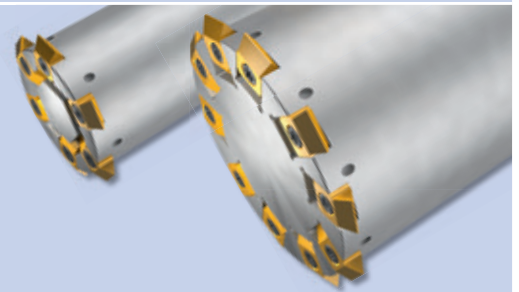

Gigant soft run

Carbide tool body

Advantages:

- Smooth operation
- Stability

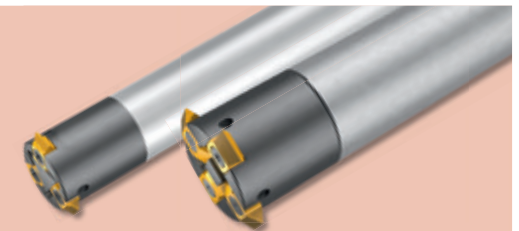

Gigant soft run sprinter

Carbide tool body

Advantages:

- Fast operation
- Smooth operation
- Stability

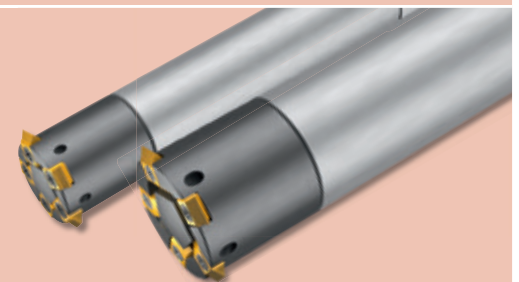

Gigant modular

Advantages:

- Modular construction

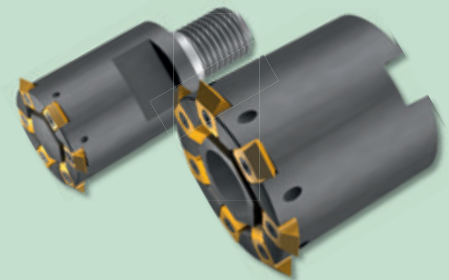

Gigant modular sprinter

Advantages:

- Flexible lengths
- Reduced machining times

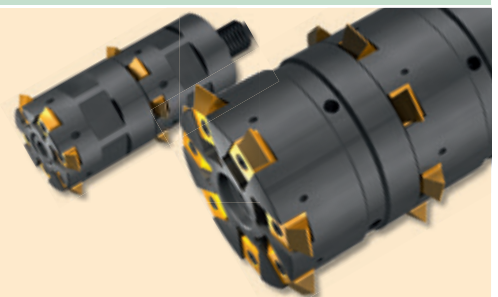

Product Finder

v_c / f_z

UNC

UNF

UN

M

MF

NPSF

Rp (BSPP)

G

W

BSW, BSF

NPT

NPTF

Rc (BSPT)

STI

SELF-LOCK

Accessories

Tech. Info

BGF

ZBGF

GSF (Aero)

GSF-Z

GF(I), GF-Z

GF-Vario-Z

GF-H

GF(I)-KEG

ZGF(I)

CIRC-GF

Gigant

FPC, FMC

MoSys



10

For large thread sizes, from thread diameter 7/8 in. (20 mm)

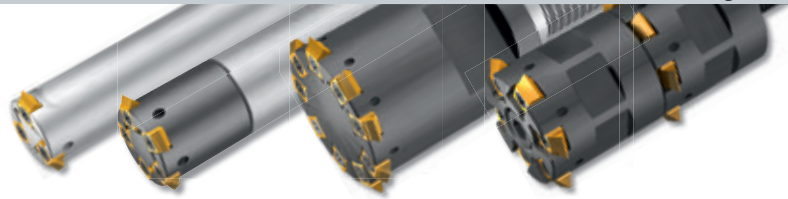

Gigant-ic

ASME B94.19		3 Inserts		2-5 Ins.					
$\varnothing D_{min.}$	l_1	l_3	l_5	$\varnothing d_1$	$\varnothing d_2$	$\varnothing d_5$	Ins.	Gigant-ic Size 10-IKZN	Gigant sprinter Size 10-IKZN
7/8	3.425	1 25/32	1.575	0.669	1/2	0.470	2		GZ340000 ●
1	4.567	1 29/32	2.575	0.807	5/8	0.626	3	GZ340050 ●	GZ340200 ●
1 1/8	5.610	2 9/32	3.150	0.939	1 1/4	0.748	5		

DIN 1835 B		2-3 Ins.		5 Inserts					
$\varnothing D_{min.}$	l_1	l_3	l_5	$\varnothing d_1$	$\varnothing d_2$ h6	$\varnothing d_5$	Ins.	Gigant-ic Size 10-IKZN	Gigant sprinter Size 10-IKZN
20	87	45	40	17	12	12	2	GZ341000 ●	
24	100	48	50	20.5	16	15.9	3	GZ341040 ●	
24	115	48	65	20.5	16	15.9	3	GZ341050 ●	
30	145	60	80	23.85	32	19	5		GZ341200 ●

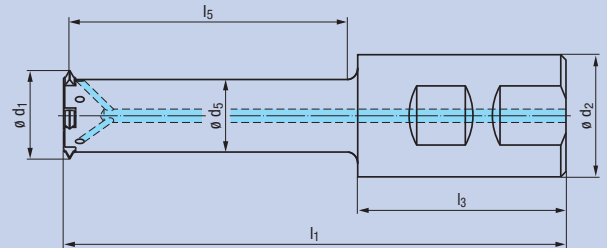

Gigant soft run

DIN 6535 HA		2-3 Ins.		5-8 Ins.					
$\varnothing D_{min.}$	l_1	l_3	l_5	$\varnothing d_1$	$\varnothing d_2$ h6	$\varnothing d_5$	Ins.	Gigant soft run Size 10-IKZN	Gigant soft run sprinter Size 10-IKZN
20	97	45	50	17	12	12	2	GZ34A010 ●	
24	115	48	65	20.5	16	15.9	3	GZ34A000 ●	
30	142	50	90	23.85	20	19	5		GZ34C000 ●
ZGF(I)	36	153	56	95	30	25	7		GZ34C010 ●
40	178	60	115	32.85	32	27.7	8		GZ34C020 ●

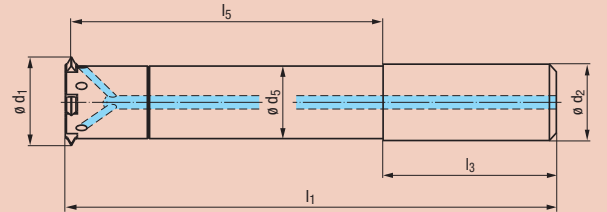

With variable length upon request

Gigant modular

M		9 Inserts					
$\varnothing D_{min.}$	l_6	$\varnothing d_1$	$\varnothing d_5$	G_1	w/f	Ins.	Gigant modular Size 10-IKZN
40	38	34.25	28.8	M16	22	9	GZ351000 ●

Can only be used individually

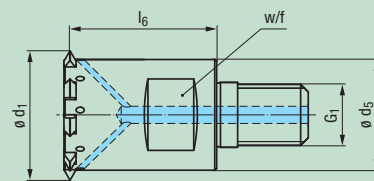

Gigant modular sprinter

MF		6 Inserts					
$\varnothing D_{min.}$	l_7	$\varnothing d_1$	$\varnothing d_5$	G_1	w/f	Ins.	Gigant modular sprinter Size 10-IKZN
32	24	27	22.15	M8 x 1	19	6	GZ353000 ●

Depending on the application, we recommend to combine up to a maximum of 3 Gigant modular sprinter

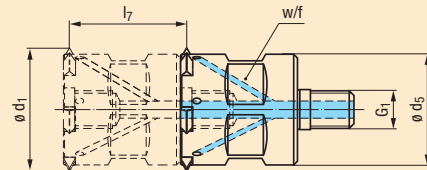

The hexagon socket screw to close the coolant hole on the face side is included with the delivery





The measurement l_7 must be a multiple of the pitch P of the thread to be produced

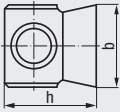

Holders and extensions for Gigant modular and Gigant modular sprinter, see pages 336 - 337

10

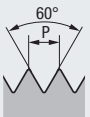
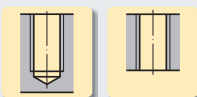
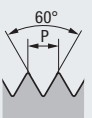
2-tooth indexable inserts for a pitch range from 24 - 8 T.P.I. (up to 3 mm)

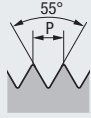
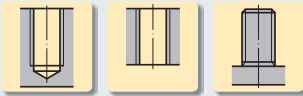
						Carbide		RH + LH							
						Coating				TIN	TIALN-T4				
						Applications – Material		P 1.1-5.1 M 1.1-4.1 K 1.1-4.2 N 1.1-4.4 S 1.1-3							
T.P.I.	P mm	b mm	inch	h mm	inch	HM-WP-Z2 Size 10 TIN		HM-WP-Z2 Size 10 TIALN-T4							
<h2>UN, M, MF</h2> <p>Unified threads ANSI B1.1 and ISO Metric threads DIN 13</p>  <p>For internal threads</p> 						24 - 10	1 - 2.5	5	0.197	7	0.276	GF643005.9512	●	GF643007.9512	●
16 - 8	1.5 - 3	5	0.197	7	0.276	GF643005.9514	●	GF643007.9514	●						
<h2>M, MF</h2> <p>ISO Metric threads DIN 13</p>  <p>For external threads</p> 						1.5	5	0.197	7	0.276			GF641007.9514	●	
	2	5	0.197	7	0.276			GF641007.9516	●						
<h2>G (BSP), BSW, BSF, W</h2> <p>Whitworth pipe threads DIN EN ISO 228 and Whitworth threads BS 84</p>  <p>For internal and external threads</p> 						14 (28 - 9)	(1.814)	5	0.197	7	0.276	GF643005.9548	●	GF643007.9548	●

- Product Finder
- v_c / f_z
- UNC
- UNF
- UN
- M
- MF
- NPSF
- Rp (BSPP)
- G
- W
- BSW, BSF
- NPT
- NPTF
- Rc (BSPT)
- STI
- SELF-LOCK
- Accessories
- Tech. Info
- BGF
- ZBGF
- GSF (Aero)
- GSF-Z
- GF(I), GF-Z
- GF-Vario-Z
- GF-H
- GF(I)-KEG
- ZGF(I)
- CIRC-GF
- Gigant
- FPC, FMC
- MoSys

Other designs upon request, e.g.



ACME thread



Round thread



Buttress thread



Infeed inserts in various designs

Accessories

-  Spare screw M2.5 x 8.5; Torx T7 } **GZ349010**
-  Screw driver Torx T7 } **GZ349020**
-  Torque screw driver Torx T7 } **GZ349040**
-  Screw plug M8x1 x 10; w/f 4 } **GZ359310**





● = In stock
★ = Allow 7 days for delivery

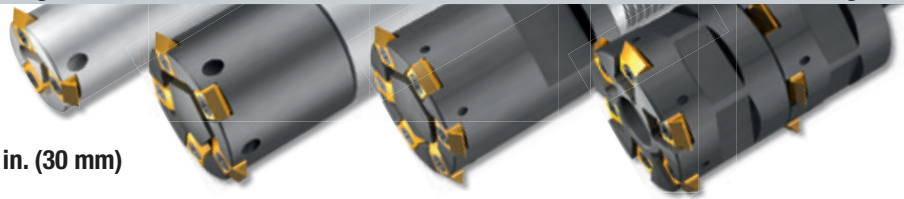



11

For large thread sizes, from thread diameter 1 1/8 in. (30 mm)





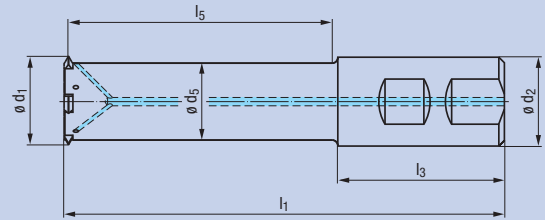

Gigant-ic Gigant sprinter

ASME B94.19		3-5 Ins.	6-8 Ins.						
									
$\varnothing D_{min.}$	l_1	l_3	l_5	$\varnothing d_1$	$\varnothing d_2$	$\varnothing d_5$	Ins.	Gigant-ic Size 11-IKZN	Gigant sprinter Size 11-IKZN
1 1/8	4.744	2 9/32	2.362	0.939	1 1/4	0.748	3	GZ340121 ●	
1 1/8	5.512	2 9/32	3.150	0.939	1 1/4	0.748	3	GZ340001 ●	
1 1/8	5.906	2 9/32	3.543	0.939	1 1/4	0.748	3	GZ340101 ●	
1 1/2	5.945	2 9/32	3.543	1.102	1 1/4	0.906	5	GZ340211 ●	
1 1/2	6.244	2 9/32	3.740	1.293	1 1/4	1.091	5	GZ340201 ●	
1 3/4	4.799	2 9/32	2.398	1.339	1 1/4	1.134	6		GZ340221 ●
2	5.591	2 9/32	3.150	1.585	1 1/4	1.378	8		GZ340231 ●

DIN 1835 B		3 Inserts	5-8 Ins.						
									
$\varnothing D_{min.}$	l_1	l_3	l_5	$\varnothing d_1$	$\varnothing d_2$ h6	$\varnothing d_5$	Ins.	Gigant-ic Size 11-IKZN	Gigant sprinter Size 11-IKZN
30	122	60	60	23.85	32	19	3	GZ341121 ●	
30	138	56	80	23.85	25	19	3	GZ341021 ●	
30	142	60	80	23.85	32	19	3	GZ341001 ●	
30	152	60	90	23.85	32	19	3	GZ341101 ●	
34	153	60	90	28	32	23	5		GZ341211 ●
36	157	60	95	29.5	32	24.5	3	GZ341131 ●	
40	159	60	95	32.85	32	27.7	5		GZ341201 ●
40	124	60	60	34	32	28.8	6		GZ341221 ●
48	144	60	80	40.25	32	35	8		GZ341231 ●





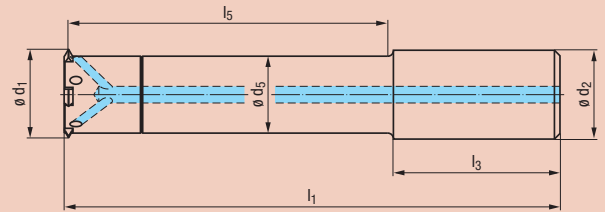

Gigant soft run Gigant soft run sprinter

DIN 6535 HA		3 Inserts	5 Inserts						
									
$\varnothing D_{min.}$	l_1	l_3	l_5	$\varnothing d_1$	$\varnothing d_2$ h6	$\varnothing d_5$	Ins.	Gigant soft run Size 11-IKZN	Gigant soft run sprinter Size 11-IKZN
30	142	50	90	23.85	20	19	3	GZ34A001 ●	
40	179	60	115	32.85	32	27.7	5		GZ34C001 ●



With variable length upon request



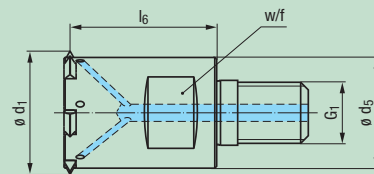

Gigant modular

M		6 Inserts					
							
$\varnothing D_{min.}$	l_6	$\varnothing d_1$	$\varnothing d_5$	G_1	w/f	Ins.	Gigant modular Size 11-IKZN
42	38	34.25	28.8	M16	22	6	GZ351001 ●

Can only be used individually



Gigant modular sprinter

MF		6 Inserts					
							
$\varnothing D_{min.}$	l_7	$\varnothing d_1$	$\varnothing d_5$	G_1	w/f	Ins.	Gigant modular sprinter Size 11-IKZN
42	24	34.25	29.15	M10 x 1	25	6	GZ353001 ●

Depending on the application, we recommend to combine up to a maximum of 3 Gigant modular sprinter

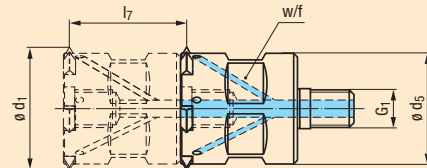

The hexagon socket screw to close the coolant hole on the face side is included with the delivery

The measurement l_7 must be a multiple of the pitch P of the thread to be produced

11

4-tooth indexable inserts for a pitch range from 24 - 6 T.P.I. (up to 4 mm)

						Carbide RH + LH			
						Coating: TIN TIALN-T4			
						Applications – Material: P 1.1-5.1 M 1.1-4.1 K 1.1-4.2 N 1.1-4.4 S 1.1-3			
T.P.I.	P mm	b mm	inch	h mm	inch	HM-WP-Z4 Size 11 TIN		HM-WP-Z4 Size 11 TIALN-T4	

<h2>UN, M, MF</h2> <p>Unified threads ANSI B1.1 and ISO Metric threads DIN 13</p> <p>For internal threads</p>									
24 - 10	1 - 2.5	6.35	0.250	9.52	0.375	GF643105.9512	●	GF643107.9512	●
16 - 10	1.5 - 2.5	6.35	0.250	9.52	0.375	GF643105.9514	●	GF643107.9514	●
10 - 6	2.5 - 4	6.35	0.250	9.52	0.375	GF643105.9517	●	GF643107.9517	●

<h2>M, MF</h2> <p>ISO Metric threads DIN 13</p> <p>For external threads</p>									
	2.5	6.35	0.250	9.52	0.375			GF641107.9517	●
	3	6.35	0.250	9.52	0.375			GF641107.9518	●

<h2>G (BSP), BSW, BSF, W</h2> <p>Whitworth pipe threads DIN EN ISO 228 and Whitworth threads BS 84</p> <p>For internal and external threads</p>									
11 (28 - 9)	(2.309)	6.35	0.250	9.52	0.375	GF643105.9550	●	GF643107.9550	●

<h2>NPT</h2> <p>American tapered pipe thread, ANSI/ASME B1.20.1 for threads with dryseal material, taper 1:16</p> <p>For internal threads</p>									
11 1/2	(2.209)	6.35	0.250	9.52	0.375			GF643107.9679	●

Milling rings for removal of the incomplete thread, see page 334

Holders and extensions for Gigant modular and Gigant modular sprinter, see pages 336 - 337

Other designs upon request, e.g.



Accessories

- Spare screw M2.5 x 8.5; Torx T7 } **GZ349011**
- Screw driver Torx T7 } **GZ349021**
- Torque screw driver Torx T7 } **GZ349041**
- Screw plug M10x1 x 12; w/f 5 } **GZ359311**

● = In stock
★ = Allow 7 days for delivery

- Product Finder
- v_c / f_z
- UNC
- UNF
- UN
- M
- MF
- NPSF
- Rp (BSPP)
- G
- W
- BSW, BSF
- NPT
- NTF
- Rc (BSPT)
- STI
- SELF-LOCK
- Accessories
- Tech. Info
- BGF
- ZBGF
- GSF (Aero)
- GSF-Z
- GF(I), GF-Z
- GF-Vario-Z
- GF-H
- GF(I)-KEG
- ZGF(I)
- CIRC-GF
- Gigant
- FPC, FMC
- MoSys



12

For large thread sizes, from thread diameter 1 1/2 in. (40 mm)



Gigant-ic

ASME B94.19   

inch								Gigant-ic	Gigant sprinter
Ø D _{min.}	l ₁	l ₃	l ₅	Ø d ₁	Ø d ₂	Ø d ₅	Ins.	Size 12-IKZN	Size 12-IKZN
1 1/2	6.102	2 9/32	3.740	1.293	1 1/4	0.965	3	GZ340012 ●	
1 1/2	6.890	2 9/32	4.528	1.293	1 1/4	0.965	3	GZ340112 ●	
1 3/4	7.555	2 9/32	5.118	1.417	1 1/4	1.094	4		GZ340212 ●
2	6.772	2 9/32	4.331	1.585	1 1/4	1.256	5		GZ340202 ●

DIN 1835 B   

mm								Gigant-ic	Gigant sprinter
Ø D _{min.}	l ₁	l ₃	l ₅	Ø d ₁	Ø d ₂ h6	Ø d ₅	Ins.	Size 12-IKZN	Size 12-IKZN
40	153	56	95	32.85	25	24.5	3	GZ341032 ●	
40	158	60	95	32.85	32	24.5	3	GZ341012 ●	
40	178	60	115	32.85	32	24.5	3	GZ341112 ●	
48	172	60	110	40.25	32	31.9	5		GZ341202 ●

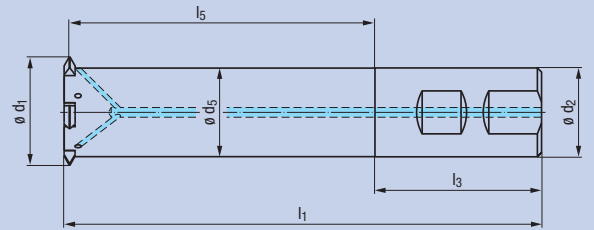

Gigant soft run

DIN 6535 HA   

mm								Gigant soft run	Gigant soft run sprinter
Ø D _{min.}	l ₁	l ₃	l ₅	Ø d ₁	Ø d ₂ h6	Ø d ₅	Ins.	Size 12-IKZN	Size 12-IKZN
40	173	56	115	32.85	25	24.5	3	GZ34A002 ●	
48	207	60	145	40.25	32	31.9	5		GZ34C002 ●

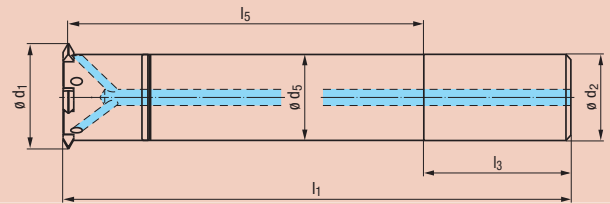

With variable length upon request

Gigant modular

M  

mm							Gigant modular
Ø D _{min.}	l ₆	Ø d ₁	Ø d ₅	G ₁	w/f	Ins.	Size 12-IKZN
46	38	37.5	28.8	M16	22	4	GZ351002 ●

Can only be used individually

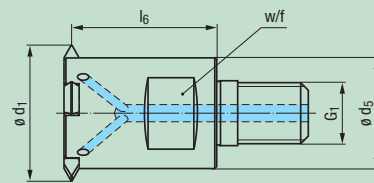

Gigant modular sprinter

MF  

mm							Gigant modular sprinter
new Ø D _{min.}	l ₇	Ø d ₁	Ø d ₅	G ₁	w/f	Ins.	Size 12-IKZN
58	36	46	37.65	M12 x 1	32	6	GZ353002 ●

Depending on the application, we recommend to combine up to a maximum of 3 Gigant modular sprinter

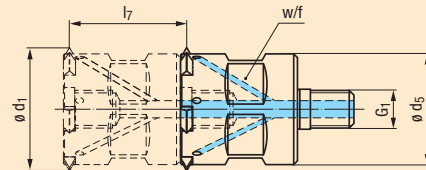

The hexagon socket screw to close the coolant hole on the face side is included with the delivery









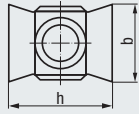

The measurement l₇ must be a multiple of the pitch P of the thread to be produced

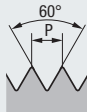
 Milling rings for removal of the incomplete thread, see page 334

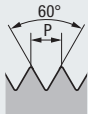
 Holders and extensions for Gigant modular and Gigant modular sprinter, see pages 336 - 337

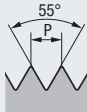
12

4-tooth indexable inserts for a pitch range from 16 - 4.5 T.P.I. (up to 5.5 mm)

						Carbide RH + LH		 	
						Coating		Applications – Material	
						TIN		TIALN-T4	
						P 1.1-5.1 M 1.1-4.1 K 1.1-4.2 N 1.1-4.4 S 1.1-3			
T.P.I.	P mm	b mm	inch	h mm	inch	HM-WP-Z4 Size 12 TIN		HM-WP-Z4 Size 12 TIALN-T4	
<h2>UN, M, MF</h2> <p>Unified threads ANSI B1.1 and ISO Metric threads DIN 13</p>  <p>For internal threads</p> 						GF643205.9514 ● GF643205.9517 ●		GF643207.9514 ● GF643207.9517 ●	
16 - 10	1.5 - 2.5	8.5	0.335	13.5	0.531				
10 - 4.5	2.5 - 5.5	8.5	0.335	13.5	0.531				
<h2>M, MF</h2> <p>ISO Metric threads DIN 13</p>  <p>For external threads</p> 								GF641207.9519 ● GF641207.9520 ●	
	3.5	8.5	0.335	13.5	0.531				
	4	8.5	0.335	13.5	0.531				
<h2>G (BSP), BSW, BSF, W</h2> <p>Whitworth pipe threads DIN EN ISO 228 and Whitworth threads BS 84</p>  <p>For internal and external threads</p> 						GF643205.9550 ●		GF643207.9550 ●	
11 (28 - 5)	(2.309)	8.5	0.335	13.5	0.531				
<h2>NPT</h2> <p>American tapered pipe thread, ANSI/ASME B1.20.1 for threads with dryseal material, taper 1:16</p>  <p>For internal threads</p> 								GF643207.9680 ●	
8	(3.175)	8.5	0.335	13.5	0.531				

Other designs upon request, e.g.



Accessories

-  Spare screw M3 x 11; Torx T9 } **GZ349012**
-  Screw driver Torx T9 } **GZ349022**
-  Torque screw driver Torx T9 } **GZ349042**
-  Screw plug M12x1 x 16; w/f 6 } **GZ359312**

● = In stock
★ = Allow 7 days for delivery

Product Finder

v_c / f_z

UNC

UNF

UN

M

MF

NPSF

Rp (BSPP)

G

W

BSW, BSF

NPT

NPTF

Rc (BSPT)

STI

SELF-LOCK

Accessories

Tech. Info

BGF

ZBGF

GSF (Aero)

GSF-Z

GF(I), GF-Z

GF-Vario-Z

GF-H

GF(I)-KEG

ZGF(I)

CIRC-GF

Gigant

FPC, FMC

MoSys

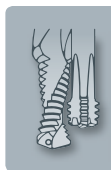

13

For large thread sizes, from thread diameter 2 in. (48 mm)

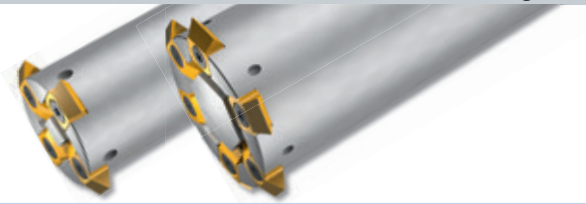

Gigant-ic										Gigant sprinter			
ASME B94.19			4 Inserts		5 Inserts								
$\emptyset D_{min.}$	l_1	l_3	inch		$\emptyset d_1$	$\emptyset d_2$	$\emptyset d_5$	Ins.	Gigant-ic	Gigant sprinter			
			Size 13-IKZN		Size 13-IKZN				Size 13-IKZN				
2	6.732	2 9/32	4.331	1.585	1 1/4	1.220	4	GZ340153	●				
2	8.110	2 9/32	5.709	1.585	1 1/4	1.220	4	GZ340143	●				
2 1/4	9.559	2 11/16	6.693	1.890	1 1/2	1.496	5			GZ340203	●		
DIN 1835 B			4 Inserts										
$\emptyset D_{min.}$	l_1	l_3	mm		$\emptyset d_1$	$\emptyset d_2$	$\emptyset d_5$	Ins.	Gigant-ic				
			Size 13-IKZN		Size 13-IKZN				Size 13-IKZN				
48	173	60	110	40.25	32	31	4	GZ341153	●				
48	208	60	145	40.25	32	31	4	GZ341143	●				
DIN 69871			4 Inserts		6 Inserts								
$\emptyset D_{min.}$	l_1	l_5	$\emptyset d_1$	Taper Size	$\emptyset d_5$	Ins.	Gigant-ic	Gigant sprinter					
			Size 13-IKZN		Size 13-IKZN			Size 13-IKZN					
48	212	110	40.25	SK 40	31	4	GZ343003	●					
48	245	110	40.25	SK 50	31	4	GZ344003	●					
48	247	145	40.25	SK 40	31	4	GZ343103	●					
48	280	145	40.25	SK 50	31	4	GZ344103	●					
64	333	195	52.55	SK 50	43.75	6				GZ344203	●		
ASME B5.50			4 Inserts										
$\emptyset D_{min.}$	l_1	l_5	$\emptyset d_1$	Taper Size	$\emptyset d_5$	Ins.	Gigant-ic						
			Size 13-IKZN		Size 13-IKZN			Size 13-IKZN					
2	9.620	4.331	1.585	CAT 50	1.220	4	GZ346013	●					
2	11.000	5.709	1.585	CAT 50	1.220	4	GZ346003	●					
JIS B 6339			4 Inserts										
$\emptyset D_{min.}$	l_1	l_5	$\emptyset d_1$	Taper Size	$\emptyset d_5$	Ins.	Gigant-ic						
			Size 13-IKZN		Size 13-IKZN			Size 13-IKZN					
2	11.772	5.709	1.585	BT 50	1.220	4	GZ348103	●					

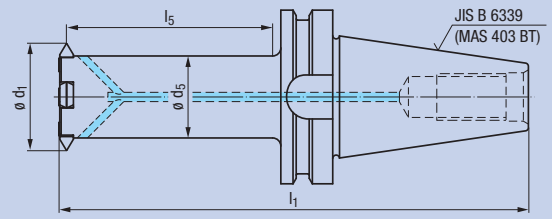
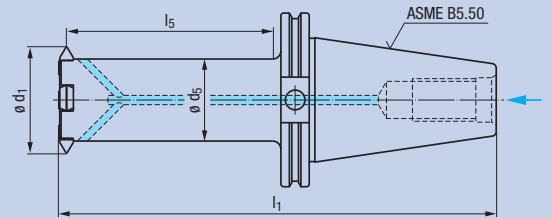
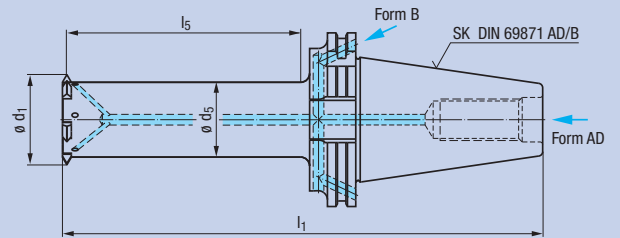
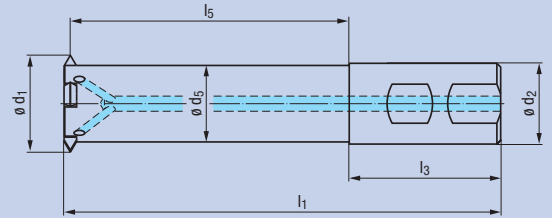





Milling rings for removal of the incomplete thread, see page 334

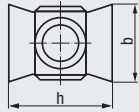

Holders and extensions for Gigant modular and Gigant modular sprinter, see pages 336 - 337

13

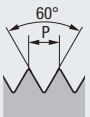
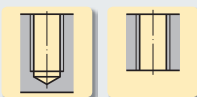
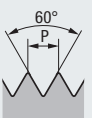
4-tooth indexable inserts for a pitch range from 16 - 4 T.P.I. (up to 6 mm)

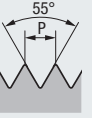
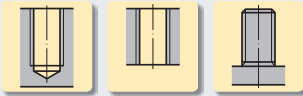

						Carbide RH + LH									
						Coating		TIN		TIALN-T4					
						Applications – Material		P 1.1-5.1 M 1.1-4.1 K 1.1-4.2 N 1.1-4.4 S 1.1-3							
T.P.I.		P		b		h		HM-WP-Z4		HM-WP-Z4					
		mm		mm inch		mm inch		Size 13		Size 13					
								TIN		TIALN-T4					
<h2>UN, M, MF</h2> Unified threads ANSI B1.1 and ISO Metric threads DIN 13 						For internal threads 									
16 - 9		1.5 - 3		9.5 0.374		15.5 0.610		GF643305.9514		●					
9 - 4		3 - 6		9.5 0.374		15.5 0.610		GF643305.9518		●					
<h2>M, MF</h2> ISO Metric threads DIN 13 						For external threads 									
		4.5		9.5 0.374		15.5 0.610				GF641307.9521		●			
		5		9.5 0.374		15.5 0.610				GF641307.9522		●			
<h2>G (BSP), BSW, BSF, W</h2> Whitworth pipe threads DIN EN ISO 228 and Whitworth threads BS 84 						For internal and external threads 									
11 (12 - 4.5)		(2.309)		9.5 0.374		15.5 0.610		GF643305.9550		●		GF643307.9550		●	

- Product Finder
- v_c / f_z
- UNC
- UNF
- UN
- M
- MF
- NPSF
- Rp (BSPP)
- G
- W
- BSW, BSF
- NPT
- NPTF
- Rc (BSPT)
- STI
- SELF-LOCK
- Accessories
- Tech. Info
- BGF
- ZBGF
- GSF (Aero)
- GSF-Z
- GF(I), GF-Z
- GF-Vario-Z
- GF-H
- GF(I)-KEG
- ZGF(I)
- CIRC-GF
- Gigant
- FPC, FMC
- MoSys

Other designs upon request, e.g.



Accessories

-  Spare screw M4 x 13; Torx T15 } GZ349013
-  Screw driver Torx T15 } GZ349023
-  Torque screw driver Torx T15 } GZ349043

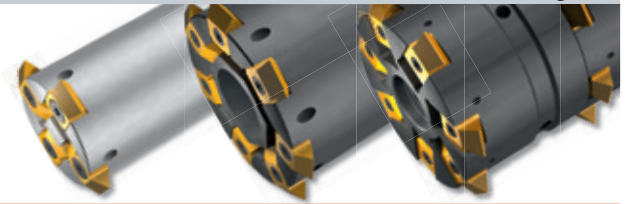

● = In stock
 ★ = Allow 7 days for delivery



13

For large thread sizes, from thread diameter 2 in. (48 mm)

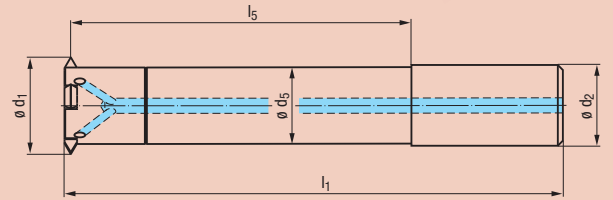

Gigant soft run

DIN 6535 HA			4 Inserts					
$\emptyset D_{min.}$	l_1	l_3	mm l_5	$\emptyset d_1$	$\emptyset d_2$ h6	$\emptyset d_5$	Ins.	Gigant soft run Size 13-IKZN
48	207	60	145	40.25	32	31	4	GZ34A003 ●



With variable length upon request



Gigant modular

DIN 138			7 Inserts			
$\emptyset D_{min.}$	l_6	mm $\emptyset d_1$	$\emptyset d_5$	$\emptyset D_3$	Ins.	Gigant modular Size 13-IKZN
66	47.5	57.5	48	27	7	GZ352003 ●

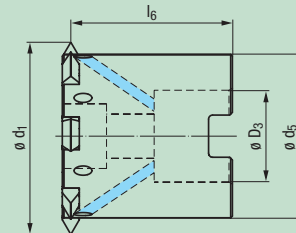
Can only be used individually



Gigant modular sprinter

MF			7 Inserts				
new	$\emptyset D_{min.}$	l_7	mm $\emptyset d_1$	$\emptyset d_5$	G_1	Ins.	Gigant modular sprinter Size 13-IKZN
	66	48	57.5	48	M18 x 1.5	7	GZ353003 ●

The measurement l_7 must be a multiple of the pitch P of the thread to be produced

Depending on the application, we recommend to combine up to a maximum of 3 Gigant modular sprinter

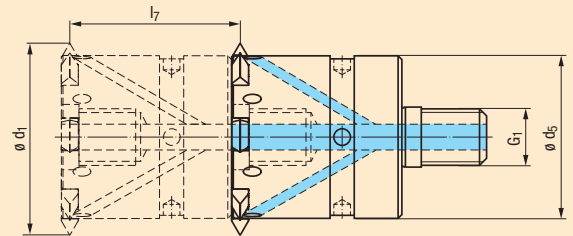







The hexagon socket screw to close the coolant hole on the face side is included with the delivery

 Milling rings for removal of the incomplete thread, see page 334

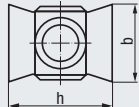
 Holders and extensions for Gigant modular and Gigant modular sprinter, see pages 336 - 337

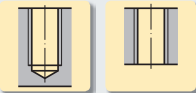
13



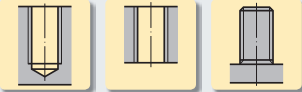

4-tooth indexable inserts for a pitch range from 16 - 4 T.P.I. (up to 6 mm)

						Carbide RH + LH			
						Coating: TIN TIALN-T4			
						Applications – Material: P 1.1-5.1 M 1.1-4.1 K 1.1-4.2 N 1.1-4.4 S 1.1-3			
T.P.I.	P	b	h			HM-WP-Z4	HM-WP-Z4		
	mm	mm	inch	mm	inch	Size 13	Size 13		
						TIN	TIALN-T4		
<h2>UN, M, MF</h2> <p>Unified threads ANSI B1.1 and ISO Metric threads DIN 13</p>  <p>For internal threads</p> 									
16 - 9	1.5 - 3	9.5	0.374	15.5	0.610	GF643305.9514	●	GF643307.9514	●
9 - 4	3 - 6	9.5	0.374	15.5	0.610	GF643305.9518	●	GF643307.9518	●
<h2>M, MF</h2> <p>ISO Metric threads DIN 13</p>  <p>For external threads</p> 									
	4.5	9.5	0.374	15.5	0.610			GF641307.9521	●
	5	9.5	0.374	15.5	0.610			GF641307.9522	●
<h2>G (BSP), BSW, BSF, W</h2> <p>Whitworth pipe threads DIN EN ISO 228 and Whitworth threads BS 84</p>  <p>For internal and external threads</p> 									
11 (12 - 4.5)	(2.309)	9.5	0.374	15.5	0.610	GF643305.9550	●	GF643307.9550	●

Other designs upon request, e.g.



Accessories

-  Spare screw M4 x 13; Torx T15 } **GZ349013**
-  Screw driver Torx T15 } **GZ349023**
-  Torque screw driver Torx T15 } **GZ349043**
-  Hook wrench type B with pin acc. to DIN 1810-B 45-50 mm } **GZ349053**
-  Screw plug M18x1.5 x 20; w/f 10 } **GZ359313**

● = In stock
★ = Allow 7 days for delivery

Product Finder
v _c / f _z
UNC
UNF
UN
M
MF
NPSF
Rp (BSPP)
G
W
BSW, BSF
NPT
NPTF
Rc (BSPT)
STI
SELF-LOCK
Accessories
Tech. Info
BGF
ZBGF
GSF (Aero)
GSF-Z
GF(I), GF-Z
GF-Vario-Z
GF-H
GF(I)-KEG
ZGF(I)
CIRC-GF
Gigant
FPC, FMC
MoSys

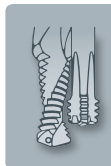

14

For large thread sizes, from thread diameter 2 1/2 in. (64 mm)

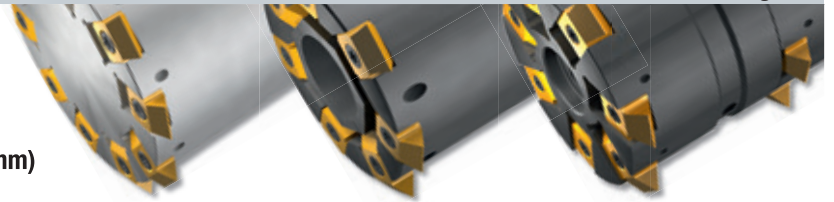

Gigant-ic Gigant sprinter

DIN 69871		4-7 Ins.		Z10				
$\varnothing D_{min.}$	l_1	l_5	$\varnothing d_1$	Taper Size	$\varnothing d_5$	Ins.	Gigant-ic Size 14-IKZN	Gigant sprinter Size 14-IKZN
64	253	150	52.55	SK 40	41	4	GZ343014 ●	
64	286	150	52.55	SK 50	41	4	GZ344014 ●	
64	298	195	52.55	SK 40	41	4	GZ343114 ●	
64	331	195	52.55	SK 50	41	4	GZ344114 ●	
80	308	170	66.55	SK 50	55	7	GZ344024 ●	
80	398	260	66.55	SK 50	55	7	GZ344124 ●	
115	489	360	92	SK 50	80	10		GZ344204 ●

ASME B5.50		4 Inserts					
$\varnothing D_{min.}$	l_1	l_5	$\varnothing d_1$	Taper Size	$\varnothing d_5$	Ins.	Gigant-ic Size 14-IKZN
2 1/2	13.000	7.677	2.069	CAT 50	1.614	4	GZ346024 ●

JIS B 6339		4 Inserts					
$\varnothing D_{min.}$	l_1	l_5	$\varnothing d_1$	Taper Size	$\varnothing d_5$	Ins.	Gigant-ic Size 14-IKZN
2 1/2	13.780	7.677	2.069	BT 50	1.614	4	GZ348114 ●

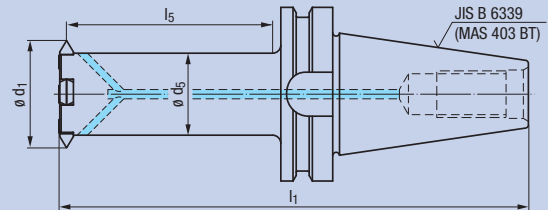
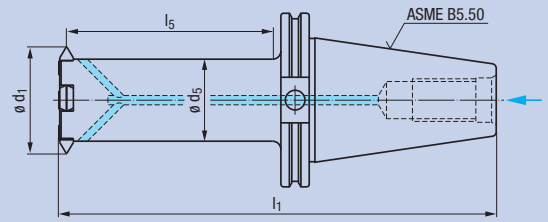
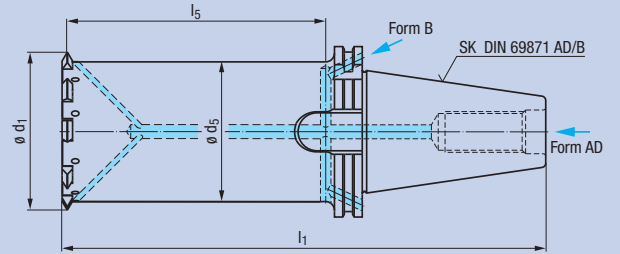

Gigant modular

DIN 138		7 Inserts				
$\varnothing D_{min.}$	l_6	$\varnothing d_1$	$\varnothing d_5$	$\varnothing D_3$	Ins.	Gigant modular Size 14-IKZN
80	47	71.5	60	27	7	GZ352004 ●

Can only be used individually

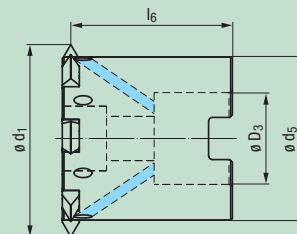

Gigant modular sprinter

MF		7 Inserts				
$\varnothing D_{min.}$	l_7	$\varnothing d_1$	$\varnothing d_5$	G_1	Ins.	Gigant modular sprinter Size 14-IKZN
80	60	71.5	60	M24 x 1.5	7	GZ353004 ●

Depending on the application, we recommend to combine up to a maximum of 3 Gigant modular sprinter

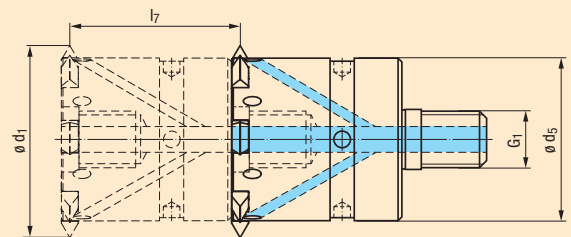

The hexagon socket screw to close the coolant hole on the face side is included with the delivery

The measurement l_7 must be a multiple of the pitch P of the thread to be produced





Milling rings for removal of the incomplete thread, see page 334

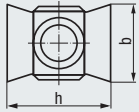
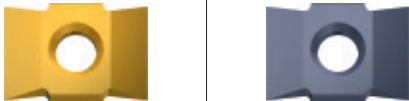

Holders and extensions for Gigant modular and Gigant modular sprinter, see pages 336 - 337

14

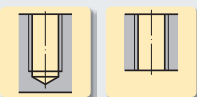
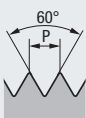
4-tooth indexable inserts for a pitch range from 16 - 4 T.P.I. (up to 6 mm)

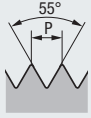
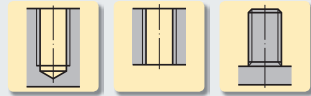
						Carbide RH + LH				
						Coating: TIN TIALN-T4				
						Applications – Material: P 1.1-5.1 M 1.1-4.1 K 1.1-4.2 N 1.1-4.4 S 1.1-3				
T.P.I.	P	b	h			HM-WP-Z4	HM-WP-Z4			
	mm	mm inch	mm inch			Size 14	Size 14			
						TIN	TIALN-T4			
<h2>UN, M, MF</h2> <p>Unified threads ANSI B1.1 and ISO Metric threads DIN 13</p> 						For internal threads				
16 - 9	1.5 - 3	12.5	0.492	19	0.748	GF643405.9514	●	GF643407.9514	●	
9 - 4	3 - 6	12.5	0.492	19	0.748	GF643405.9518	●	GF643407.9518	●	
<h2>M, MF</h2> <p>ISO Metric threads DIN 13</p> 						For external threads				
	5.5	12.5	0.492	19	0.748			GF641407.9709	●	
	6	12.5	0.492	19	0.748			GF641407.9523	●	
<h2>G (BSP), BSW, BSF, W</h2> <p>Whitworth pipe threads DIN EN ISO 228 and Whitworth threads BS 84</p> 						For internal and external threads				
11 (12 - 3.5)	(2.309)	12.5	0.492	19	0.748	GF643405.9550	●	GF643407.9550	●	

Other designs upon request, e.g.

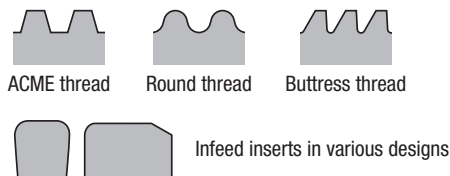

Accessories

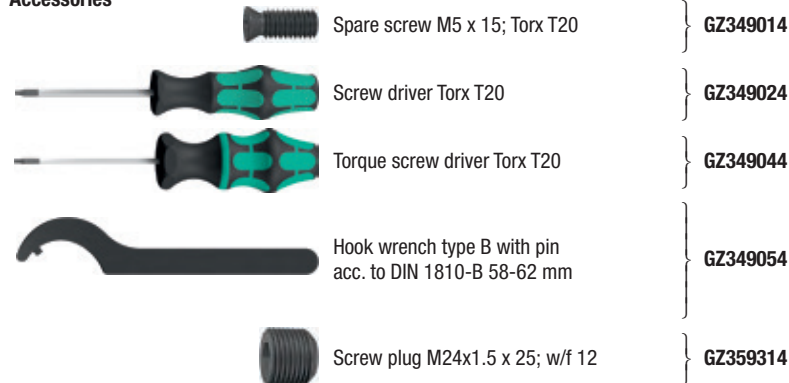

● = In stock
★ = Allow 7 days for delivery

Product Finder

v_c / f_z

UNC

UNF

UN

M

MF

NPSF

Rp (BSPP)

G

W

BSW, BSF

NPT

NPTF

Rc (BSPT)

STI

SELF-LOCK

Accessories

Tech. Info

BGF

ZBGF

GSF (Aero)

GSF-Z

GF(I), GF-Z

GF-Vario-Z

GF-H

GF(I)-KEG

ZGF(I)

CIRC-GF

Gigant

FPC, FMC

MoSys



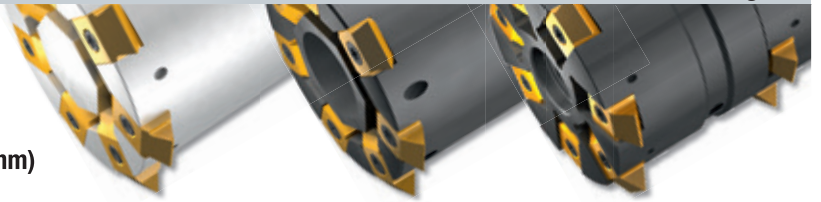

15

For large thread sizes, from thread diameter 4 1/2 in. (115 mm)

Gigant-ic



$\emptyset D_{min.}$	l_1	l_5	mm $\emptyset d_1$	Taper Size	$\emptyset d_5$	Ins.	Gigant-ic Size 15-IKZN
115	341	204	92	SK 50	76	7	GZ344035 ●
115	497	360	92	SK 50	76	7	GZ344045 ●

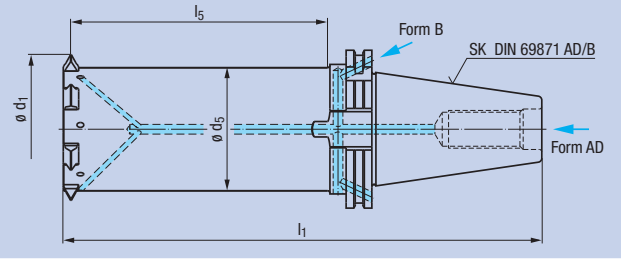

Gigant modular



$\emptyset D_{min.}$	l_6	mm $\emptyset d_1$	$\emptyset d_5$	$\emptyset D_3$	Ins.	Gigant modular Size 15-IKZN
115	55	94	78	32	7	GZ352005 ●

Can only be used individually

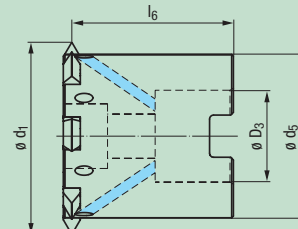

Gigant modular sprinter



new	$\emptyset D_{min.}$	l_7	mm $\emptyset d_1$	$\emptyset d_5$	G_1	Ins.	Gigant modular sprinter Size 15-IKZN
	115	60	94	78	M24 x 1.5	7	GZ353005 ●

The measurement l_7 must be a multiple of the pitch P of the thread to be produced

Depending on the application, we recommend to combine up to a maximum of 3 Gigant modular sprinter

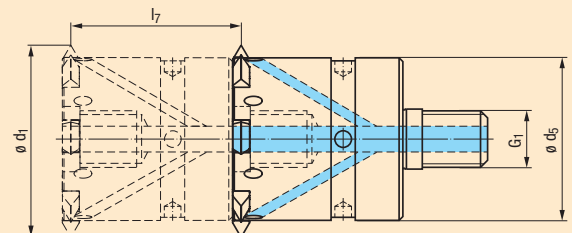



The hexagon socket screw to close the coolant hole on the face side is included with the delivery



Holders and extensions for Gigant modular and Gigant modular sprinter, see pages 336 - 337

15

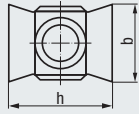
4-tooth indexable inserts for a pitch range from 16 - 4 T.P.I. (up to 8 mm)

		Carbide	RH + LH		
		Coating		TIN	TIALN-T4
		Applications – Material		P 1.1-5.1 M 1.1-4.1 K 1.1-4.2 N 1.1-4.4 S 1.1-3	
T.P.I.	P	b	h	HM-WP-Z4 Size 15 TIN	HM-WP-Z4 Size 15 TIALN-T4
	mm	mm inch	mm inch		

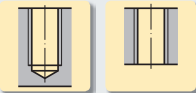
<h2>UN, M, MF</h2> <p>Unified threads ANSI B1.1 and ISO Metric threads DIN 13</p> 		For internal threads 					
16 - 4 4	1.5 - 6 6 - 8	14.3 14.3	0.563 0.563	28.58 28.58	1.125 1.125	GF643505.9514 ● GF643505.9523 ●	GF643507.9514 ● GF643507.9523 ●

Other designs upon request, e.g.



Accessories

-  Spare screw M5 x 18; Torx T20 } **GZ349015**
-  Screw driver Torx T20 } **GZ349025**
-  Torque screw driver Torx T20 } **GZ349045**
-  Hook wrench type B with pin acc. to DIN 1810-B 68-75 mm } **GZ349055**
-  Screw plug M24x1.5 x 25; w/f 12 } **GZ359315**

● = In stock
★ = Allow 7 days for delivery

- Product Finder
- v_c / f_z
- UNC
- UNF
- UN
- M
- MF
- NPSF
- Rp (BSPP)
- G
- W
- BSW, BSF
- NPT
- NPTF
- Rc (BSPT)
- STI
- SELF-LOCK
- Accessories
- Tech. Info
- BGF
- ZBGF
- GSF (Aero)
- GSF-Z
- GF(I), GF-Z
- GF-Vario-Z
- GF-H
- GF(I)-KEG
- ZGF(I)
- CIRC-GF
- Gigant
- FPC, FMC
- MoSys

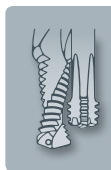

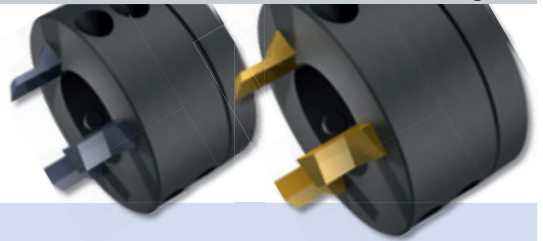

10-14

Milling rings for removal of the incomplete thread

Gigant-ic

3-4 Ins.



new	Size	ø d ₁		ø D ₅ / d ₅		mm			Ins.	
		inch	mm	inch	mm	l ₆	l ₇	ø d ₆		
	10	0.807	20.5	0.626	15.9	18	23	33	3	GZ80FOC4.010040 ●
	11	0.939	23.85	0.748	19	18	22	37	3	GZ80GOC4.011040 ●
	12	1.293	32.85	0.965	24.5	22	24	47	3	GZ80HOC4.012060 ●
	13	1.585	40.25	1.220	31	22	24	55	4	GZ80IOC4.013060 ●
	14	2.069	52.55	1.614	41	22	23	65	4	GZ80JOC4.014060 ●

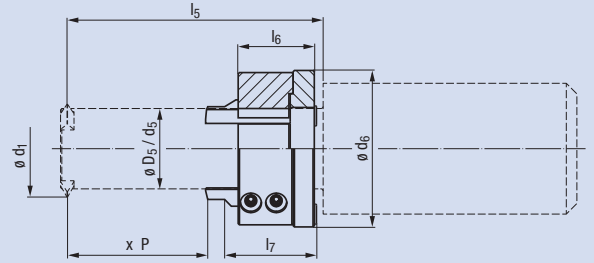

The measurement "x P" must be a multiple of the pitch P of the thread to be produced

The usable depth l₅ of the circular thread milling body is reduced by dimension l₇

1-tooth milling inserts for milling rings



Carbide

RH + LH

new



new



Coating

TIN

TIALN-T4

Applications – Material

P 1.1-5.1 M 1.1-4.1 K 1.1-4.2
N 1.1-4.4 S 1.1-3

Gigant	Size	mm		HM-FP-Z1		HM-FP-Z1	
		l ₈	t	TIN	TIALN-T4		
FPC, FMC	10	20	4	GF663005 ●	GF663007 ●		
MoSys	11	20	4	GF663105 ●	GF663107 ●		
	12	25	6	GF663205 ●	GF663207 ●		
	13	25	6	GF663305 ●	GF663307 ●		
	14	25	6	GF663405 ●	GF663407 ●		



Product
Finder

v_c / f_z

UNC

UNF

UN

M

MF

NPSF

Rp (BSPF)

G

W

BSW, BSF

NPT

NPTF

Rc (BSPT)

STI

SELF-LOCK

Accessories

Tech. Info

BGF

ZBGF

GSF (Aero)

GSF-Z

GF(I), GF-Z

GF-Vario-Z

GF-H

GF(I)-KEG

ZGF(I)

CIRC-GF

Gigant

FPC, FMC

MoSys

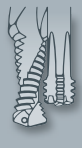

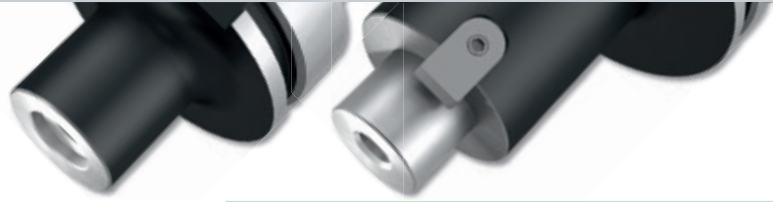

10-15

Holders for Gigant modular

HSK-A

DIN 69893-1

M



Size	G ₁	mm ø d ₅	l ₅	l _A	Taper Size	
10-12	M16	29	29	59	HSK-A63	GZ5391A4.116059 ●

DIN 138



Size	mm ø D ₃	mm ø d ₅	mm l ₅	l ₃	l _A	Taper Size	
13	27	48	131	21	160	HSK-A63	GZ5391B4.270160 ●
14	27	60	131	21	160	HSK-A63	GZ5391B5.270160 ●
15	32	78	171	24	200	HSK-A63	GZ5391B4.320200 ●

SK (ISO)

DIN 69871

M



Size	G ₁	mm ø d ₅	l ₅	l _A	Taper Size	
10-12	M16	29	11	36	SK 40	GZ5243A4.116036 ●
10-12	M16	29	11	36	SK 50	GZ5263A4.116036 ●

DIN 138



Size	mm ø D ₃	mm ø d ₅	mm l ₅	l ₃	l _A	Taper Size	
13	27	48	132	21	160	SK 50	GZ5263B4.270160 ●
14	27	60	132	21	160	SK 50	GZ5263B5.270160 ●
15	32	78	174	24	200	SK 50	GZ5263B4.320200 ●

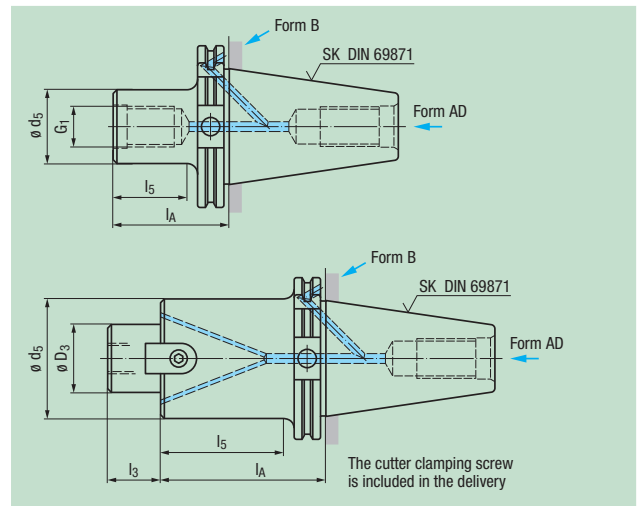
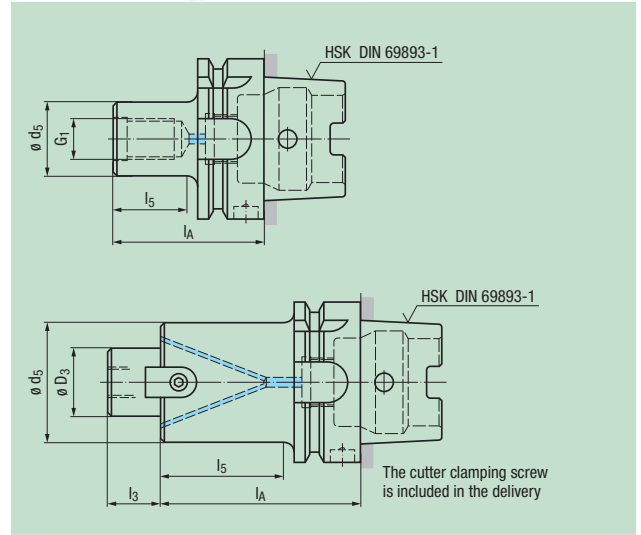

HSS extensions for Gigant modular

32 mm

DIN 1835 A

M



Size	G ₁	mm ø d ₅	mm l ₅	l ₁	mm ø d ₂ h6	
10-12	M16	29.4	108	200	32	GZ5521A4.320108 ●

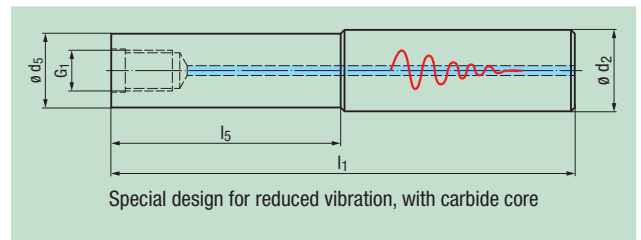

Intermediate adapters for Gigant modular

M16

M



Size	G ₁	mm ø d ₅	mm l _A	w/f	G ₂	
10-12	M16	29	40	22	M16	GZ56E1A4.116040 ●
10-12	M16	29	90	22	M16	GZ56E1A4.116090 ●

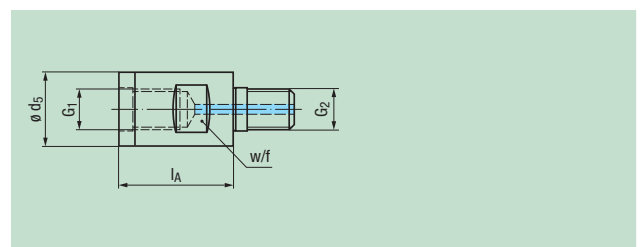

10-15

Holders for Gigant modular sprinter

HSK-A



MF



Size	G ₁	mm		l _A	Taper Size	
		∅ d ₅	l ₅			
10	M 8 x 1	22.15	10	45	HSK-A63	GZ7391AA.251010 ●
11	M10 x 1	29.15	10	45	HSK-A63	GZ7391AB.276010 ●
12	M12 x 1	37.65	12	45	HSK-A63	GZ7391AC.301012 ●
13	M18 x 1.5	48	32	60	HSK-A63	GZ7391AD.390032 ●
14	M24 x 1.5	60	40	80	HSK-A100	GZ73A1AE.452040 ●
15	M24 x 1.5	78	45	76	HSK-A100	GZ73A1AF.452045 ●

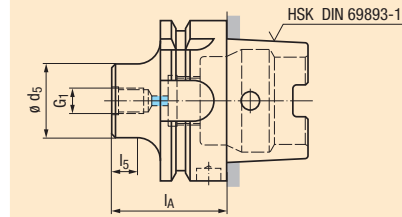

SK (ISO)



MF



Size	G ₁	mm		l _A	Taper Size	
		∅ d ₅	l ₅			
10	M 8 x 1	22.15	10	35	SK 40	GZ7243AA.251010 ●
11	M10 x 1	29.15	10	35	SK 40	GZ7243AB.276010 ●
12	M12 x 1	37.65	12	35	SK 40	GZ7243AC.301012 ●
13	M18 x 1.5	48	15	37	SK 40	GZ7243AD.390015 ●
14	M24 x 1.5	60	15	40	SK 50	GZ7263AE.452015 ●
15	M24 x 1.5	78	20	45	SK 50	GZ7263AF.452020 ●

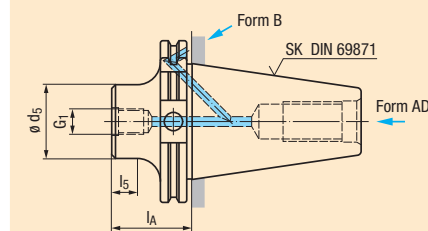

25-32 mm



MF



Size	G ₁	∅ d ₅	mm		∅ d ₂ h6	
			l ₅	l ₁		
10	M 8 x 1	22.15	10	68	25	GZ75D1AA.251010 ●
11	M10 x 1	29.15	10	72	32	GZ7521AB.276010 ●
12	M12 x 1	37.65	12	77	32	GZ7521AC.301012 ●

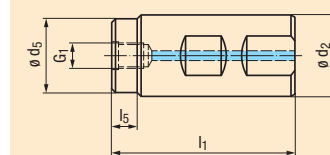

Product Finder

v_c / f_z

UNC

UNF

UN

M

MF

NPSF

Rp (BSPP)

G

W

BSW, BSF

NPT

NPTF

Rc (BSPT)

STI

SELF-LOCK

Accessories

Tech. Info

BGF

ZBGF

GSF (Aero)

GSF-Z

GF(I), GF-Z

GF-Vario-Z

GF-H

GF(I)-KEG

ZGF(I)

CIRC-GF

Gigant

FPC, FMC

MoSys



- Product Finder
- v_c / f_z
- UNC
- UNF
- UN
- M
- MF
- NPSF
- Rp (BSPP)
- G
- W
- BSW, BSF
- NPT
- NPTF
- Rc (BSPT)
- STI
- SELF-LOCK
- Accessories
- Tech. Info
- BGF
- ZBGF
- GSF (Aero)
- GSF-Z
- GF(I), GF-Z
- GF-Vario-Z
- GF-H
- GF(I)-KEG
- ZGF(I)
- CIRC-GF
- Gigant
- FPC, FMC
- MoSys

Introducing the Ultimate Precision Chuck

1. World's only chuck with 1:16 worm gear, a patented design delivering 3 tons of traction force.

2. Optimal pull-out protection via optional Pin-Lock Collet System.

3. High rigidity. Patented design and body provides 100% holding power.



4. Mechanical drive actuated with a hex wrench. Simple design, highly accurate.

5. Maximum dampening. Colletcone assembly absorbs virtually all vibration.

New EMUGE high precision / performance FPC Mill / Thread Mill / Drill Chucks provide unprecedented rigidity, vibration dampening, concentricity, machining speed and tool life vs. conventional chuck technologies for milling and drilling applications. Available in a wide range of styles. Internal and peripheral coolant options, and MQL-adaptable.

Increase your machining speed and tool life to the highest possible levels



EMUGE FPC Chuck Advantages:



- Reliability**
Extremely high transferable torque provides maximum process reliability. Transferred torque on a tool shank diameter of 20 mm is 295 ft lbs / 400 Nm.
- More accurate**
With a 3 x D tool length, concentricity is $\leq 3 \mu\text{m}$, guaranteeing long tool life and quality surface finishes.
- Longer tool life**
Special holder design reduces vibration, dramatically improving work piece surface finishes and providing exceptionally long tool life.
- Fast tool change**
Simple, highly accurate design enables quick tool change in seconds, via hex wrench.

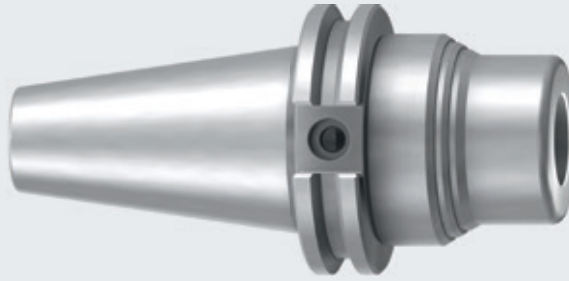

FPC
CAT Shank
ASME B5.50



FPC  

AT3  **G2.5**  20000RPM



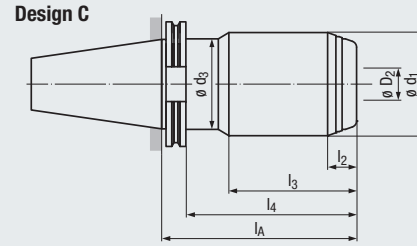
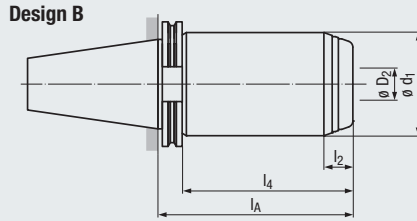
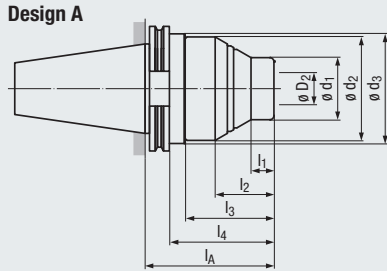

new		inch											EDP Number	
Size	$\varnothing D_2$ inch mm	Shank Size	Design	$\varnothing d_1$	$\varnothing d_2$	$\varnothing d_3$	l_1	l_2	l_3	l_4	l_A			
FPC 14	1/8 - 9/16	2 - 14	CAT 40	A	1.1811	1.9685	—	0.4331	1.1024	—	1.6929	2.4409	6494.401406 *	●
			CAT 40	A	1.1811	1.9685	—	2.4016	3.0709	—	3.6614	4.4094	6494.401411	●
			CAT 40	A	1.1811	1.9685	—	3.3465	4.0551	—	5.0787	5.8268	6494.401414 *	●
			CAT 50	A	1.1811	1.9685	—	0.4331	1.1024	—	1.6929	2.4409	6494.501406	●
			CAT 50	A	1.1811	1.9685	—	3.3465	4.0551	—	5.1181	5.8268	6494.501414	●
			CAT 50	A	1.1811	1.9685	2.7559	3.3465	4.0551	5.1181	5.7087	6.4567	6494.501416	●
FPC 20	1/8 - 3/4	2 - 20	CAT 40	A	1.5748	1.9685	—	0.7874	1.1024	—	1.6929	2.4409	6494.402006 *	●
			CAT 40	A	1.5748	1.9685	—	2.7165	3.0709	—	3.6614	4.4094	6494.402011 *	●
			CAT 40	A	1.5748	1.9685	—	3.7008	4.0551	—	5.0787	5.8661	6494.402014 *	●
			CAT 50	A	1.5748	2.4803	—	0.7087	1.4961	—	1.6929	2.4409	6494.502006	●
			CAT 50	A	1.5748	2.4803	—	3.3071	4.0945	—	5.0787	5.8661	6494.502014	●
			CAT 40	C	2.4803	—	1.9685	0.5512	—	3.2677	2.4016	4.0157	6494.402510 *	●
FPC 25	5/8 - 1 1/4	16 - 32	CAT 50	B	2.7559	—	—	0.5906	—	—	3.2677	4.0157	6494.502510	●

Note: Mechanical drive torque wrench must be set at **max. 7.38 ft lbs / 10 Nm**

 *** Caution: tool does not have a safety zone. Be sure to check for tool changer interference before using.**

Fine balanced design and ultra slim design available upon request

Length stop available upon request

Description of the symbols, see page 348

Accessories



FPC Collets and accessories

» 345 - 348

Product Finder

v_c / f_z

UNC

UNF

UN

M

MF

NPSF

Rp (BSPP)

G

W

BSW, BSF

NPT

NPTF

Rc (BSPT)

STI

SELF-LOCK

Accessories

Tech. Info

BGF

ZBGF

GSF (Aero)

GSF-Z

GF(I), GF-Z

GF-Vario-Z

GF-H

GF(I)-KEG

ZGF(I)

CIRC-GF

Gigant

FPC, FMC

MoSys



FPC

HSK-A Shank

DIN 69893 A

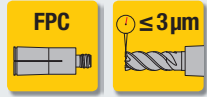
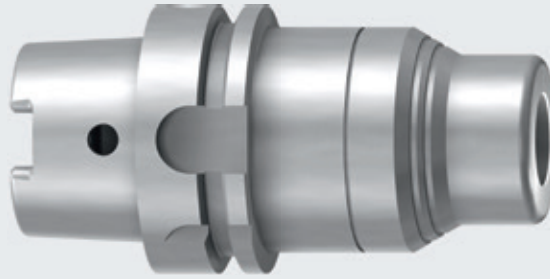

G2.5
20000 RPM

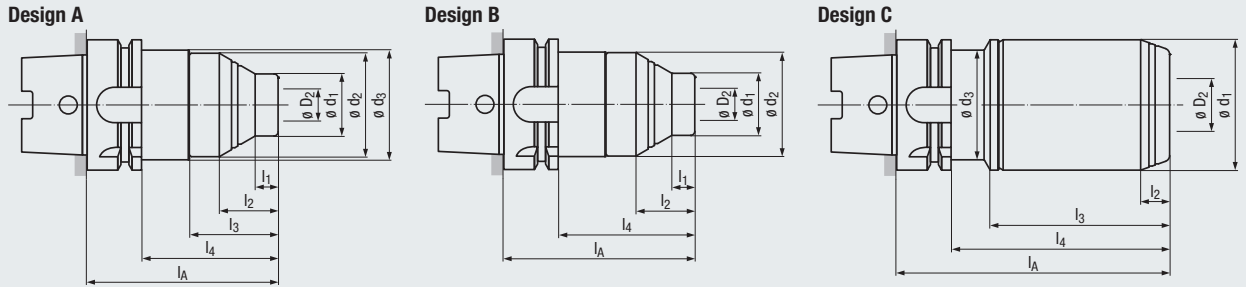

new		mm											EDP Number	
Size	inch	$\varnothing D_2$ mm	Shank Size	Design	$\varnothing d_1$	$\varnothing d_2$	$\varnothing d_3$	l_1	l_2	l_3	l_4	l_A		
FPC 14	1/8 - 9/16	2 - 14	HSK-A50	A	30	50	—	11	28	55	75	101	6492.501410	●
			HSK-A50	A	30	50	—	85	103	141	161	187	6492.501418	●
			HSK-A63	A	30	50	53	11	28	43	66	92	6492.631409	●
			HSK-A63	A	30	50	53	61	78	93	116	142	6492.631414	●
			HSK-A63	A	30	50	53	85	103	129	152	178	6492.631417	●
FPC 20	1/8 - 3/4	2 - 20	HSK-A50	A	40	50	—	20	28	55	75	101	6492.502010	●
			HSK-A63	B	40	53	—	20	31	—	66	92	6492.632009	●
			HSK-A63	B	40	53	—	69	81	—	116	142	6492.632014	●
			HSK-A63	B	40	53	—	94	105	—	152	178	6492.632017	●
			HSK-A80	B	40	63	—	18	38	—	72	98	6492.802009	●
			HSK-A100	A	40	63	70	18	38	43	71	100	6492.102010	●
			HSK-A100	A	40	63	70	48	68	93	121	150	6492.102014	●
FPC 25	5/8 - 1 1/4	16 - 32	HSK-A63	C	63	—	53	—	14	87	106	132	6492.632513	●
			HSK-A80	C	63	—	—	—	14	—	111	137	6492.802513	●
			HSK-A100	C	70	—	—	—	14	—	110	139	6492.102514	●

Note: Mechanical drive torque wrench must be set at **max. 7.38 ft lbs / 10 Nm**

Fine balanced design and ultra slim design available upon request

Length stop available upon request

Description of the symbols, see page 348

Accessories



FPC Collets and accessories

» 345 - 348



Coolant tubes and wrenches

» 606 - 607

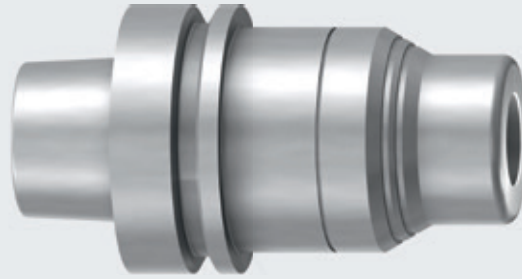

FPC
HSK-F Shank
DIN 69893 F

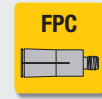

Design B

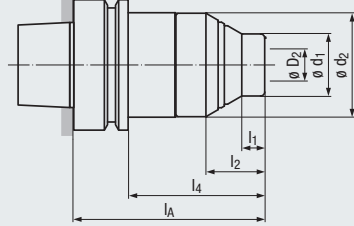

new		mm										EDP Number	●
Size	inch	$\varnothing D_2$ mm	Shank Size	Design	$\varnothing d_1$	$\varnothing d_2$	l_1	l_2	l_4	l_A			
FPC 20	1/8 - 3/4	2 - 20	HSK-F63	B	40	50	20	28.5	66	92	6497.632009	●	

Note: Mechanical drive torque wrench must be set at **max.** 7.38 ft lbs / 10 Nm

Fine balanced design and ultra slim design available upon request

Length stop available upon request

Description of the symbols, see page 348

Accessories



FPC Collets and accessories

» 345 - 348

- Product Finder
- v_c / f_z
- UNC
- UNF
- UN
- M
- MF
- NPSF
- Rp (BSPP)
- G
- W
- BSW, BSF
- NPT
- NPTF
- Rc (BSPT)
- STI
- SELF-LOCK
- Accessories
- Tech. Info
- BGF
- ZBGF
- GSF (Aero)
- GSF-Z
- GF(I), GF-Z
- GF-Vario-Z
- GF-H
- GF(I)-KEG
- ZGF(I)
- CIRC-GF
- Gigant
- FPC, FMC**
- MoSys



- Product Finder
- v_c / f_z
- UNC
- UNF
- UN
- M
- MF
- NPSF
- Rp (BSPP)
- G
- W
- BSW, BSF
- NPT
- NPTF
- Rc (BSPT)
- STI
- SELF-LOCK
- Accessories
- Tech. Info

FPC

SK Shank

DIN ISO 7388-1
(formerly DIN 69871 AD, DIN 69871 B)



FPC

$\leq 3 \mu\text{m}$

AT3

G2.5
20 000 RPM

IKZ

Design A

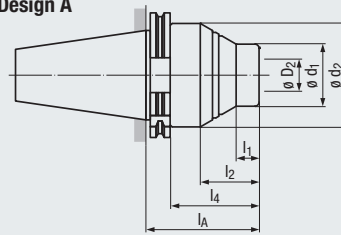

Design B

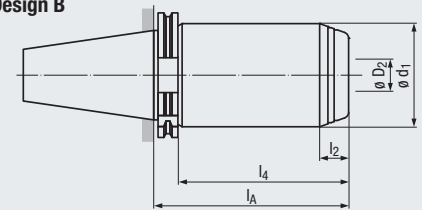

new	mm											EDP Number	
	Size	inch	$\varnothing D_2$ mm	Shank Size	Design	$\varnothing d_1$	$\varnothing d_2$	l_1	l_2	l_4	l_A		
FPC 14	1/8 - 9/16	2 - 14	SK 30	A	30	50	11	28	73	92	6491.301409	●	
			SK 40	A	30	50	11	28	43	63	6491.401406	●	
			SK 40	A	30	50	61	78	93	112	6491.401411	●	
			SK 40	A	30	50	85	103	129	149	6491.401414	●	
			SK 50	A	30	50	11	28	43	63	6491.501406	●	
			SK 50	A	30	50	85	103	129	149	6491.501414	●	
FPC 20	1/8 - 3/4	2 - 20	SK 30	A	40	50	20	28	73	92	6491.302009	●	
			SK 40	A	40	50	20	28	43	63	6491.402006	●	
			SK 40	A	40	50	69	78	93	112	6491.402011	●	
			SK 40	A	40	50	94	103	129	149	6491.402014	●	
			SK 50	A	40	63	18	38	43	62	6491.502006	●	
			SK 50	A	40	63	84	104	129	149	6491.502014	●	
FPC 25	5/8 - 1 1/4	16 - 32	SK 40	B	63	-	-	14	83	102	6491.402510 *	●	
			SK 50	B	70	-	-	15	83	102	6491.502510	●	

Note: Mechanical drive torque wrench must be set at max. 7.38 ft lbs / 10 Nm

⚠ Caution: tool does not have a safety zone. Be sure to check for tool changer interference before using.

Fine balanced design and ultra slim design available upon request

Length stop available upon request

Description of the symbols, see page 348

Accessories



FPC Collets and accessories

» 345 - 348



Pull studs available upon request

FPC

BT Shank

DIN ISO 7388-2
(formerly JIS B 6339, MAS 403 BT)

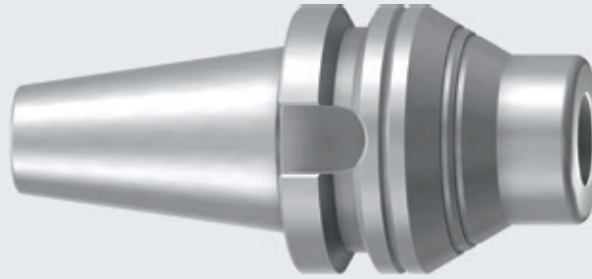



FPC



≤ 3 μm



AT3



G2.5
20 000 RPM



IKZ

Design A

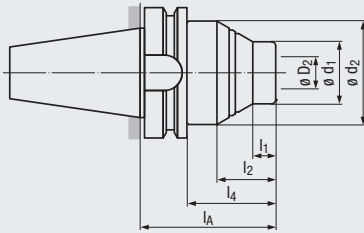

Design B

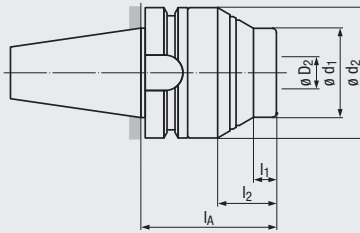

Design C

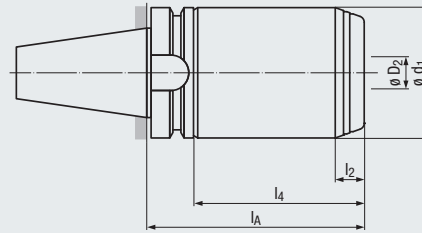

new		mm										EDP Number	
Size	$\varnothing D_2$ inch mm	Shank Size	Design	$\varnothing d_1$	$\varnothing d_2$	l_1	l_2	l_4	l_A				
FPC 14	1/8 - 9/16	2 - 14	BT 30	A	30	53	11	28	56	82	6493.301408	●	
			BT 40	A	30	50	11	28	43	70	6493.401407	●	
			BT 40	A	30	50	61	78	93	120	6493.401412	●	
			BT 40	A	30	50	85	103	129	156	6493.401415	●	
FPC 20	1/8 - 3/4	2 - 20	BT 30	A	40	53	20	31	56	82	6493.302008	●	
			BT 40	B	40	63	18	38	-	70	6493.402007	●	
			BT 40	B	40	63	48	68	-	120	6493.402012	●	
			BT 40	B	40	63	84	104	-	156	6493.402015	●	
			BT 50	A	40	63	18	38	43	81	6493.502008	●	
FPC 25	5/8 - 1 1/4	16 - 32	BT 50	A	40	63	84	104	129	167	6493.502016	●	
			BT 40	C	63	-	14	-	-	110	6493.402511	●	
			BT 50	C	70	-	15	-	83	121	6493.502512	●	

Note: Mechanical drive torque wrench must be set at **max. 7.38 ft lbs / 10 Nm**

Fine balanced design and ultra slim design available upon request

Length stop available upon request

Description of the symbols, see page 348

Accessories



FPC Collets and accessories

» 345 - 348



Pull studs available upon request

Product Finder

v_c / f_z

UNC

UNF

UN

M

MF

NPSF

Rp (BSPP)

G

W

BSW, BSF

NPT

NPTF

Rc (BSPT)

STI

SELF-LOCK

Accessories

Tech. Info

BGF

ZBGF

GSF (Aero)

GSF-Z

GF(I), GF-Z

GF-Vario-Z

GF-H

GF(I)-KEG

ZGF(I)

CIRC-GF

Gigant

FPC, FMC

MoSys



- Product Finder
- v_c / f_z
- UNC
- UNF
- UN
- M
- MF
- NPSF
- Rp (BSPP)
- G
- W
- BSW, BSF
- NPT
- NPTF
- Rc (BSPT)
- STI
- SELF-LOCK
- Accessories
- Tech. Info

FPC

PSC Shank

ISO 26623-1

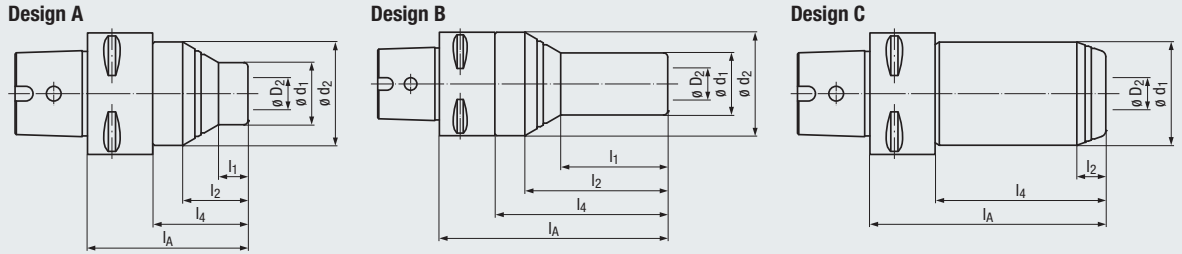
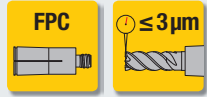
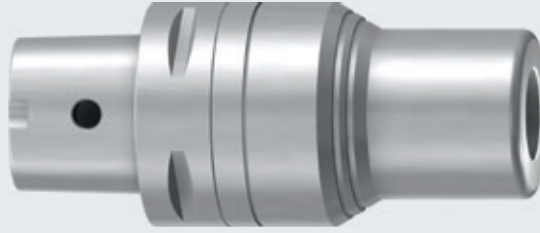

new	Size		Shank Size	Design	mm						EDP Number	
	inch	$\varnothing D_2$ mm			$\varnothing d_1$	$\varnothing d_2$	l_1	l_2	l_4	l_A		
FPC 14	1/8 - 9/16	2 - 14	PSC 50	A	30	50	61	78	93	127	6496.051412	●
			PSC 63	A	30	50	11	28	43	80	6496.061408	●
			PSC 63	A	30	50	61	78	93	130	6496.061413	●
			PSC 63	A	30	50	85	103	129	166	6496.061416	●
FPC 20	1/8 - 3/4	2 - 20	PSC 50	B	40	53	20	28.5	57	77	6496.052007	●
			PSC 63	B	40	63	18	38	-	80	6496.062008	●
			PSC 63	B	40	63	48	68	-	130	6496.062013	●
			PSC 63	B	40	63	84	104	-	166	6496.062016	●
			PSC 80	B	40	63	18	38	43	90	6496.082009	●
			PSC 80	B	40	63	48	68	93	140	6496.082014	●
FPC 25	5/8 - 1 1/4	16 - 32	PSC 63	C	63	-	-	14	-	119	6496.062511	●
			PSC 80	C	70	-	-	15	83	129	6496.082512	●

Note: Mechanical drive torque wrench must be set at **max. 7.38 ft lbs / 10 Nm**

Ultra slim design available upon request

Length stop available upon request

Description of the symbols, see page 348

Accessories



FPC Collets and accessories

» 345 - 348

FPC

± 0.217 in
(± 5,5 mm)

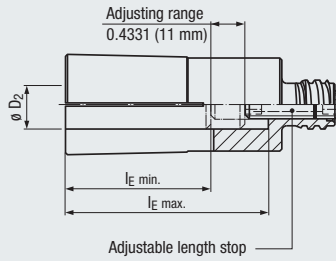

Standard version
for coolant supply
via slots in the collet



Sealed version
for tools with
internal coolant supply



Inch Size	inch				EDP Number		EDP Number	
	ø D ₂	l _E min.	l _E max.	Adjusting range				
FPC 14	1/8	0.6693	1.8898	0.4331	6638.140125	●	6639.140125	●
	3/16	0.6693	1.8898	0.4331	6638.140188	●	6639.140188	●
	1/4	0.9843	1.8898	0.4331	6638.140250	●	6639.140250	●
	5/16	0.9843	1.8898	0.4331	6638.140313	●	6639.140313	●
	3/8	1.1417	1.8898	0.4331	6638.140375	●	6639.140375	●
	7/16	1.3386	1.8898	0.4331	6638.140438	●	6639.140438	●
	1/2	1.3386	1.8898	0.4331	6638.140500	●	6639.140500	●
FPC 20	9/16	1.3386	1.8898	0.4331	6638.140563	●	6639.140563	●
	1/8	0.6693	1.8898	0.4331	6638.200125	●	6639.200125	●
	3/16	0.6693	1.8898	0.4331	6638.200188	●	6639.200188	●
	1/4	0.9843	1.8898	0.4331	6638.200250	●	6639.200250	●
	5/16	0.9843	1.8898	0.4331	6638.200313	●	6639.200313	●
	3/8	1.1417	1.8898	0.4331	6638.200375	●	6639.200375	●
	7/16	1.3386	1.8898	0.4331	6638.200438	●	6639.200438	●
	1/2	1.3386	1.8898	0.4331	6638.200500	●	6639.200500	●
	9/16	1.3386	1.8898	0.4331	6638.200563	●	6639.200563	●
	5/8	1.4567	1.8898	0.4331	6638.200625	●	6639.200625	●
FPC 25	11/16	1.4567	1.8898	0.4331	6638.200688	●	6639.200688	●
	3/4	1.5354	1.8898	0.4331	6638.200750	●	6639.200750	●
	5/8	1.4567	2.3622	0.4331	6638.250625	●	6639.250625	●
	3/4	1.5354	2.3622	0.4331	6638.250750	●	6639.250750	●
	1	1.7717	2.3622	0.4331	6638.251000	●	6639.251000	●
	1 1/4	1.8898	2.3622	0.4331	6638.251250	●	6639.251250	●

Minimum quantity lubrication (1-channel or 2-channel MQL systems) possible by exchanging the length stop, available on request

l_E min. = Minimum clamping length of the tool with length stop
l_E max. = Maximum clamping length of the tool without length stop

Product Finder

v_c / f_z

UNC

UNF

UN

M

MF

NPSF

Rp (BSPP)

G

W

BSW, BSF

NPT

NPTF

Rc (BSPT)

STI

SELF-LOCK

Accessories

Tech. Info

BGF

ZBGF

GSF (Aero)

GSF-Z

GF(I), GF-Z

GF-Vario-Z

GF-H

GF(I)-KEG

ZGF(I)

CIRC-GF

Gigant

FPC, FMC

MoSys



- Product Finder
- v_c / f_z
- UNC
- UNF
- UN
- M
- MF
- NPSF
- Rp (BSPP)
- G
- W
- BSW, BSF
- NPT
- NPTF
- Rc (BSPT)
- STI
- SELF-LOCK
- Accessories
- Tech. Info
- BGF
- ZBGF
- GSF (Aero)
- GSF-Z
- GF(I), GF-Z
- GF-Vario-Z
- GF-H
- GF(I)-KEG
- ZGF(I)
- CIRC-GF
- Gigant
- FPC, FMC
- MoSys

FPC

± 0.217 in
(± 5.5 mm)

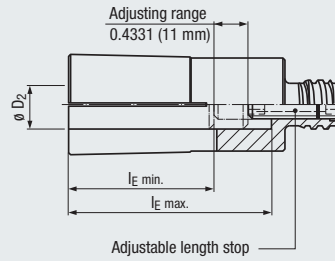

Standard version
for coolant supply
via slots in the collet

new



Sealed version
for tools with
internal coolant supply

new



Metric Size	mm				EDP Number		EDP Number		
	$\varnothing D_2$	l_E min.	l_E max.	Adjusting range					
FPC 14	2	17	48	11	6638.1402	●	6639.1402	●	
	3	17	48	11	6638.1403	●	6639.1403	●	
	4	17	48	11	6638.1404	●	6639.1404	●	
	5	17	48	11	6638.1405	●	6639.1405	●	
	6	25	48	11	6638.1406	●	6639.1406	●	
	7	25	48	11	6638.1407	●	6639.1407	●	
	8	25	48	11	6638.1408	●	6639.1408	●	
	9	29	48	11	6638.1409	●	6639.1409	●	
	10	29	48	11	6638.1410	●	6639.1410	●	
	11	34	48	11	6638.1411	●	6639.1411	●	
	12	34	48	11	6638.1412	●	6639.1412	●	
	14	34	48	11	6638.1414	●	6639.1414	●	
	FPC 20	2	17	48	11	6638.2002	●	6639.2002	●
		3	17	48	11	6638.2003	●	6639.2003	●
4		17	48	11	6638.2004	●	6639.2004	●	
5		17	48	11	6638.2005	●	6639.2005	●	
6		25	48	11	6638.2006	●	6639.2006	●	
8		25	48	11	6638.2008	●	6639.2008	●	
10		29	48	11	6638.2010	●	6639.2010	●	
11		34	48	11	6638.2011	●	6639.2011	●	
12		34	48	11	6638.2012	●	6639.2012	●	
14		34	48	11	6638.2014	●	6639.2014	●	
15		37	48	11	6638.2015	●	6639.2015	●	
16		37	48	11	6638.2016	●	6639.2016	●	
18		37	48	11	6638.2018	●	6639.2018	●	
20		39	48	11	6638.2020	●	6639.2020	●	
FPC 25	16	37	60	11	6638.2516	●	6639.2516	●	
	18	37	60	11	6638.2518	●	6639.2518	●	
	20	39	60	11	6638.2520	●	6639.2520	●	
	22	39	60	11	6638.2522	●	6639.2522	●	
	25	45	60	11	6638.2525	●	6639.2525	●	
	32	48	60	11	6638.2532	●	6639.2532	●	

Minimum quantity lubrication (1-channel or 2-channel MQL systems) possible by exchanging the length stop, available on request

l_E min. = Minimum clamping length of the tool with length stop
 l_E max. = Maximum clamping length of the tool without length stop

FPC

Use with straight shank standard tools according to DIN 6535 HB or DIN 1835 B (with Weldon flat)

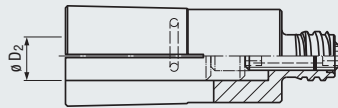

Standard version
for coolant supply via slots in the collet

Sealed version
for tools with internal coolant supply

new



new



Inch Size	inch ø D ₂	EDP Number		EDP Number	
FPC 20	1/4	6637.200250	●	6633.200250	●
	5/16	6637.200313	●	6633.200313	●
	3/8	6637.200375	●	6633.200375	●
	1/2	6637.200500	●	6633.200500	●
	5/8	6637.200625	●	6633.200625	●
FPC 25	1/2	6637.250500	●	6633.250500	●
	5/8	6637.250625	●	6633.250625	●
	3/4	6637.250750	●	6633.250750	●
	7/8	6637.250875	●	6633.250875	●
	1	6637.251000	●	6633.251000	●

Metric Size	mm ø D ₂	EDP Number		EDP Number	
FPC 20	6	6637.2006	●	6633.2006	●
	8	6637.2008	●	6633.2008	●
	10	6637.2010	●	6633.2010	●
	12	6637.2012	●	6633.2012	●
	14	6637.2014	●	6633.2014	●
	16	6637.2016	●	6633.2016	●
	18	6637.2018	●	6633.2018	●
	20	6637.2020	●	6633.2020	●
FPC 25	16	6637.2516	●	6633.2516	●
	18	6637.2518	●	6633.2518	●
	20	6637.2520	●	6633.2520	●
	22	6637.2522	●	6633.2522	●
	25	6637.2525	●	6633.2525	●

Minimum quantity lubrication (1-channel or 2-channel MQL systems) possible by exchanging the length stop, available on request

Assembly tool and 3 locking pins are included in the delivery!

Assembly Tool



new	Size	ø D ₂		ø D mm	WAF mm	EDP Number	
		inch	mm				
FPC 20		1/4 - 1/8	6 - 16 / 20	2	4	6665.055	●
		-	18	1	4	6665.056	●
FPC 25		1/2 - 1	16 - 25	2	5	6665.057	●

3 Spare Locking Pins



new	Size	ø D ₂		ø D x L	EDP Number	
		inch	mm			
FPC 20		1/4 - 1/2	6 - 14	3 x 14	6665.041	●
		5/8	16	3 x 12	6665.040	●
		-	18	2 x 12	6665.044	●
		-	20	3 x 8	6665.045	●
FPC 25		1/2 - 3/4	16 - 20	4 x 26	6665.043	●
		7/8 - 1	22 - 25	4 x 20	6665.042	●

● = In stock
★ = Allow 7 days for delivery

Product Finder

v_c / f_z

UNC

UNF

UN

M

MF

NPSF

Rp (BSPP)

G

W

BSW, BSF

NPT

NPTF

Rc (BSPT)

STI

SELF-LOCK

Accessories

Tech. Info

BGF

ZBGF

GSF (Aero)

GSF-Z

GF(I), GF-Z

GF-Vario-Z

GF-H

GF(I)-KEG

ZGF(I)

CIRC-GF

Gigant

FPC, FMC

MoSys

- Product Finder
- v_c / f_z
- UNC
- UNF
- UN
- M
- MF
- NPSF
- Rp (BSPP)
- G
- W
- BSW, BSF
- NPT
- NPTF
- Rc (BSPT)
- STI
- SELF-LOCK
- Accessories
- Tech. Info

Hexagon Torque Wrench

With marking for torque applied

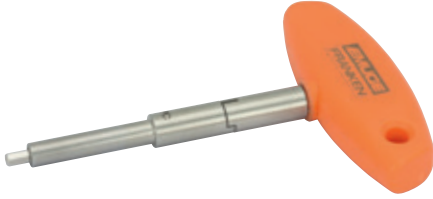

new	Width across flats	Torque	EDP Number	
	SW4 (4 mm)	7.38 ft lbs / 10 Nm	6665.014	●

Hexagon Torque Wrench

With break-away signal

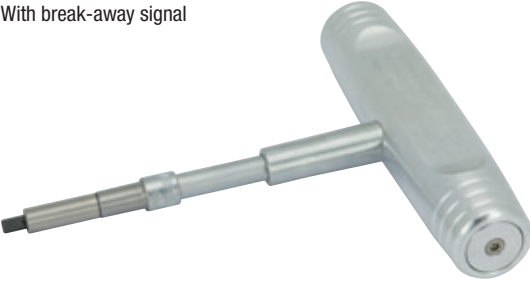

new	Width across flats	Torque	EDP Number	
	SW4 (4 mm)	7.38 ft lbs / 10 Nm	6665.011	●

Spare Bit

With guidance tube



new	Width across flats	EDP Number	
	SW4 (4 mm)	6665.018	●



Taper Cleaners

For cleaning the inside cone of FPC collet holders

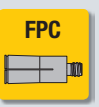
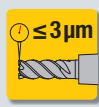

new	For Size	EDP Number	
	FPC 14	6665.030	●
	FPC 20	6665.031	●
	FPC 25	6665.032	●

Description of the Symbols

 <p>FPC For use with FPC collets only</p>	 <p>$\leq 3\mu m$ < 3μm (micron) runout at 3 x diameter length</p>
 <p>G2.5 20000 RPM Balanced to G2.5, 20,000 RPM</p>	 <p>AT3 Taper quality AT3</p>

FMC Cylindrical Shank

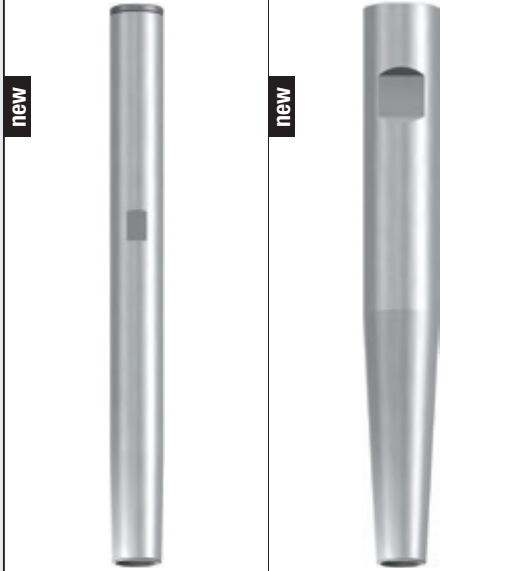
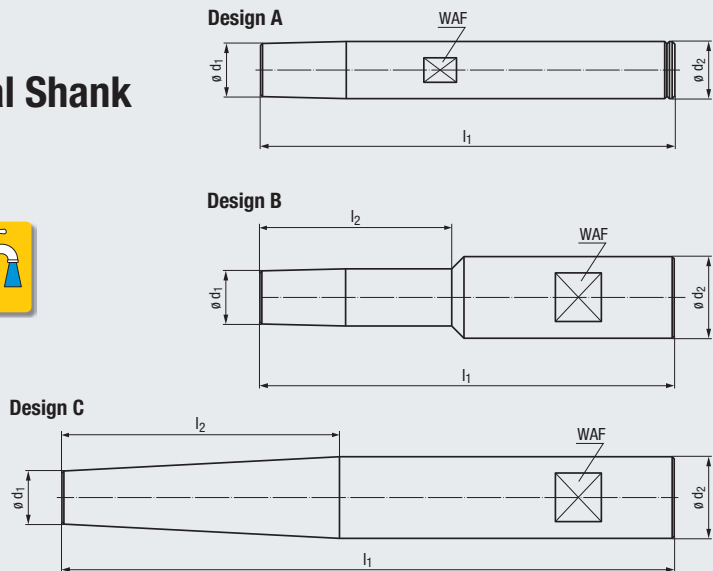

Size	Design	mm			WAF	EDP Number		EDP Number	
		ϕd_1	l_2	ϕd_2 h6					
100	A	13	—	14	13	6495.14100A	●		
150	A	13	—	14	13	6495.14150A	●		
190	A	13	—	14	13	6495.14190A	●		
100	B	13	45	20	16			6495.14100B	●
150	C	13	67	20	16			6495.14150B	●

A hexagon wrench is included in delivery

FMC



Standard version
for coolant supply
via slots in the collet

Sealed version
for tools with
internal coolant supply

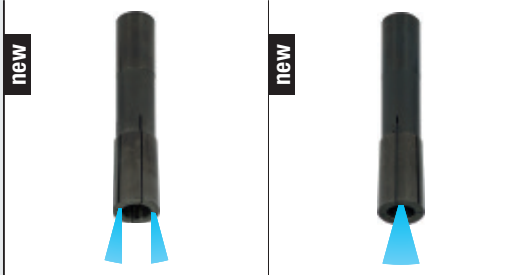

Inch	EDP Number		EDP Number	
ϕD_2				
1/8	6648.060125	●	6649.060125	●
3/16	6648.060188	●	6649.060188	●
1/4	6648.060250	●	6649.060250	●

Metric	EDP Number		EDP Number	
ϕD_2 mm				
1	6648.0601	●	6649.0601	●
2	6648.0602	●	6649.0602	●
3	6648.0603	●	6649.0603	●
4	6648.0604	●	6649.0604	●
5	6648.0605	●	6649.0605	●
6	6648.0606	●	6649.0606	●

Hexagon Torque Wrench

for FMC collet extensions



new	Width across flats	L	Torque	EDP Number	
	SW4 (4 mm)	220	1.11 - 2.21 ft lbs / 1.5 - 3 Nm	6665.020	●

● = In stock
★ = Allow 7 days for delivery

Product Finder

v_c / f_z

UNC

UNF

UN

M

MF

NPSF

Rp (BSPP)

G

W

BSW, BSF

NPT

NPTF

Rc (BSPT)

STI

SELF-LOCK

Accessories

Tech. Info

BGF

ZBGF

GSF (Aero)

GSF-Z

GF(I), GF-Z

GF-Vario-Z

GF-H

GF(I)-KEG

ZGF(I)

CIRC-GF

Gigant

FPC FMC

MoSys

- Product Finder
- v_c / f_z
- UNC
- UNF
- UN
- M
- MF
- NPSF
- Rp (BSPP)
- G
- W
- BSW, BSF
- NPT
- NPTF
- Rc (BSPT)
- STI
- SELF-LOCK
- Accessories
- Tech. Info

“MoSys” makes a large number of counterbore and stepped bore operations possible!

With just one clamping operation, you enjoy a number of advantages:

- Smaller tool quantities
- Fewer magazine places and reduced stocking costs
- Shorter machining times

“MoSys” answers to the following requirements:

- Easy assembly
- High degree of rigidity
- High dimensional precision
- Modular construction for universal application

MoSys with solid carbide head

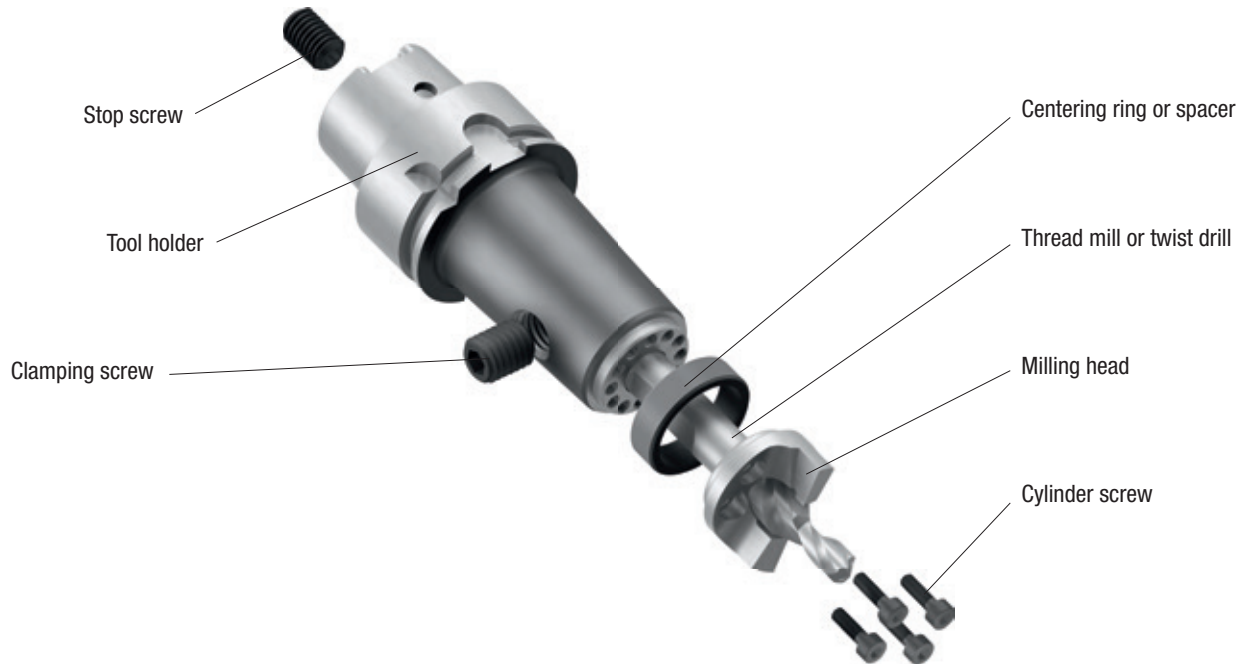

MoSys with indexable inserts

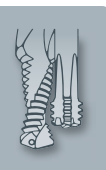
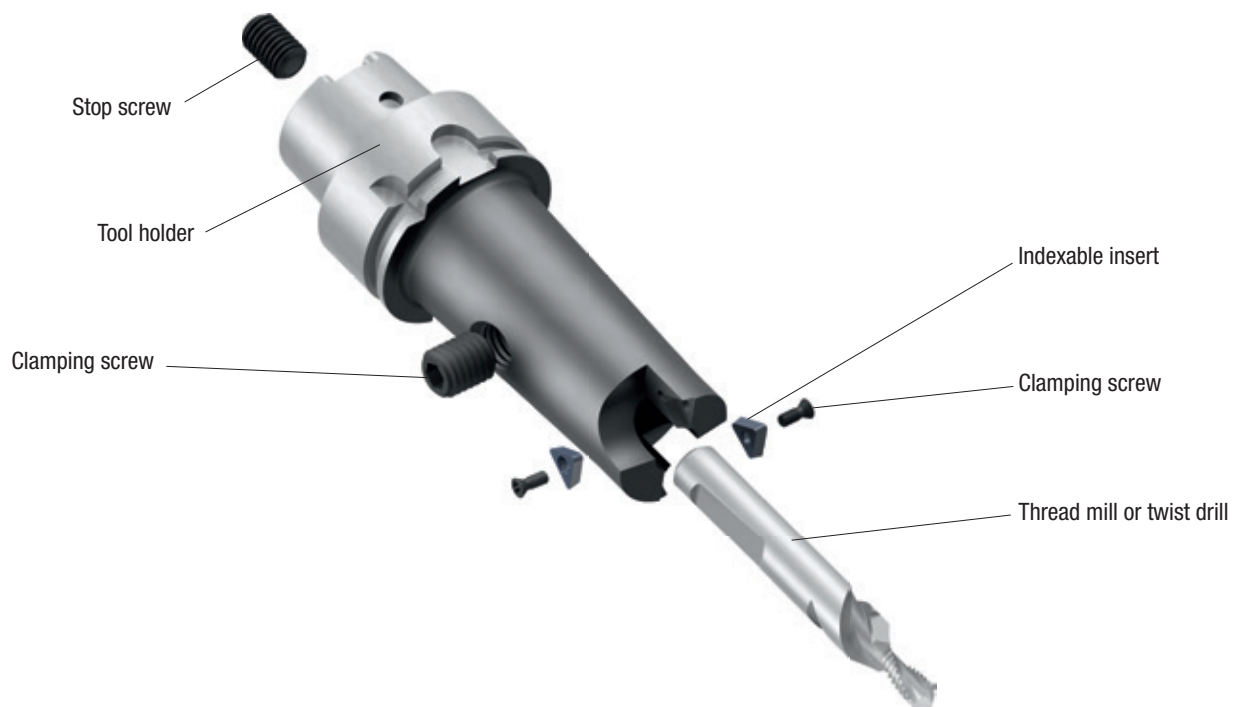

ISO taper shanks



Hollow taper shanks



Connection for milling head



Connection for indexable inserts

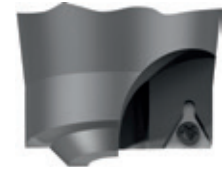
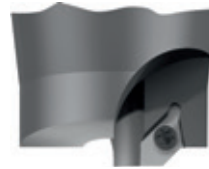

Centering ring



Solid carbide milling heads



Indexable inserts for plane milling and chamfering



Indexable inserts for plane milling



Thread mills or twist drills

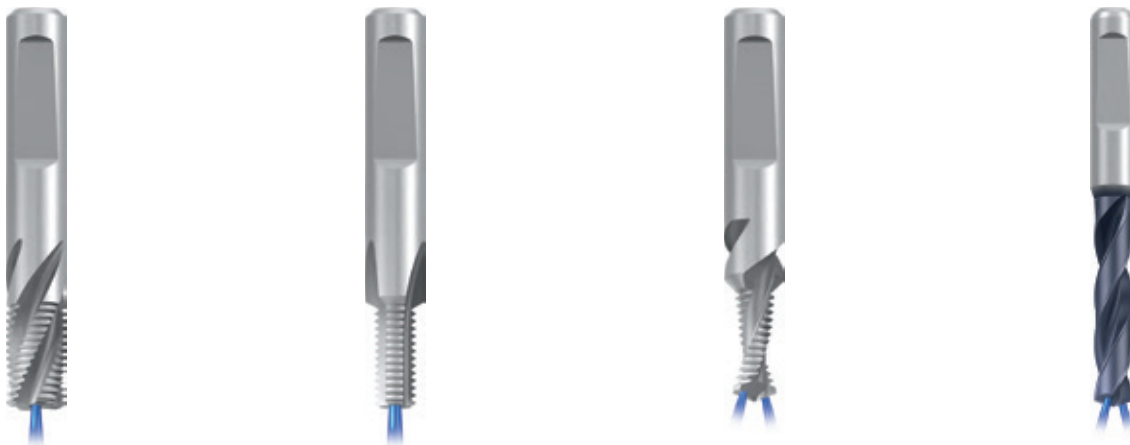

Product Finder

v_c / f_z

UNC

UNF

UN

M

MF

NPSF

Rp (BSPP)

G

W

BSW, BSF

NPT

NPTF

Rc (BSPT)

STI

SELF-LOCK

Accessories

Tech. Info

BGF

ZBGF

GSF (Aero)

GSF-Z

GF(I), GF-Z

GF-Vario-Z

GF-H

GF(I)-KEG

ZGF(I)

CIRC-GF

Gigant

FPC, FMC

MoSys



Product Finder

v_c / f_z

UNC

UNF

UN

M

MF

NPSF

Rp (BSPP)

G

W

BSW, BSF

NPT

NPTF

Rc (BSPT)

STI

SELF-LOCK

Accessories

Tech. Info

BGF

ZBGF

GSF (Aero)

GSF-Z

GF(I), GF-Z

GF-Vario-Z

GF-H

GF(I)-KEG

ZGF(I)

CIRC-GF

Gigant

FPC, FMC

MoSys

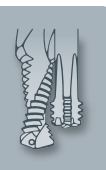

For submitting an offer, we need the following information:

- Workpiece drawing with possible obstruction contours
- Shank connection on the machine side, with coolant supply
- Detailed countersink contour
- Size of the thread to be produced, including thread depth
- Type of hole (through hole or blind hole)
- Drilled hole diameter (if known)
- Workpiece material

Example for machining with solid carbide head

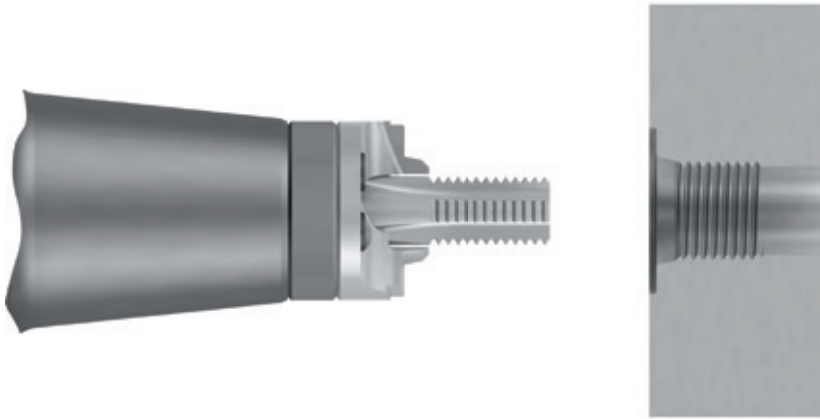

Example for machining with indexable inserts

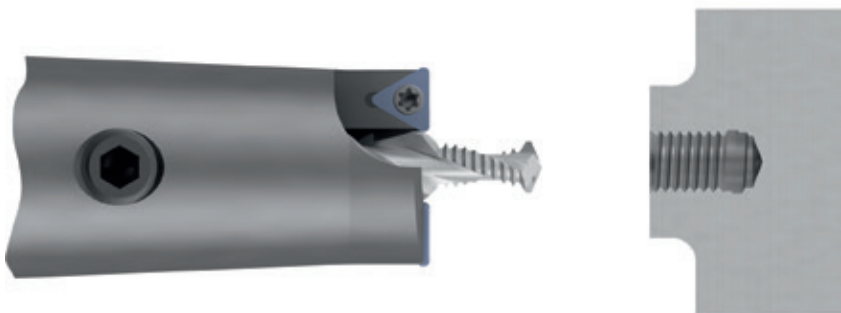

Technical Information

		Page
4.1	Characteristics and advantages of thread milling	354
4.2	Our EMUGE thread mill types	354 - 356
4.3	Possible modifications on thread mills	357
4.4	Calculation of cutting data	358
4.5	Thread milling processes (right-hand thread)	359
4.6	Problems, possible causes and solutions in thread milling	360 - 361

Product
Finder v_c / f_z

UNC

UNF

UN

M

MF

NPSF

Rp (BSPP)

G

W

BSW, BSF

NPT

NPTF

Rc (BSPT)

STI

SELF-LOCK

Accessories

Tech. Info

BGF

ZBGF

GSF (Aero)

GSF-Z

GF(I), GF-Z

GF-Vario-Z

GF-H

GF(I)-KEG

ZGF(I)

CIRC-GF

Gigant

FPC, FMC

MoSys



- Product Finder
- v_c / f_z
- UNC
- UNF
- UN
- M
- MF
- NPSF
- Rp (BSPP)
- G
- W
- BSW, BSF
- NPT
- NPTF
- Rc (BSPT)
- STI
- SELF-LOCK
- Accessories

Tech. Info

- BGF
- ZBGF
- GSF (Aero)
- GSF-Z
- GF(I), GF-Z
- GF-Vario-Z
- GF-H
- GF(I)-KEG
- ZGF(I)
- CIRC-GF
- Gigant
- FPC, FMC
- MoSys

4.1 Characteristics and advantages of thread milling

Thread milling – A technology which can reduce your production costs considerably!

With the more and more widespread use of CNC technology, the basic conditions for a future-oriented technique of producing internal and external threads have been created.

Thread milling can be practiced without any trouble and with a high degree of process safety if your CNC machine is provided with a control for 3D-interpolation. In addition to that, you need stable and vibration-free tool and workpiece clamping, and internal coolant supply.

In case you should have little or no experience with the programming of the control, our technicians will be happy to help you by word and deed. We are also ready, at any time, to provide in-house or on-location training for you with practical machining examples.

Please contact our sales personnel.

Thread milling is, in a multitude of application cases, a highly recommendable alternative to tapping or cold-forming of threads, with the following advantages:

- Short production times
- High degree of process safety
- Very good surface quality
- Combination of different machining jobs with one tool
- Usable thread depth down to the very bottom of the hole
- No expensive lubricants are needed
- No chip problems, since only short milling chips are created
- No axial miscutting (overcut) of the thread
- Universal use in the most different materials up to approx. 60 HRC
- Blind hole and through hole threads produced with one tool
- Thread production independent of thread size and tolerance
- One tool only for right-hand and left-hand threads
- Low cutting forces
- Suitable also for thin-walled components

4.2 Our EMUGE thread mill types

BGF



Solid carbide drill thread mills

- For the production of internal threads
- For the complete machining of thread hole, chamfer and thread in one work process
- Tool for one single thread size with corrected thread profile

Designs:

- 2-fluted: For work in solid material
- 3-fluted: For work in pre-cast thread holes and in solid material

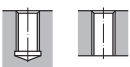

ZBGF



Solid carbide circular drill thread mills

- For the production of internal threads
- For the machining of thread hole and thread in one work process
- Tool for different thread sizes but for one pitch only, with corrected thread profile

Designs:

- ZBGF-T: For thread depths up to 3 x D in aluminum and cast iron
- ZBGF-H: For hard machining from 44 HRC
- ZBGF-W: For the most different materials up to 44 HRC

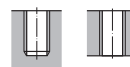

4.2 Our EMUGE thread mill types

GSF, GSF Aero

**Solid carbide thread mills with countersinking step**

- For the production of internal threads
- For the machining of chamfer and thread in one work process
- Tool for one single thread size, with corrected thread profile
- A ready prepared thread hole is necessary

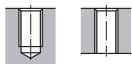

GSF-Z

**Solid carbide thread mills with countersinking step**

- For the production of internal threads
- For the machining of chamfer and thread in one work process
- Tool for one single thread size, with corrected thread profile
- Increased number of flutes compared with type GSF
- Optimized cutting geometry
- A ready prepared thread hole is necessary

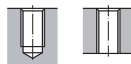

GF, GFI

**Solid carbide thread mills**

- For the production of internal and external threads
- Tool for different thread sizes with standard thread profile (but for one pitch only)
- A ready prepared thread hole is necessary, including chamfer if needed
- In order to avoid serious profile deviation in internal threads, the cutter diameter should not exceed $\frac{2}{3}$ (with fine threads, $\frac{3}{4}$) of the thread to be produced
- With external threads, the cutter diameter should not exceed the diameter of the thread to be produced



GF-Z

**Solid carbide thread mills**

- For the production of internal threads
- Tool for different thread sizes with standard thread profile (but for one pitch only)
- Increased number of flutes compared with type GF
- Optimized cutting geometry
- A ready prepared thread hole is necessary, including chamfer if needed
- In order to avoid serious profile deviation in internal threads, the cutter diameter should not exceed $\frac{2}{3}$ (with fine threads, $\frac{3}{4}$) of the thread to be produced

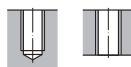

GF-Vario-Z

**Solid carbide thread mills, variable**

- For the production of internal threads
- Tool for different thread sizes, but for one pitch only, with corrected thread profile
- Large number of flutes
- Optimized cutting geometry
- A ready prepared thread hole is necessary, including chamfer if needed



GF-H

**Solid carbide thread mills for hard machining**

- For the production of internal threads
- Tool for one single thread size, with corrected thread profile
- A ready prepared thread hole is necessary, including chamfer if needed

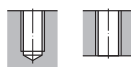
Product
Finder v_c / f_z

UNC

UNF

UN

M

MF

NPSF

Rp (BSPP)

G

W

BSW, BSF

NPT

NPTF

Rc (BSPT)

STI

SELF-LOCK

Accessories

Tech. Info

BGF

ZBGF

GSF (Aero)

GSF-Z

GF(I), GF-Z

GF-Vario-Z

GF-H

GF(I)-KEG

ZGF(I)

CIRC-GF

Gigant

FPC, FMC

MoSys



Product Finder
v_c / f_z
UNC
UNF
UN
M
MF
NPSF
Rp (BSPP)
G
W
BSW, BSF
NPT
NPTF
Rc (BSPT)
STI
SELF-LOCK
Accessories

4.2 Our EMUGE thread mill types

GF-KEG, GFI-KEG, GFI-ECO-KEG



Solid carbide thread mills for tapered threads

- For the production of tapered internal threads
- Tool for one single thread size, resp. for one pitch only, with corrected thread profile
- A ready prepared cylindrical, or even better, tapered, thread hole is necessary, including chamfer if needed

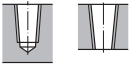

ZGF, ZGFI



Solid carbide circular thread mills

- For the production of internal threads from No. 0-80 or M1
- **ZGF**
Tool for different thread sizes and pitches, with corrected thread profile
- **ZGF-S-CUT**
Tool for one single thread size, with corrected thread profile
- **ZGF-HCUT**
Tool for one single thread size, with corrected thread profile
- A ready prepared thread hole is necessary, including chamfer if needed

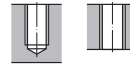

Tech. Info

CIRC-GF



Circular thread milling bodies

- For the production of internal and external threads
- With one or two multi-tooth inserts
- Tool for different thread sizes, but for one pitch only
- A ready prepared thread hole is necessary, including chamfer if needed
- In order to avoid serious profile deviation in internal threads, the cutter diameter should not exceed $\frac{2}{3}$ (with fine threads, $\frac{3}{4}$) of the thread to be produced



CIRC-GF



Circular thread milling bodies

- For the production of internal and external threads
- With one infeed indexable insert, "3-tooth" design
- Tool for different thread sizes and pitches
- A ready prepared thread hole is necessary, including chamfer if needed
- In order to avoid serious profile deviation in internal threads, the cutter diameter should not exceed $\frac{2}{3}$ (with fine threads, $\frac{3}{4}$) of the thread to be produced



Gigant



Circular thread milling bodies

- For the production of large internal and external threads
- With up to ten 4-tooth indexable inserts (independent of pitch)
- Tool for different thread sizes and pitches
- A ready prepared thread hole is necessary, including chamfer if needed



4.3 Possible modifications on thread mills

Face chamfer (with or without cutting face)

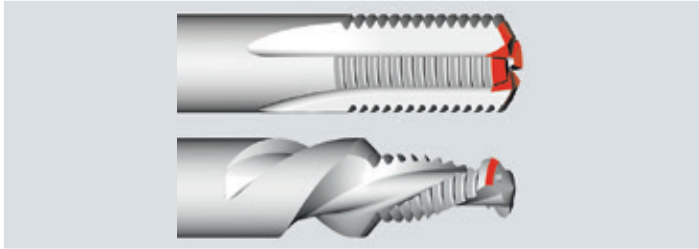
**Suitable for:**

- All types GF and GSF
- All types BGF (face chamfer on the drilling part)

Note:

- Face chamfer for circular chamfering of the thread hole
- Additional cutting face for circular face milling

Recessed neck

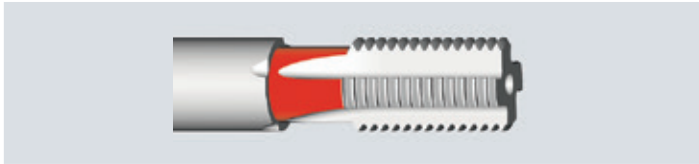
**Suitable for:**

- All types GF and GSF (no countersinking step)

Note:

- For larger thread depths (total thread depth is achieved by a double milling process)
- For constant cutting pressure, the thread part length and the neck length are arranged in a ratio of 1:1!
- The thread part length and the offset for a second milling process are always a whole-number multiple of the thread pitch

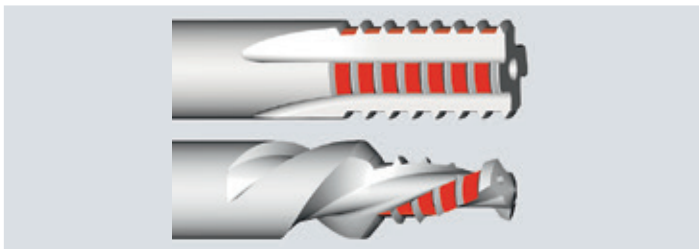
AZR – Radially alternating tooth rows**Suitable for:**

- All types GF, GSF and BGF

Note:

- **AZR** helps to reduce lateral forces in thread milling; the alternating missing gaps in the thread are produced by additional circular milling orbits

There is another variant, not shown here, called **AZ** (alternating teeth in a staggered sequence)

Advantage:

- No additional circular orbits are necessary; due to this, there is a perfectly normal recess depth at the hole bottom, if BGF type tools are used

Removal of incomplete thread

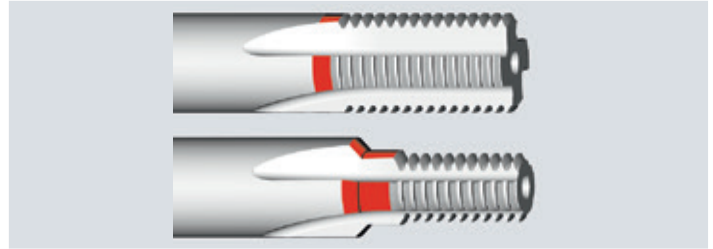
**Suitable for:**

- All types GF, GSF and BGF

Note:

- At the rear end of the thread part, a step with a length of min. $1 \times P$ is relief-ground
- If the tool plunges to a correct depth during the thread milling process, the incomplete thread run-out with its burr is milled off (removed)

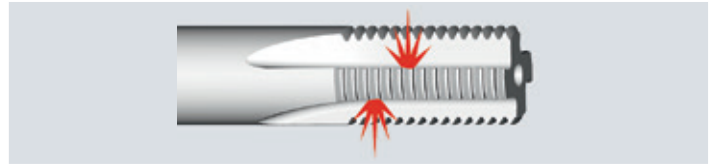
IKZN – Internal coolant supply exiting in the flutes**Suitable for:**

- All types GF and GSF

Note:

- Axial coolant bore closed up at the tool face for the production of through hole threads
- For maximum stability of the cutting part, the lateral coolant holes are axially staggered

Coolant grooves along the shank

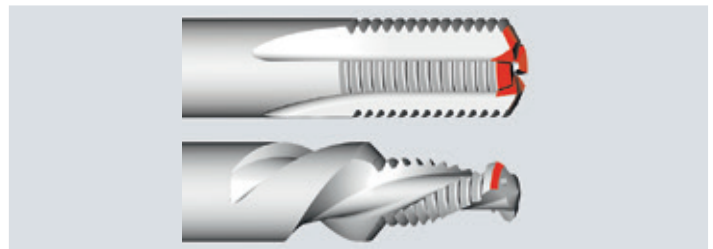
**Suitable for:**

- All types GF, GSF and BGF

Note:

- For the production of through hole threads
- In addition or as an alternative to IKZ or IKZN
- Possible support in the cooling of the countersinking step of GSF and BGF type tools, or of the plane milling head in MoSys applications

Product
Finder v_c / f_z

UNC

UNF

UN

M

MF

NPSF

Rp (BSPP)

G

W

BSW, BSF

NPT

NPTF

Rc (BSPT)

STI

SELF-LOCK

Accessories

Tech. Info

BGF

ZBGF

GSF (Aero)

GSF-Z

GF(I), GF-Z

GF-Vario-Z

GF-H

GF(I)-KEG

ZGF(I)

CIRC-GF

Gigant

FPC, FMC

MoSys



- Product Finder
- v_c / f_z
- UNC
- UNF
- UN
- M
- MF
- NPSF
- Rp (BSPP)
- G
- W
- BSW, BSF
- NPT
- NPTF
- Rc (BSPT)
- STI
- SELF-LOCK
- Accessories

4.4 Calculation of cutting data

Cutting speed v_c

$$v_c = \frac{d_1 \cdot \pi \cdot n}{12} \text{ [SFM]}$$

d_1 = Milling part diameter in inch
 n = Speed in rpm

$$v_c = \frac{d_1 \cdot \pi \cdot n}{1000} \text{ [m/min]}$$

d_1 = Milling part diameter in mm
 n = Speed in rpm

Speed n

$$n = \frac{v_c \cdot 12}{d_1 \cdot \pi} \text{ [rpm]}$$

d_1 = Milling part diameter in inch
 v_c = Cutting speed in SFM

$$n = \frac{v_c \cdot 1000}{d_1 \cdot \pi} \text{ [rpm]}$$

d_1 = Milling part diameter in mm
 v_c = Cutting speed in m/min

Feed speed contour v_f

$$v_f = f_z \cdot Z \cdot n \text{ [inch/min]}$$

f_z = Feed per tooth in inch
 Z = No. of flutes

$$v_f = f_z \cdot Z \cdot n \text{ [mm/min]}$$

f_z = Feed per tooth in mm
 Z = No. of flutes

Feed speed center orbit (with internal threads) v_{fM}

$$v_{fM} = \frac{v_f \cdot (D - d_1)}{D} \text{ [inch/min]}$$

v_f = Feed speed in inch/min
 D = Nominal thread diameter in inch
 d_1 = Milling part diameter in inch

$$v_{fM} = \frac{v_f \cdot (D - d_1)}{D} \text{ [mm/min]}$$

v_f = Feed speed in mm/min
 D = Nominal thread diameter in mm
 d_1 = Milling part diameter in mm

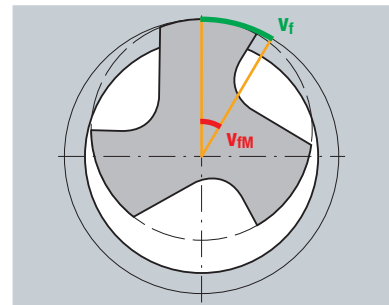

Feed speed center orbit (with external threads) v_{fM}

$$v_{fM} = \frac{v_f \cdot (D + d_1)}{D} \text{ [inch/min]}$$

v_f = Feed speed in inch/min
 D = Nominal thread diameter in inch
 d_1 = Milling part diameter in inch

$$v_{fM} = \frac{v_f \cdot (D + d_1)}{D} \text{ [mm/min]}$$

v_f = Feed speed in mm/min
 D = Nominal thread diameter in mm
 d_1 = Milling part diameter in mm

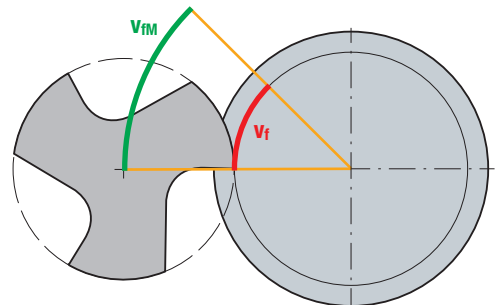

The contour feed entered is recalculated to the center orbit by the machine!
 If this should not happen (to be recognized by the noticeably increased machining speed or by tool breakage), then the center orbit feed must be entered manually.

4.5 Thread milling processes (right-hand thread)

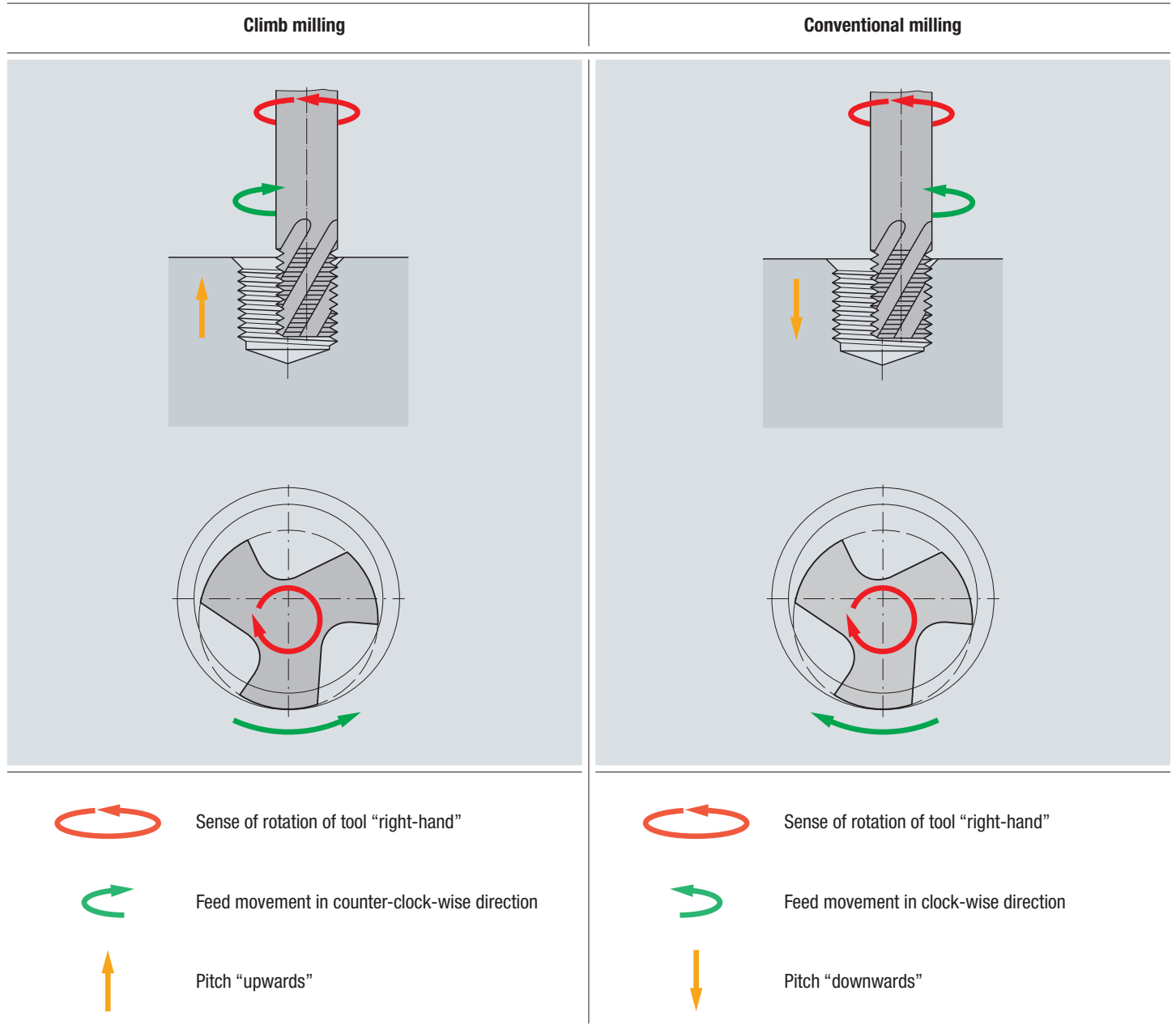

Product Finder

v_c / f_z

UNC

UNF

UN

M

MF

NPSF

Rp (BSPP)

G

W

BSW, BSF

NPT

NPTF

Rc (BSPT)

STI

SELF-LOCK

Accessories

Tech. Info

BGF

ZBGF

GSF (Aero)

GSF-Z

GF(I), GF-Z

GF-Vario-Z

GF-H

GF(I)-KEG

ZGF(I)

CIRC-GF

Gigant

FPC, FMC

MoSys



Product Finder

v_c / f_z

UNC

UNF

UN

M

MF

NPSF

Rp (BSPP)

G

W

BSW, BSF

NPT

NPTF

Rc (BSPT)

STI

SELF-LOCK

Accessories

Tech. Info

BGF

ZBGF

GSF (Aero)

GSF-Z

GF(I), GF-Z

GF-Vario-Z

GF-H

GF(I)-KEG

ZGF(I)

CIRC-GF

Gigant

FPC, FMC

MoSys

4.6 Problems, possible causes and solutions in thread milling

~ Check

↑ Increase

↓ Decrease

CLM Climb milling

COM Conventional milling

Possible causes

Cutting speed

Feed per tooth

Stability (workpiece/workpiece clamping)

Stability (tool/machine)

Protruding length (of tool)

Tool helix (spiral flutes)

Concentricity

Coating (e.g. TiN, TiCN)

Milling process/program/programmed radius

Work case (relation of tool/thread diameters)

Tool change (worn tool)

NC axis/path speed (computer)

Drilling speed (lifting)

Coolant pressure (exit bore)

Thread milling in general

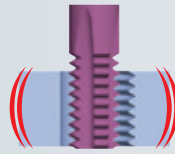

Chattering, vibrations

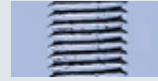

Bad surface quality on workpiece



Excessive wear





Chipped cutting edges

Solutions

Possible causes	Chattering, vibrations	Bad surface quality on workpiece	Excessive wear	Chipped cutting edges
Cutting speed	~	~	↓	
Feed per tooth	~	~	↑	↓
Stability (workpiece/workpiece clamping)	↑	↑	↑	↑
Stability (tool/machine)	↑	↑	↑	↑
Protruding length (of tool)	↓	↓	↓	~
Tool helix (spiral flutes)	↑	↑	~	~
Concentricity	~	~	~	
Coating (e.g. TiN, TiCN)			↑	↑
Milling process/program/programmed radius			CLM	CLM
Work case (relation of tool/thread diameters)				
Tool change (worn tool)				
NC axis/path speed (computer)	~	~	~	~
Drilling speed (lifting)				
Coolant pressure (exit bore)			~	~

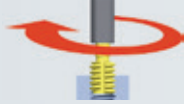
4.6 Problems, possible causes and solutions in thread milling

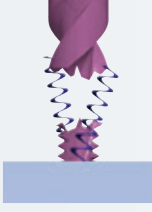
Thread milling in general			Drill thread milling	
				
Tapered thread shape (gauge jams after reaching a certain depth)	Small difference between go and no-go gaging	Marks in the run-in area	Tooth chipping on the drill thread mill	Tool breakage during the drilling process
Solutions				
			~	
↓			~	
↑		~		
↑		~		
↓				
~				
	~		~	~
COM		~	~	
	~			
	~			
~		~	~	
			~	↓ ~
			~	~

Product Finder

v_c / f_z

UNC

UNF

UN

M

MF

NPSF

Rp (BSPP)

G

W

BSW, BSF

NPT

NPTF

Rc (BSPT)

STI

SELF-LOCK

Accessories

Tech. Info

BGF

ZBGF

GSF (Aero)

GSF-Z

GF(I), GF-Z

GF-Vario-Z

GF-H

GF(I)-KEG

ZGF(I)

CIRC-GF

Gigant

FPC, FMC

MoSys



Product
Finder

v_c / f_z

UNC

UNF

UN

M

MF

NPSF

Rp (BSPP)

G

W

BSW, BSF

NPT

NPTF

Rc (BSPT)

STI

SELF-LOCK

Accessories

Tech. Info

BGF

ZBGF

GSF (Aero)

GSF-Z

GF(I), GF-Z

GF-Vario-Z

GF-H

GF(I)-KEG

ZGF(I)

CIRC-GF

Gigant

FPC, FMC

MoSys





- 3 x D
- 5 x D
- 6 x D
- 8 x D
- 2-3.5 x D

Twist Drills

	Page
Contents	364 - 365
Product Finder and Cutting Data	366 - 379
Product Pages	380 - 418
Technical Information	419 - 428



- Product Finder
- v_c / f
- STEEL
- VA
- Accessories
- Tech. Info



	Page			
STEEL	381	382 - 385	386 - 389	390 - 393
VA			398 - 401	402 - 405

- 3 x D
- 5 x D
- 6 x D
- 8 x D
- 2-3.5 x D

	Page
<p>142° NC Spot Drills</p> 	414
<p>NC Spot / Chamfer Drills</p> 	415
<p>Chamfer Mills</p> 	416
<p>HSS Countersinks</p> 	417



Product
Finder

v_c / f

STEEL

VA

Accessories

Tech. Info

EF-Drill



8 x D

EF-Drill Modular



3 x D, 5 x D

Chamfer drills 90°

EF-Drill
C



2 - 3.5 x D

Page

394 - 397

406 - 411

412

STEEL

VA

3 x D

5 x D

6 x D

8 x D

2-3.5 x D



- Product Finder
- v_c / f
- STEEL
- VA
- Accessories
- Tech. Info

Product finder and cutting data







Please note:
The suitability of the twist drills is marked in the respective columns as follows:

- = very suitable
- = suitable

The appropriate cutting speeds v_c [SFM] and feed per revolution values f [in/rev.] are to be found on pages 370 - 379

Coolant-lubricant recommendation

Application – Material		Hardness Range			Material Examples	Coolant-lubricant recommendation				
		HRC	BHN	N/mm ²		Emulsion	Oil	Minimum quantity lubrication (MQL)	Dry / Pressurized air	
Steel materials										
P	1.1	Cold-extrusion steels, Construction steels, Free-cutting steels, etc.		≤ 180	≤ 600	1010 / 1018 / 1020 / 12L14 / 12L15 / A36 / T1	■	■	□	
	2.1	Construction steels, Cementation steels, Steel castings, etc.	≤ 22	≤ 235	≤ 800	A36 / T1 / 1030-1095 / 4140 / 4340 / 8620	■	■	□	
	3.1	Cementation steels, Heat-treatable steels, Cold work steels, etc.	≤ 31	≤ 295	≤ 1000	4140 / 4340 / 8620 / P20 / H13 / D2 / A2 / S7 / H1150	■	■	□	
	4.1	Heat-treatable steels, Cold work steels, Nitriding steels, etc.	≤ 38	≤ 355	≤ 1200	4140 / 4340 / 8620 / P20 / H13 / D2 / 300M / 52100 / M1-M42	■	■	□	
	5.1	High-alloyed steels, Cold work steels, Hot work steels, etc.	≤ 44	≤ 415	≤ 1400	4140 / 4340 / 8620 / P20 / H13 / D2 / 300M / 52100	■	■	□	
Stainless steel materials										
M	1.1	Ferritic, martensitic	≤ 29	≤ 280	≤ 950	410 / 440 / 440C / 17-4 PH	■	□		
	2.1	Austenitic	≤ 29	≤ 280	≤ 950	303 / 304 / 316 / 316L / 321	■	□		
	3.1	Austenitic-ferritic (Duplex)	≤ 35	≤ 325	≤ 1100		■	□		
	4.1	Austenitic-ferritic heat-resistant (Super Duplex)	≤ 39	≤ 370	≤ 1250		■	□		
Cast materials										
K	1.1	Cast iron with lamellar graphite (GJL)		30 - 75	100 - 250	Grey cast irons G10-GG40	■		□	□
	1.2			75 - 135	250 - 450		■		□	□
	2.1	Cast iron with nodular graphite (GJS)		105 - 150	350 - 500	Nodular GGG40-GGG70	■		□	□
	2.2			150 - 265	500 - 900		■		□	□
	3.1	Cast iron with vermicular graphite (GJV)		90 - 120	300 - 400	Compact graphite iron (CGI)	■		□	□
	3.2			120 - 150	400 - 500		■		□	□
	4.1	Malleable cast iron (GTMW, GTMB)		70 - 145	250 - 500	White iron	■		□	□
	4.2			150 - 235	500 - 800		■		□	□
Non ferrous materials										
Aluminum alloys										
N	1.1	Aluminum wrought alloys		≤ 60	≤ 200	7075	■	□		
	1.2			≤ 105	≤ 350	6061-T6 / 2024-T4	■	□		
	1.3			≤ 165	≤ 550		■	□		
	1.4	Aluminum cast alloys Si ≤ 7%				■	□			
	1.5	Aluminum cast alloys 7% < Si ≤ 12%				■	□			
	1.6	Aluminum cast alloys 12% < Si ≤ 17%				■	□			
Copper alloys										
N	2.1	Pure copper, low-alloyed copper		≤ 120	≤ 400		■	□		
	2.2	Copper-zinc alloys (brass, long-chipping)		≤ 165	≤ 550		■	□		
	2.3	Copper-zinc alloys (brass, short-chipping)		≤ 165	≤ 550		■	□		
	2.4	Copper-aluminum alloys (alu bronze, long-chipping)		≤ 235	≤ 800		■	□		
	2.5	Copper-tin alloys (tin bronze, long-chipping)		≤ 205	≤ 700		■	□		
	2.6	Copper-tin alloys (tin bronze, short-chipping)		≤ 120	≤ 400		■	□		
	2.7	Special copper alloys		≤ 180	≤ 600		■	□		
	2.8			≤ 44	≤ 415	≤ 1400	■	□		
Magnesium alloys										
N	3.1	Magnesium wrought alloys		≤ 150	≤ 500					
	3.2	Magnesium cast alloys		≤ 150	≤ 500					
Synthetics										
N	4.1	Duroplastics (short-chipping)								
	4.2	Thermoplastics (long-chipping)								
	4.3	Fibre-reinforced synthetics (fibre content ≤ 30%)								
	4.4	Fibre-reinforced synthetics (fibre content > 30%)								
Special materials										
S	5.1	Graphite								■
	5.2	Tungsten-copper alloys								
	5.3	Composite materials								
Special materials										
Titanium alloys										
S	1.1	Pure titanium		≤ 135	≤ 450	CP1 / CP2				
	1.2	Titanium alloys		≤ 265	≤ 900	6AL4V	■	□		
	1.3			≤ 39	≤ 370	≤ 1250	■	□		
Nickel alloys, cobalt alloys and iron alloys										
S	2.1	Pure nickel		≤ 180	≤ 600					
	2.2	Nickel-base alloys		≤ 295	≤ 1000	Monel 500, 718 Inconel annealed	■			
	2.3			≤ 49	≤ 475	≤ 1600	718 Inconel	■		
	2.4	Cobalt-base alloys		≤ 31	≤ 295	≤ 1000				
	2.5			≤ 49	≤ 475	≤ 1600	Haynes 25			
	2.6	Iron-base alloys		≤ 46	≤ 445	≤ 1500	Incoloy 925			
Hard materials										
H	1.1	High strength steels, hardened steels, hard castings		44 - 50			■	■	□	□
	1.2			50 - 55			■	■	□	□
	1.3			55 - 60						
	1.4			60 - 63						
	1.5			63 - 66						

							
EF-Drill Micro STEEL	EF-Drill STEEL	EF-Drill STEEL			EF-Drill VA		Type
6 x D	3 x D	3 x D	5 x D	8 x D	3 x D	5 x D	Drill depth
381	382 - 385	386 - 389	390 - 393	394 - 397	398 - 401	402 - 405	Page

■	■	■	■	■			1.1	P
■	□	■	■	■			2.1	
■	□	■	■	■			3.1	
■	□	■	■	■			4.1	
■	□	■	■	■			5.1	
■		■	■	■	■	■	1.1	M
□					■	■	2.1	
□					■	■	3.1	
□					■	■	4.1	
□	□	□	□	□			1.1	K
□	□	□	□	□			1.2	
□	□	□	□	□			2.1	
□	□	■	■	■			2.2	
□	□	□	□	□			3.1	
□	□	□	□	□			3.2	
□	□	□	□	□			4.1	
□	□	□	□	□			4.2	
□	□	□	□	□	□	□	1.1	N
■	□	□	□	□	□	□	1.2	
■	□	□	□	□	□	□	1.3	
■	□	□	□	□	□	□	1.4	
■	□	□	□	□	□	□	1.5	
□	□	□	□	□	□	□	1.6	
■	□	■	■	■			2.1	
■	□	■	■	■			2.2	
	□	■	■	■			2.3	
	□	■	■	■			2.4	
	□	■	■	■			2.5	
	□	■	■	■			2.6	
	□	■	■	■			2.7	
	□	■	■	■			2.8	
							3.1	S
							3.2	
							4.1	
							4.2	
							4.3	
							4.4	
	□						5.1	
							5.2	
							5.3	
□					□	□	1.1	
□					□	□	1.2	
					□	□	1.3	
		■	■	■			2.1	
		■	■	■	□	□	2.2	
					□	□	2.3	
					□	□	2.4	
					□	□	2.5	
					□	□	2.6	
	□	■	■				1.1	H
	□	□	□				1.2	
							1.3	
							1.4	
							1.5	

- 3 x D
- 5 x D
- 6 x D
- 8 x D
- 2-3.5 x D



Coolant-lubricant recommendation



Emulsion	Oil	Minimum quantity lubrication (MQL)	Dry / Pressurized air
----------	-----	------------------------------------	-----------------------

EF-Drill Modular STEEL		EF-Drill C STEEL
3 x D	5 x D	2-3.5 x D
406 - 409, 410	406 - 409, 411	412

- 3 x D
- 5 x D
- 6 x D
- 8 x D
- 2-3.5 x D

P	1.1	■	■	□		■	■	■
	2.1	■	■	□		■	■	■
	3.1	■	■	□		■	■	■
	4.1	■	■	□		■	■	■
	5.1	■	■	□		■	■	■
M	1.1	■	□			■		■
	2.1	■	□					
	3.1	■	□					
	4.1	■	□					
K	1.1	■		□	□	■		□
	1.2	■		□	□	■		□
	2.1	■		□	□	■		□
	2.2	■		□	□	■		■
	3.1	■		□	□	□		□
	3.2	■		□	□	□		□
	4.1	■		□	□	□		□
	4.2	■		□	□	□		□
N	1.1	■	□					□
	1.2	■	□					□
	1.3	■	□					□
	1.4	■	□					□
	1.5	■	□		□		□	□
	1.6	■	□					□
	2.1	■	□					■
	2.2	■	□					■
	2.3	■	□					■
	2.4	■	□					■
	2.5	■	□					■
	2.6	■	□					■
	2.7	■	□					■
	2.8	■	□					■
	3.1							
	3.2							
4.1								
4.2								
4.3								
4.4								
5.1				■				
5.2								
5.3								
S	1.1	■	□					
	1.2	■	□					
	1.3	■	□					
	2.1							
	2.2							■
	2.3							■
	2.4							
2.5								
2.6								
H	1.1	■	■	□	□			■
	1.2	■	■	□	□			□
	1.3							
	1.4							
	1.5							





142° NC Spot Drills	NC Spot / Chamfer Drills	Chamfer Mills	HSS Countersinks	Type
-	-	-	-	Drill depth
414	415	416	417	Page
■	■	■	■	1.1
■	■	■	■	2.1
■	□	■	□	3.1
■		■	□	4.1
■		□		5.1
□	□	□	□	1.1
□	□	□	□	2.1
□		□		3.1
□		□		4.1
■	■	■	■	1.1
■	■	■	■	1.2
■	■	■	■	2.1
□	□	□	□	2.2
□	□	□	□	3.1
□	□	□	□	3.2
□	□	■	□	4.1
□	□	□	□	4.2
□	□	□	□	1.1
□	□	□	□	1.2
□	□	□	□	1.3
□	□	□	□	1.4
□	□	□	□	1.5
□	□	□	□	1.6
□	□	□	□	2.1
□	□	□	□	2.2
□	□	□	□	2.3
□	□	□	□	2.4
□	□	□	□	2.5
□	□	□	□	2.6
□	□	□	□	2.7
□	□	□	□	2.8
□	□	□	□	3.1
□	□	□	□	3.2
□	□	□	□	4.1
□	□	□	□	4.2
□	□	□	□	4.3
□	□	□	□	4.4
□		□		5.1
		□		5.2
		□		5.3
□	□	□	□	1.1
		□		1.2
		□		1.3
□	□	□	□	2.1
□	□	□	□	2.2
□	□	□	□	2.3
□	□	□	□	2.4
□	□	□	□	2.5
□	□	□	□	2.6
□				1.1
				1.2
				1.3
				1.4
				1.5

- 3 x D
- 5 x D
- 6 x D
- 8 x D
- 2-3.5 x D





EF-Drill Micro
 STEEL
 6 x D

	Cutting speed v _c [SFM]			Feed per revolution f [inch/rev.]									
	D = 0.8 mm D = 0.031 inch			D = 1 mm D = 0.039 inch			D = 1.25 mm D = 0.049 inch						
	min.	rec.	max.	min.	rec.	max.	min.	rec.	max.	min.	rec.	max.	
P	1.1	262	295	328	.0008	.0010	.0012	.0012	.0014	.0016	.0016	.0018	.0020
	2.1	230	279	328	.0008	.0010	.0012	.0012	.0014	.0016	.0016	.0018	.0020
	3.1	197	213	230	.0004	.0006	.0008	.0008	.0010	.0012	.0012	.0014	.0016
	4.1	164	180	197	.0004	.0006	.0008	.0008	.0010	.0012	.0012	.0014	.0016
	5.1	148	164	180	.0004	.0006	.0008	.0008	.0010	.0012	.0012	.0014	.0016
M	1.1	131	157	180	.0002	.0003	.0004	.0004	.0005	.0006	.0008	.0009	.0010
	2.1	98	115	131	.0004	.0006	.0008	.0006	.0008	.0010	.0010	.0012	.0014
	3.1	98	115	131	.0002	.0003	.0004	.0004	.0005	.0006	.0008	.0009	.0010
	4.1	98	115	131	.0002	.0003	.0004	.0004	.0005	.0006	.0008	.0009	.0010
K	1.1	394	476	558	.0008	.0010	.0012	.0016	.0020	.0024	.0024	.0028	.0031
	1.2	394	476	558	.0008	.0010	.0012	.0016	.0020	.0024	.0024	.0028	.0031
	2.1	394	443	492	.0008	.0010	.0012	.0016	.0020	.0024	.0024	.0028	.0031
	2.2	295	344	394	.0004	.0006	.0008	.0012	.0016	.0020	.0020	.0024	.0028
	3.1	197	230	262	.0008	.0010	.0012	.0012	.0016	.0020	.0016	.0020	.0024
	3.2	197	230	262	.0004	.0006	.0008	.0008	.0012	.0016	.0012	.0016	.0020
	4.1	197	230	262	.0008	.0010	.0012	.0012	.0016	.0020	.0016	.0020	.0024
	4.2	197	230	262	.0004	.0006	.0008	.0008	.0012	.0016	.0012	.0016	.0020
N	1.1	328	459	591	.0012	.0014	.0016	.0016	.0018	.0020	.0020	.0022	.0024
	1.2	328	459	591	.0012	.0014	.0016	.0016	.0018	.0020	.0020	.0022	.0024
	1.3	328	459	591	.0012	.0014	.0016	.0016	.0018	.0020	.0020	.0022	.0024
	1.4	262	377	492	.0012	.0014	.0016	.0016	.0018	.0020	.0020	.0022	.0024
	1.5	262	377	492	.0008	.0010	.0012	.0012	.0014	.0016	.0016	.0018	.0020
	1.6	262	377	492	.0008	.0010	.0012	.0012	.0014	.0016	.0016	.0018	.0020
	2.1												
	2.2	394	443	492	.0004	.0008	.0012	.0008	.0012	.0016	.0012	.0016	.0020
	2.3	394	443	492	.0004	.0008	.0012	.0008	.0012	.0016	.0012	.0016	.0020
	2.4												
	2.5												
	2.6												
	2.7												
	2.8												
	3.1												
	3.2												
4.1													
4.2													
4.3													
4.4													
5.1													
5.2													
5.3													
S	1.1												
	1.2	66	82	98	.0004	.0006	.0008	.0004	.0006	.0008	.0010	.0012	.0014
	1.3	49	66	82	.0004	.0006	.0008	.0004	.0006	.0008	.0010	.0012	.0014
	2.1												
	2.2												
	2.3												
2.4													
2.5													
2.6													
H	1.1												
	1.2												
	1.3												
	1.4												
	1.5												



Cutting data

Please note that these data are standard values only.

- We recommend the standard values in bold print (**rec.**) for stable work conditions and for high-performance machine tools with sufficient speed capability.
- Correspondingly, the lower cutting speeds (**min.**) in connection with higher feed values (up to **max.**) should be used for machine tools with lower spindle speeds.
- For optimum workpiece conditions, and for machine tools with extremely high performance and high spindle speeds, the high cutting speeds (**max.**) in connection with possibly reduced feed values can be applied.

D = 1.5 mm D = 0.059 inch			D = 2 mm D = 0.079 inch			D = 2.5 mm D = 0.098 inch			D = 3 mm D = 0.118 inch			
Feed per revolution f [inch/rev.]												
min.	rec.	max.	min.	rec.	max.	min.	rec.	max.	min.	rec.	max.	
.0024	.0026	.0028	.0035	.0039	.0043	.0047	.0051	.0055	.0059	.0063	.0067	1.1
.0024	.0026	.0028	.0035	.0039	.0043	.0047	.0051	.0055	.0059	.0063	.0067	2.1
.0016	.0018	.0020	.0024	.0026	.0028	.0031	.0033	.0035	.0047	.0049	.0051	3.1
.0016	.0018	.0020	.0024	.0026	.0028	.0031	.0033	.0035	.0047	.0049	.0051	4.1
.0016	.0018	.0020	.0024	.0026	.0028	.0031	.0033	.0035	.0047	.0049	.0051	5.1
.0012	.0014	.0016	.0020	.0022	.0024	.0024	.0026	.0028	.0028	.0030	.0031	1.1
.0014	.0017	.0020	.0022	.0025	.0028	.0026	.0029	.0031	.0030	.0033	.0035	2.1
.0012	.0014	.0016	.0020	.0022	.0024	.0024	.0026	.0028	.0028	.0030	.0031	3.1
.0012	.0014	.0016	.0020	.0022	.0024	.0024	.0026	.0028	.0028	.0030	.0031	4.1
.0031	.0035	.0039	.0039	.0043	.0047	.0051	.0055	.0059	.0063	.0067	.0071	1.1
.0031	.0035	.0039	.0039	.0043	.0047	.0051	.0055	.0059	.0063	.0067	.0071	1.2
.0031	.0035	.0039	.0039	.0043	.0047	.0051	.0055	.0059	.0063	.0067	.0071	2.1
.0028	.0031	.0035	.0035	.0039	.0043	.0047	.0051	.0055	.0059	.0063	.0067	2.2
.0020	.0024	.0028	.0028	.0031	.0035	.0035	.0039	.0043	.0043	.0047	.0051	3.1
.0016	.0020	.0024	.0024	.0024	.0028	.0024	.0030	.0035	.0031	.0037	.0043	3.2
.0020	.0024	.0028	.0028	.0031	.0035	.0035	.0039	.0043	.0043	.0047	.0051	4.1
.0016	.0020	.0024	.0020	.0024	.0028	.0024	.0030	.0035	.0031	.0037	.0043	4.2
.0028	.0030	.0031	.0039	.0043	.0047	.0051	.0055	.0059	.0063	.0067	.0071	1.1
.0028	.0030	.0031	.0039	.0043	.0047	.0051	.0055	.0059	.0063	.0067	.0071	1.2
.0028	.0030	.0031	.0039	.0043	.0047	.0051	.0055	.0059	.0063	.0067	.0071	1.3
.0028	.0030	.0031	.0039	.0043	.0047	.0051	.0055	.0059	.0063	.0067	.0071	1.4
.0024	.0026	.0028	.0035	.0039	.0043	.0047	.0051	.0055	.0059	.0063	.0067	1.5
.0024	.0026	.0028	.0035	.0039	.0043	.0047	.0051	.0055	.0059	.0063	.0067	1.6
.0020	.0024	.0028	.0031	.0037	.0043	.0043	.0049	.0055	.0055	.0061	.0067	2.1
.0020	.0024	.0028	.0031	.0037	.0043	.0043	.0049	.0055	.0055	.0061	.0067	2.2
												2.3
												2.4
												2.5
												2.6
												2.7
												2.8
												3.1
												3.2
												4.1
												4.2
												4.3
												4.4
												5.1
												5.2
												5.3
.0012	.0016	.0020	.0016	.0020	.0024	.0022	.0026	.0030	.0026	.0030	.0033	1.1
.0012	.0016	.0020	.0016	.0020	.0024	.0022	.0026	.0030	.0026	.0030	.0033	1.2
												1.3
												2.1
												2.2
												2.3
												2.4
												2.5
												2.6
												1.1
												1.2
												1.3
												1.4
												1.5





EF-Drill STEEL
3 x D

EF-Drill STEEL
3 x D

EF-Drill STEEL
5 x D

EF-Drill STEEL
8 x D

EF-Drill C STEEL
2 - 3.5 x D

Cutting speed v_c [SFM]

min. rec. max. min. rec. max. min. rec. max. min. rec. max. min. rec. max.

P	1.1	328	394	459	459	525	656	459	525	656	394	459	525	459	525	656
	2.1	279	328	377	394	476	558	394	476	558	312	377	443	394	476	558
	3.1	230	279	328	328	394	459	328	394	459	295	328	377	328	394	459
	4.1	197	230	262	262	328	394	262	328	394	230	279	328	262	328	394
	5.1	148	180	213	197	230	262	197	230	262	164	197	230	197	230	262
M	1.1				197	262	328	197	262	328	180	230	295	197	262	328
	2.1															
	3.1															
	4.1															
K	1.1	394	492	591	427	525	623	427	525	623	377	459	541	427	525	623
	1.2	328	427	492	361	459	525	361	459	525	312	410	459	361	459	525
	2.1	328	427	525	361	459	558	361	459	558	312	410	492	361	459	558
	2.2	328	394	459	394	459	525	394	459	525	344	410	459	394	459	525
	3.1	230	262	295	230	295	328	230	295	328	197	262	295	230	295	328
	3.2	230	262	295	230	295	328	230	295	328	197	262	295	230	295	328
	4.1	361	427	492	394	459	525	394	459	525	344	410	459	394	459	525
	4.2	295	361	427	328	394	459	328	394	459	295	344	410	328	394	459
N	1.1	689	787	886	722	853	919	722	853	919	640	755	804	722	853	919
	1.2	689	787	886	722	853	919	722	853	919	640	755	804	722	853	919
	1.3	591	656	722	656	755	853	656	755	853	574	656	755	656	755	853
	1.4	591	656	722	656	755	853	656	755	853	574	656	755	656	755	853
	1.5	492	558	591	541	607	656	541	607	656	476	541	574	541	607	656
	1.6															
	2.1	361	427	525	377	443	558	377	443	558	328	394	492	377	443	558
	2.2	492	525	558	525	574	623	525	574	623	459	509	541	525	574	623
	2.3	591	689	787	623	722	820	623	722	820	541	640	722	623	722	820
	2.4	197	262	295	230	295	361	230	295	361	197	262	312	230	295	361
	2.5	295	361	459	394	525	591	394	525	591	361	459	525	394	525	591
	2.6	295	328	361	328	377	427	328	377	427	295	328	377	328	377	427
	2.7	164	180	197	197	213	230	197	213	230	164	180	197	197	213	230
	2.8	164	180	197	213	230	246	213	230	246	180	197	213	213	230	246
	3.1															
	3.2															
4.1																
4.2																
4.3																
4.4																
5.1	230	295	394													
5.2																
5.3																
S	1.1															
	1.2															
	1.3															
	2.1															
	2.2				60	80	100	60	80	100	60	80	100	60	80	100
	2.3				50	65	80	50	65	80	50	65	80	50	65	80
2.4																
2.5																
2.6																
H	1.1	98	115	131	115	131	148	115	131	148				115	131	148
	1.2	66	82	98	98	115	131	98	115	131			98	115	131	
	1.3															
	1.4															
	1.5															



Cutting data

Please note that these data are standard values only.

- We recommend the standard values in bold print (**rec.**) for stable work conditions and for high-performance machine tools with sufficient speed capability.
- Correspondingly, the lower cutting speeds (**min.**) in connection with higher feed values (up to **max.**) should be used for machine tools with lower spindle speeds.
- For optimum workpiece conditions, and for machine tools with extremely high performance and high spindle speeds, the high cutting speeds (**max.**) in connection with possibly reduced feed values can be applied.

EF-Drill-STEEL 8 x D:

- Preparatory centering with a pilot drill is recommended.
- Reduce the recommended feed per revolution value f [inch/rev.] by 15%!

D = 3 mm D = 0.118 inch			D = 5 mm D = 0.197 inch			D = 8 mm D = 0.315 inch			D = 10 mm D = 0.394 inch			D = 12 mm D = 0.472 inch			D = 16 mm D = 0.630 inch			D = 20 mm D = 0.787 inch					
Feed per revolution f [inch/rev.]																							
min.	rec.	max.	min.	rec.	max.	min.	rec.	max.	min.	rec.	max.	min.	rec.	max.	min.	rec.	max.	min.	rec.	max.	min.	rec.	max.
.0031	.0043	.0051	.0043	.0059	.0075	.0055	.0071	.0098	.0079	.0094	.0114	.0087	.0098	.0126	.0098	.0122	.0150	.0114	.0138	.0165		1.1	
.0031	.0039	.0047	.0035	.0043	.0055	.0059	.0071	.0083	.0067	.0083	.0094	.0079	.0094	.0106	.0094	.0110	.0126	.0110	.0126	.0142		2.1	
.0031	.0039	.0047	.0035	.0043	.0055	.0059	.0071	.0083	.0067	.0083	.0094	.0079	.0094	.0106	.0094	.0110	.0126	.0110	.0126	.0142		3.1	
.0024	.0031	.0039	.0031	.0039	.0055	.0047	.0063	.0071	.0059	.0071	.0083	.0063	.0079	.0094	.0071	.0094	.0118	.0087	.0110	.0134		4.1	
.0012	.0024	.0031	.0024	.0031	.0039	.0039	.0047	.0059	.0043	.0055	.0067	.0055	.0063	.0071	.0067	.0079	.0091	.0083	.0094	.0106		5.1	
.0016	.0024	.0031	.0028	.0035	.0039	.0035	.0043	.0051	.0043	.0055	.0067	.0059	.0075	.0087	.0071	.0087	.0102	.0087	.0102	.0118		1.1	
																						2.1	
																						3.1	
																						4.1	
.0047	.0063	.0079	.0067	.0087	.0102	.0094	.0118	.0134	.0106	.0130	.0154	.0118	.0142	.0181	.0138	.0161	.0205	.0154	.0177	.0220		1.1	
.0039	.0051	.0063	.0059	.0075	.0091	.0079	.0102	.0126	.0091	.0114	.0138	.0102	.0134	.0165	.0126	.0150	.0197	.0142	.0165	.0213		1.2	
.0039	.0055	.0067	.0059	.0079	.0094	.0083	.0106	.0130	.0094	.0118	.0142	.0106	.0138	.0169	.0130	.0154	.0201	.0146	.0169	.0217		2.1	
.0035	.0047	.0059	.0051	.0067	.0083	.0063	.0087	.0110	.0071	.0091	.0114	.0079	.0106	.0126	.0094	.0122	.0146	.0110	.0138	.0161		2.2	
.0039	.0047	.0055	.0051	.0059	.0075	.0067	.0083	.0102	.0083	.0102	.0122	.0106	.0126	.0146	.0126	.0146	.0161	.0142	.0161	.0177		3.1	
.0039	.0047	.0055	.0051	.0059	.0075	.0067	.0083	.0102	.0083	.0102	.0122	.0106	.0126	.0146	.0126	.0146	.0161	.0142	.0161	.0177		3.2	
.0039	.0051	.0063	.0055	.0067	.0083	.0071	.0094	.0118	.0087	.0118	.0134	.0094	.0126	.0157	.0110	.0150	.0181	.0126	.0165	.0197		4.1	
.0035	.0047	.0059	.0047	.0063	.0079	.0063	.0083	.0106	.0079	.0106	.0122	.0087	.0114	.0142	.0106	.0134	.0165	.0122	.0150	.0181		4.2	
.0047	.0055	.0067	.0071	.0087	.0098	.0094	.0110	.0126	.0118	.0138	.0157	.0150	.0169	.0189	.0177	.0205	.0236	.0193	.0220	.0252		1.1	
.0047	.0055	.0067	.0071	.0087	.0098	.0094	.0110	.0126	.0118	.0138	.0157	.0150	.0169	.0189	.0177	.0205	.0236	.0193	.0220	.0252		1.2	
.0047	.0055	.0067	.0071	.0087	.0098	.0094	.0110	.0126	.0118	.0138	.0157	.0150	.0169	.0189	.0177	.0205	.0236	.0193	.0220	.0252		1.3	
.0047	.0055	.0067	.0071	.0087	.0098	.0094	.0110	.0126	.0118	.0138	.0157	.0150	.0169	.0189	.0177	.0205	.0236	.0193	.0220	.0252		1.4	
.0047	.0055	.0063	.0063	.0071	.0087	.0087	.0102	.0118	.0114	.0134	.0150	.0138	.0154	.0173	.0157	.0177	.0197	.0173	.0193	.0213		1.5	
																						1.6	
.0028	.0035	.0055	.0035	.0047	.0063	.0051	.0063	.0071	.0063	.0075	.0091	.0071	.0087	.0106	.0083	.0102	.0118	.0098	.0118	.0134		2.1	
.0024	.0035	.0043	.0047	.0055	.0063	.0063	.0079	.0094	.0079	.0094	.0110	.0094	.0110	.0126	.0110	.0130	.0146	.0126	.0146	.0161		2.2	
.0047	.0055	.0063	.0055	.0063	.0079	.0079	.0098	.0118	.0094	.0118	.0150	.0110	.0142	.0161	.0126	.0150	.0177	.0142	.0165	.0193		2.3	
.0020	.0028	.0031	.0028	.0035	.0043	.0047	.0055	.0063	.0055	.0063	.0079	.0063	.0071	.0087	.0071	.0079	.0098	.0087	.0094	.0114		2.4	
.0024	.0031	.0039	.0031	.0047	.0055	.0055	.0071	.0079	.0063	.0079	.0094	.0079	.0091	.0102	.0087	.0098	.0118	.0102	.0114	.0134		2.5	
.0028	.0035	.0043	.0035	.0043	.0051	.0059	.0067	.0079	.0071	.0083	.0091	.0083	.0094	.0106	.0094	.0110	.0126	.0110	.0126	.0142		2.6	
.0012	.0016	.0020	.0016	.002	.0028	.0031	.0035	.0039	.0035	.0039	.0047	.0039	.0047	.0055	.0047	.0055	.0063	.0063	.0071	.0079		2.7	
.0012	.0016	.0020	.0016	.002	.0028	.0031	.0035	.0039	.0035	.0039	.0047	.0039	.0047	.0055	.0047	.0055	.0063	.0063	.0071	.0079		2.8	
																						3.1	
																						3.2	
																						4.1	
																						4.2	
																						4.3	
																						4.4	
.0039	.0047	.0055	.0047	.0055	.0063	.0055	.0063	.0071	.0063	.0075	.0083	.0071	.0083	.0094	.0079	.0094	.0110	.0094	.0110	.0126		5.1	
																						5.2	
																						5.3	
																						1.1	
																						1.2	
																						1.3	
.0012	.0016	.0020	.0020	.0025	.0031	.0024	.0029	.0035	.0031	.0037	.0043	.0039	.0045	.0051	.0047	.0057	.0067	.0059	.0071	.0083		2.1	
.0012	.0016	.0020	.0020	.0025	.0031	.0024	.0029	.0035	.0031	.0037	.0043	.0039	.0045	.0051	.0047	.0057	.0067	.0059	.0071	.0083		2.2	
																						2.3	
																						2.4	
																						2.5	
																						2.6	
.0016	.0024	.0031	.0024	.0028	.0031	.0039	.0047	.0055	.0047	.0055	.0063	.0055	.0063	.0071	.0063	.0071	.0079	.0079	.0087	.0094		1.1	
.0012	.0020	.0024	.0016	.0024	.0028	.0031	.0039	.0047	.0039	.0047	.0055	.0047	.0055	.0063	.0055	.0063	.0071	.0071	.0079	.0087		1.2	
																						1.3	
																						1.4	
																						1.5	





EF-Drill Modular
STEEL
3 x D

EF-Drill Modular
STEEL
5 x D

Cutting speed v_c [SFM]

		min.	rec.	max.	min.	rec.	max.
P	1.1	328	459	459	328	459	459
	2.1	295	377	427	295	377	427
	3.1	230	328	361	230	328	361
	4.1	197	262	328	197	262	328
	5.1	164	197	230	164	197	230
M	1.1	131	164	197	131	164	197
	2.1						
	3.1						
	4.1						
K	1.1	328	394	541	328	394	541
	1.2	279	410	459	279	410	459
	2.1	279	410	492	279	410	492
	2.2	295	410	459	295	410	459
	3.1	164	230	295	164	230	295
	3.2	164	230	295	164	230	295
	4.1	295	410	459	295	410	459
	4.2	295	295	410	295	295	410
N	1.1						
	1.2						
	1.3						
	1.4	328	492	656	328	492	656
	1.5	262	394	525	262	394	525
	1.6						
	2.1						
	2.2						
	2.3						
	2.4						
	2.5						
	2.6						
	2.7						
	2.8						
	3.1						
	3.2						
4.1							
4.2							
4.3							
4.4							
5.1							
5.2							
5.3							
S	1.1						
	1.2						
	1.3						
	2.1						
	2.2						
	2.6						
H	1.1						
	1.2						
	1.3						
	1.4						
	1.5						

3 x D
 5 x D
 6 x D
 8 x D
 2-3.5 x D



Cutting data

Please note that these data are standard values only.

- We recommend the standard values in bold print (**rec.**) for stable work conditions and for high-performance machine tools with sufficient speed capability.
- Correspondingly, the lower cutting speeds (**min.**) in connection with higher feed values (up to **max.**) should be used for machine tools with lower spindle speeds.
- For optimum workpiece conditions, and for machine tools with extremely high performance and high spindle speeds, the high cutting speeds (**max.**) in connection with possibly reduced feed values can be applied.

D = 14 mm D = 0.551 inch			D = 16 mm D = 0.630 inch			D = 20 mm D = 0.787 inch			D = 24 mm D = 0.945 inch			D = 28 mm D = 1.102 inch			D = 32 mm D = 1.259 inch			
Feed per revolution f [inch/rev.]																		
min.	rec.	max.	min.	rec.	max.	min.	rec.	max.	min.	rec.	max.	min.	rec.	max.	min.	rec.	max.	
.0059	.0087	.0110	.0071	.0098	.0122	.0083	.0110	.0134	.0102	.0130	.0154	.0118	.0146	.0169	.0134	.0161	.0185	1.1
.0063	.0091	.0118	.0075	.0102	.013	.0087	.0114	.0142	.0106	.0134	.0161	.0122	.0150	.0177	.0138	.0165	.0193	2.1
.0087	.0106	.0122	.0098	.0118	.0134	.0110	.0130	.0146	.0130	.0150	.0165	.0146	.0165	.0181	.0161	.0181	.0197	3.1
.0067	.0087	.0106	.0079	.0098	.0118	.0091	.0110	.0130	.0110	.0130	.0150	.0126	.0146	.0165	.0142	.0161	.0181	4.1
.0063	.0083	.0102	.0075	.0094	.0114	.0087	.0106	.0126	.0106	.0126	.0146	.0122	.0142	.0161	.0138	.0157	.0177	5.1
.0051	.0067	.0079	.0059	.0075	.0087	.0067	.0083	.0094	.0079	.0094	.0106	.0087	.0102	.0114	.0094	.0110	.0122	1.1
																		2.1
																		3.1
																		4.1
.0091	.0130	.0169	.0122	.0161	.0201	.0154	.0193	.0232	.0193	.0232	.0272	.0224	.0264	.0303	.0256	.0295	.0335	1.1
.0075	.0118	.0157	.0106	.0150	.0189	.0138	.0181	.0220	.0177	.0220	.0260	.0209	.0252	.0291	.0240	.0283	.0323	1.2
.0083	.0122	.0157	.0114	.0154	.0189	.0146	.0185	.0220	.0185	.0224	.0260	.0217	.0256	.0291	.0248	.0287	.0323	2.1
.0067	.0110	.0150	.0098	.0142	.0181	.0130	.0173	.0213	.0169	.0213	.0252	.0201	.0244	.0283	.0232	.0276	.0315	2.2
.0059	.0094	.0130	.0091	.0126	.0161	.0122	.0157	.0193	.0161	.0197	.0232	.0193	.0228	.0264	.0224	.0260	.0295	3.1
.0059	.0094	.0130	.0091	.0126	.0161	.0122	.0157	.0193	.0161	.0197	.0232	.0193	.0228	.0264	.0224	.0260	.0295	3.2
.0055	.0087	.0114	.0087	.0118	.0146	.0118	.0150	.0177	.0157	.0189	.0217	.0189	.0220	.0248	.0220	.0252	.0280	4.1
.0051	.0079	.0106	.0083	.0110	.0138	.0114	.0142	.0169	.0154	.0181	.0209	.0185	.0213	.0240	.0217	.0244	.0272	4.2
																		1.1
																		1.2
																		1.3
.0118	.0138	.0157	.0138	.0157	.0177	.0157	.0177	.0197	.0177	.0197	.0217	.0197	.0217	.0236	.0217	.0236	.0256	1.4
.0157	.0177	.0197	.0177	.0197	.0217	.0197	.0217	.0236	.0217	.0236	.0256	.0236	.0256	.0276	.0256	.0276	.0295	1.5
																		1.6
																		2.1
																		2.2
																		2.3
																		2.4
																		2.5
																		2.6
																		2.7
																		2.8
																		3.1
																		3.2
																		4.1
																		4.2
																		4.3
																		4.4
																		5.1
																		5.2
																		5.3
																		1.1
																		1.2
																		1.3
																		2.1
																		2.2
																		2.3
																		2.4
																		2.5
																		2.6
																		1.1
																		1.2
																		1.3
																		1.4
																		1.5





EF-Drill
VA
3 x D

EF-Drill
VA
5 x D

Cutting speed v_c [SFM]

		min.	rec.	max.	min.	rec.	max.
P	1.1						
	2.1						
	3.1						
	4.1						
	5.1						
M	1.1	197	262	328	197	262	328
	2.1	131	164	197	131	164	197
	3.1	115	131	148	115	131	148
	4.1	98	115	131	98	115	131
K	1.1						
	1.2						
	2.1						
	2.2						
	3.1						
	3.2						
	4.1						
	4.2						
N	1.1	722	853	919	722	853	919
	1.2	722	853	919	722	853	919
	1.3	656	755	853	656	755	853
	1.4						
	1.5						
	1.6						
	2.1						
	2.2						
	2.3						
	2.4						
	2.5						
	2.6						
	2.7						
	2.8						
	3.1						
	3.2						
	4.1						
4.2							
4.3							
4.4							
5.1							
5.2							
5.3							
S	1.1	148	180	213	148	180	213
	1.2	98	148	180	98	148	180
	1.3	98	115	131	98	115	131
	2.1						
	2.2	33	66	98	33	66	98
	2.3	50	65	80	50	65	80
2.4	98	148	180	98	148	180	
2.5							
2.6	98	115	131	98	115	131	
H	1.1						
	1.2						
	1.3						
	1.4						
	1.5						

3 x D
 5 x D
 6 x D
 8 x D
 2-3.5 x D





Cutting data

Please note that these data are standard values only.

- We recommend the standard values in bold print (**rec.**) for stable work conditions and for high-performance machine tools with sufficient speed capability.
- Correspondingly, the lower cutting speeds (**min.**) in connection with higher feed values (up to **max.**) should be used for machine tools with lower spindle speeds.
- For optimum workpiece conditions, and for machine tools with extremely high performance and high spindle speeds, the high cutting speeds (**max.**) in connection with possibly reduced feed values can be applied.

		NC Spot / Chamfer Drills					NC Spot Drills						
		Cutting speed v _c [SFM]					Feed per revolution f [inch/rev.]						
		D ≤ 6 mm			D > 6 mm			D ≤ 1/4			D > 1/4		
		min.	rec.	max.	min.	rec.	max.	min.	rec.	max.	min.	rec.	max.
P	1.1	197	230	279	328	394	459	.0020	.0028	.0035	.0031	.0039	.0047
	2.1	164	197	230	279	328	377	.0020	.0028	.0035	.0031	.0039	.0047
	3.1	131	164	197	230	279	328	.0020	.0028	.0035	.0031	.0039	.0047
	4.1				197	230	262	.0020	.0024	.0028	.0031	.0035	.0039
	5.1				148	180	213	.0020	.0024	.0028	.0031	.0035	.0039
M	1.1	115	164	197	197	262	328	.0020	.0024	.0028	.0031	.0035	.0039
	2.1	82	98	115	131	164	197	.0020	.0024	.0028	.0031	.0035	.0039
	3.1				115	131	148	.0020	.0024	.0028	.0031	.0035	.0039
	4.1												
K	1.1	230	295	361	394	492	591	.0020	.0039	.0059	.0031	.0047	.0063
	1.2	197	262	295	328	427	492	.0020	.0039	.0059	.0031	.0047	.0063
	2.1	197	262	312	328	427	525	.0020	.0031	.0043	.0031	.0043	.0055
	2.2	197	230	279	328	394	459	.0020	.0031	.0043	.0031	.0043	.0055
	3.1	131	164	180	230	262	295	.0020	.0028	.0035	.0031	.0039	.0047
	3.2				230	262	295	.0020	.0028	.0035	.0031	.0039	.0047
	4.1	213	262	295	361	427	492	.0020	.0031	.0043	.0031	.0043	.0055
	4.2	180	213	262	295	361	427	.0020	.0031	.0043	.0031	.0043	.0055
N	1.1	410	476	525	689	787	886	.0031	.0047	.0063	.0043	.0059	.0071
	1.2	410	476	525	689	787	886	.0031	.0047	.0063	.0043	.0059	.0071
	1.3	361	394	427	591	656	722	.0024	.0039	.0055	.0035	.0051	.0063
	1.4	361	394	427	591	656	722	.0031	.0047	.0063	.0043	.0059	.0071
	1.5	295	328	361	492	558	591	.0031	.0047	.0063	.0043	.0059	.0071
	1.6												
	2.1	213	262	312	361	427	525	.0024	.0031	.0039	.0035	.0043	.0051
	2.2	295	312	328	492	525	558	.0024	.0031	.0039	.0035	.0043	.0051
	2.3	361	410	476	591	689	787	.0031	.0039	.0047	.0043	.0051	.0059
	2.4	115	164	180	197	262	295	.0020	.0028	.0035	.0031	.0039	.0047
	2.5	180	213	279	295	361	459	.0020	.0028	.0035	.0031	.0039	.0047
	2.6	180	197	213	295	328	361	.0031	.0039	.0047	.0043	.0051	.0059
	2.7				164	180	197	.0020	.0028	.0035	.0031	.0039	.0047
	2.8				164	180	197	.0020	.0028	.0035	.0031	.0039	.0047
	3.1	180	213	279	295	361	459	.0020	.0028	.0035	.0031	.0039	.0047
	3.2	115	164	180	197	262	295	.0020	.0028	.0035	.0031	.0039	.0047
4.1	262	279	295	427	459	492	.0016	.0024	.0031	.0028	.0035	.0043	
4.2	295	312	328	492	525	558	.0016	.0024	.0031	.0028	.0035	.0043	
4.3													
4.4													
5.1				230	295	394	.0024	.0031	.0039	.0035	.0043	.0051	
5.2													
5.3													
S	1.1	82	98	115	131	164	197	.0020	.0024	.0028	.0031	.0035	.0039
	1.2				82	131	164	.0020	.0024	.0028	.0031	.0035	.0039
	1.3												
	2.1												
	2.2	16	33	66	33	66	98	.0020	.0024	.0028	.0031	.0035	.0039
	2.3												
2.4				98	148	180	.0020	.0024	.0028	.0031	.0035	.0039	
2.5													
2.6				98	115	131	.0020	.0024	.0028	.0031	.0035	.0039	
H	1.1				98	115	131	.0020	.0024	.0028	.0031	.0035	.0039
	1.2												
	1.3												
	1.4												
	1.5												



Cutting data

Please note that these data are standard values only.

- We recommend the standard values in bold print (**rec.**) for stable work conditions and for high-performance machine tools with sufficient speed capability.
- Correspondingly, the lower cutting speeds (**min.**) in connection with higher feed values (up to **max.**) should be used for machine tools with lower spindle speeds.
- For optimum workpiece conditions, and for machine tools with extremely high performance and high spindle speeds, the high cutting speeds (**max.**) in connection with possibly reduced feed values can be applied.



HSS Countersinks

HSS Countersinks
TiN

	Cutting speed v_c [SFM]						Feed per revolution f [inch/rev.]			
	min.	rec.	max.	min.	rec.	max.	min.	rec.	max.	
P	1.1	33	49	66	66	82	98	.0012	.0020	.0028
	2.1	16	33	33	33	49	66	.0012	.0020	.0028
	3.1	16	16	33	26	39	49	.0008	.0012	.0016
	4.1				16	26	33	.0008	.0012	.0016
	5.1									
M	1.1	13	16	20	20	26	33	.0008	.0012	.0016
	2.1	7	13	20	13	20	33	.0008	.0012	.0016
	3.1									
	4.1									
K	1.1	49	59	69	82	98	115	.0024	.0031	.0039
	1.2	30	39	49	49	66	82	.0024	.0031	.0039
	2.1	23	26	33	39	46	52	.0024	.0031	.0039
	2.2	20	23	26	33	39	46	.0024	.0031	.0039
	3.1	16	20	13	26	33	20	.0028	.0028	.0035
	3.2									
	4.1	16	20	23	26	33	39	.0031	.0031	.0039
	4.2	13	16	20	20	26	33	.0031	.0031	.0039
N	1.1	66	98	131	98	164	230	.0020	.0024	.0028
	1.2	33	82	115	66	131	197	.0020	.0024	.0028
	1.3	16	66	98	33	98	164	.0020	.0024	.0028
	1.4	33	49	82	49	82	131	.0020	.0024	.0028
	1.5	16	33	66	33	66	98	.0020	.0024	.0028
	1.6									
	2.1	16	66	98	33	98	164	.0028	.0031	.0035
	2.2	33	82	115	66	131	197	.0028	.0031	.0035
	2.3	66	115	131	115	160	213	.0028	.0031	.0035
	2.4	16	33	66	33	66	98	.0024	.0028	.0031
	2.5	16	66	98	33	98	164	.0024	.0028	.0031
	2.6	16	33	66	33	66	98	.0028	.0031	.0035
	2.7									
	2.8									
	3.1	82	115	164	131	197	262	.0035	.0039	.0043
	3.2	66	98	131	98	164	230	.0035	.0039	.0043
4.1	82	131	164	148	213	279	.0016	.0020	.0024	
4.2	98	131	180	164	230	295	.0016	.0020	.0024	
4.3										
4.4										
5.1										
5.2										
5.3										
S	1.1	10	16	20	16	26	33	.0012	.0016	.0020
	1.2									
	1.3									
	2.1									
	2.2									
	2.3									
	2.4									
2.5										
2.6										
H	1.1									
	1.2									
	1.3									
	1.4									
	1.5									

- 3 x D
- 5 x D
- 6 x D
- 8 x D
- 2-3.5 x D



- Product Finder
- v_c / f
- STEEL
- VA
- Accessories
- Tech. Info

- 3 x D
- 5 x D
- 6 x D
- 8 x D
- 2-3.5 x D



Metric Shank

Carbide

TIALN T99

new

R30

2 Flutes

2FF



140°

IT9-IT10



DIN 6535

HA

STEEL
Steel & Universal Applications

Product Finder

V_c / f

STEEL

VA

Accessories

Tech. Info

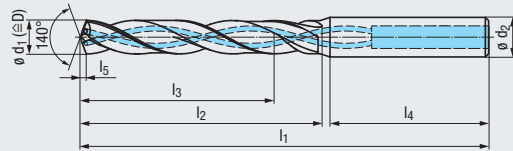

Applications – Material

P 1.1-5.1 M 1.1-4.1 K 1.1-4.2

N 1.1-6 N 2.2-3 S 1.2-3

Drill Depth

6 x D

Tool Identification

TE213324

Nominal Size ø d ₁ k5		Taps	Roll Form Taps	mm						Dimens. ID	EF-Drill Micro-STEEL HA-1K-2FF TIALN-T99
inch	mm			l ₁	l ₂	l ₃	l ₄	l ₅	ø d ₂		
0.0295	0.75	M1		51.5	6.8	4.5	40	0.105	3	.0075	●
0.0315	0.80	M1x0.2		51.5	7.2	4.8	40	0.112	3	.0080	●
0.0335	0.85	M1.1		51.5	7.7	5.1	40	0.119	3	.0085	●
0.0354	0.90	M1.1x.2	M1	51.5	8.1	5.4	40	0.126	3	.0090	●
0.0374	0.95	M1.2		51.5	8.6	5.7	40	0.132	3	.0095	●
0.0394	1.00	M1.2x0.2	M1.1	55	9	6	40	0.139	4	.0100	●
0.0433	1.10	M1.4	M1.2	55	9.9	6.6	40	0.153	4	.0110	●
0.0472	1.20	M1.4x0.2		55	10.8	7.2	40	0.167	4	.0120	●
0.0492	1.25	M1.6		55	11.3	7.5	40	0.174	4	.0125	●
0.0504	1.28		M1.4	55	11.3	7.7	40	0.178	4	.0128	●
0.0512	1.30	MJ1.6x0.35		57	11.7	7.8	40	0.181	4	.0130	●
0.0531	1.35	M1.7		57	12.2	8.1	40	0.188	4	.0135	●
0.0551	1.40	M1.6x0.2		57	12.6	8.4	40	0.195	4	.0140	●
0.0571	1.45	M1.8		57	13	8.7	40	0.202	4	.0145	●
0.0579	1.47		M1.6	57	13	8.8	40	0.202	4	.0147	●
0.0591	1.50			57	13.5	9	40	0.209	4	.0150	●
0.0618	1.57		M1.7	59	14	9.4	40	0.219	4	.0157	●
0.0630	1.60	M2 / M1.8x0.2		59	14.4	9.6	40	0.223	4	.0160	●
0.0657	1.67		M1.8	59	14.9	10	40	0.233	4	.0167	●
0.0669	1.70			59	15.3	10.2	40	0.237	4	.0170	●
0.0689	1.75	M2.2 / M2x0.25		59	15.8	10.5	40	0.244	4	.0175	●
0.0709	1.80			61	16.2	10.8	40	0.251	4	.0180	●
0.0728	1.85		M2	61	16.7	11.1	40	0.258	4	.0185	●
0.0748	1.90	M2.3	M2x0.25	61	17.1	11.4	40	0.265	4	.0190	●
0.0768	1.95	M2.2x0.25 / M2.3x0.35		61	17.6	11.7	40	0.272	4	.0195	●
0.0787	2.00			63	18	12	40	0.279	4	.0200	●
0.0799	2.03		M2.2	63	18	12.2	40	0.283	4	.0203	●
0.0807	2.05	M2.5 / M2.3x0.25		63	18.5	12.3	40	0.286	4	.0205	●
0.0827	2.10	MJ2.5x0.45	M2.2x0.25	63	18.9	12.6	40	0.293	4	.0210	●
0.0846	2.15	M2.6 / M2.5x0.35	M2.3	63	19.4	12.9	40	0.300	4	.0215	●
0.0866	2.20		M2.3x0.25	63	19.8	13.2	40	0.307	4	.0220	●
0.0906	2.30			65	20.7	13.8	40	0.321	4	.0230	●
0.0917	2.33		M2.5	65	21.2	14	40	0.325	4	.0233	●
0.0945	2.40		M2.5x0.25	65	21.6	14.4	40	0.335	4	.0240	●
0.0957	2.43		M2.6	65	21.6	14.6	40	0.339	4	.0243	●
0.0984	2.50	M3	M2.6x0.25	65	22.5	15	40	0.349	4	.0250	●
0.1024	2.60	MJ3x0.5		66.5	23.4	15.6	40	0.363	4	.0260	●
0.1043	2.65	M3x0.35		66.5	23.9	15.9	40	0.370	4	.0265	●
0.1063	2.70			66.5	24.3	16.2	40	0.377	4	.0270	●
0.1102	2.80		M3	68.5	25.2	16.8	40	0.390	4	.0280	●
0.1142	2.90	M3.5	M3x0.25	68.5	26.1	17.4	40	0.404	4	.0290	●
0.1181	3.00	M3.5x0.5 / MJ3.5x0.6		73	27	18	40	0.418	4	.0300	●

● = In stock
★ = Allow 7 days for delivery

- Product Finder
- v_c / f
- STEEL
- VA
- Accessories
- Tech. Info

Metric Shank

Carbide

TIALN
T14

DIN
6537 K

R30

2 Flutes

2FF

140°

IT9-IT10

DIN 6535
HA
HE

Stub Length

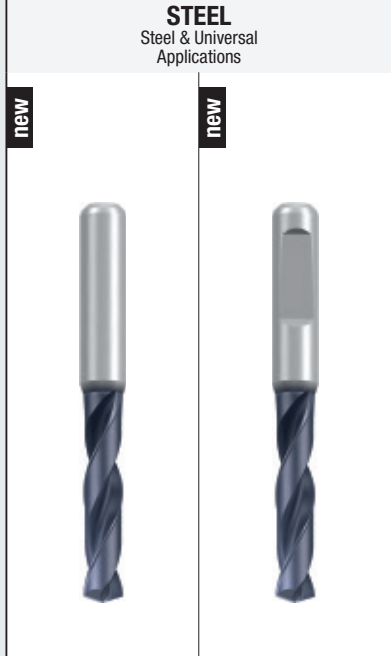
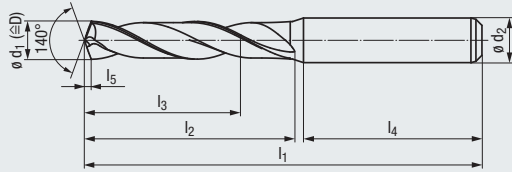

Applications – Material

P	1.1-5.1	K	1.1-4.2	N	1.1-5
N	2.1-8	N	5.1	H	1.1-2

Drill Depth

3 x D

Tool Identification

										TA103324		TA403324		
Nominal Size ø d ₁ m7				Taps	Roll Form Taps	mm					Dimens. ID	EF-Drill-STEEL DIN6537K-HA AK-2FF TIALN-T14	EF-Drill-STEEL DIN6537K-HE AK-2FF TIALN-T14	
inch	Fraction	Wire letter	mm			l ₁	l ₂	l ₃	l ₄	l ₅	ø d ₂ h6			
0.1102			2.800	#6-32UNC	M3	57	16	11	36	0.6	6	.0280	●	★
0.1142			2.900	#6-32UNJC	#5-40UNC	57	16	11	36	0.6	6	.0290	●	★
0.1150			2.920		#5-44UNF	57	16	11	36	0.6	6	.0292	●	★
0.1181			3.000	#6-40UNF		62	20	14	36	0.6	6	.0300	●	★
0.1220			3.100	STI-#4-40		62	20	14	36	0.6	6	.0310	●	★
0.1240			3.150	M3.5x0.35	#6-32UNC	62	20	14	36	0.7	6	.0315	●	★
0.1250	1/8		3.175			62	20	14	36	0.7	6	.0318	●	★
0.1260			3.200	BSW ⁵ /32-32	#6-40UNF	62	20	14	36	0.7	6	.0320	●	★
0.1280			3.250		M3.5	62	20	14	36	0.7	6	.0325	●	★
0.1299			3.300	M4		62	20	14	36	0.7	6	.0330	●	★
0.1331			3.380		M3.5x0.35	62	20	14	36	0.7	6	.0338	●	★
0.1339			3.400	MJ4x0.7		62	20	14	36	0.7	6	.0340	●	★
0.1378			3.500	#8-32UNC		62	20	14	36	0.7	6	.0350	●	★
0.1406	9/64	#28	3.571			62	20	14	36	0.7	6	.0357	●	★
0.1417			3.600	#8-36UNJF		62	20	14	36	0.7	6	.0360	●	★
0.1457			3.700	M4.5	M4	62	20	14	36	0.8	6	.0370	●	★
0.1496		#25	3.800	STI-#6-32	#8-32UNC	66	24	17	36	0.8	6	.0380	●	★
0.1516			3.850		#8-36UNF	66	24	17	36	0.8	6	.0385	●	★
0.1535			3.900	#10-24UNC		66	24	17	36	0.8	6	.0390	●	★
0.1563	5/32		3.970			66	24	17	36	0.8	6	.0397	●	★
0.1575			4.000	M4.5x0.5		66	24	17	36	0.8	6	.0400	●	★
0.1590		#21	4.038			66	24	17	36	0.8	6	.0404	●	★
0.1614			4.100	#10-32UNF		66	24	17	36	0.8	6	.0410	●	★
0.1654			4.200	M5 / STI-M4	M4.5	66	24	17	36	0.9	6	.0420	●	★
0.1693		#18	4.300	MJ5x0.8		66	24	17	36	0.9	6	.0430	●	★
0.1713			4.350		#10-24UNC	66	24	17	36	0.9	6	.0435	●	★
0.1719	11/64		4.366			66	24	17	36	0.9	6	.0437	●	★
0.1732			4.400	M5x0.75		66	24	17	36	0.9	6	.0440	●	★
0.1752			4.450		#10-32UNF	66	24	17	36	0.9	6	.0445	●	★
0.1772			4.500	#12-24UNC		66	24	17	36	0.9	6	.0450	●	★
0.1811			4.600	#12-28UNF		66	24	17	36	0.9	6	.0460	●	★
0.1831			4.650	#12-24UNJC	M5	66	24	17	36	0.9	6	.0465	●	★
0.1850		#13	4.700	LK-UNC#12-24		66	24	17	36	1.0	6	.0470	●	★
0.1875	3/16		4.763	#12-28UNJF		66	28	20	36	1.0	6	.0476	●	★
0.1890		#12	4.800	#12-32UNEF	M5x0.5 / STI-M5	66	28	20	36	1.0	6	.0480	●	★
0.1929			4.900			66	28	20	36	1.0	6	.0490	●	★
0.1969			5.000	M6	#12-24UNC	66	28	20	36	1.0	6	.0500	●	★
0.2008			5.100	MJ6x1	#12-28UNF	66	28	20	36	1.0	6	.0510	●	★
0.2010		#7	5.106			66	28	20	36	1.0	6	.0511	●	★
0.2031	13/64		5.159			66	28	20	36	1.0	6	.0516	●	★
0.2047			5.200	1/4-20UNC		66	28	20	36	1.0	6	.0520	●	★
0.2087			5.300	1/4-20UNJC		66	28	20	36	1.1	6	.0530	●	★
0.2126			5.400			66	28	20	36	1.1	6	.0540	●	★
0.2130		#3	5.410			66	28	20	36	1.1	6	.0541	●	★

Metric Shank

Stub Length

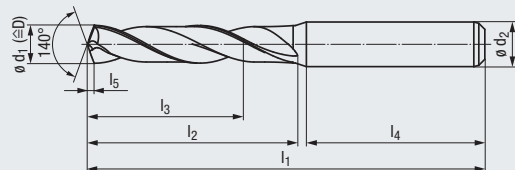

Carbide **TIALN T14**

DIN 6537 K **R30**

2 Flutes **2FF**

140° **IT9-IT10**

DIN 6535
HA HE

STEEL
Steel & Universal Applications

new **new**

Product Finder
Vc / f
STEEL
VA
Accessories
Tech. Info

Applications – Material

P	1.1-5.1	K	1.1-4.2	N	1.1-5
N	2.1-8	N	5.1	H	1.1-2

Drill Depth **3 x D**

Tool Identification													TA103324	TA403324
Nominal Size ø d ₁ m7				Taps	Roll Form Taps	mm						Dimens. ID	EF-Drill-STEEL DIN6537K-HA AK-2FF TIALN-T14	EF-Drill-STEEL DIN6537K-HE AK-2FF TIALN-T14
inch	Fraction	Wire letter	mm			l ₁	l ₂	l ₃	l ₄	l ₅	ø d ₂ h6			
0.2165			5.500	1/4-28 UNF		66	28	20	36	1.1	6	.0550	●	★
0.2187	7/32		5.556	1/4-28 UNJF		66	28	20	36	1.1	6	.0556	●	★
0.2205			5.600	1/4-32 UNEF	M6	66	28	20	36	1.1	6	.0560	●	★
0.2264			5.750		1/4-20 UNC	66	28	20	36	1.2	6	.0575	●	★
0.2283			5.800		M6x0.5	66	28	20	36	1.2	6	.0580	●	★
0.2323			5.900			66	28	20	36	1.2	6	.0590	●	★
0.2344	15/64		5.954		1/4-28 UNF	66	28	20	36	1.2	6	.0595	●	★
0.2362			6.000	M7 / Rd8x1/10		66	28	20	36	1.2	6	.0600	●	★
0.2402			6.100	MJ7x1		79	34	24	36	1.2	8	.0610	●	★
0.2441			6.200	M7x0.75		79	34	24	36	1.2	8	.0620	●	★
0.2480			6.300	M7x0.5 / STI-M6		79	34	24	36	1.3	8	.0630	●	★
0.2500	1/4	E	6.350	1/16-27 NPSF		79	34	24	36	1.3	8	.0635	●	★
0.2520			6.400			79	34	24	36	1.3	8	.0640	●	★
0.2559			6.500	BSW 5/16-18		79	34	24	36	1.3	8	.0650	●	★
0.2570		F	6.528			79	34	24	36	1.3	8	.0653	●	★
0.2598			6.600	5/16-18 UNC	M7	79	34	24	36	1.3	8	.0660	●	★
0.2638			6.700	5/16-18 UNJC	M7x0.75	79	34	24	36	1.3	8	.0670	●	★
0.2656	17/64		6.746			79	34	24	36	1.3	8	.0675	●	★
0.2677			6.800	M8 / G 1/16		79	34	24	36	1.4	8	.0680	●	★
0.2717			6.900	5/16-24 UNF		79	34	24	36	1.4	8	.0690	●	★
0.2756			7.000	5/16-24 UNJF		79	34	24	36	1.4	8	.0700	●	★
0.2795			7.100	MJ8x1		79	41	29	36	1.4	8	.0710	●	★
0.2813	9/32	K	7.145			79	41	29	36	1.4	8	.0715	●	★
0.2835			7.200	5/16-32 UNEF		79	41	29	36	1.4	8	.0720	●	★
0.2854			7.250		5/16-18 UNC	79	41	29	36	1.4	8	.0725	●	★
0.2874			7.300			79	41	29	36	1.5	8	.0730	●	★
0.2913			7.400			79	41	29	36	1.5	8	.0740	●	★
0.2933			7.450		5/16-24 UNF / M8	79	41	29	36	1.5	8	.0745	●	★
0.2953			7.500	M8x0.5		79	41	29	36	1.5	8	.0750	●	★
0.2969	19/64		7.541			79	41	29	36	1.5	8	.0754	●	★
0.2992			7.600	Tr9x1.5	M8x1 / STI-M8	79	41	29	36	1.5	8	.0760	●	★
0.3031			7.700		M8x0.75	79	41	29	36	1.5	8	.0770	●	★
0.3071			7.800	M9		79	41	29	36	1.5	8	.0780	●	★
0.3110			7.900	BSW 3/8-16		79	41	29	36	1.6	8	.0790	●	★
0.3125	5/16		7.938			79	41	29	36	1.6	8	.0794	●	★
0.3150			8.000	3/8-16 UNC		79	41	29	36	1.6	8	.0800	●	★
0.3189			8.100	3/8-16 UNJC		89	47	35	40	1.6	10	.0810	●	★
0.3228			8.200	M9x0.75		89	47	35	40	1.6	10	.0820	●	★
0.3268			8.300	LK-UNC 3/8-16		89	47	35	40	1.6	10	.0830	●	★
0.3281	21/64		8.334			89	47	35	40	1.6	10	.0833	●	★
0.3307			8.400	STI-UNC 5/16-18		89	47	35	40	1.7	10	.0840	●	★
0.3346			8.500	3/8-24 UNF / M10		89	47	35	40	1.7	10	.0850	●	★
0.3386			8.600	3/8-24 UNJF	M9x1	89	47	35	40	1.7	10	.0860	●	★
0.3425			8.700	3/8-32 UNEF	M9x0.75	89	47	35	40	1.7	10	.0870	●	★

● = In stock
★ = Allow 7 days for delivery

- Product Finder
- v_c / f
- STEEL
- VA
- Accessories
- Tech. Info

Metric Shank

Carbide

TIALN
T14

DIN
6537 K

R30

2 Flutes

2FF

140°

IT9-IT10

DIN 6535

HA

 HE

Stub Length

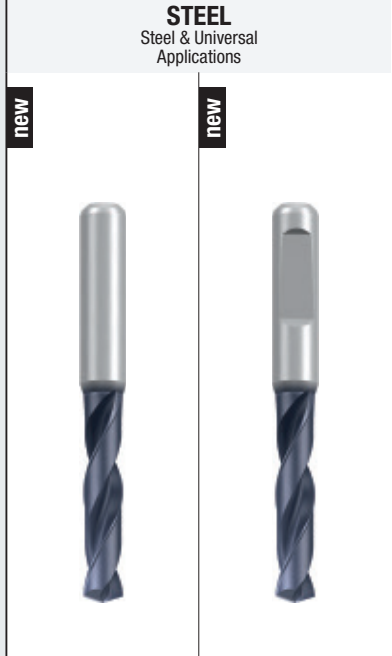
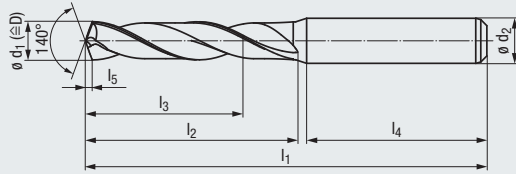

Applications – Material

P	1.1-5.1	K	1.1-4.2	N	1.1-5
N	2.1-8	N	5.1	H	1.1-2

Drill Depth

3 x D

Tool Identification

										TA103324		TA403324		
Nominal Size ϕd_1 m7				Taps	Roll Form Taps	mm					Dimens. ID	EF-Drill-STEEL DIN6537K-HA AK-2FF TIALN-T14	EF-Drill-STEEL DIN6537K-HE AK-2FF TIALN-T14	
inch	Fraction	Wire letter	mm			l_1	l_2	l_3	l_4	l_5	ϕd_2 h6			
0.3438	11/32		8.733	1/8-27 NPSC		89	47	35	40	1.7	10	.0873	●	★
0.3465			8.800	M10x1.25	3/8-16 UNC	89	47	35	40	1.7	10	.0880	●	★
0.3504			8.900	MJ10x1.25		89	47	35	40	1.8	10	.0890	●	★
0.3543			9.000	M10x1		89	47	35	40	1.8	10	.0900	●	★
0.3563			9.050		3/8-24 UNF	89	47	35	40	1.8	10	.0905	●	★
0.3583			9.100	1/8-27 NPSM		89	47	35	40	1.8	10	.0910	●	★
0.3594	23/64		9.129			89	47	35	40	1.8	10	.0913	●	★
0.3622			9.200	M10x0.75		89	47	35	40	1.8	10	.0920	●	★
0.3642			9.250		G 1/2-28	89	47	35	40	1.8	10	.0925	●	★
0.3661			9.300			89	47	35	40	1.8	10	.0930	●	★
0.3681			9.350		M10	89	47	35	40	1.8	10	.0935	●	★
0.3701			9.400	7/16-14 UNC		89	47	35	40	1.9	10	.0940	●	★
0.3740			9.500	7/16-14 UNJC	STI-M10	89	47	35	40	1.9	10	.0950	●	★
0.3750	3/8		9.525			89	47	35	40	1.9	10	.0953	●	★
0.3780			9.600		M10x1	89	47	35	40	1.9	10	.0960	●	★
0.3819			9.700	LK-UNC 7/16-14	M10x0.75	89	47	35	40	1.9	10	.0970	●	★
0.3858			9.800	STI-UNF 3/8-24		89	47	35	40	1.9	10	.0980	●	★
0.3898			9.900	7/16-20 UNF		89	47	35	40	2.0	10	.0990	●	★
0.3906	25/64		9.921			89	47	35	40	2.0	10	.0992	●	★
0.3937			10.000	7/16-20 UNJF		89	47	35	40	2.0	10	.1000	●	★
0.3976			10.100			102	55	40	45	2.0	12	.1010	●	★
0.4016			10.200	7/16-28 UNEF		102	55	40	45	2.0	12	.1020	●	★
0.4035			10.250		7/16-14 UNC	102	55	40	45	2.0	12	.1025	●	★
0.4055			10.300			102	55	40	45	2.0	12	.1030	●	★
0.4063	13/32		10.320			102	55	40	45	2.0	12	.1032	●	★
0.4134			10.500	M12x1.5		102	55	40	45	2.1	12	.1050	●	★
0.4154			10.550		7/16-20 UNF	102	55	40	45	2.1	12	.1055	●	★
0.4213			10.700	LK-M12		102	55	40	45	2.1	12	.1070	●	★
0.4219	27/64		10.716	1/2-13 UNC		102	55	40	45	2.1	12	.1072	●	★
0.4252			10.800	M12x1.25		102	55	40	45	2.1	12	.1080	●	★
0.4291			10.900	1/2-13 UNJC		102	55	40	45	2.1	12	.1090	●	★
0.4331			11.000	M12x1		102	55	40	45	2.2	12	.1100	●	★
0.4370			11.100	BSF 1/2-16		102	55	40	45	2.2	12	.1110	●	★
0.4375	7/16		11.113	LK-UNC 1/2-13		102	55	40	45	2.2	12	.1111	●	★
0.4409			11.200			102	55	40	45	2.2	12	.1120	●	★
0.4429			11.250	M12x0.75	M12	102	55	40	45	2.2	12	.1125	●	★
0.4469			11.350	Pg7	M12x1.5	102	55	40	45	2.2	12	.1135	●	★
0.4488			11.400	1/4-18 NPSC		102	55	40	45	2.2	12	.1140	●	★
0.4508			11.450		M12x1.25	102	55	40	45	2.2	12	.1145	●	★
0.4528			11.500	1/2-20 UNF		102	55	40	45	2.3	12	.1150	●	★
0.4531	29/64		11.509			102	55	40	45	2.3	12	.1151	●	★
0.4567			11.600	1/2-20 UNJF	M12x1	102	55	40	45	2.3	12	.1160	●	★
0.4606			11.700			102	55	40	45	2.3	12	.1170	●	★
0.4646			11.800	1/2-28 UNEF	1/2-13 UNC	102	55	40	45	2.3	12	.1180	●	★

Metric Shank

Carbide **TIALN T14**

DIN 6537 K **R30**

2 Flutes **2FF**

140° **IT9-IT10**

DIN 6535
HA HE

STEEL
Steel & Universal Applications

new

new



Stub Length

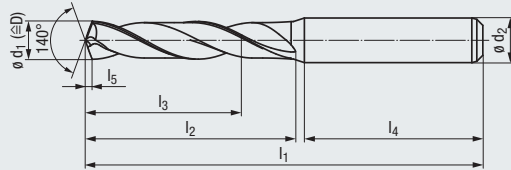

Applications – Material

P 1.1-5.1 K 1.1-4.2 N 1.1-5
N 2.1-8 N 5.1 H 1.1-2

Drill Depth

3 x D

Tool Identification

Tool Identification												TA103324	TA403324	
Nominal Size ø d ₁ m7				Taps	Roll Form Taps	mm						Dimens. ID	EF-Drill-STEEL DIN6537K-HA AK-2FF TIALN-T14	EF-Drill-STEEL DIN6537K-HE AK-2FF TIALN-T14
inch	Fraction	Wire letter	mm			l ₁	l ₂	l ₃	l ₄	l ₅	ø d ₂ h6			
0.4685			11.900			102	55	40	45	2.3	12	.1190	●	★
0.4688	15/32		11.908			102	55	40	45	2.3	12	.1191	●	★
0.4724			12.000	M14		102	55	40	45	2.4	12	.1200	●	★
0.4783			12.150		1/2-20 UNF	107	60	43	45	2.4	14	.1215	●	★
0.4803			12.200	Tr 14x2		107	60	43	45	2.4	14	.1220	●	★
0.4844	31/64		12.304	9/16-12 UNC		107	60	43	45	2.4	14	.1230	●	★
0.4921			12.500	M14x1.5		107	60	43	45	2.4	14	.1250	●	★
0.4941			12.550		G1/4-19	107	60	43	45	2.5	14	.1255	●	★
0.5000	1/2		12.700	LK-UNC 9/16-12		107	60	43	45	2.5	14	.1270	●	★
0.5039			12.800	M14x1.25		107	60	43	45	2.5	14	.1280	●	★
0.5118			13.000	9/16-18 UNJF		107	60	43	45	2.5	14	.1300	●	★
0.5157			13.100	STI-UNF 1/2-20	M14	107	60	43	45	2.6	14	.1310	●	★
0.5236			13.300	9/16-24 UNEF	9/16-12 UNC	107	60	43	45	2.6	14	.1330	●	★
0.5256			13.350		M14x1.5	107	60	43	45	2.6	14	.1335	●	★
0.5295			13.450		M14x1.25	107	60	43	45	2.6	14	.1345	●	★
0.5313	17/32		13.495	5/8-11 UNC		107	60	43	45	2.6	14	.1349	●	★
0.5315			13.500			107	60	43	45	2.6	14	.1350	●	★
0.5374			13.650	5/8-11 UNJC	9/16-18 UNF	107	60	43	45	2.7	14	.1365	●	★
0.5394			13.700			107	60	43	45	2.7	14	.1370	●	★
0.5469	35/64		13.891			107	60	43	45	2.7	14	.1389	●	★
0.5512			14.000	M16 / M15x1		107	60	43	45	2.7	14	.1400	●	★
0.5551			14.100			115	65	45	48	2.8	16	.1410	●	★
0.5625	9/16		14.288			115	65	45	48	2.8	16	.1429	●	★
0.5709			14.500	5/8-18 UNF		115	65	45	48	2.8	16	.1450	●	★
0.5748			14.600	5/8-18 UNJF	M15x1	115	65	45	48	2.9	16	.1460	●	★
0.5781	37/64		14.684	3/8-18 NPSC		115	65	45	48	2.9	16	.1468	●	★
0.5827			14.800		5/8-11 UNC	115	65	45	48	2.9	16	.1480	●	★
0.5906			15.000	M16x1		115	65	45	48	2.9	16	.1500	●	★
0.5938	19/32		15.083			115	65	45	48	2.9	16	.1508	●	★
0.5945			15.100		M16	115	65	45	48	2.9	16	.1510	●	★
0.6102			15.500	M18		115	65	45	48	3.0	16	.1550	●	★
0.6142			15.600		M16x1	115	65	45	48	3.0	16	.1560	●	★
0.6250	5/8		15.875			115	65	45	48	3.1	16	.1588	●	★
0.6299			16.000	M18x2		115	65	45	48	3.1	16	.1600	●	★
0.6406	41/64		16.272			123	73	51	48	3.2	18	.1627	●	★
0.6496			16.500	STI-UNC 5/8-11		123	73	51	48	3.2	18	.1650	●	★
0.6563	21/32		16.669	3/4-10 UNC		123	73	51	48	3.2	18	.1667	●	★
0.6693			17.000	M18x1		123	73	51	48	3.3	18	.1700	●	★
0.6875	11/16		17.463			123	73	51	48	3.4	18	.1746	●	★
0.6890			17.500	3/4-16 UNF / M20		123	73	51	48	3.4	18	.1750	●	★
0.7087			18.000	M20x2 / LK-M16		123	73	51	48	3.5	18	.1800	●	★
0.7480			19.000	M20x1		131	79	55	50	3.7	20	.1900	●	★
0.7500	3/4		19.050			131	79	55	50	3.7	20	.1905	●	★
0.7874			20.000	M22x2	G1/2-14	131	79	55	50	3.9	20	.2000	●	★

● = In stock
★ = Allow 7 days for delivery

Product Finder
V_c / f
STEEL
VA
Accessories
Tech. Info

3 x D
5 x D
6 x D
8 x D
2-3.5 x D



- Product Finder
- v_c / f
- STEEL
- VA
- Accessories
- Tech. Info

Metric Shank

Stub Length
Coolant Fed

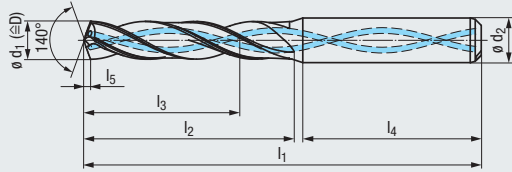

Carbide

TIALN
T14

DIN
6537 K

R30

2 Flutes

4FF

140°

IT9-IT10

DIN 6535

HA
HE

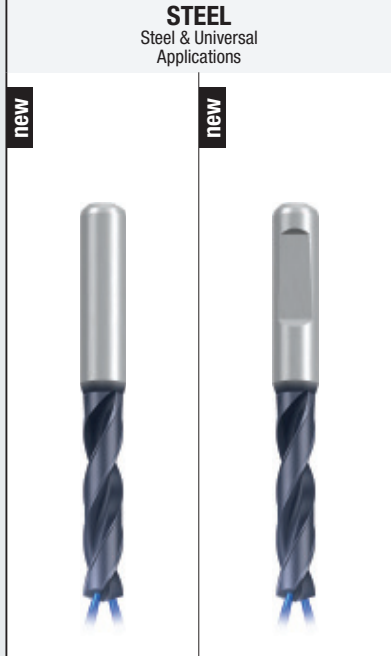

Applications – Material

P 1.1-5.1	M 1.1	K 1.1-4.2
N 1.1-5, 2.1-8	S 2.2-3	H 1.1-2

Drill Depth

3 x D

Tool Identification

											TA203344	TA503344		
Nominal Size ϕd_1 m7				Taps	Roll Form Taps	mm						Dimens. ID	EF-Drill-STEEL DIN6537K-HA IK-4FF TIALN-T14	EF-Drill-STEEL DIN6537K-HE IK-4FF TIALN-T14
inch	Fraction	Wire letter	mm			l_1	l_2	l_3	l_4	l_5	ϕd_2 h6			
0.1102			2.800	#6-32UNC	M3	57	16	11	36	0.6	6	.0280	●	★
0.1142			2.900	#6-32UNJC	#5-40UNC	57	16	11	36	0.6	6	.0290	●	★
0.1150			2.920		#5-44 UNF	57	16	11	36	0.6	6	.0292	●	★
0.1181			3.000	#6-40 UNF		62	20	14	36	0.6	6	.0300	●	★
0.1220			3.100	STI-#4-40		62	20	14	36	0.6	6	.0310	●	★
0.1240			3.150	M3.5x0.35	#6-32UNC	62	20	14	36	0.7	6	.0315	●	★
0.1250	1/8		3.175			62	20	14	36	0.7	6	.0318	●	★
0.1260			3.200	BSW ⁵ /32-32	#6-40 UNF	62	20	14	36	0.7	6	.0320	●	★
0.1280			3.250		M3.5	62	20	14	36	0.7	6	.0325	●	★
0.1299			3.300	M4		62	20	14	36	0.7	6	.0330	●	★
0.1331			3.380		M3.5x0.35	62	20	14	36	0.7	6	.0338	●	★
0.1339			3.400	MJ4x0.7		62	20	14	36	0.7	6	.0340	●	★
0.1378			3.500	#8-32UNC		62	20	14	36	0.7	6	.0350	●	★
0.1406	9/64	#28	3.571			62	20	14	36	0.7	6	.0357	●	★
0.1417			3.600	#8-36 UNJF		62	20	14	36	0.7	6	.0360	●	★
0.1457			3.700	M4.5	M4	62	20	14	36	0.8	6	.0370	●	★
0.1496		#25	3.800	STI-#6-32	#8-32UNC	66	24	17	36	0.8	6	.0380	●	★
0.1516			3.850		#8-36 UNF	66	24	17	36	0.8	6	.0385	●	★
0.1535			3.900	#10-24 UNC		66	24	17	36	0.8	6	.0390	●	★
0.1563	5/32		3.970			66	24	17	36	0.8	6	.0397	●	★
0.1575			4.000	M4.5x0.5		66	24	17	36	0.8	6	.0400	●	★
0.1590		#21	4.038			66	24	17	36	0.8	6	.0404	●	★
0.1614			4.100	#10-32 UNF		66	24	17	36	0.8	6	.0410	●	★
0.1654			4.200	M5 / STI-M4	M4.5	66	24	17	36	0.9	6	.0420	●	★
0.1693		#18	4.300	MJ5x0.8		66	24	17	36	0.9	6	.0430	●	★
0.1713			4.350		#10-24 UNC	66	24	17	36	0.9	6	.0435	●	★
0.1719	11/64		4.366			66	24	17	36	0.9	6	.0437	●	★
0.1732			4.400	M5x0.75		66	24	17	36	0.9	6	.0440	●	★
0.1752			4.450		#10-32 UNF	66	24	17	36	0.9	6	.0445	●	★
0.1772			4.500	#12-24 UNC		66	24	17	36	0.9	6	.0450	●	★
0.1811			4.600	#12-28 UNF		66	24	17	36	0.9	6	.0460	●	★
0.1831			4.650	#12-24 UNJC	M5	66	24	17	36	0.9	6	.0465	●	★
0.1850		#13	4.700	LK-UNC#12-24		66	24	17	36	1.0	6	.0470	●	★
0.1875	3/16		4.763	#12-28 UNJF		66	28	20	36	1.0	6	.0476	●	★
0.1890		#12	4.800	#12-32 UNEF	M5x0.5 / STI-M5	66	28	20	36	1.0	6	.0480	●	★
0.1929			4.900			66	28	20	36	1.0	6	.0490	●	★
0.1969			5.000	M6	#12-24 UNC	66	28	20	36	1.0	6	.0500	●	★
0.2008			5.100	MJ6x1	#12-28 UNF	66	28	20	36	1.0	6	.0510	●	★
0.2010		#7	5.106			66	28	20	36	1.0	6	.0511	●	★
0.2031	13/64		5.159			66	28	20	36	1.0	6	.0516	●	★
0.2047			5.200	1/4-20 UNC		66	28	20	36	1.0	6	.0520	●	★
0.2087			5.300	1/4-20 UNJC		66	28	20	36	1.1	6	.0530	●	★
0.2126			5.400			66	28	20	36	1.1	6	.0540	●	★
0.2130		#3	5.410			66	28	20	36	1.1	6	.0541	●	★

Metric Shank

Stub Length
Coolant Fed

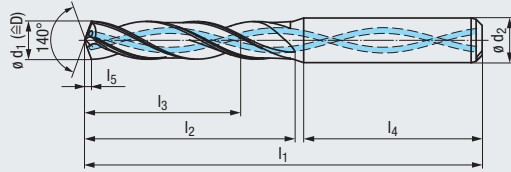

Carbide **TIALN T14**

DIN 6537 K **R30**

2 Flutes **4FF**

140° **IT9-IT10**

DIN 6535
HA HE

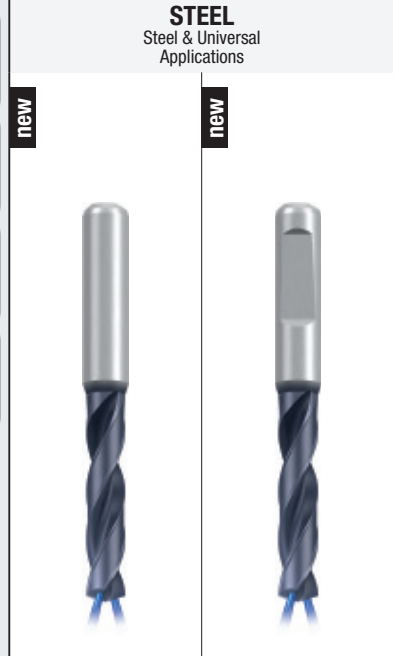

- Product Finder
- V_c / f
- STEEL
- VA
- Accessories
- Tech. Info

Applications – Material

P 1.1-5.1 M 1.1 K 1.1-4.2
N 1.1-5, 2.1-8 S 2.2-3 H 1.1-2

Drill Depth

3 x D

Tool Identification

Tool Identification													TA203344	TA503344	
Nominal Size ø d ₁ m7				Taps	Roll Form Taps	mm							Dimens. ID	EF-Drill-STEEL DIN6537K-HA IK-4FF TIALN-T14	EF-Drill-STEEL DIN6537K-HE IK-4FF TIALN-T14
inch	Fraction	Wire letter	mm			l ₁	l ₂	l ₃	l ₄	l ₅	ø d ₂ h6				
0.2165			5.500	1/4-28 UNF		66	28	20	36	1.1	6	.0550	●	★	
0.2187	7/32		5.556	1/4-28 UNJF		66	28	20	36	1.1	6	.0556	●	★	
0.2205			5.600	1/4-32 UNEF	M6	66	28	20	36	1.1	6	.0560	●	★	
0.2264			5.750		1/4-20 UNC	66	28	20	36	1.2	6	.0575	●	★	
0.2283			5.800		M6x0.5	66	28	20	36	1.2	6	.0580	●	★	
0.2323			5.900			66	28	20	36	1.2	6	.0590	●	★	
0.2344	15/64		5.954		1/4-28 UNF	66	28	20	36	1.2	6	.0595	●	★	
0.2362			6.000	M7 / Rd8x1/10		66	28	20	36	1.2	6	.0600	●	★	
0.2402			6.100	MJ7x1		79	34	24	36	1.2	8	.0610	●	★	
0.2441			6.200	M7x0.75		79	34	24	36	1.2	8	.0620	●	★	
0.2480			6.300	M7x0.5 / STI-M6		79	34	24	36	1.3	8	.0630	●	★	
0.2500	1/4	E	6.350	1/16-27 NPSF		79	34	24	36	1.3	8	.0635	●	★	
0.2520			6.400			79	34	24	36	1.3	8	.0640	●	★	
0.2559			6.500	BSW 5/16-18		79	34	24	36	1.3	8	.0650	●	★	
0.2570		F	6.528			79	34	24	36	1.3	8	.0653	●	★	
0.2598			6.600	5/16-18 UNC	M7	79	34	24	36	1.3	8	.0660	●	★	
0.2638			6.700	5/16-18 UNJC	M7x0.75	79	34	24	36	1.3	8	.0670	●	★	
0.2656	17/64		6.746			79	34	24	36	1.3	8	.0675	●	★	
0.2677			6.800	M8 / G 1/16		79	34	24	36	1.4	8	.0680	●	★	
0.2717			6.900	5/16-24 UNF		79	34	24	36	1.4	8	.0690	●	★	
0.2756			7.000	5/16-24 UNJF		79	34	24	36	1.4	8	.0700	●	★	
0.2795			7.100	MJ8x1		79	41	29	36	1.4	8	.0710	●	★	
0.2813	9/32	K	7.145			79	41	29	36	1.4	8	.0715	●	★	
0.2835			7.200	5/16-32 UNEF		79	41	29	36	1.4	8	.0720	●	★	
0.2854			7.250		5/16-18 UNC	79	41	29	36	1.4	8	.0725	●	★	
0.2874			7.300			79	41	29	36	1.5	8	.0730	●	★	
0.2913			7.400			79	41	29	36	1.5	8	.0740	●	★	
0.2933			7.450		5/16-24 UNF / M8	79	41	29	36	1.5	8	.0745	●	★	
0.2953			7.500	M8x0.5		79	41	29	36	1.5	8	.0750	●	★	
0.2969	19/64		7.541			79	41	29	36	1.5	8	.0754	●	★	
0.2992			7.600	Tr9x1.5	M8x1 / STI-M8	79	41	29	36	1.5	8	.0760	●	★	
0.3031			7.700		M8x0.75	79	41	29	36	1.5	8	.0770	●	★	
0.3071			7.800	M9		79	41	29	36	1.5	8	.0780	●	★	
0.3110			7.900	BSW 3/8-16		79	41	29	36	1.6	8	.0790	●	★	
0.3125	5/16		7.938			79	41	29	36	1.6	8	.0794	●	★	
0.3150			8.000	3/8-16 UNC		79	41	29	36	1.6	8	.0800	●	★	
0.3189			8.100	3/8-16 UNJC		89	47	35	40	1.6	10	.0810	●	★	
0.3228			8.200	M9x0.75		89	47	35	40	1.6	10	.0820	●	★	
0.3268			8.300	LK-UNC 3/8-16		89	47	35	40	1.6	10	.0830	●	★	
0.3281	21/64		8.334			89	47	35	40	1.6	10	.0833	●	★	
0.3307			8.400	STI-UNC 5/16-18		89	47	35	40	1.7	10	.0840	●	★	
0.3346			8.500	3/8-24 UNF / M10		89	47	35	40	1.7	10	.0850	●	★	
0.3386			8.600	3/8-24 UNJF	M9x1	89	47	35	40	1.7	10	.0860	●	★	
0.3425			8.700	3/8-32 UNEF	M9x0.75	89	47	35	40	1.7	10	.0870	●	★	

● = In stock
★ = Allow 7 days for delivery

- Product Finder
- v_c / f
- STEEL
- VA
- Accessories
- Tech. Info

Metric Shank

Stub Length
Coolant Fed

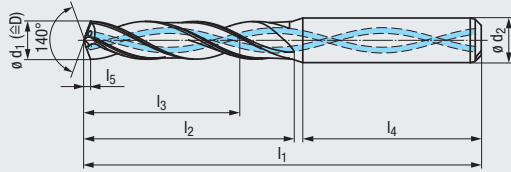

Carbide

TIALN
T14

DIN
6537 K

R30

2 Flutes

4FF

140°

IT9-IT10

DIN 6535

HA
HE

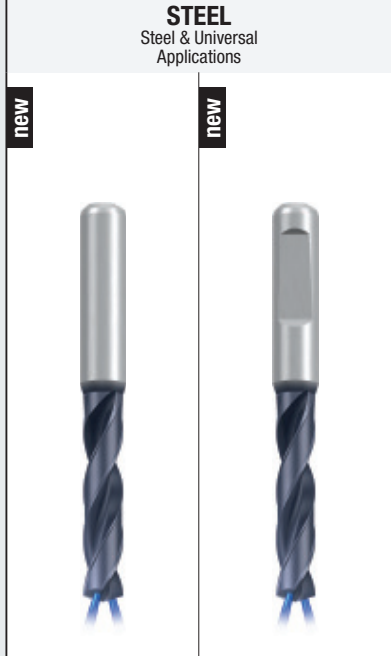

Applications – Material

P 1.1-5.1	M 1.1	K 1.1-4.2
N 1.1-5, 2.1-8	S 2.2-3	H 1.1-2

Drill Depth

3 x D

Tool Identification

										TA203344		TA503344		
Nominal Size ϕd_1 m7				Taps	Roll Form Taps	mm					Dimens. ID	EF-Drill-STEEL DIN6537K-HA IK-4FF TIALN-T14	EF-Drill-STEEL DIN6537K-HE IK-4FF TIALN-T14	
inch	Fraction	Wire letter	mm			l_1	l_2	l_3	l_4	l_5	ϕd_2 h6			
0.3438	11/32		8.733	1/8-27NPSC		89	47	35	40	1.7	10	.0873	●	★
0.3465			8.800	M10x1.25	3/8-16UNC	89	47	35	40	1.7	10	.0880	●	★
0.3504			8.900	MJ10x1.25		89	47	35	40	1.8	10	.0890	●	★
0.3543			9.000	M10x1		89	47	35	40	1.8	10	.0900	●	★
0.3563			9.050		3/8-24UNF	89	47	35	40	1.8	10	.0905	●	★
0.3583			9.100	1/8-27NPSM		89	47	35	40	1.8	10	.0910	●	★
0.3594	23/64		9.129			89	47	35	40	1.8	10	.0913	●	★
0.3622			9.200	M10x0.75		89	47	35	40	1.8	10	.0920	●	★
0.3642			9.250		G 1/2-28	89	47	35	40	1.8	10	.0925	●	★
0.3661			9.300			89	47	35	40	1.8	10	.0930	●	★
0.3681			9.350		M10	89	47	35	40	1.8	10	.0935	●	★
0.3701			9.400	7/16-14UNC		89	47	35	40	1.9	10	.0940	●	★
0.3740			9.500	7/16-14UNJC	STI-M10	89	47	35	40	1.9	10	.0950	●	★
0.3750	3/8		9.525			89	47	35	40	1.9	10	.0953	●	★
0.3780			9.600		M10x1	89	47	35	40	1.9	10	.0960	●	★
0.3819			9.700	LK-UNC 7/16-14	M10x0.75	89	47	35	40	1.9	10	.0970	●	★
0.3858			9.800	STI-UNF 3/8-24		89	47	35	40	1.9	10	.0980	●	★
0.3898			9.900	7/16-20UNF		89	47	35	40	2.0	10	.0990	●	★
0.3906	25/64		9.921			89	47	35	40	2.0	10	.0992	●	★
0.3937			10.000	7/16-20UNJF		89	47	35	40	2.0	10	.1000	●	★
0.3976			10.100			102	55	40	45	2.0	12	.1010	●	★
0.4016			10.200	7/16-28UNEF		102	55	40	45	2.0	12	.1020	●	★
0.4035			10.250		7/16-14UNC	102	55	40	45	2.0	12	.1025	●	★
0.4055			10.300			102	55	40	45	2.0	12	.1030	●	★
0.4063	13/32		10.320			102	55	40	45	2.0	12	.1032	●	★
0.4134			10.500	M12x1.5		102	55	40	45	2.1	12	.1050	●	★
0.4154			10.550		7/16-20UNF	102	55	40	45	2.1	12	.1055	●	★
0.4213			10.700	LK-M12		102	55	40	45	2.1	12	.1070	●	★
0.4219	27/64		10.716	1/2-13UNC		102	55	40	45	2.1	12	.1072	●	★
0.4252			10.800	M12x1.25		102	55	40	45	2.1	12	.1080	●	★
0.4291			10.900	1/2-13UNJC		102	55	40	45	2.1	12	.1090	●	★
0.4331			11.000	M12x1		102	55	40	45	2.2	12	.1100	●	★
0.4370			11.100	BSF 1/2-16		102	55	40	45	2.2	12	.1110	●	★
0.4375	7/16		11.113	LK-UNC 1/2-13		102	55	40	45	2.2	12	.1111	●	★
0.4409			11.200			102	55	40	45	2.2	12	.1120	●	★
0.4429			11.250	M12x0.75	M12	102	55	40	45	2.2	12	.1125	●	★
0.4469			11.350	Pg7	M12x1.5	102	55	40	45	2.2	12	.1135	●	★
0.4488			11.400	1/4-18NPSC		102	55	40	45	2.2	12	.1140	●	★
0.4508			11.450		M12x1.25	102	55	40	45	2.2	12	.1145	●	★
0.4528			11.500	1/2-20UNF		102	55	40	45	2.3	12	.1150	●	★
0.4531	29/64		11.509			102	55	40	45	2.3	12	.1151	●	★
0.4567			11.600	1/2-20UNJF	M12x1	102	55	40	45	2.3	12	.1160	●	★
0.4606			11.700			102	55	40	45	2.3	12	.1170	●	★
0.4646			11.800	1/2-28UNEF	1/2-13UNC	102	55	40	45	2.3	12	.1180	●	★

Metric Shank

Stub Length
Coolant Fed

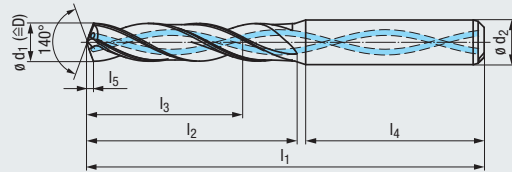

Carbide

TIALN
T14

DIN
6537 K

R30

2 Flutes



4FF



140°



IT9-IT10



DIN 6535



STEEL
Steel & Universal
Applications

new



new



Applications – Material

P	1.1-5.1	M	1.1	K	1.1-4.2
N	1.1-5.2, 1-8	S	2.2-3	H	1.1-2

Drill Depth

3 x D

Tool Identification

Tool Identification													TA203344	TA503344	
Nominal Size ø d ₁ m7				Taps	Roll Form Taps	mm							Dimens. ID	EF-Drill-STEEL DIN6537K-HA IK-4FF TIALN-T14	EF-Drill-STEEL DIN6537K-HE IK-4FF TIALN-T14
inch	Fraction	Wire letter	mm			l ₁	l ₂	l ₃	l ₄	l ₅	ø d ₂ h6				
0.4685			11.900			102	55	40	45	2.3	12	.1190	●	★	
0.4688	15/32		11.908			102	55	40	45	2.3	12	.1191	●	★	
0.4724			12.000	M14		102	55	40	45	2.4	12	.1200	●	★	
0.4783			12.150		1/2-20 UNF	107	60	43	45	2.4	14	.1215	●	★	
0.4803			12.200	Tr 14x2		107	60	43	45	2.4	14	.1220	●	★	
0.4844	31/64		12.304	9/16-12 UNC		107	60	43	45	2.4	14	.1230	●	★	
0.4921			12.500	M14x1.5		107	60	43	45	2.4	14	.1250	●	★	
0.4941			12.550		G1/4-19	107	60	43	45	2.5	14	.1255	●	★	
0.5000	1/2		12.700	LK-UNC 9/16-12		107	60	43	45	2.5	14	.1270	●	★	
0.5039			12.800	M14x1.25		107	60	43	45	2.5	14	.1280	●	★	
0.5118			13.000	9/16-18 UNJF		107	60	43	45	2.5	14	.1300	●	★	
0.5157			13.100	STI-UNF 1/2-20	M14	107	60	43	45	2.6	14	.1310	●	★	
0.5236			13.300	9/16-24 UNEF	9/16-12 UNC	107	60	43	45	2.6	14	.1330	●	★	
0.5256			13.350		M14x1.5	107	60	43	45	2.6	14	.1335	●	★	
0.5295			13.450		M14x1.25	107	60	43	45	2.6	14	.1345	●	★	
0.5313	17/32		13.495	5/8-11 UNC		107	60	43	45	2.6	14	.1349	●	★	
0.5315			13.500			107	60	43	45	2.6	14	.1350	●	★	
0.5374			13.650	5/8-11 UNJC	9/16-18 UNF	107	60	43	45	2.7	14	.1365	●	★	
0.5394			13.700			107	60	43	45	2.7	14	.1370	●	★	
0.5469	35/64		13.891			107	60	43	45	2.7	14	.1389	●	★	
0.5512			14.000	M16 / M15x1		107	60	43	45	2.7	14	.1400	●	★	
0.5551			14.100			115	65	45	48	2.8	16	.1410	●	★	
0.5625	9/16		14.288			115	65	45	48	2.8	16	.1429	●	★	
0.5709			14.500	5/8-18 UNF		115	65	45	48	2.8	16	.1450	●	★	
0.5748			14.600	5/8-18 UNJF	M15x1	115	65	45	48	2.9	16	.1460	●	★	
0.5781	37/64		14.684	3/8-18 NPSC		115	65	45	48	2.9	16	.1468	●	★	
0.5827			14.800		5/8-11 UNC	115	65	45	48	2.9	16	.1480	●	★	
0.5906			15.000	M16x1		115	65	45	48	2.9	16	.1500	●	★	
0.5938	19/32		15.083			115	65	45	48	2.9	16	.1508	●	★	
0.5945			15.100		M16	115	65	45	48	2.9	16	.1510	●	★	
0.6102			15.500	M18		115	65	45	48	3.0	16	.1550	●	★	
0.6142			15.600		M16x1	115	65	45	48	3.0	16	.1560	●	★	
0.6250	5/8		15.875			115	65	45	48	3.1	16	.1588	●	★	
0.6299			16.000	M18x2		115	65	45	48	3.1	16	.1600	●	★	
0.6406	41/64		16.272			123	73	51	48	3.2	18	.1627	●	★	
0.6496			16.500	STI-UNC 5/8-11		123	73	51	48	3.2	18	.1650	●	★	
0.6563	21/32		16.669	3/4-10 UNC		123	73	51	48	3.2	18	.1667	●	★	
0.6693			17.000	M18x1		123	73	51	48	3.3	18	.1700	●	★	
0.6875	11/16		17.463			123	73	51	48	3.4	18	.1746	●	★	
0.6890			17.500	3/4-16 UNF / M20		123	73	51	48	3.4	18	.1750	●	★	
0.7087			18.000	M20x2 / LK-M16		123	73	51	48	3.5	18	.1800	●	★	
0.7480			19.000	M20x1		131	79	55	50	3.7	20	.1900	●	★	
0.7500	3/4		19.050			131	79	55	50	3.7	20	.1905	●	★	
0.7874			20.000	M22x2	G1/2-14	131	79	55	50	3.9	20	.2000	●	★	

● = In stock
★ = Allow 7 days for delivery

3 x D
5 x D
6 x D
8 x D
2-3.5 x D



Product Finder
V_c / f
STEEL
VA
Accessories
Tech. Info

- Product Finder
- v_c / f
- STEEL
- VA
- Accessories
- Tech. Info

Metric Shank

Standard Length Coolant Fed

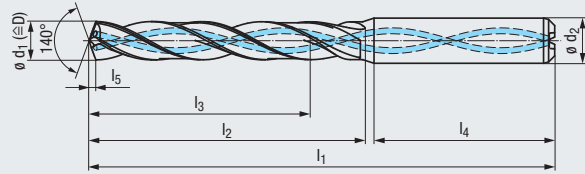

Carbide

TIALN
T14

DIN
6537 L

R30

2 Flutes

4FF

140°

IT9-IT10

DIN 6535

HA
HE

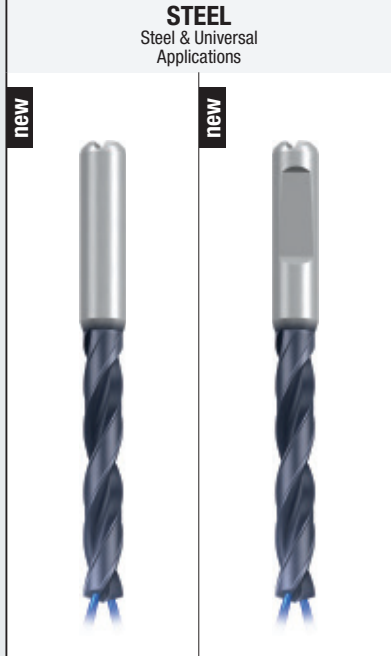

Applications – Material

P 1.1-5.1

M 1.1

K 1.1-4.2

N 1.1-5, 2.1-8

S 2.2-3

H 1.1-2

Drill Depth

5 x D

Tool Identification

											TA213344		TA513344	
Nominal Size ϕd_1 m7				Taps	Roll Form Taps	mm						Dimens. ID	EF-Drill-STEEL DIN6537L-HA IK-4FF TIALN-T14	EF-Drill-STEEL DIN6537L-HE IK-4FF TIALN-T14
inch	Fraction	Wire letter	mm			l_1	l_2	l_3	l_4	l_5	ϕd_2 h6			
0.1102			2.800	#6-32UNC	M3	61	22	17	36	0.6	6	.0280	●	★
0.1142			2.900	#6-32UNJC	#5-40UNC	61	22	17	36	0.6	6	.0290	●	★
0.1150			2.920		#5-44UNF	61	22	17	36	0.6	6	.0292	●	★
0.1181			3.000	#6-40UNF		66	28	23	36	0.6	6	.0300	●	★
0.1220			3.100	STI-#4-40		66	28	23	36	0.6	6	.0310	●	★
0.1240			3.150	M3.5x0.35	#6-32UNC	66	28	23	36	0.7	6	.0315	●	★
0.1250	1/8		3.175			66	28	23	36	0.7	6	.0318	●	★
0.1260			3.200	BSW ⁵ /32-32	#6-40UNF	66	28	23	36	0.7	6	.0320	●	★
0.1280			3.250		M3.5	66	28	23	36	0.7	6	.0325	●	★
0.1299			3.300	M4		66	28	23	36	0.7	6	.0330	●	★
0.1331			3.380		M3.5x0.35	66	28	23	36	0.7	6	.0338	●	★
0.1339			3.400	MJ4x0.7		66	28	23	36	0.7	6	.0340	●	★
0.1378			3.500	#8-32UNC		66	28	23	36	0.7	6	.0350	●	★
0.1406	9/64	#28	3.571			66	28	23	36	0.7	6	.0357	●	★
0.1417			3.600	#8-36UNJF		66	28	23	36	0.7	6	.0360	●	★
0.1457			3.700	M4.5	M4	66	28	23	36	0.8	6	.0370	●	★
0.1496		#25	3.800	STI-#6-32	#8-32UNC	74	36	29	36	0.8	6	.0380	●	★
0.1516			3.850		#8-36UNF	74	36	29	36	0.8	6	.0385	●	★
0.1535			3.900	#10-24UNC		74	36	29	36	0.8	6	.0390	●	★
0.1563	5/32		3.970			74	36	29	36	0.8	6	.0397	●	★
0.1575			4.000	M4.5x0.5		74	36	29	36	0.8	6	.0400	●	★
0.1590		#21	4.038			74	36	29	36	0.8	6	.0404	●	★
0.1614			4.100	#10-32UNF		74	36	29	36	0.8	6	.0410	●	★
0.1654			4.200	M5 / STI-M4	M4.5	74	36	29	36	0.9	6	.0420	●	★
0.1693		#18	4.300	MJ5x0.8		74	36	29	36	0.9	6	.0430	●	★
0.1713			4.350		#10-24UNC	74	36	29	36	0.9	6	.0435	●	★
0.1719	11/64		4.366			74	36	29	36	0.9	6	.0437	●	★
0.1732			4.400	M5x0.75		74	36	29	36	0.9	6	.0440	●	★
0.1752			4.450		#10-32UNF	74	36	29	36	0.9	6	.0445	●	★
0.1772			4.500	#12-24UNC		74	36	29	36	0.9	6	.0450	●	★
0.1811			4.600	#12-28UNF		74	36	29	36	0.9	6	.0460	●	★
0.1831			4.650	#12-24UNJC	M5	74	36	29	36	0.9	6	.0465	●	★
0.1850		#13	4.700	LK-UNC#12-24		74	36	29	36	1.0	6	.0470	●	★
0.1875	3/16		4.763	#12-28UNJF		82	44	35	36	1.0	6	.0476	●	★
0.1890		#12	4.800	#12-32UNEF	M5x0.5 / STI-M5	82	44	35	36	1.0	6	.0480	●	★
0.1929			4.900			82	44	35	36	1.0	6	.0490	●	★
0.1969			5.000	M6	#12-24UNC	82	44	35	36	1.0	6	.0500	●	★
0.2008			5.100	MJ6x1	#12-28UNF	82	44	35	36	1.0	6	.0510	●	★
0.2010		#7	5.106			82	44	35	36	1.0	6	.0511	●	★
0.2031	13/64		5.159			82	44	35	36	1.0	6	.0516	●	★
0.2047			5.200	1/4-20UNC		82	44	35	36	1.0	6	.0520	●	★
0.2087			5.300	1/4-20UNJC		82	44	35	36	1.1	6	.0530	●	★
0.2126			5.400			82	44	35	36	1.1	6	.0540	●	★
0.2130		#3	5.410			82	44	35	36	1.1	6	.0541	●	★

Metric Shank

Carbide **TIALN T14**

DIN 6537 L **R30**

2 Flutes **4FF**

140° **IT9-IT10**

DIN 6535
HA HE

STEEL
Steel & Universal Applications



Standard Length
Coolant Fed

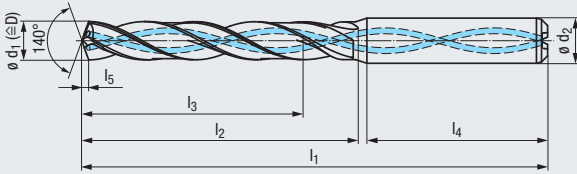

Applications – Material

P 1.1-5.1 M 1.1 K 1.1-4.2
N 1.1-5, 2.1-8 S 2.2-3 H 1.1-2

Drill Depth

5 x D

Tool Identification

Tool Identification													TA213344	TA513344	
Nominal Size ø d ₁ m7				Taps	Roll Form Taps	mm							Dimens. ID	EF-Drill-STEEL DIN6537L-HA IK-4FF TIALN-T14	EF-Drill-STEEL DIN6537L-HE IK-4FF TIALN-T14
inch	Fraction	Wire letter	mm			l ₁	l ₂	l ₃	l ₄	l ₅	ø d ₂ h6				
0.2165			5.500	1/4-28 UNF		82	44	35	36	1.1	6	.0550	●	★	
0.2187	7/32		5.556	1/4-28 UNJF		82	44	35	36	1.1	6	.0556	●	★	
0.2205			5.600	1/4-32 UNEF	M6	82	44	35	36	1.1	6	.0560	●	★	
0.2264			5.750		1/4-20 UNC	82	44	35	36	1.2	6	.0575	●	★	
0.2283			5.800		M6x0.5	82	44	35	36	1.2	6	.0580	●	★	
0.2323			5.900			82	44	35	36	1.2	6	.0590	●	★	
0.2344	15/64		5.954		1/4-28 UNF	82	44	35	36	1.2	6	.0595	●	★	
0.2362			6.000	M7 / Rd8x1/10		82	44	35	36	1.2	6	.0600	●	★	
0.2402			6.100	MJ7x1		91	53	43	36	1.2	8	.0610	●	★	
0.2441			6.200	M7x0.75		91	53	43	36	1.2	8	.0620	●	★	
0.2480			6.300	M7x0.5 / STI-M6		91	53	43	36	1.3	8	.0630	●	★	
0.2500	1/4	E	6.350	1/16-27 NPSF		91	53	43	36	1.3	8	.0635	●	★	
0.2520			6.400			91	53	43	36	1.3	8	.0640	●	★	
0.2559			6.500	BSW 5/16-18		91	53	43	36	1.3	8	.0650	●	★	
0.2570		F	6.528			91	53	43	36	1.3	8	.0653	●	★	
0.2598			6.600	5/16-18 UNC	M7	91	53	43	36	1.3	8	.0660	●	★	
0.2638			6.700	5/16-18 UNJC	M7x0.75	91	53	43	36	1.3	8	.0670	●	★	
0.2656	17/64		6.746			91	53	43	36	1.3	8	.0675	●	★	
0.2677			6.800	M8 / G 1/16		91	53	43	36	1.4	8	.0680	●	★	
0.2717			6.900	5/16-24 UNF		91	53	43	36	1.4	8	.0690	●	★	
0.2756			7.000	5/16-24 UNJF		91	53	43	36	1.4	8	.0700	●	★	
0.2795			7.100	MJ8x1		91	53	43	36	1.4	8	.0710	●	★	
0.2813	9/32	K	7.145			91	53	43	36	1.4	8	.0715	●	★	
0.2835			7.200	5/16-32 UNEF		91	53	43	36	1.4	8	.0720	●	★	
0.2854			7.250		5/16-18 UNC	91	53	43	36	1.4	8	.0725	●	★	
0.2874			7.300			91	53	43	36	1.5	8	.0730	●	★	
0.2913			7.400			91	53	43	36	1.5	8	.0740	●	★	
0.2933			7.450		5/16-24 UNF / M8	91	53	43	36	1.5	8	.0745	●	★	
0.2953			7.500	M8x0.5		91	53	43	36	1.5	8	.0750	●	★	
0.2969	19/64		7.541			91	53	43	36	1.5	8	.0754	●	★	
0.2992			7.600	Tr9x1.5	M8x1 / STI-M8	91	53	43	36	1.5	8	.0760	●	★	
0.3031			7.700		M8x0.75	91	53	43	36	1.5	8	.0770	●	★	
0.3071			7.800	M9		91	53	43	36	1.5	8	.0780	●	★	
0.3110			7.900	BSW 3/8-16		91	53	43	36	1.6	8	.0790	●	★	
0.3125	5/16		7.938			91	53	43	36	1.6	8	.0794	●	★	
0.3150			8.000	3/8-16 UNC		91	53	43	36	1.6	8	.0800	●	★	
0.3189			8.100	3/8-16 UNJC		103	61	49	40	1.6	10	.0810	●	★	
0.3228			8.200	M9x0.75		103	61	49	40	1.6	10	.0820	●	★	
0.3268			8.300	LK-UNC 3/8-16		103	61	49	40	1.6	10	.0830	●	★	
0.3281	21/64		8.334			103	61	49	40	1.6	10	.0833	●	★	
0.3307			8.400	STI-UNC 5/16-18		103	61	49	40	1.7	10	.0840	●	★	
0.3346			8.500	3/8-24 UNF / M10		103	61	49	40	1.7	10	.0850	●	★	
0.3386			8.600	3/8-24 UNJF	M9x1	103	61	49	40	1.7	10	.0860	●	★	
0.3425			8.700	3/8-32 UNEF	M9x0.75	103	61	49	40	1.7	10	.0870	●	★	

● = In stock
★ = Allow 7 days for delivery

- Product Finder
- v_c / f
- STEEL
- VA
- Accessories
- Tech. Info

Metric Shank

Carbide

TIALN
T14

DIN
6537 L

R30

2 Flutes

4FF

140°

IT9-IT10

DIN 6535

HA
 HE

Standard Length Coolant Fed

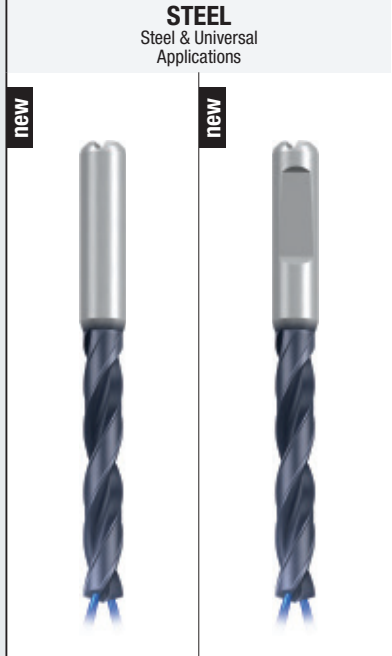
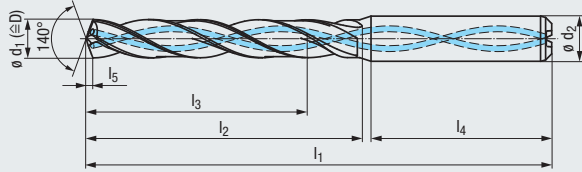

Applications – Material

P 1.1-5.1	M 1.1	K 1.1-4.2
N 1.1-5, 2.1-8	S 2.2-3	H 1.1-2

Drill Depth

5 x D

Tool Identification

											TA213344	TA513344		
Nominal Size ø d ₁ m7				Taps	Roll Form Taps	mm						Dimens. ID	EF-Drill-STEEL DIN6537L-HA IK-4FF TIALN-T14	EF-Drill-STEEL DIN6537L-HE IK-4FF TIALN-T14
inch	Fraction	Wire letter	mm			l ₁	l ₂	l ₃	l ₄	l ₅	ø d ₂ h6			
0.3438	11/32		8.733	1/8-27NPSC		103	61	49	40	1.7	10	.0873	●	★
0.3465			8.800	M10x1.25	3/8-16UNC	103	61	49	40	1.7	10	.0880	●	★
0.3504			8.900	MJ10x1.25		103	61	49	40	1.8	10	.0890	●	★
0.3543			9.000	M10x1		103	61	49	40	1.8	10	.0900	●	★
0.3563			9.050		3/8-24UNF	103	61	49	40	1.8	10	.0905	●	★
0.3583			9.100	1/8-27NPSM		103	61	49	40	1.8	10	.0910	●	★
0.3594	23/64		9.129			103	61	49	40	1.8	10	.0913	●	★
0.3622			9.200	M10x0.75		103	61	49	40	1.8	10	.0920	●	★
0.3642			9.250		G 1/2-28	103	61	49	40	1.8	10	.0925	●	★
0.3661			9.300			103	61	49	40	1.8	10	.0930	●	★
0.3681			9.350		M10	103	61	49	40	1.8	10	.0935	●	★
0.3701			9.400	7/16-14UNC		103	61	49	40	1.9	10	.0940	●	★
0.3740			9.500	7/16-14UNJC	STI-M10	103	61	49	40	1.9	10	.0950	●	★
0.3750	3/8		9.525			103	61	49	40	1.9	10	.0953	●	★
0.3780			9.600		M10x1	103	61	49	40	1.9	10	.0960	●	★
0.3819			9.700	LK-UNC 7/16-14	M10x0.75	103	61	49	40	1.9	10	.0970	●	★
0.3858			9.800	STI-UNF 3/8-24		103	61	49	40	1.9	10	.0980	●	★
0.3898			9.900	7/16-20UNF		103	61	49	40	2.0	10	.0990	●	★
0.3906	25/64		9.921			103	61	49	40	2.0	10	.0992	●	★
0.3937			10.000	7/16-20UNJF		103	61	49	40	2.0	10	.1000	●	★
0.3976			10.100			118	71	56	45	2.0	12	.1010	●	★
0.4016			10.200	7/16-28UNEF		118	71	56	45	2.0	12	.1020	●	★
0.4035			10.250		7/16-14UNC	118	71	56	45	2.0	12	.1025	●	★
0.4055			10.300			118	71	56	45	2.0	12	.1030	●	★
0.4063	13/32		10.320			118	71	56	45	2.0	12	.1032	●	★
0.4134			10.500	M12x1.5		118	71	56	45	2.1	12	.1050	●	★
0.4154			10.550		7/16-20UNF	118	71	56	45	2.1	12	.1055	●	★
0.4213			10.700	LK-M12		118	71	56	45	2.1	12	.1070	●	★
0.4219	27/64		10.716	1/2-13UNC		118	71	56	45	2.1	12	.1072	●	★
0.4252			10.800	M12x1.25		118	71	56	45	2.1	12	.1080	●	★
0.4291			10.900	1/2-13UNJC		118	71	56	45	2.1	12	.1090	●	★
0.4331			11.000	M12x1		118	71	56	45	2.2	12	.1100	●	★
0.4370			11.100	BSF 1/2-16		118	71	56	45	2.2	12	.1110	●	★
0.4375	7/16		11.113	LK-UNC 1/2-13		118	71	56	45	2.2	12	.1111	●	★
0.4409			11.200			118	71	56	45	2.2	12	.1120	●	★
0.4429			11.250	M12x0.75	M12	118	71	56	45	2.2	12	.1125	●	★
0.4469			11.350	Pg7	M12x1.5	118	71	56	45	2.2	12	.1135	●	★
0.4488			11.400	1/4-18NPSC		118	71	56	45	2.2	12	.1140	●	★
0.4508			11.450		M12x1.25	118	71	56	45	2.2	12	.1145	●	★
0.4528			11.500	1/2-20UNF		118	71	56	45	2.3	12	.1150	●	★
0.4531	29/64		11.509			118	71	56	45	2.3	12	.1151	●	★
0.4567			11.600	1/2-20UNJF	M12x1	118	71	56	45	2.3	12	.1160	●	★
0.4606			11.700			118	71	56	45	2.3	12	.1170	●	★
0.4646			11.800	1/2-28UNEF	1/2-13UNC	118	71	56	45	2.3	12	.1180	●	★

Metric Shank

Standard Length
Coolant Fed

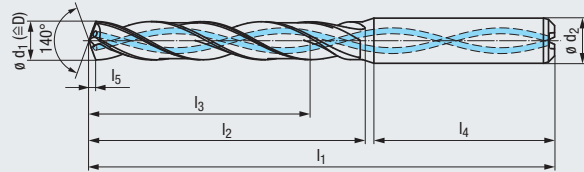

Carbide **TIALN T14**

DIN 6537 L **R30**

2 Flutes **4FF**

140° **IT9-IT10**

DIN 6535
HA HE

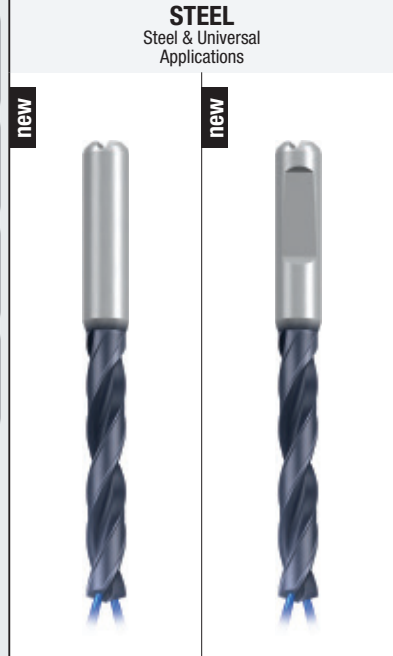

- Product Finder
- V_c / f
- STEEL
- VA
- Accessories
- Tech. Info

Applications – Material

P 1.1-5.1 **M** 1.1 **K** 1.1-4.2
N 1.1-5.2, 1-8 **S** 2.2-3 **H** 1.1-2

Drill Depth

5 x D

Tool Identification

Tool Identification												TA213344	TA513344	
Nominal Size ø d ₁ m7				Taps	Roll Form Taps	mm						Dimens. ID	EF-Drill-STEEL DIN6537L-HA IK-4FF TIALN-T14	EF-Drill-STEEL DIN6537L-HE IK-4FF TIALN-T14
inch	Fraction	Wire letter	mm			l ₁	l ₂	l ₃	l ₄	l ₅	ø d ₂ h6			
0.4685			11.900			118	71	56	45	2.3	12	.1190	●	★
0.4688	15/32		11.908			118	71	56	45	2.3	12	.1191	●	★
0.4724			12.000	M14		118	71	56	45	2.4	12	.1200	●	★
0.4783			12.150		1/2-20 UNF	124	77	60	45	2.4	14	.1215	●	★
0.4803			12.200	Tr 14x2		124	77	60	45	2.4	14	.1220	●	★
0.4844	31/64		12.304	9/16-12 UNC		124	77	60	45	2.4	14	.1230	●	★
0.4921			12.500	M14x1.5		124	77	60	45	2.4	14	.1250	●	★
0.4941			12.550		G1/4-19	124	77	60	45	2.5	14	.1255	●	★
0.5000	1/2		12.700	LK-UNC 9/16-12		124	77	60	45	2.5	14	.1270	●	★
0.5039			12.800	M14x1.25		124	77	60	45	2.5	14	.1280	●	★
0.5118			13.000	9/16-18 UNJF		124	77	60	45	2.5	14	.1300	●	★
0.5157			13.100	STI-UNF 1/2-20	M14	124	77	60	45	2.6	14	.1310	●	★
0.5236			13.300	9/16-24 UNEF	9/16-12 UNC	124	77	60	45	2.6	14	.1330	●	★
0.5256			13.350		M14x1.5	124	77	60	45	2.6	14	.1335	●	★
0.5295			13.450		M14x1.25	124	77	60	45	2.6	14	.1345	●	★
0.5313	17/32		13.495	5/8-11 UNC		124	77	60	45	2.6	14	.1349	●	★
0.5315			13.500			124	77	60	45	2.6	14	.1350	●	★
0.5374			13.650	5/8-11 UNJC	9/16-18 UNF	124	77	60	45	2.7	14	.1365	●	★
0.5394			13.700			124	77	60	45	2.7	14	.1370	●	★
0.5469	35/64		13.891			124	77	60	45	2.7	14	.1389	●	★
0.5512			14.000	M16 / M15x1		124	77	60	45	2.7	14	.1400	●	★
0.5551			14.100			133	83	63	48	2.8	16	.1410	●	★
0.5625	9/16		14.288			133	83	63	48	2.8	16	.1429	●	★
0.5709			14.500	5/8-18 UNF		133	83	63	48	2.8	16	.1450	●	★
0.5748			14.600	5/8-18 UNJF	M15x1	133	83	63	48	2.9	16	.1460	●	★
0.5781	37/64		14.684	3/8-18 NPSC		133	83	63	48	2.9	16	.1468	●	★
0.5827			14.800		5/8-11 UNC	133	83	63	48	2.9	16	.1480	●	★
0.5906			15.000	M16x1		133	83	63	48	2.9	16	.1500	●	★
0.5938	19/32		15.083			133	83	63	48	2.9	16	.1508	●	★
0.5945			15.100		M16	133	83	63	48	2.9	16	.1510	●	★
0.6102			15.500	M18		133	83	63	48	3.0	16	.1550	●	★
0.6142			15.600		M16x1	133	83	63	48	3.0	16	.1560	●	★
0.6250	5/8		15.875			133	83	63	48	3.1	16	.1588	●	★
0.6299			16.000	M18x2		133	83	63	48	3.1	16	.1600	●	★
0.6406	41/64		16.272			143	93	71	48	3.2	18	.1627	●	★
0.6496			16.500	STI-UNC 5/8-11		143	93	71	48	3.2	18	.1650	●	★
0.6563	21/32		16.669	3/4-10 UNC		143	93	71	48	3.2	18	.1667	●	★
0.6693			17.000	M18x1		143	93	71	48	3.3	18	.1700	●	★
0.6875	11/16		17.463			143	93	71	48	3.4	18	.1746	●	★
0.6890			17.500	3/4-16 UNF / M20		143	93	71	48	3.4	18	.1750	●	★
0.7087			18.000	M20x2 / LK-M16		143	93	71	48	3.5	18	.1800	●	★
0.7480			19.000	M20x1		153	101	77	50	3.7	20	.1900	●	★
0.7500	3/4		19.050			153	101	77	50	3.7	20	.1905	●	★
0.7874			20.000	M22x2	G1/2-14	153	101	77	50	3.9	20	.2000	●	★

● = In stock
★ = Allow 7 days for delivery

- Product Finder
- v_c / f
- STEEL
- VA
- Accessories
- Tech. Info

Metric Shank

Long Length Coolant Fed

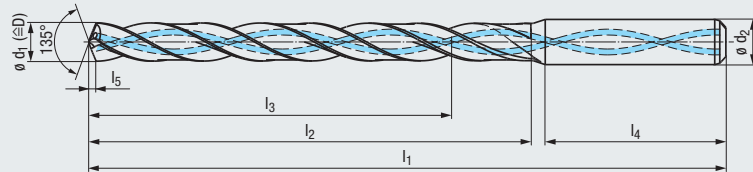

Preparatory centering with a centering drill (p.ex. EF-Drill acc. DIN 6537 K) is recommended

Carbide

TIALN T14

↓

R30

↓

2 Flutes

4FF

↓

135°

IT9-IT11

↓

DIN 6535

↓

HA

new



STEEL
Steel & Universal Applications

Applications – Material

P 1.1-5.1	M 1.1	K 1.1-4.2
N 1.1-5	N 2.1-8	S 2.2-3

Drill Depth

8 x D

Tool Identification

Nominal Size $\varnothing d_1$ m7											Taps		Roll Form Taps		mm						Dimens. ID	TA223344	
inch	Fraction	Wire letter	mm			l_1	l_2	l_3	l_4	l_5	$\varnothing d_2$ h6		EF-Drill-STEEL 8xD-HA IK-4FF TIALN-T14										
0.1102			2.800	#6-32UNC	M3	70	30	24	36	0.7	6	.0280	●										
0.1142			2.900	#6-32UNJC	#5-40UNC	70	30	24	36	0.7	6	.0290	●										
0.1150			2.920		#5-44UNF	70	30	24	36	0.7	6	.0292	●										
0.1181			3.000	#6-40UNF		78	38	30	36	0.7	6	.0300	●										
0.1220			3.100	STI-#4-40		78	38	30	36	0.7	6	.0310	●										
0.1240			3.150	M3.5x0.35	#6-32UNC	78	38	30	36	0.7	6	.0315	●										
0.1250	1/8		3.175			78	38	30	36	0.7	6	.0318	●										
0.1260			3.200	BSW ⁵ /32-32	#6-40UNF	78	38	30	36	0.7	6	.0320	●										
0.1280			3.250		M3.5	78	38	30	36	0.8	6	.0325	●										
0.1299			3.300	M4		78	38	30	36	0.8	6	.0330	●										
0.1331			3.380		M3.5x0.35	78	38	30	36	0.8	6	.0338	●										
0.1339			3.400	MJ4x0.7		78	38	30	36	0.8	6	.0340	●										
0.1378			3.500	#8-32UNC		78	38	30	36	0.8	6	.0350	●										
0.1406	9/64	#28	3.571			78	38	30	36	0.8	6	.0357	●										
0.1417			3.600	#8-36UNJF		78	38	30	36	0.8	6	.0360	●										
0.1457			3.700	M4.5	M4	78	38	30	36	0.9	6	.0370	●										
0.1496		#25	3.800	STI-#6-32	#8-32UNC	88	48	38	36	0.9	6	.0380	●										
0.1516			3.850		#8-36UNF	88	48	38	36	0.9	6	.0385	●										
0.1535			3.900	#10-24UNC		88	48	38	36	0.9	6	.0390	●										
0.1563	5/32		3.970			88	48	38	36	0.9	6	.0397	●										
0.1575			4.000	M4.5x0.5		88	48	38	36	0.9	6	.0400	●										
0.1590		#21	4.038			88	48	38	36	0.9	6	.0404	●										
0.1614			4.100	#10-32UNF		88	48	38	36	0.9	6	.0410	●										
0.1654			4.200	M5 / STI-M4	M4.5	88	48	38	36	1.0	6	.0420	●										
0.1693		#18	4.300	MJ5x0.8		88	48	38	36	1.0	6	.0430	●										
0.1713			4.350		#10-24UNC	88	48	38	36	1.0	6	.0435	●										
0.1719	11/64		4.366			88	48	38	36	1.0	6	.0437	●										
0.1732			4.400	M5x0.75		88	48	38	36	1.0	6	.0440	●										
0.1752			4.450		#10-32UNF	88	48	38	36	1.0	6	.0445	●										
0.1772			4.500	#12-24UNC		88	48	38	36	1.0	6	.0450	●										
0.1811			4.600	#12-28UNF		88	48	38	36	1.1	6	.0460	●										
0.1831			4.650	#12-24UNJC	M5	88	48	38	36	1.1	6	.0465	●										
0.1850		#13	4.700	LK-UNC#12-24		88	48	38	36	1.1	6	.0470	●										
0.1875	3/16		4.763	#12-28UNJF		97	60	48	36	1.1	6	.0476	●										
0.1890		#12	4.800	#12-32UNEF	M5x0.5 / STI-M5	97	60	48	36	1.1	6	.0480	●										
0.1929			4.900			97	60	48	36	1.1	6	.0490	●										
0.1969			5.000	M6	#12-24UNC	97	60	48	36	1.1	6	.0500	●										
0.2008			5.100	MJ6x1	#12-28UNF	97	60	48	36	1.2	6	.0510	●										
0.2010		#7	5.106			97	60	48	36	1.2	6	.0511	●										
0.2031	13/64		5.159			97	60	48	36	1.2	6	.0516	●										
0.2047			5.200	1/4-20UNC		97	60	48	36	1.2	6	.0520	●										
0.2087			5.300	1/4-20UNJC		97	60	48	36	1.2	6	.0530	●										
0.2126			5.400			97	60	48	36	1.2	6	.0540	●										
0.2130		#3	5.410			97	60	48	36	1.2	6	.0541	●										

Metric Shank

Long Length
Coolant Fed

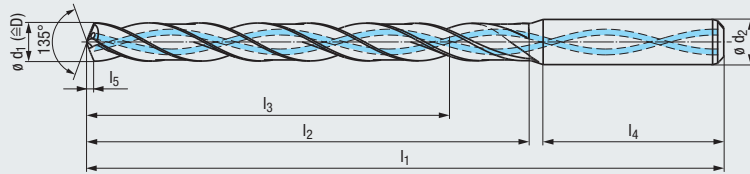

Preparatory centering with a centering drill (p.ex. EF-Drill acc. DIN 6537 K) is recommended

Carbide

TIALN T14

R30

2 Flutes

4FF

135°

IT9-IT11

DIN 6535

HA

new



STEEL
Steel & Universal
Applications

Product Finder

V_c / f

STEEL

VA

Accessories

Tech. Info

Applications – Material

P 1.1-5.1 **M** 1.1 **K** 1.1-4.2

N 1.1-5 **N** 2.1-8 **S** 2.2-3

Drill Depth

8 x D

Tool Identification

Nominal Size ø d ₁ m7										Taps			Roll Form Taps			mm				Dimens. ID	TA223344	
inch	Fraction	Wire letter	mm																			
0.2165			5.500	1/4-28 UNF				97	60	48	36	1.2	6	.0550	●							
0.2187	7/32		5.556	1/4-28 UNJF				97	60	48	36	1.3	6	.0556	●							
0.2205			5.600	1/4-32 UNEF			M6	97	60	48	36	1.3	6	.0560	●							
0.2264			5.750				1/4-20 UNC	97	60	48	36	1.3	6	.0575	●							
0.2283			5.800				M6x0.5	97	60	48	36	1.3	6	.0580	●							
0.2323			5.900					97	60	48	36	1.3	6	.0590	●							
0.2344	15/64		5.954	1/4-28 UNF				97	60	48	36	1.3	6	.0595	●							
0.2362			6.000	M7 / Rd 8x1/10				97	60	48	36	1.4	6	.0600	●							
0.2402			6.100	MJ7x1				107	70	56	36	1.4	8	.0610	●							
0.2441			6.200	M7x0.75				107	70	56	36	1.4	8	.0620	●							
0.2480			6.300	M7x0.5 / STI-M6				107	70	56	36	1.4	8	.0630	●							
0.2500	1/4	E	6.350	1/16-27 NPSF				107	70	56	36	1.4	8	.0635	●							
0.2520			6.400					107	70	56	36	1.4	8	.0640	●							
0.2559			6.500	BSW 5/16-18				107	70	56	36	1.5	8	.0650	●							
0.2570		F	6.528					107	70	56	36	1.5	8	.0653	●							
0.2598			6.600	5/16-18 UNC		M7		107	70	56	36	1.5	8	.0660	●							
0.2638			6.700	5/16-18 UNJC		M7x0.75		107	70	56	36	1.5	8	.0670	●							
0.2656	17/64		6.746					107	70	56	36	1.5	8	.0675	●							
0.2677			6.800	M8 / G 1/16				107	70	56	36	1.5	8	.0680	●							
0.2717			6.900	5/16-24 UNF				107	70	56	36	1.6	8	.0690	●							
0.2756			7.000	5/16-24 UNJF				107	70	56	36	1.6	8	.0700	●							
0.2795			7.100	MJ8x1				117	80	64	36	1.6	8	.0710	●							
0.2813	9/32	K	7.145					117	80	64	36	1.6	8	.0715	●							
0.2835			7.200	5/16-32 UNEF				117	80	64	36	1.6	8	.0720	●							
0.2854			7.250			5/16-18 UNC		117	80	64	36	1.6	8	.0725	●							
0.2874			7.300					117	80	64	36	1.6	8	.0730	●							
0.2913			7.400					117	80	64	36	1.7	8	.0740	●							
0.2933			7.450			5/16-24 UNF / M8		117	80	64	36	1.7	8	.0745	●							
0.2953			7.500	M8x0.5				117	80	64	36	1.7	8	.0750	●							
0.2969	19/64		7.541					117	80	64	36	1.7	8	.0754	●							
0.2992			7.600	Tr 9x1.5		M8x1 / STI-M8		117	80	64	36	1.7	8	.0760	●							
0.3031			7.700			M8x0.75		117	80	64	36	1.7	8	.0770	●							
0.3071			7.800	M9				117	80	64	36	1.7	8	.0780	●							
0.3110			7.900	BSW 3/8-16				117	80	64	36	1.8	8	.0790	●							
0.3125	5/16		7.938					117	80	64	36	1.8	8	.0794	●							
0.3150			8.000	3/8-16 UNC				117	80	64	36	1.8	8	.0800	●							
0.3189			8.100	3/8-16 UNJC				141	100	80	40	1.8	10	.0810	●							
0.3228			8.200	M9x0.75				141	100	80	40	1.8	10	.0820	●							
0.3268			8.300	LK-UNC 3/8-16				141	100	80	40	1.9	10	.0830	●							
0.3281	21/64		8.334					141	100	80	40	1.9	10	.0833	●							
0.3307			8.400	STI-UNC 5/16-18				141	100	80	40	1.9	10	.0840	●							
0.3346			8.500	3/8-24 UNF / M10				141	100	80	40	1.9	10	.0850	●							
0.3386			8.600	3/8-24 UNJF		M9x1		141	100	80	40	1.9	10	.0860	●							
0.3425			8.700	3/8-32 UNEF		M9x0.75		141	100	80	40	1.9	10	.0870	●							

● = In stock
★ = Allow 7 days for delivery

- Product Finder
- v_c / f
- STEEL
- VA
- Accessories
- Tech. Info

Metric Shank

Carbide

TIALN T14

R30

2 Flutes

4FF

135°

IT9-IT11

DIN 6535

HA

new

STEEL
Steel & Universal Applications



Long Length Coolant Fed

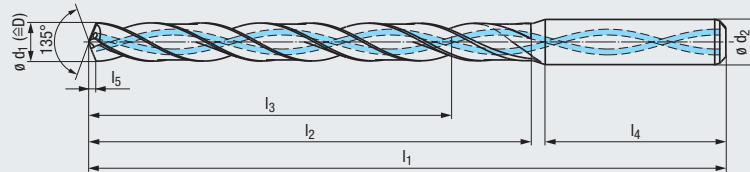

Preparatory centering with a centering drill (p.ex. EF-Drill acc. DIN 6537 K) is recommended

Applications – Material

P	1.1-5.1	M	1.1	K	1.1-4.2
N	1.1-5	N	2.1-8	S	2.2-3

Drill Depth

8 x D

Tool Identification

Tool Identification											TA223344		
Nominal Size $\varnothing d_1$ m7				Taps	Roll Form Taps	mm						Dimens. ID	EF-Drill-STEEL 8xD-HA IK-4FF TIALN-T14
inch	Fraction	Wire letter	mm			l_1	l_2	l_3	l_4	l_5	$\varnothing d_2$ h6		
0.3438	11/32		8.733	1/8-27 NPSC		141	100	80	40	1.9	10	.0873	●
0.3465			8.800	M10x1.25	3/8-16 UNC	141	100	80	40	2.0	10	.0880	●
0.3504			8.900	MJ10x1.25		141	100	80	40	2.0	10	.0890	●
0.3543			9.000	M10x1		141	100	80	40	2.0	10	.0900	●
0.3563			9.050		3/8-24 UNF	141	100	80	40	2.0	10	.0905	●
0.3583			9.100	1/8-27 NPSM		141	100	80	40	2.0	10	.0910	●
0.3594	23/64		9.129			141	100	80	40	2.0	10	.0913	●
0.3622			9.200	M10x0.75		141	100	80	40	2.1	10	.0920	●
0.3642			9.250		G 1/2-28	141	100	80	40	2.1	10	.0925	●
0.3661			9.300			141	100	80	40	2.1	10	.0930	●
0.3681			9.350		M10	141	100	80	40	2.1	10	.0935	●
0.3701			9.400	7/16-14 UNC		141	100	80	40	2.1	10	.0940	●
0.3740			9.500	7/16-14 UNJC	STI-M10	141	100	80	40	2.1	10	.0950	●
0.3750	3/8		9.525			141	100	80	40	2.1	10	.0953	●
0.3780			9.600		M10x1	141	100	80	40	2.1	10	.0960	●
0.3819			9.700	LK-UNC 7/16-14	M10x0.75	141	100	80	40	2.2	10	.0970	●
0.3858			9.800	STI-UNF 3/8-24		141	100	80	40	2.2	10	.0980	●
0.3898			9.900	7/16-20 UNF		141	100	80	40	2.2	10	.0990	●
0.3906	25/64		9.921			141	100	80	40	2.2	10	.0992	●
0.3937			10.000	7/16-20 UNJF		141	100	80	40	2.2	10	.1000	●
0.3976			10.100			166	120	96	45	2.2	12	.1010	●
0.4016			10.200	7/16-28 UNEF		166	120	96	45	2.3	12	.1020	●
0.4035			10.250		7/16-14 UNC	166	120	96	45	2.3	12	.1025	●
0.4055			10.300			166	120	96	45	2.3	12	.1030	●
0.4063	13/32		10.320			166	120	96	45	2.3	12	.1032	●
0.4134			10.500	M12x1.5		166	120	96	45	2.3	12	.1050	●
0.4154			10.550		7/16-20 UNF	166	120	96	45	2.3	12	.1055	●
0.4213			10.700	LK-M12		166	120	96	45	2.4	12	.1070	●
0.4219	27/64		10.716	1/2-13 UNC		166	120	96	45	2.4	12	.1072	●
0.4252			10.800	M12x1.25		166	120	96	45	2.4	12	.1080	●
0.4291			10.900	1/2-13 UNJC		166	120	96	45	2.4	12	.1090	●
0.4331			11.000	M12x1		166	120	96	45	2.4	12	.1100	●
0.4370			11.100	BSF 1/2-16		166	120	96	45	2.5	12	.1110	●
0.4375	7/16		11.113	LK-UNC 1/2-13		166	120	96	45	2.5	12	.1111	●
0.4409			11.200			166	120	96	45	2.5	12	.1120	●
0.4429			11.250	M12x0.75	M12	166	120	96	45	2.5	12	.1125	●
0.4469			11.350	Pg 7	M12x1.5	166	120	96	45	2.5	12	.1135	●
0.4488			11.400	1/4-18 NPSC		166	120	96	45	2.5	12	.1140	●
0.4508			11.450		M12x1.25	166	120	96	45	2.5	12	.1145	●
0.4528			11.500	1/2-20 UNF		166	120	96	45	2.6	12	.1150	●
0.4531	29/64		11.509			166	120	96	45	2.6	12	.1151	●
0.4567			11.600	1/2-20 UNJF	M12x1	166	120	96	45	2.6	12	.1160	●
0.4606			11.700			166	120	96	45	2.6	12	.1170	●
0.4646			11.800	1/2-28 UNEF	1/2-13 UNC	166	120	96	45	2.6	12	.1180	●

Metric Shank

Long Length
Coolant Fed

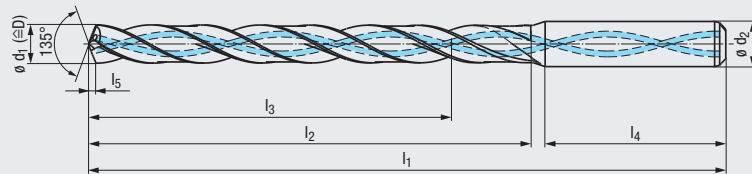

Preparatory centering with a centering drill (p.ex. EF-Drill acc. DIN 6537 K) is recommended

Carbide

TIALN
T14

new

R30

2 Flutes

4FF

135°

IT9-IT11

DIN 6535

HA

STEEL
Steel & Universal
Applications



Product
Finder

V_c / f

STEEL

VA

Accessories

Tech. Info

Applications – Material

P	1.1-5.1	M	1.1	K	1.1-4.2
N	1.1-5	N	2.1-8	S	2.2-3

Drill Depth

8 x D

Tool Identification

Nominal Size ø d ₁ m7										Taps			Roll Form Taps			mm			Dimens. ID	TA223344	
inch	Fraction	Wire letter	mm			l ₁	l ₂	l ₃	l ₄	l ₅	ø d ₂ h6										
0.4685			11.900			166	120	96	45	2.6	12	.1190	●								
0.4688	15/32		11.908			166	120	96	45	2.6	12	.1191	●								
0.4724			12.000		M14	166	120	96	45	2.7	12	.1200	●								
0.4783			12.150			186	140	112	45	2.7	14	.1215	●								
0.4803			12.200		Tr 14x2	186	140	112	45	2.7	14	.1220	●								
0.4844	31/64		12.304		9/16-12 UNC	186	140	112	45	2.7	14	.1230	●								
0.4921			12.500		M14x1.5	186	140	112	45	2.8	14	.1250	●								
0.4941			12.550			G1/4-19	186	140	112	45	2.8	14	.1255	●							
0.5000	1/2		12.700		LK-UNC 9/16-12	186	140	112	45	2.8	14	.1270	●								
0.5039			12.800		M14x1.25	186	140	112	45	2.8	14	.1280	●								
0.5118			13.000		9/16-18 UNJF	186	140	112	45	2.9	14	.1300	●								
0.5157			13.100		STI-UNF 1/2-20	M14	186	140	112	45	2.9	14	.1310	●							
0.5236			13.300		9/16-24 UNEF	9/16-12 UNC	186	140	112	45	2.9	14	.1330	●							
0.5256			13.350			M14x1.5	186	140	112	45	3.0	14	.1335	●							
0.5295			13.450			M14x1.25	186	140	112	45	3.0	14	.1345	●							
0.5313	17/32		13.495		5/8-11 UNC	186	140	112	45	3.0	14	.1349	●								
0.5315			13.500				186	140	112	45	3.0	14	.1350	●							
0.5374			13.650		5/8-11 UNJC	9/16-18 UNF	186	140	112	45	3.0	14	.1365	●							
0.5394			13.700				186	140	112	45	3.0	14	.1370	●							
0.5469	35/64		13.891				186	140	112	45	3.1	14	.1389	●							
0.5512			14.000		M16 / M15x1		186	140	112	45	3.1	14	.1400	●							
0.5551			14.100				209	160	128	48	3.1	16	.1410	●							
0.5625	9/16		14.288				209	160	128	48	3.2	16	.1429	●							
0.5709			14.500		5/8-18 UNF		209	160	128	48	3.2	16	.1450	●							
0.5748			14.600		5/8-18 UNJF	M15x1	209	160	128	48	3.2	16	.1460	●							
0.5781	37/64		14.684		3/8-18 NPSC		209	160	128	48	3.2	16	.1468	●							
0.5827			14.800			5/8-11 UNC	209	160	128	48	3.3	16	.1480	●							
0.5906			15.000		M16x1		209	160	128	48	3.3	16	.1500	●							
0.5938	19/32		15.083				209	160	128	48	3.3	16	.1508	●							
0.5945			15.100			M16	209	160	128	48	3.3	16	.1510	●							
0.6102			15.500		M18		209	160	128	48	3.4	16	.1550	●							
0.6142			15.600			M16x1	209	160	128	48	3.4	16	.1560	●							
0.6250	5/8		15.875				209	160	128	48	3.5	16	.1588	●							
0.6299			16.000		M18x2		209	160	128	48	3.5	16	.1600	●							
0.6406	41/64		16.272				229	180	144	48	3.6	18	.1627	●							
0.6496			16.500		STI-UNC 5/8-11		229	180	144	48	3.6	18	.1650	●							
0.6563	21/32		16.669		3/4-10 UNC		229	180	144	48	3.7	18	.1667	●							
0.6693			17.000		M18x1		229	180	144	48	3.7	18	.1700	●							
0.6875	11/16		17.463				229	180	144	48	3.8	18	.1746	●							
0.6890			17.500		3/4-16 UNF / M20		229	180	144	48	3.9	18	.1750	●							
0.7087			18.000		M20x2 / LK-M16		229	180	144	48	4.0	18	.1800	●							
0.7480			19.000		M20x1		251	200	160	50	4.2	20	.1900	●							
0.7500	3/4		19.050				251	200	160	50	4.2	20	.1905	●							
0.7874			20.000		M22x2	G1/2-14	251	200	160	50	4.4	20	.2000	●							

● = In stock
★ = Allow 7 days for delivery

- Product Finder
- v_c / f
- STEEL
- VA
- Accessories
- Tech. Info

Metric Shank

For the machining of stainless steel materials

Stub Length
Coolant Fed

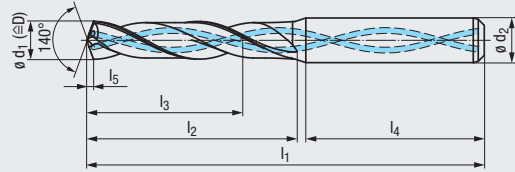

Carbide

ALCR T37

DIN 6537 K

R30

2 Flutes

2FF

140°

IT9-IT10

DIN 6535

HA
HE

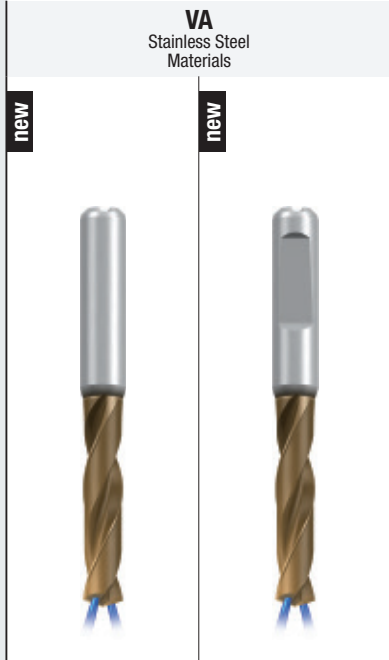

Applications – Material

M 1.1-4.1

S 1.1-3

S 2.2-4, 2.6

N 1.1-3

Drill Depth

3 x D

Tool Identification

										TA204524		TA504524		
Nominal Size ø d ₁ m7				Taps	Roll Form Taps	mm					Dimens. ID	EF-Drill-VA DIN6537K-HA IK-2FF ALCR-T37	EF-Drill-VA DIN6537K-HE IK-2FF ALCR-T37	
inch	Fraction	Wire letter	mm			l ₁	l ₂	l ₃	l ₄	l ₅	ø d ₂ h6			
0.1102			2.800	#6-32UNC	M3	57	16	11	36	0.6	6	.0280	●	★
0.1142			2.900	#6-32UNJC	#5-40UNC	57	16	11	36	0.6	6	.0290	●	★
0.1150			2.920		#5-44 UNF	57	16	11	36	0.6	6	.0292	●	★
0.1181			3.000	#6-40 UNF		62	20	14	36	0.6	6	.0300	●	★
0.1220			3.100	STI-#4-40		62	20	14	36	0.6	6	.0310	●	★
0.1240			3.150	M3.5x0.35	#6-32UNC	62	20	14	36	0.7	6	.0315	●	★
0.1250	1/8		3.175			62	20	14	36	0.7	6	.0318	●	★
0.1260			3.200	BSW ⁵ /32-32	#6-40 UNF	62	20	14	36	0.7	6	.0320	●	★
0.1280			3.250		M3.5	62	20	14	36	0.7	6	.0325	●	★
0.1299			3.300	M4		62	20	14	36	0.7	6	.0330	●	★
0.1331			3.380		M3.5x0.35	62	20	14	36	0.7	6	.0338	●	★
0.1339			3.400	MJ4x0.7		62	20	14	36	0.7	6	.0340	●	★
0.1378			3.500	#8-32UNC		62	20	14	36	0.7	6	.0350	●	★
0.1406	9/64	#28	3.571			62	20	14	36	0.7	6	.0357	●	★
0.1417			3.600	#8-36 UNJF		62	20	14	36	0.7	6	.0360	●	★
0.1457			3.700	M4.5	M4	62	20	14	36	0.8	6	.0370	●	★
0.1496		#25	3.800	STI-#6-32	#8-32UNC	66	24	17	36	0.8	6	.0380	●	★
0.1516			3.850		#8-36 UNF	66	24	17	36	0.8	6	.0385	●	★
0.1535			3.900	#10-24 UNC		66	24	17	36	0.8	6	.0390	●	★
0.1563	5/32		3.970			66	24	17	36	0.8	6	.0397	●	★
0.1575			4.000	M4.5x0.5		66	24	17	36	0.8	6	.0400	●	★
0.1590		#21	4.038			66	24	17	36	0.8	6	.0404	●	★
0.1614			4.100	#10-32 UNF		66	24	17	36	0.8	6	.0410	●	★
0.1654			4.200	M5 / STI-M4	M4.5	66	24	17	36	0.9	6	.0420	●	★
0.1693		#18	4.300	MJ5x0.8		66	24	17	36	0.9	6	.0430	●	★
0.1713			4.350		#10-24 UNC	66	24	17	36	0.9	6	.0435	●	★
0.1719	11/64		4.366			66	24	17	36	0.9	6	.0437	●	★
0.1732			4.400	M5x0.75		66	24	17	36	0.9	6	.0440	●	★
0.1752			4.450		#10-32 UNF	66	24	17	36	0.9	6	.0445	●	★
0.1772			4.500	#12-24 UNC		66	24	17	36	0.9	6	.0450	●	★
0.1811			4.600	#12-28 UNF		66	24	17	36	0.9	6	.0460	●	★
0.1831			4.650	#12-24 UNJC	M5	66	24	17	36	0.9	6	.0465	●	★
0.1850		#13	4.700	LK-UNC#12-24		66	24	17	36	1.0	6	.0470	●	★
0.1875	3/16		4.763	#12-28 UNJF		66	28	20	36	1.0	6	.0476	●	★
0.1890		#12	4.800	#12-32 UNEF	M5x0.5 / STI-M5	66	28	20	36	1.0	6	.0480	●	★
0.1929			4.900			66	28	20	36	1.0	6	.0490	●	★
0.1969			5.000	M6	#12-24 UNC	66	28	20	36	1.0	6	.0500	●	★
0.2008			5.100	MJ6x1	#12-28 UNF	66	28	20	36	1.0	6	.0510	●	★
0.2010		#7	5.106			66	28	20	36	1.0	6	.0511	●	★
0.2031	13/64		5.159			66	28	20	36	1.0	6	.0516	●	★
0.2047			5.200	1/4-20 UNC		66	28	20	36	1.0	6	.0520	●	★
0.2087			5.300	1/4-20 UNJC		66	28	20	36	1.1	6	.0530	●	★
0.2126			5.400			66	28	20	36	1.1	6	.0540	●	★
0.2130		#3	5.410			66	28	20	36	1.1	6	.0541	●	★

Metric Shank

For the machining of stainless steel materials

Stub Length
Coolant Fed

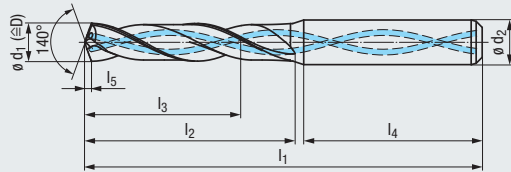

Carbide **ALCR T37**

DIN 6537 K **R30**

2 Flutes **2FF**

140° **IT9-IT10**

DIN 6535
HA HE

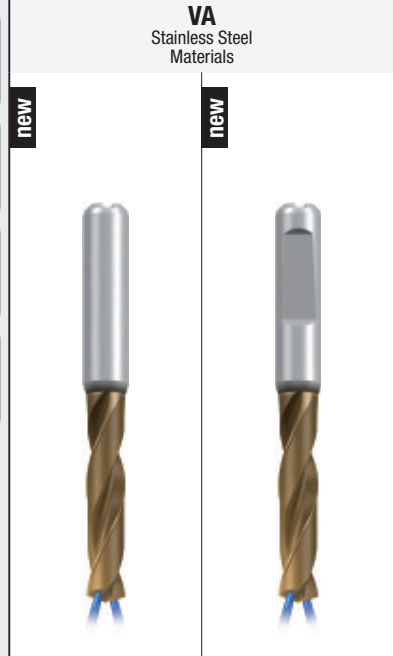

- Product Finder
- Vc / f
- STEEL
- VA
- Accessories
- Tech. Info

Applications – Material

M 1.1-4.1 S 1.1-3 S 2.2-4, 2.6
N 1.1-3

Drill Depth

3 x D

Tool Identification

Tool Identification													TA204524	TA504524	
Nominal Size ø d ₁ m7				Taps	Roll Form Taps	mm							Dimens. ID	EF-Drill-VA DIN6537K-HA IK-2FF ALCR-T37	EF-Drill-VA DIN6537K-HE IK-2FF ALCR-T37
inch	Fraction	Wire letter	mm			l ₁	l ₂	l ₃	l ₄	l ₅	ø d ₂ h6				
0.2165			5.500	1/4-28 UNF		66	28	20	36	1.1	6	.0550	●	★	
0.2187	7/32		5.556	1/4-28 UNJF		66	28	20	36	1.1	6	.0556	●	★	
0.2205			5.600	1/4-32 UNEF	M6	66	28	20	36	1.1	6	.0560	●	★	
0.2264			5.750		1/4-20 UNC	66	28	20	36	1.2	6	.0575	●	★	
0.2283			5.800		M6x0.5	66	28	20	36	1.2	6	.0580	●	★	
0.2323			5.900			66	28	20	36	1.2	6	.0590	●	★	
0.2344	15/64		5.954		1/4-28 UNF	66	28	20	36	1.2	6	.0595	●	★	
0.2362			6.000	M7 / Rd8x1/10		66	28	20	36	1.2	6	.0600	●	★	
0.2402			6.100	MJ7x1		79	34	24	36	1.2	8	.0610	●	★	
0.2441			6.200	M7x0.75		79	34	24	36	1.2	8	.0620	●	★	
0.2480			6.300	M7x0.5 / STI-M6		79	34	24	36	1.3	8	.0630	●	★	
0.2500	1/4	E	6.350	1/16-27 NPSF		79	34	24	36	1.3	8	.0635	●	★	
0.2520			6.400			79	34	24	36	1.3	8	.0640	●	★	
0.2559			6.500	BSW 5/16-18		79	34	24	36	1.3	8	.0650	●	★	
0.2570		F	6.528			79	34	24	36	1.3	8	.0653	●	★	
0.2598			6.600	5/16-18 UNC	M7	79	34	24	36	1.3	8	.0660	●	★	
0.2638			6.700	5/16-18 UNJC	M7x0.75	79	34	24	36	1.3	8	.0670	●	★	
0.2656	17/64		6.746			79	34	24	36	1.3	8	.0675	●	★	
0.2677			6.800	M8 / G 1/16		79	34	24	36	1.4	8	.0680	●	★	
0.2717			6.900	5/16-24 UNF		79	34	24	36	1.4	8	.0690	●	★	
0.2756			7.000	5/16-24 UNJF		79	34	24	36	1.4	8	.0700	●	★	
0.2795			7.100	MJ8x1		79	41	29	36	1.4	8	.0710	●	★	
0.2813	9/32	K	7.145			79	41	29	36	1.4	8	.0715	●	★	
0.2835			7.200	5/16-32 UNEF		79	41	29	36	1.4	8	.0720	●	★	
0.2854			7.250		5/16-18 UNC	79	41	29	36	1.4	8	.0725	●	★	
0.2874			7.300			79	41	29	36	1.5	8	.0730	●	★	
0.2913			7.400			79	41	29	36	1.5	8	.0740	●	★	
0.2933			7.450		5/16-24 UNF / M8	79	41	29	36	1.5	8	.0745	●	★	
0.2953			7.500	M8x0.5		79	41	29	36	1.5	8	.0750	●	★	
0.2969	19/64		7.541			79	41	29	36	1.5	8	.0754	●	★	
0.2992			7.600	Tr9x1.5	M8x1 / STI-M8	79	41	29	36	1.5	8	.0760	●	★	
0.3031			7.700		M8x0.75	79	41	29	36	1.5	8	.0770	●	★	
0.3071			7.800	M9		79	41	29	36	1.5	8	.0780	●	★	
0.3110			7.900	BSW 3/8-16		79	41	29	36	1.6	8	.0790	●	★	
0.3125	5/16		7.938			79	41	29	36	1.6	8	.0794	●	★	
0.3150			8.000	3/8-16 UNC		79	41	29	36	1.6	8	.0800	●	★	
0.3189			8.100	3/8-16 UNJC		89	47	35	40	1.6	10	.0810	●	★	
0.3228			8.200	M9x0.75		89	47	35	40	1.6	10	.0820	●	★	
0.3268			8.300	LK-UNC 3/8-16		89	47	35	40	1.6	10	.0830	●	★	
0.3281	21/64		8.334			89	47	35	40	1.6	10	.0833	●	★	
0.3307			8.400	STI-UNC 5/16-18		89	47	35	40	1.7	10	.0840	●	★	
0.3346			8.500	3/8-24 UNF / M10		89	47	35	40	1.7	10	.0850	●	★	
0.3386			8.600	3/8-24 UNJF	M9x1	89	47	35	40	1.7	10	.0860	●	★	
0.3425			8.700	3/8-32 UNEF	M9x0.75	89	47	35	40	1.7	10	.0870	●	★	

● = In stock
★ = Allow 7 days for delivery

- Product Finder
- v_c / f
- STEEL
- VA
- Accessories
- Tech. Info

Metric Shank

For the machining of stainless steel materials

Stub Length
Coolant Fed

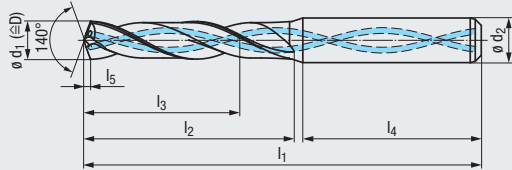

Carbide

ALCR T37

DIN 6537 K

R30

2 Flutes

2FF

140°

IT9-IT10

DIN 6535

HA
HE

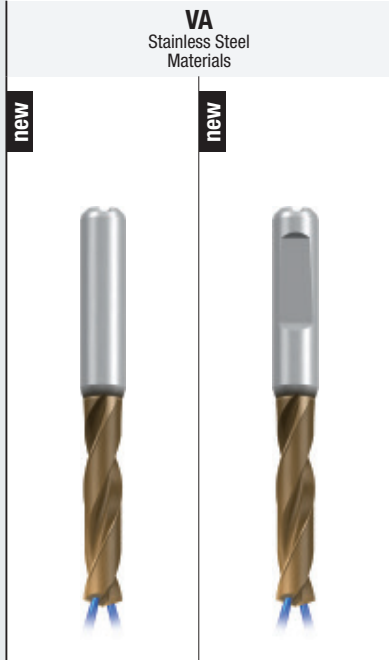

Applications – Material

M 1.1-4.1

S 1.1-3

S 2.2-4, 2.6

N 1.1-3

Drill Depth

3 x D

Tool Identification

										TA204524		TA504524		
Nominal Size ϕd_1 m7				Taps	Roll Form Taps	mm					Dimens. ID	EF-Drill-VA DIN6537K- IK-2FF ALCR-T37	EF-Drill-VA DIN6537K- HE IK-2FF ALCR-T37	
inch	Fraction	Wire letter	mm			l_1	l_2	l_3	l_4	l_5	ϕd_2 h6			
0.3438	11/32		8.733	1/8-27 NPSC		89	47	35	40	1.7	10	.0873	●	★
0.3465			8.800	M10x1.25	3/8-16 UNC	89	47	35	40	1.7	10	.0880	●	★
0.3504			8.900	MJ10x1.25		89	47	35	40	1.8	10	.0890	●	★
0.3543			9.000	M10x1		89	47	35	40	1.8	10	.0900	●	★
0.3563			9.050		3/8-24 UNF	89	47	35	40	1.8	10	.0905	●	★
0.3583			9.100	1/8-27 NPSM		89	47	35	40	1.8	10	.0910	●	★
0.3594	23/64		9.129			89	47	35	40	1.8	10	.0913	●	★
0.3622			9.200	M10x0.75		89	47	35	40	1.8	10	.0920	●	★
0.3642			9.250		G 1/2-28	89	47	35	40	1.8	10	.0925	●	★
0.3661			9.300			89	47	35	40	1.8	10	.0930	●	★
0.3681			9.350		M10	89	47	35	40	1.8	10	.0935	●	★
0.3701			9.400	7/16-14 UNC		89	47	35	40	1.9	10	.0940	●	★
0.3740			9.500	7/16-14 UNJC	STI-M10	89	47	35	40	1.9	10	.0950	●	★
0.3750	3/8		9.525			89	47	35	40	1.9	10	.0953	●	★
0.3780			9.600		M10x1	89	47	35	40	1.9	10	.0960	●	★
0.3819			9.700	LK-UNC 7/16-14	M10x0.75	89	47	35	40	1.9	10	.0970	●	★
0.3858			9.800	STI-UNF 3/8-24		89	47	35	40	1.9	10	.0980	●	★
0.3898			9.900	7/16-20 UNF		89	47	35	40	2.0	10	.0990	●	★
0.3906	25/64		9.921			89	47	35	40	2.0	10	.0992	●	★
0.3937			10.000	7/16-20 UNJF		89	47	35	40	2.0	10	.1000	●	★
0.3976			10.100			102	55	40	45	2.0	12	.1010	●	★
0.4016			10.200	7/16-28 UNEF		102	55	40	45	2.0	12	.1020	●	★
0.4035			10.250		7/16-14 UNC	102	55	40	45	2.0	12	.1025	●	★
0.4055			10.300			102	55	40	45	2.0	12	.1030	●	★
0.4063	13/32		10.320			102	55	40	45	2.0	12	.1032	●	★
0.4134			10.500	M12x1.5		102	55	40	45	2.1	12	.1050	●	★
0.4154			10.550		7/16-20 UNF	102	55	40	45	2.1	12	.1055	●	★
0.4213			10.700	LK-M12		102	55	40	45	2.1	12	.1070	●	★
0.4219	27/64		10.716	1/2-13 UNC		102	55	40	45	2.1	12	.1072	●	★
0.4252			10.800	M12x1.25		102	55	40	45	2.1	12	.1080	●	★
0.4291			10.900	1/2-13 UNJC		102	55	40	45	2.1	12	.1090	●	★
0.4331			11.000	M12x1		102	55	40	45	2.2	12	.1100	●	★
0.4370			11.100	BSF 1/2-16		102	55	40	45	2.2	12	.1110	●	★
0.4375	7/16		11.113	LK-UNC 1/2-13		102	55	40	45	2.2	12	.1111	●	★
0.4409			11.200			102	55	40	45	2.2	12	.1120	●	★
0.4429			11.250	M12x0.75	M12	102	55	40	45	2.2	12	.1125	●	★
0.4469			11.350	Pg7	M12x1.5	102	55	40	45	2.2	12	.1135	●	★
0.4488			11.400	1/4-18 NPSC		102	55	40	45	2.2	12	.1140	●	★
0.4508			11.450		M12x1.25	102	55	40	45	2.2	12	.1145	●	★
0.4528			11.500	1/2-20 UNF		102	55	40	45	2.3	12	.1150	●	★
0.4531	29/64		11.509			102	55	40	45	2.3	12	.1151	●	★
0.4567			11.600	1/2-20 UNJF	M12x1	102	55	40	45	2.3	12	.1160	●	★
0.4606			11.700			102	55	40	45	2.3	12	.1170	●	★
0.4646			11.800	1/2-28 UNEF	1/2-13 UNC	102	55	40	45	2.3	12	.1180	●	★

Metric Shank

For the machining of stainless steel materials

Stub Length
Coolant Fed

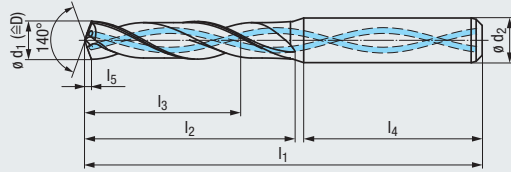

Carbide **ALCR T37**

DIN 6537 K **R30**

2 Flutes **2FF**

140° **IT9-IT10**

DIN 6535
HA HE

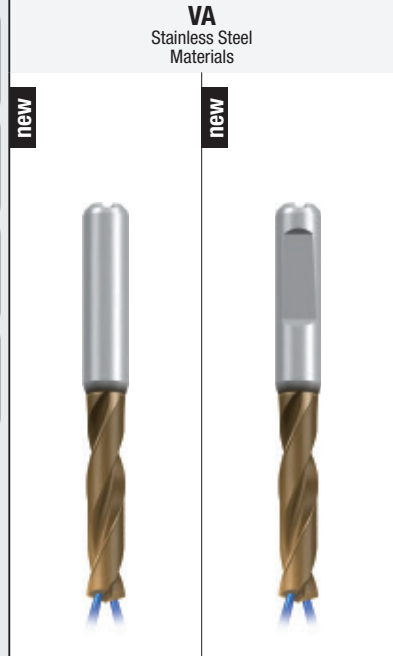

Product Finder

Vc / f

STEEL

VA

Accessories

Tech. Info

Applications – Material

M 1.1-4.1 **S** 1.1-3 **S** 2.2-4, 2.6
N 1.1-3

Drill Depth

3 x D

Tool Identification

Tool Identification												TA204524	TA504524	
Nominal Size ø d1 m7				Taps	Roll Form Taps	mm						Dimens. ID	EF-Drill-VA DIN6537K-HA IK-2FF ALCR-T37	EF-Drill-VA DIN6537K-HE IK-2FF ALCR-T37
inch	Fraction	Wire letter	mm			l1	l2	l3	l4	l5	ø d2 h6			
0.4685			11.900			102	55	40	45	2.3	12	.1190	●	★
0.4688	15/32		11.908			102	55	40	45	2.3	12	.1191	●	★
0.4724			12.000	M14		102	55	40	45	2.4	12	.1200	●	★
0.4783			12.150		1/2-20 UNF	107	60	43	45	2.4	14	.1215	●	★
0.4803			12.200	Tr 14x2		107	60	43	45	2.4	14	.1220	●	★
0.4844	31/64		12.304	9/16-12 UNC		107	60	43	45	2.4	14	.1230	●	★
0.4921			12.500	M14x1.5		107	60	43	45	2.4	14	.1250	●	★
0.4941			12.550		G1/4-19	107	60	43	45	2.5	14	.1255	●	★
0.5000	1/2		12.700	LK-UNC 9/16-12		107	60	43	45	2.5	14	.1270	●	★
0.5039			12.800	M14x1.25		107	60	43	45	2.5	14	.1280	●	★
0.5118			13.000	9/16-18 UNJF		107	60	43	45	2.5	14	.1300	●	★
0.5157			13.100	STI-UNF 1/2-20	M14	107	60	43	45	2.6	14	.1310	●	★
0.5236			13.300	9/16-24 UNEF	9/16-12 UNC	107	60	43	45	2.6	14	.1330	●	★
0.5256			13.350		M14x1.5	107	60	43	45	2.6	14	.1335	●	★
0.5295			13.450		M14x1.25	107	60	43	45	2.6	14	.1345	●	★
0.5313	17/32		13.495	5/8-11 UNC		107	60	43	45	2.6	14	.1349	●	★
0.5315			13.500			107	60	43	45	2.6	14	.1350	●	★
0.5374			13.650	5/8-11 UNJC	9/16-18 UNF	107	60	43	45	2.7	14	.1365	●	★
0.5394			13.700			107	60	43	45	2.7	14	.1370	●	★
0.5469	35/64		13.891			107	60	43	45	2.7	14	.1389	●	★
0.5512			14.000	M16 / M15x1		107	60	43	45	2.7	14	.1400	●	★
0.5551			14.100			115	65	45	48	2.8	16	.1410	●	★
0.5625	9/16		14.288			115	65	45	48	2.8	16	.1429	●	★
0.5709			14.500	5/8-18 UNF		115	65	45	48	2.8	16	.1450	●	★
0.5748			14.600	5/8-18 UNJF	M15x1	115	65	45	48	2.9	16	.1460	●	★
0.5781	37/64		14.684	3/8-18 NPSC		115	65	45	48	2.9	16	.1468	●	★
0.5827			14.800		5/8-11 UNC	115	65	45	48	2.9	16	.1480	●	★
0.5906			15.000	M16x1		115	65	45	48	2.9	16	.1500	●	★
0.5938	19/32		15.083			115	65	45	48	2.9	16	.1508	●	★
0.5945			15.100		M16	115	65	45	48	2.9	16	.1510	●	★
0.6102			15.500	M18		115	65	45	48	3.0	16	.1550	●	★
0.6142			15.600		M16x1	115	65	45	48	3.0	16	.1560	●	★
0.6250	5/8		15.875			115	65	45	48	3.1	16	.1588	●	★
0.6299			16.000	M18x2		115	65	45	48	3.1	16	.1600	●	★
0.6406	41/64		16.272			123	73	51	48	3.2	18	.1627	●	★
0.6496			16.500	STI-UNC 5/8-11		123	73	51	48	3.2	18	.1650	●	★
0.6563	21/32		16.669	3/4-10 UNC		123	73	51	48	3.2	18	.1667	●	★
0.6693			17.000	M18x1		123	73	51	48	3.3	18	.1700	●	★
0.6875	11/16		17.463			123	73	51	48	3.4	18	.1746	●	★
0.6890			17.500	3/4-16 UNF / M20		123	73	51	48	3.4	18	.1750	●	★
0.7087			18.000	M20x2 / LK-M16		123	73	51	48	3.5	18	.1800	●	★
0.7480			19.000	M20x1		131	79	55	50	3.7	20	.1900	●	★
0.7500	3/4		19.050			131	79	55	50	3.7	20	.1905	●	★
0.7874			20.000	M22x2	G1/2-14	131	79	55	50	3.9	20	.2000	●	★

● = In stock
★ = Allow 7 days for delivery

- Product Finder
- v_c / f
- STEEL
- VA
- Accessories
- Tech. Info

Metric Shank

For the machining of stainless steel materials

Standard Length
Coolant Fed

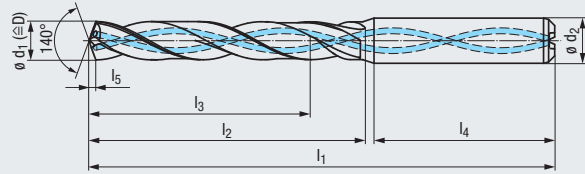

Carbide

ALCR
T37

DIN
6537 L

R30

2 Flutes



2FF



140°



IT9-IT10

DIN 6535

HA

HE

VA
Stainless Steel
Materials

new



new



Applications – Material

M 1.1-4.1 S 1.1-3 S 2.2-4, 2.6

Drill Depth

5 x D

Tool Identification

										TA214524		TA514524		
Nominal Size ϕd_1 m7				Taps	Roll Form Taps	mm					Dimens. ID	EF-Drill-VA DIN6537L-HA IK-2FF ALCR-T37	EF-Drill-VA DIN6537L-HE IK-2FF ALCR-T37	
inch	Fraction	Wire letter	mm			l_1	l_2	l_3	l_4	l_5	ϕd_2 h6			
0.1102			2.800	#6-32UNC	M3	61	22	17	36	0.6	6	.0280	●	★
0.1142			2.900	#6-32UNJC	#5-40UNC	61	22	17	36	0.6	6	.0290	●	★
0.1150			2.920		#5-44UNF	61	22	17	36	0.6	6	.0292	●	★
0.1181			3.000	#6-40UNF		66	28	23	36	0.6	6	.0300	●	★
0.1220			3.100	STI-#4-40		66	28	23	36	0.6	6	.0310	●	★
0.1240			3.150	M3.5x0.35	#6-32UNC	66	28	23	36	0.7	6	.0315	●	★
0.1250	1/8		3.175			66	28	23	36	0.7	6	.0318	●	★
0.1260			3.200	BSW ⁵ /32-32	#6-40UNF	66	28	23	36	0.7	6	.0320	●	★
0.1280			3.250		M3.5	66	28	23	36	0.7	6	.0325	●	★
0.1299			3.300	M4		66	28	23	36	0.7	6	.0330	●	★
0.1331			3.380		M3.5x0.35	66	28	23	36	0.7	6	.0338	●	★
0.1339			3.400	MJ4x0.7		66	28	23	36	0.7	6	.0340	●	★
0.1378			3.500	#8-32UNC		66	28	23	36	0.7	6	.0350	●	★
0.1406	9/64	#28	3.571			66	28	23	36	0.7	6	.0357	●	★
0.1417			3.600	#8-36UNJF		66	28	23	36	0.7	6	.0360	●	★
0.1457			3.700	M4.5	M4	66	28	23	36	0.8	6	.0370	●	★
0.1496		#25	3.800	STI-#6-32	#8-32UNC	74	36	29	36	0.8	6	.0380	●	★
0.1516			3.850		#8-36UNF	74	36	29	36	0.8	6	.0385	●	★
0.1535			3.900	#10-24UNC		74	36	29	36	0.8	6	.0390	●	★
0.1563	5/32		3.970			74	36	29	36	0.8	6	.0397	●	★
0.1575			4.000	M4.5x0.5		74	36	29	36	0.8	6	.0400	●	★
0.1590		#21	4.038			74	36	29	36	0.8	6	.0404	●	★
0.1614			4.100	#10-32UNF		74	36	29	36	0.8	6	.0410	●	★
0.1654			4.200	M5 / STI-M4	M4.5	74	36	29	36	0.9	6	.0420	●	★
0.1693		#18	4.300	MJ5x0.8		74	36	29	36	0.9	6	.0430	●	★
0.1713			4.350		#10-24UNC	74	36	29	36	0.9	6	.0435	●	★
0.1719	11/64		4.366			74	36	29	36	0.9	6	.0437	●	★
0.1732			4.400	M5x0.75		74	36	29	36	0.9	6	.0440	●	★
0.1752			4.450		#10-32UNF	74	36	29	36	0.9	6	.0445	●	★
0.1772			4.500	#12-24UNC		74	36	29	36	0.9	6	.0450	●	★
0.1811			4.600	#12-28UNF		74	36	29	36	0.9	6	.0460	●	★
0.1831			4.650	#12-24UNJC	M5	74	36	29	36	0.9	6	.0465	●	★
0.1850		#13	4.700	LK-UNC#12-24		74	36	29	36	1.0	6	.0470	●	★
0.1875	3/16		4.763	#12-28UNJF		82	44	35	36	1.0	6	.0476	●	★
0.1890		#12	4.800	#12-32UNEF	M5x0.5 / STI-M5	82	44	35	36	1.0	6	.0480	●	★
0.1929			4.900			82	44	35	36	1.0	6	.0490	●	★
0.1969			5.000	M6	#12-24UNC	82	44	35	36	1.0	6	.0500	●	★
0.2008			5.100	MJ6x1	#12-28UNF	82	44	35	36	1.0	6	.0510	●	★
0.2010		#7	5.106			82	44	35	36	1.0	6	.0511	●	★
0.2031	13/64		5.159			82	44	35	36	1.0	6	.0516	●	★
0.2047			5.200	1/4-20UNC		82	44	35	36	1.0	6	.0520	●	★
0.2087			5.300	1/4-20UNJC		82	44	35	36	1.1	6	.0530	●	★
0.2126			5.400			82	44	35	36	1.1	6	.0540	●	★
0.2130		#3	5.410			82	44	35	36	1.1	6	.0541	●	★

Metric Shank

For the machining of stainless steel materials

Standard Length
Coolant Fed

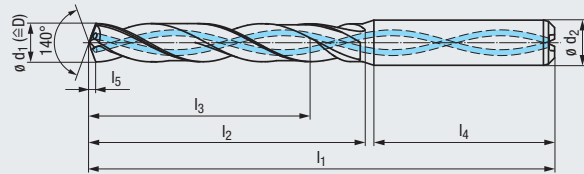

Carbide **ALCR T37**

DIN 6537 L **R30**

2 Flutes **2FF**

140° **IT9-IT10**

DIN 6535
HA HE

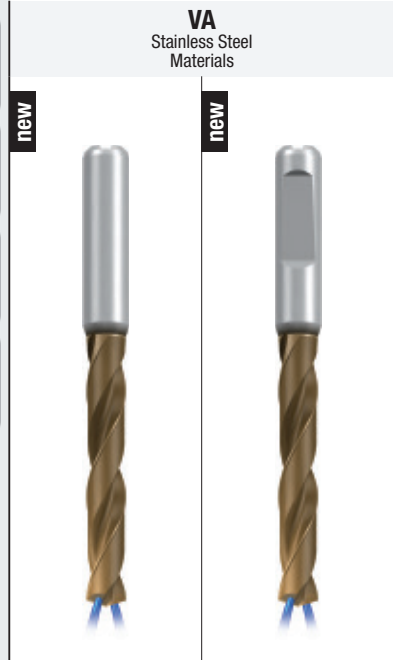

- Product Finder
- Vc / f
- STEEL
- VA
- Accessories
- Tech. Info

Applications – Material

M 1.1-4.1 **S** 1.1-3 **S** 2.2-4, 2.6

Drill Depth

5 x D

Tool Identification

Tool Identification													TA214524	TA514524	
Nominal Size ø d ₁ m7				Taps	Roll Form Taps	mm							Dimens. ID	EF-Drill-VA DIN6537L-HA IK-2FF ALCR-T37	EF-Drill-VA DIN6537L-HE IK-2FF ALCR-T37
inch	Fraction	Wire letter	mm			l ₁	l ₂	l ₃	l ₄	l ₅	ø d ₂ h6				
0.2165			5.500	1/4-28 UNF		82	44	35	36	1.1	6	.0550	●	★	
0.2187	7/32		5.556	1/4-28 UNJF		82	44	35	36	1.1	6	.0556	●	★	
0.2205			5.600	1/4-32 UNEF	M6	82	44	35	36	1.1	6	.0560	●	★	
0.2264			5.750		1/4-20 UNC	82	44	35	36	1.2	6	.0575	●	★	
0.2283			5.800		M6x0.5	82	44	35	36	1.2	6	.0580	●	★	
0.2323			5.900			82	44	35	36	1.2	6	.0590	●	★	
0.2344	15/64		5.954		1/4-28 UNF	82	44	35	36	1.2	6	.0595	●	★	
0.2362			6.000	M7 / Rd8x1/10		82	44	35	36	1.2	6	.0600	●	★	
0.2402			6.100	MJ7x1		91	53	43	36	1.2	8	.0610	●	★	
0.2441			6.200	M7x0.75		91	53	43	36	1.2	8	.0620	●	★	
0.2480			6.300	M7x0.5 / STI-M6		91	53	43	36	1.3	8	.0630	●	★	
0.2500	1/4	E	6.350	1/16-27 NPSF		91	53	43	36	1.3	8	.0635	●	★	
0.2520			6.400			91	53	43	36	1.3	8	.0640	●	★	
0.2559			6.500	BSW 5/16-18		91	53	43	36	1.3	8	.0650	●	★	
0.2570		F	6.528			91	53	43	36	1.3	8	.0653	●	★	
0.2598			6.600	5/16-18 UNC	M7	91	53	43	36	1.3	8	.0660	●	★	
0.2638			6.700	5/16-18 UNJC	M7x0.75	91	53	43	36	1.3	8	.0670	●	★	
0.2656	17/64		6.746			91	53	43	36	1.3	8	.0675	●	★	
0.2677			6.800	M8 / G 1/16		91	53	43	36	1.4	8	.0680	●	★	
0.2717			6.900	5/16-24 UNF		91	53	43	36	1.4	8	.0690	●	★	
0.2756			7.000	5/16-24 UNJF		91	53	43	36	1.4	8	.0700	●	★	
0.2795			7.100	MJ8x1		91	53	43	36	1.4	8	.0710	●	★	
0.2813	9/32	K	7.145			91	53	43	36	1.4	8	.0715	●	★	
0.2835			7.200	5/16-32 UNEF		91	53	43	36	1.4	8	.0720	●	★	
0.2854			7.250		5/16-18 UNC	91	53	43	36	1.4	8	.0725	●	★	
0.2874			7.300			91	53	43	36	1.5	8	.0730	●	★	
0.2913			7.400			91	53	43	36	1.5	8	.0740	●	★	
0.2933			7.450		5/16-24 UNF / M8	91	53	43	36	1.5	8	.0745	●	★	
0.2953			7.500	M8x0.5		91	53	43	36	1.5	8	.0750	●	★	
0.2969	19/64		7.541			91	53	43	36	1.5	8	.0754	●	★	
0.2992			7.600	Tr9x1.5	M8x1 / STI-M8	91	53	43	36	1.5	8	.0760	●	★	
0.3031			7.700		M8x0.75	91	53	43	36	1.5	8	.0770	●	★	
0.3071			7.800	M9		91	53	43	36	1.5	8	.0780	●	★	
0.3110			7.900	BSW 3/8-16		91	53	43	36	1.6	8	.0790	●	★	
0.3125	5/16		7.938			91	53	43	36	1.6	8	.0794	●	★	
0.3150			8.000	3/8-16 UNC		91	53	43	36	1.6	8	.0800	●	★	
0.3189			8.100	3/8-16 UNJC		103	61	49	40	1.6	10	.0810	●	★	
0.3228			8.200	M9x0.75		103	61	49	40	1.6	10	.0820	●	★	
0.3268			8.300	LK-UNC 3/8-16		103	61	49	40	1.6	10	.0830	●	★	
0.3281	21/64		8.334			103	61	49	40	1.6	10	.0833	●	★	
0.3307			8.400	STI-UNC 5/16-18		103	61	49	40	1.7	10	.0840	●	★	
0.3346			8.500	3/8-24 UNF / M10		103	61	49	40	1.7	10	.0850	●	★	
0.3386			8.600	3/8-24 UNJF	M9x1	103	61	49	40	1.7	10	.0860	●	★	
0.3425			8.700	3/8-32 UNEF	M9x0.75	103	61	49	40	1.7	10	.0870	●	★	

● = In stock
★ = Allow 7 days for delivery

- Product Finder
- v_c / f
- STEEL
- VA
- Accessories
- Tech. Info

Metric Shank

For the machining of stainless steel materials

Standard Length
Coolant Fed

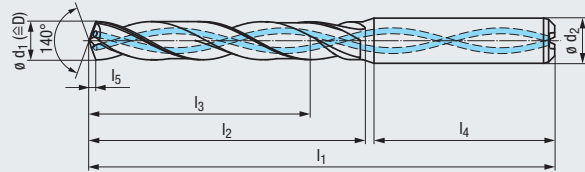

Carbide

ALCR T37

DIN 6537 L

R30

2 Flutes

2FF

140°

IT9-IT10

DIN 6535

HA
HE

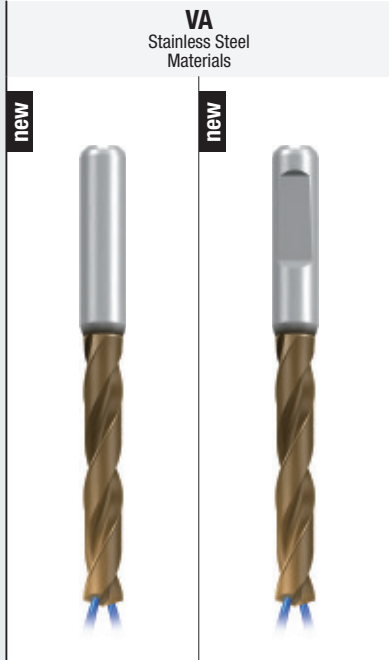

Applications – Material M 1.1-4.1 S 1.1-3 S 2.2-4, 2.6

Drill Depth 5 x D

Tool Identification											TA214524	TA514524		
Nominal Size ø d ₁ m7				Taps	Roll Form Taps	mm					Dimens. ID	EF-Drill-VA DIN6537L-HA IK-2FF ALCR-T37	EF-Drill-VA DIN6537L-HE IK-2FF ALCR-T37	
inch	Fraction	Wire letter	mm			l ₁	l ₂	l ₃	l ₄	l ₅		ø d ₂ h6		
0.3438	11/32		8.733	1/8-27 NPSC		103	61	49	40	1.7	10	.0873	●	★
0.3465			8.800	M10x1.25	3/8-16 UNC	103	61	49	40	1.7	10	.0880	●	★
0.3504			8.900	MJ10x1.25		103	61	49	40	1.8	10	.0890	●	★
0.3543			9.000	M10x1		103	61	49	40	1.8	10	.0900	●	★
0.3563			9.050		3/8-24 UNF	103	61	49	40	1.8	10	.0905	●	★
0.3583			9.100	1/8-27 NPSM		103	61	49	40	1.8	10	.0910	●	★
0.3594	23/64		9.129			103	61	49	40	1.8	10	.0913	●	★
0.3622			9.200	M10x0.75		103	61	49	40	1.8	10	.0920	●	★
0.3642			9.250		G 1/2-28	103	61	49	40	1.8	10	.0925	●	★
0.3661			9.300			103	61	49	40	1.8	10	.0930	●	★
0.3681			9.350		M10	103	61	49	40	1.8	10	.0935	●	★
0.3701			9.400	7/16-14 UNC		103	61	49	40	1.9	10	.0940	●	★
0.3740			9.500	7/16-14 UNJC	STI-M10	103	61	49	40	1.9	10	.0950	●	★
0.3750	3/8		9.525			103	61	49	40	1.9	10	.0953	●	★
0.3780			9.600		M10x1	103	61	49	40	1.9	10	.0960	●	★
0.3819			9.700	LK-UNC 7/16-14	M10x0.75	103	61	49	40	1.9	10	.0970	●	★
0.3858			9.800	STI-UNF 3/8-24		103	61	49	40	1.9	10	.0980	●	★
0.3898			9.900	7/16-20 UNF		103	61	49	40	2.0	10	.0990	●	★
0.3906	25/64		9.921			103	61	49	40	2.0	10	.0992	●	★
0.3937			10.000	7/16-20 UNJF		103	61	49	40	2.0	10	.1000	●	★
0.3976			10.100			118	71	56	45	2.0	12	.1010	●	★
0.4016			10.200	7/16-28 UNEF		118	71	56	45	2.0	12	.1020	●	★
0.4035			10.250		7/16-14 UNC	118	71	56	45	2.0	12	.1025	●	★
0.4055			10.300			118	71	56	45	2.0	12	.1030	●	★
0.4063	13/32		10.320			118	71	56	45	2.0	12	.1032	●	★
0.4134			10.500	M12x1.5		118	71	56	45	2.1	12	.1050	●	★
0.4154			10.550		7/16-20 UNF	118	71	56	45	2.1	12	.1055	●	★
0.4213			10.700	LK-M12		118	71	56	45	2.1	12	.1070	●	★
0.4219	27/64		10.716	1/2-13 UNC		118	71	56	45	2.1	12	.1072	●	★
0.4252			10.800	M12x1.25		118	71	56	45	2.1	12	.1080	●	★
0.4291			10.900	1/2-13 UNJC		118	71	56	45	2.1	12	.1090	●	★
0.4331			11.000	M12x1		118	71	56	45	2.2	12	.1100	●	★
0.4370			11.100	BSF 1/2-16		118	71	56	45	2.2	12	.1110	●	★
0.4375	7/16		11.113	LK-UNC 1/2-13		118	71	56	45	2.2	12	.1111	●	★
0.4409			11.200			118	71	56	45	2.2	12	.1120	●	★
0.4429			11.250	M12x0.75	M12	118	71	56	45	2.2	12	.1125	●	★
0.4469			11.350	Pg7	M12x1.5	118	71	56	45	2.2	12	.1135	●	★
0.4488			11.400	1/4-18 NPSC		118	71	56	45	2.2	12	.1140	●	★
0.4508			11.450		M12x1.25	118	71	56	45	2.2	12	.1145	●	★
0.4528			11.500	1/2-20 UNF		118	71	56	45	2.3	12	.1150	●	★
0.4531	29/64		11.509			118	71	56	45	2.3	12	.1151	●	★
0.4567			11.600	1/2-20 UNJF	M12x1	118	71	56	45	2.3	12	.1160	●	★
0.4606			11.700			118	71	56	45	2.3	12	.1170	●	★
0.4646			11.800	1/2-28 UNEF	1/2-13 UNC	118	71	56	45	2.3	12	.1180	●	★

Metric Shank

For the machining of stainless steel materials

Standard Length
Coolant Fed

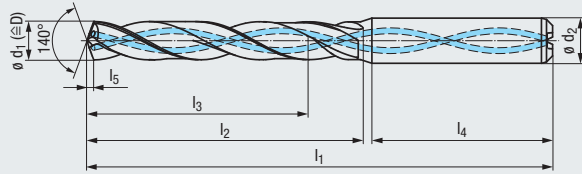

Carbide **ALCR T37**

DIN 6537 L **R30**

2 Flutes **2FF**

140° **IT9-IT10**

DIN 6535
HA HE

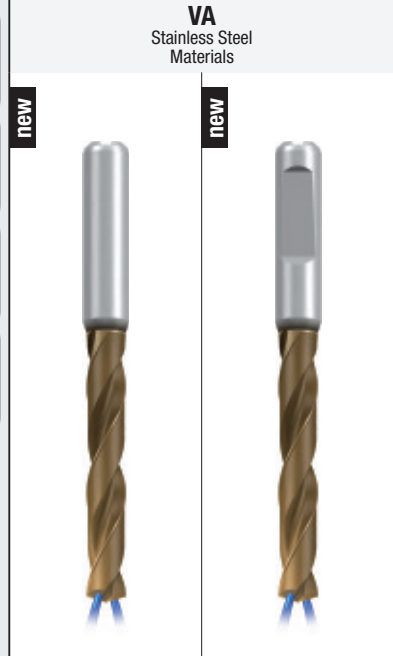

- Product Finder
- Vc / f
- STEEL
- VA
- Accessories
- Tech. Info

Applications – Material

M 1.1-4.1 **S** 1.1-3 **S** 2.2-4, 2.6

Drill Depth

5 x D

Tool Identification

Tool Identification												TA214524	TA514524	
Nominal Size ø d ₁ m7				Taps	Roll Form Taps	mm						Dimens. ID	EF-Drill-VA DIN6537L-HA IK-2FF ALCR-T37	EF-Drill-VA DIN6537L-HE IK-2FF ALCR-T37
inch	Fraction	Wire letter	mm			l ₁	l ₂	l ₃	l ₄	l ₅	ø d ₂ h6			
0.4685			11.900			118	71	56	45	2.3	12	.1190	●	★
0.4688	15/32		11.908			118	71	56	45	2.3	12	.1191	●	★
0.4724			12.000	M14		118	71	56	45	2.4	12	.1200	●	★
0.4783			12.150		1/2-20 UNF	124	77	60	45	2.4	14	.1215	●	★
0.4803			12.200	Tr 14x2		124	77	60	45	2.4	14	.1220	●	★
0.4844	31/64		12.304	9/16-12 UNC		124	77	60	45	2.4	14	.1230	●	★
0.4921			12.500	M14x1.5		124	77	60	45	2.4	14	.1250	●	★
0.4941			12.550		G1/4-19	124	77	60	45	2.5	14	.1255	●	★
0.5000	1/2		12.700	LK-UNC 9/16-12		124	77	60	45	2.5	14	.1270	●	★
0.5039			12.800	M14x1.25		124	77	60	45	2.5	14	.1280	●	★
0.5118			13.000	9/16-18 UNJF		124	77	60	45	2.5	14	.1300	●	★
0.5157			13.100	STI-UNF 1/2-20	M14	124	77	60	45	2.6	14	.1310	●	★
0.5236			13.300	9/16-24 UNEF	9/16-12 UNC	124	77	60	45	2.6	14	.1330	●	★
0.5256			13.350		M14x1.5	124	77	60	45	2.6	14	.1335	●	★
0.5295			13.450		M14x1.25	124	77	60	45	2.6	14	.1345	●	★
0.5313	17/32		13.495	5/8-11 UNC		124	77	60	45	2.6	14	.1349	●	★
0.5315			13.500			124	77	60	45	2.6	14	.1350	●	★
0.5374			13.650	5/8-11 UNJC	9/16-18 UNF	124	77	60	45	2.7	14	.1365	●	★
0.5394			13.700			124	77	60	45	2.7	14	.1370	●	★
0.5469	35/64		13.891			124	77	60	45	2.7	14	.1389	●	★
0.5512			14.000	M16 / M15x1		124	77	60	45	2.7	14	.1400	●	★
0.5551			14.100			133	83	63	48	2.8	16	.1410	●	★
0.5625	9/16		14.288			133	83	63	48	2.8	16	.1429	●	★
0.5709			14.500	5/8-18 UNF		133	83	63	48	2.8	16	.1450	●	★
0.5748			14.600	5/8-18 UNJF	M15x1	133	83	63	48	2.9	16	.1460	●	★
0.5781	37/64		14.684	3/8-18 NPSC		133	83	63	48	2.9	16	.1468	●	★
0.5827			14.800		5/8-11 UNC	133	83	63	48	2.9	16	.1480	●	★
0.5906			15.000	M16x1		133	83	63	48	2.9	16	.1500	●	★
0.5938	19/32		15.083			133	83	63	48	2.9	16	.1508	●	★
0.5945			15.100		M16	133	83	63	48	2.9	16	.1510	●	★
0.6102			15.500	M18		133	83	63	48	3.0	16	.1550	●	★
0.6142			15.600		M16x1	133	83	63	48	3.0	16	.1560	●	★
0.6250	5/8		15.875			133	83	63	48	3.1	16	.1588	●	★
0.6299			16.000	M18x2		133	83	63	48	3.1	16	.1600	●	★
0.6406	41/64		16.272			143	93	71	48	3.2	18	.1627	●	★
0.6496			16.500	STI-UNC 5/8-11		143	93	71	48	3.2	18	.1650	●	★
0.6563	21/32		16.669	3/4-10 UNC		143	93	71	48	3.2	18	.1667	●	★
0.6693			17.000	M18x1		143	93	71	48	3.3	18	.1700	●	★
0.6875	11/16		17.463			143	93	71	48	3.4	18	.1746	●	★
0.6890			17.500	3/4-16 UNF / M20		143	93	71	48	3.4	18	.1750	●	★
0.7087			18.000	M20x2 / LK-M16		143	93	71	48	3.5	18	.1800	●	★
0.7480			19.000	M20x1		153	101	77	50	3.7	20	.1900	●	★
0.7500	3/4		19.050			153	101	77	50	3.7	20	.1905	●	★
0.7874			20.000	M22x2	G1/2-14	153	101	77	50	3.9	20	.2000	●	★

● = In stock
★ = Allow 7 days for delivery

- 3 x D
- 5 x D
- 6 x D
- 8 x D
- 2-3.5 x D



- Product Finder
- v_c / f
- STEEL
- VA
- Accessories
- Tech. Info

new

STEEL
Steel & Universal Applications



Applications – Material

P 1.1-5.1	M 1.1
K 1.1-4.2	N 1.4-5

TM003324

Nominal Size ϕd_1 k8		Taps	Roll Form Taps	Size of Insert Seat	mm		Dimens. ID	EF-Drill Modular STEEL AK-2FF TIALN-T21
inch	Fraction				l_1	l_5		
0.5512				2	8	2.7	.1400	●
0.5551				2	8	2.8	.1410	●
0.5591				2	8	2.8	.1420	●
0.5625	9/16			2	8	2.8	.1429	●
0.5630				2	8	2.8	.1430	●
0.5669				2	8	2.8	.1440	●
0.5709				2	8	2.8	.1450	●
0.5748		5/8-18 UNF		2	8	2.9	.1460	●
0.5781	37/64	5/8-18 UNJF	M15x1	2	8	2.9	.1468	●
0.5787		3/8-18 NPSC		2	8	2.9	.1468	●
0.5827		STI-UNF 9/16-18	M15x0.75	2	8	2.9	.1470	●
0.5827			5/8-11 UNC	2	8	2.9	.1480	●
0.5866		STI-UNC 9/16-12		2	8	2.9	.1490	●
0.5906		M16x1		2	8	2.9	.1500	●
0.5937	19/32			2	8	2.9	.1508	●
0.5945		MJ16x1	M16	2	8	2.9	.1510	●
0.5984		M16x0.75		2	8	3.0	.1520	●
0.6024				2	8	3.0	.1530	●
0.6043			M16x1.5	2	8	3.0	.1535	●
0.6063				2	8	3.0	.1540	●
0.6094	39/64			2	8	3.0	.1548	●
0.6102		M18		2	8	3.0	.1550	●
0.6142			M16x1	2	8	3.0	.1560	●
0.6181			M16x0.75	2	8	3.1	.1570	●
0.6220		MJ18x2.5		2	8	3.1	.1580	●
0.6252	5/8			2	8	3.1	.1588	●
0.6260				2	8	3.1	.1590	●
0.6299		M18x2		3	9	3.1	.1600	●
0.6339		MJ17x1		3	9	3.1	.1610	●
0.6378				3	9	3.2	.1620	●
0.6406	41/64			3	9	3.2	.1627	●
0.6417				3	9	3.2	.1630	●
0.6457				3	9	3.2	.1640	●
0.6496		STI-UNC 5/8-11		3	9	3.2	.1650	●
0.6535		MJ18x1.5		3	9	3.2	.1660	●
0.6563	21/32	3/4-10 UNC		3	9	3.2	.1667	●
0.6575				3	9	3.3	.1670	●
0.6614				3	9	3.3	.1680	●
0.6634			M18	3	9	3.3	.1685	●
0.6654				3	9	3.3	.1690	●
0.6693		M18x1		3	9	3.3	.1700	●
0.6719	43/64			3	9	3.3	.1707	●
0.6732		MJ18x1	M18x2	3	9	3.3	.1710	●
0.6772				3	9	3.4	.1720	●
0.6811				3	9	3.4	.1730	●
0.6831			M18x1.5	3	9	3.4	.1735	●
0.6850				3	9	3.4	.1740	●
0.6870	11/16			3	9	3.4	.1745	●
0.6890		3/4-16 UNF / M20		3	9	3.4	.1750	●
0.6929			M18x1	3	9	3.4	.1760	●
0.6969				3	9	3.4	.1770	●
0.7008		MJ20x2.5		3	9	3.5	.1780	●
0.7047				3	9	3.5	.1790	●
0.7087		M20x2 / LK-M16		3	9	3.5	.1800	●
0.7126				3	9	3.5	.1810	●
0.7165				3	9	3.5	.1820	●
0.7188	23/32			3	9	3.6	.1826	●

Ordering Example: TM003324.1400

- 3 x D
- 5 x D
- 6 x D
- 8 x D
- 2-3.5 x D



Solid Carbide Cutting Head

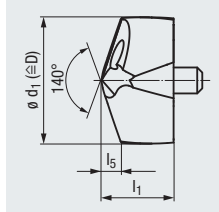

Carbide

TIALN T21

R30

2 Flutes

2FF

140°

IT9-IT11

Solid Carbide Cutting Head

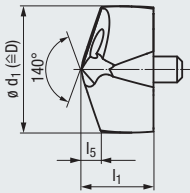

Carbide

TIALN
T21

new

R30

2 Flutes



2FF



140°



IT9-IT11

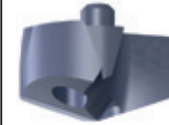

STEEL
Steel & Universal
Applications

Product
Finder

V_c / f

STEEL

VA

Accessories

Tech. Info

Applications – Material

P 1.1-5.1 M 1.1
K 1.1-4.2 N 1.4-5

Tool Identification

TM003324

Nominal Size $\varnothing d_1$ k8			Taps	Roll Form Taps	Size of Insert Seat	mm		Dimens. ID	EF-Drill Modular STEEL AK-2FF TIALN-T21
inch	Fraction	mm				l_1	l_5		
0.7205		18.30			3	9	3.6	.1830	●
0.7244		18.40			3	9	3.6	.1840	●
0.7283		18.50	M20x1.5		3	9	3.6	.1850	●
0.7323		18.60	MJ20x1.5		3	9	3.6	.1860	●
0.7344	47/64	18.65			3	9	3.6	.1865	●
0.7362		18.70			3	9	3.6	.1870	●
0.7402		18.80			3	9	3.7	.1880	●
0.7421		18.85		M20	3	9	3.7	.1885	●
0.7441		18.90			3	9	3.7	.1890	●
0.7480		19.00	M20x1		4	11	3.7	.1900	●
0.7500	3/4	19.05			4	11	3.7	.1905	●
0.7520		19.10	MJ20x1	M20x2	4	11	3.7	.1910	●
0.7559		19.20			4	11	3.7	.1920	●
0.7598		19.30			4	11	3.8	.1930	●
0.7618		19.35		M20x1.5	4	11	3.8	.1935	●
0.7638		19.40			4	11	3.8	.1940	●
0.7657	49/64	19.45			4	11	3.8	.1945	●
0.7677		19.50	STI-UNF 3/4-16		4	11	3.8	.1950	●
0.7717		19.60		M20x1	4	11	3.8	.1960	●
0.7756		19.70			4	11	3.8	.1970	●
0.7795		19.80			4	11	3.9	.1980	●
0.7815	25/32	19.85			4	11	3.9	.1985	●
0.7835		19.90			4	11	3.9	.1990	●
0.7874		20.00	M22x2	G 1/2-14	4	11	3.9	.2000	●
0.7913		20.10			4	11	3.9	.2010	●
0.7953		20.20			4	11	3.9	.2020	●
0.7969	51/64	20.24			4	11	3.9	.2024	●
0.7992		20.30			4	11	3.9	.2030	●
0.8310		20.40			4	11	4.0	.2040	●
0.8710		20.50	M22x1.5		4	11	4.0	.2050	●
0.8110		20.60	MJ22x1.5		4	11	4.0	.2060	●
0.8126	13/16	20.64			4	11	4.0	.2064	●
0.8150		20.70			4	11	4.0	.2070	●
0.8189		20.80			4	11	4.0	.2080	●
0.8209		20.85		M22	4	11	4.1	.2085	●
0.8228		20.90		7/8-9 UNC	4	11	4.1	.2090	●
0.8268		21.00	M24 / M22x1		4	11	4.1	.2100	●
0.8307		21.10	MJ22x1	M22x2	4	11	4.1	.2110	●
0.8346		21.20			4	11	4.1	.2120	●
0.8386		21.30			4	11	4.1	.2130	●
0.8406		21.35		M22x1.5	4	11	4.1	.2135	●
0.8425		21.40		7/8-14 UNF	4	11	4.2	.2140	●
0.8438	27/32	21.43			4	11	4.2	.2143	●
0.8465		21.50			4	11	4.2	.2150	●
0.8504		21.60		M22x1	4	11	4.2	.2160	●
0.8543		21.70			4	11	4.2	.2170	●
0.8583		21.80			4	11	4.2	.2180	●
0.8594	55/64	21.83			4	11	4.2	.2183	●
0.8622		21.90			4	11	4.3	.2190	●
0.8661		22.00	M24x2		5	12.5	4.3	.2200	●
0.8701		22.10			5	12.5	4.3	.2210	●
0.8740		22.20			5	12.5	4.3	.2220	●
0.8750	7/8	22.23	1-8 UNC		5	12.5	4.3	.2223	●
0.8780		22.30			5	12.5	4.3	.2230	●
0.8819		22.40			5	12.5	4.3	.2240	●
0.8858		22.50	M24x1.5		5	12.5	4.4	.2250	●

3 x D
5 x D
6 x D
8 x D
2-3.5 x D



● = In stock
★ = Allow 7 days for delivery

- Product Finder
- v_c / f
- STEEL
- VA
- Accessories
- Tech. Info

STEEL
Steel & Universal Applications

new



Solid Carbide Cutting Head

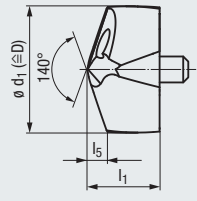

Carbide

TIALN T21

R30

2 Flutes

2FF

140°

IT9-IT11

Applications – Material

P 1.1-5.1	M 1.1
K 1.1-4.2	N 1.4-5

Tool Identification									TM003324
Nominal Size ϕd_1 k8			Taps	Roll Form Taps	Size of Insert Seat	mm		Dimens. ID	EF-Drill Modular STEEL AK-2FF TIALN-T21
inch	Fraction	mm				l_1	l_5		
0.8898		22.60	MJ24x1.5	M24	5	12.5	4.4	.2260	●
0.8917		22.65			5	12.5	4.4	.2265	●
0.8937		22.70			5	12.5	4.4	.2270	●
0.8976		22.80			5	12.5	4.4	.2280	●
0.9016		22.90			5	12.5	4.4	.2290	●
0.9055		23.00	M24x1		5	12.5	4.5	.2300	●
0.9063	29/32	23.02			5	12.5	4.5	.2302	●
0.9094		23.10		M24x2	5	12.5	4.5	.2310	●
0.9134		23.20			5	12.5	4.5	.2320	●
0.9173		23.30			5	12.5	4.5	.2330	●
0.9193		23.35		M24x1.5	5	12.5	4.5	.2335	●
0.9213		23.40			5	12.5	4.5	.2340	●
0.9219	59/64	23.42	1-12 UNF		5	12.5	4.5	.2342	●
0.9252		23.50	M25x1.5		5	12.5	4.6	.2350	●
0.9291		23.60	MJ25x1.5	M24x1	5	12.5	4.6	.2360	●
0.9331		23.70			5	12.5	4.6	.2370	●
0.9370		23.80			5	12.5	4.6	.2380	●
0.9375	15/16	23.81			5	12.5	4.6	.2381	●
0.9409		23.90		1-8 UNC	5	12.5	4.6	.2390	●
0.9449		24.00	M27		5	12.5	4.7	.2400	●
0.9488		24.10	MJ25x1		5	12.5	4.7	.2410	●
0.9528		24.20			5	12.5	4.7	.2420	●
0.9567		24.30			5	12.5	4.7	.2430	●
0.9606		24.40			5	12.5	4.7	.2440	●
0.9646		24.50	M26x1.5 / G3/4		5	12.5	4.8	.2450	●
0.9685		24.60	MJ26x1.5		5	12.5	4.8	.2460	●
0.9688	31/32	24.61			5	12.5	4.8	.2461	●
0.9724		24.70			5	12.5	4.8	.2470	●
0.9764		24.80			5	12.5	4.8	.2480	●
0.9803		24.90			5	12.5	4.8	.2490	●
0.9843		25.00	1 1/8-7 UNC		5	12.5	4.8	.2500	●
0.9882		25.10			5	12.5	4.9	.2510	●
0.9921		25.20			5	12.5	4.9	.2520	●
0.9961		25.30			5	12.5	4.9	.2530	●
1.0000		25.40	1 1/8-8 UN		5	12.5	4.9	.2540	●
1.0039		25.50	M27x1.5		5	12.5	4.9	.2550	●
1.0079		25.60	MJ27x1.5	M27	5	12.5	5.0	.2560	●
1.0098		25.65			5	12.5	5.0	.2565	●
1.0118		25.70			5	12.5	5.0	.2570	●
1.0157		25.80			5	12.5	5.0	.2580	●
1.0197		25.90			5	12.5	5.0	.2590	●
1.0236		26.00	M27x1 / M28x2		6	15	5.0	.2600	●
1.0276		26.10		M27x2	6	15	5.1	.2610	●
1.0315		26.20			6	15	5.1	.2620	●
1.0354		26.30			6	15	5.1	.2630	●
1.0394		26.40			6	15	5.1	.2640	●
1.0433		26.50	1 1/8-12 UNF		6	15	5.1	.2650	●
1.0469	1 3/64	26.59			6	15	5.2	.2659	●
1.0472		26.60	MJ28x1.5	M27x1	6	15	5.2	.2660	●
1.0512		26.70			6	15	5.2	.2670	●
1.0551		26.80			6	15	5.2	.2680	●
1.0591		26.90			6	15	5.2	.2690	●
1.0626	1 1/16	26.99			6	15	5.2	.2699	●
1.0630		27.00	M30x3		6	15	5.2	.2700	●
1.0669		27.10	MJ28x1		6	15	5.3	.2710	●
1.0709		27.20			6	15	5.3	.2720	●

- 3 x D
- 5 x D
- 6 x D
- 8 x D
- 2-3.5 x D



Solid Carbide Cutting Head

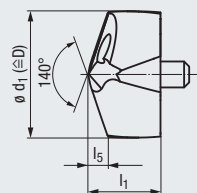

Carbide

TIALN
T21

R30

2 Flutes

2FF

140°

IT9-IT11

new

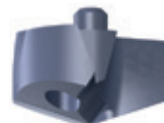

STEEL
Steel & Universal
Applications

Product
Finder

V_c / f

STEEL

VA

Accessories

Tech. Info

Applications – Material

P 1.1-5.1 M 1.1
K 1.1-4.2 N 1.4-5

Tool Identification

TM003324

Nominal Size $\varnothing d_1$ k8			Taps	Roll Form Taps	Size of Insert Seat	mm		Dimens. ID	EF-Drill Modular STEEL AK-2FF TIALN-T21
inch	Fraction	mm				l ₁	l ₅		
1.0748		27.30			6	15	5.3	.2730	●
1.0787		27.40			6	15	5.3	.2740	●
1.0827		27.50			6	15	5.3	.2750	●
1.0866		27.60			6	15	5.3	.2760	●
1.0906		27.70			6	15	5.4	.2770	●
1.0937	1 3/32	27.78			6	15	5.4	.2778	●
1.0945		27.80			6	15	5.4	.2780	●
1.0984		27.90			6	15	5.4	.2790	●
1.1024		28.00	M30x2		6	15	5.4	.2800	●
1.1063		28.10			6	15	5.4	.2810	●
1.1102		28.20			6	15	5.5	.2820	●
1.1142		28.30			6	15	5.5	.2830	●
1.1181		28.40			6	15	5.5	.2840	●
1.1220		28.50	M30x1.5		6	15	5.5	.2850	●
1.1252	1 1/8	28.58			6	15	5.5	.2858	●
1.1260		28.60	MJ30x1.5	M30x3	6	15	5.5	.2860	●
1.1299		28.70			6	15	5.6	.2870	●
1.1339		28.80			6	15	5.6	.2880	●
1.1378		28.90			6	15	5.6	.2890	●
1.1417		29.00	M30x1		6	15	5.6	.2900	●
1.1457		29.10	MJ30x1	M30x2	6	15	5.6	.2910	●
1.1496		29.20			6	15	5.7	.2920	●
1.1535		29.30			6	15	5.7	.2930	●
1.1555		29.35		M30x1.5	6	15	5.7	.2935	●
1.1563	1 5/32	29.37			6	15	5.7	.2937	●
1.1575		29.40			6	15	5.7	.2940	●
1.1614		29.50	M33		6	15	5.7	.2950	●
1.1654		29.60		M30x1	6	15	5.7	.2960	●
1.1693		29.70			6	15	5.8	.2970	●
1.1732		29.80			6	15	5.8	.2980	●
1.1772		29.90			6	15	5.8	.2990	●
1.1811		30.00	M32x2 / M33x3		7	17	5.8	.3000	●
1.1850		30.10			7	17	5.8	.3010	●
1.1874	1 3/16	30.16			7	17	5.8	.3016	●
1.1890		30.20			7	17	5.8	.3020	●
1.1929		30.30			7	17	5.9	.3030	●
1.1969		30.40			7	17	5.9	.3040	●
1.2008		30.50	M32x1.5		7	17	5.9	.3050	●
1.2047		30.60	MJ32x1.5		7	17	5.9	.3060	●
1.2087		30.70			7	17	5.9	.3070	●
1.2126		30.80			7	17	6.0	.3080	●
1.2165		30.90			7	17	6.0	.3090	●
1.2189	1 7/32	30.96			7	17	6.0	.3096	●
1.2205		31.00	1 3/8-6 UNC		7	17	6.0	.3100	●
1.2244		31.10	MJ32x1		7	17	6.0	.3110	●
1.2283		31.20			7	17	6.0	.3120	●
1.2323		31.30			7	17	6.1	.3130	●
1.2362		31.40			7	17	6.1	.3140	●
1.2402		31.50	M33x1.5		7	17	6.1	.3150	●
1.2441		31.60		M33x3	7	17	6.1	.3160	●
1.2480		31.70			7	17	6.1	.3170	●
1.2500	1 1/4	31.75	1 3/8-8 UN		7	17	6.1	.3175	●
1.2520		31.80			7	17	6.2	.3180	●
1.2559		31.90			7	17	6.2	.3190	●
1.2598		32.00	M36		7	17	6.2	.3200	●

3 x D
5 x D
6 x D
8 x D
2-3.5 x D



● = In stock
★ = Allow 7 days for delivery

- Product Finder
- v_c / f
- STEEL
- VA
- Accessories
- Tech. Info

Metric Shank

R30



new

new



Tool Body, Stub Length
Coolant Fed

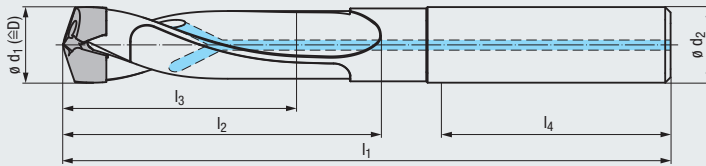

Drill Depth

3 x D

Tool Identification

Nominal Size ϕd_1					mm						Dimens. ID	TM200000	TM500000
inch		mm		Size of Insert Seat	l_1	l_2	l_3	l_4	ϕd_2 h6	EF-Drill Modular DIN 6535 HA 3 x D		EF-Drill Modular DIN 6535 HE 3 x D	
min.	max.	min.	max.							●		★	
0.5512	0.5705	14.00	14.49	2	124	65	43	48	16	.1400	●	★	
0.5709	0.5902	14.50	14.99	2	125	67	45	48	16	.1450	●	★	
0.5906	0.6295	15.00	15.99	2	129	72	48	48	16	.1500	●	★	
0.6299	0.6689	16.00	16.99	3	136	76	51	48	18	.1600	●	★	
0.6693	0.7083	17.00	17.99	3	139	81	54	48	18	.1700	●	★	
0.7087	0.7476	18.00	18.99	3	147	85	57	50	20	.1800	●	★	
0.7480	0.7870	19.00	19.99	4	150	90	60	50	20	.1900	●	★	
0.7874	0.8264	20.00	20.99	4	165	94	63	56	25	.2000	●	★	
0.8268	0.8657	21.00	21.99	4	169	99	66	56	25	.2100	●	★	
0.8661	0.9051	22.00	22.99	5	173	103	69	56	25	.2200	●	★	
0.9055	0.9445	23.00	23.99	5	177	108	72	56	25	.2300	●	★	
0.9449	0.9839	24.00	24.99	5	181	112	75	56	25	.2400	●	★	
0.9843	1.0232	25.00	25.99	5	194	117	78	60	32	.2500	●	★	
1.0236	1.0626	26.00	26.99	6	199	121	81	60	32	.2600	●	★	
1.0630	1.1020	27.00	27.99	6	202	126	84	60	32	.2700	●	★	
1.1024	1.1413	28.00	28.99	6	207	130	87	60	32	.2800	●	★	
1.1417	1.1807	29.00	29.99	6	210	135	90	60	32	.2900	●	★	
1.1811	1.2201	30.00	30.99	7	215	139	93	60	32	.3000	●	★	
1.2205	1.2594	31.00	31.99	7	218	144	96	60	32	.3100	●	★	
1.2598	1.2988	32.00	32.99	7	223	148	99	60	32	.3200	●	★	

Delivery: without solid carbide cutting head, with Torx screws

Solid carbide cutting heads, see page 406 - 409

Screwdriver



Clamping Screw



Size of Insert Seat	Size	Blade Diameter	Article no.	
2	Torx T7	2.5	TM919099	●
3	Torx T8	3.5	TM919199	●
4	Torx T8	3.5	TM919199	●
5	Torx T9	4	TM919299	●
6	Torx T15	4	TM919399	●
7	Torx T15	4	TM919399	●

Size of Insert Seat	Size	M_d max.	Article no.	
2	M2.2 x 6 x Torx T7	0.60 Nm	TM909090.0600	●
3	M2.5 x 6.5 x Torx T8	0.88 Nm	TM909191.0650	●
4	M3 x 7.5 x Torx T8	1.53 Nm	TM909192.0750	●
5	M3.5 x 8.5 x Torx T9	2.44 Nm	TM909293.0850	●
6	M4 x 10 x Torx T15	3.66 Nm	TM909394.1000	●
7	M4.5 x 11 x Torx T15	5.22 Nm	TM909395.1100	●

Metric Shank

R30

2 Flutes **2FF**

DIN 6535 **IT10-IT11**

HA HE

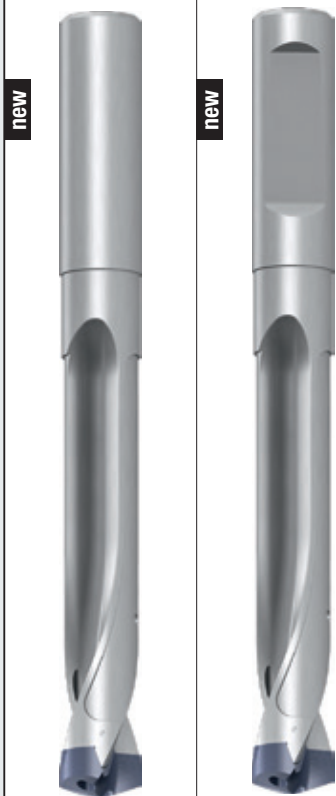

- Product Finder
- v_c / f
- STEEL
- VA
- Accessories
- Tech. Info

**Tool Body, Standard Length
Coolant Fed**

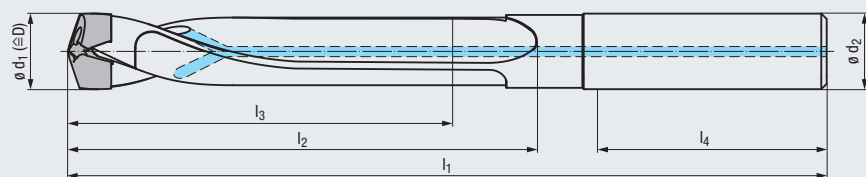

Drill Depth

5 x D

Tool Identification

Nominal Size $\varnothing d_1$				Size of Insert Seat	mm				$\varnothing d_2$ h6	Dimens. ID	TM210000	TM510000
inch min.	inch max.	mm min.	mm max.		l_1	l_2	l_3	l_4			EF-Drill Modular DIN 6535 HA 5 x D	EF-Drill Modular DIN 6535 HE 5 x D
0.5512	0.5705	14.00	14.49	2	153	94	72	48	16	.1400	●	★
0.5709	0.5902	14.50	14.99	2	155	97	75	48	16	.1450	●	★
0.5906	0.6295	15.00	15.99	2	161	104	80	48	16	.1500	●	★
0.6299	0.6689	16.00	16.99	3	170	110	85	48	18	.1600	●	★
0.6693	0.7083	17.00	17.99	3	175	117	90	48	18	.1700	●	★
0.7087	0.7476	18.00	18.99	3	185	123	95	50	20	.1800	●	★
0.7480	0.7870	19.00	19.99	4	190	130	100	50	20	.1900	●	★
0.7874	0.8264	20.00	20.99	4	207	136	105	56	25	.2000	●	★
0.8268	0.8657	21.00	21.99	4	213	143	110	56	25	.2100	●	★
0.8661	0.9051	22.00	22.99	5	219	149	115	56	25	.2200	●	★
0.9055	0.9445	23.00	23.99	5	225	156	120	56	25	.2300	●	★
0.9449	0.9839	24.00	24.99	5	231	162	125	56	25	.2400	●	★
0.9843	1.0232	25.00	25.99	5	246	169	130	60	32	.2500	●	★
1.0236	1.0626	26.00	26.99	6	253	175	135	60	32	.2600	●	★
1.0630	1.1020	27.00	27.99	6	258	182	140	60	32	.2700	●	★
1.1024	1.1413	28.00	28.99	6	265	188	145	60	32	.2800	●	★
1.1417	1.1807	29.00	29.99	6	270	195	150	60	32	.2900	●	★
1.1811	1.2201	30.00	30.99	7	277	201	155	60	32	.3000	●	★
1.2205	1.2594	31.00	31.99	7	282	208	160	60	32	.3100	●	★
1.2598	1.2988	32.00	32.99	7	289	214	165	60	32	.3200	●	★

Delivery: without solid carbide cutting head, with Torx screws

Solid carbide cutting heads, see page 406 - 409

Screwdriver



Clamping Screw



Size of Insert Seat	Size	Blade Diameter	Article no.	
2	Torx T7	2.5	TM919099	●
3	Torx T8	3.5	TM919199	●
4	Torx T8	3.5	TM919199	●
5	Torx T9	4	TM919299	●
6	Torx T15	4	TM919399	●
7	Torx T15	4	TM919399	●

Size of Insert Seat	Size	M_d max.	Article no.	
2	M2.2 x 6 x Torx T7	0.60 Nm	TM909090.0600	●
3	M2.5 x 6.5 x Torx T8	0.88 Nm	TM909191.0650	●
4	M3 x 7.5 x Torx T8	1.53 Nm	TM909192.0750	●
5	M3.5 x 8.5 x Torx T9	2.44 Nm	TM909293.0850	●
6	M4 x 10 x Torx T15	3.66 Nm	TM909394.1000	●
7	M4.5 x 11 x Torx T15	5.22 Nm	TM909395.1100	●

● = In stock
★ = Allow 7 days for delivery

- Product Finder
- v_c / f
- STEEL
- VA
- Accessories
- Tech. Info

Metric Shank

Variable step length in millimeter steps

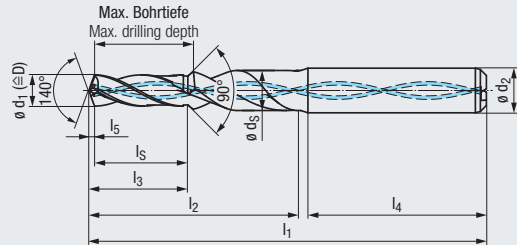

Carbide

TIALN T14

STEEL
Steel & Universal
Applications

new

≈ DIN
6537 K

2 Flutes



4FF



140°



IT8-IT10



DIN 6535

HA



Applications – Material

P	1.1-5.1	M	1.1
K	1.1-4.2	N	1.1-5
N	2.1-8	H	1.1-2

Drill Depth

2 - 3.5 x D

Tool Identification

Nominal Size $\varnothing d_1$ m7	Taps	Roll Form Taps	mm										Dimens.- Ident
			$\varnothing d_3$	l_1	l_2	l_3		l_4	l_5	l_s		$\varnothing d_2$ h6	
inch	mm					2 x D min.	3.5 x D max.			2 x D min.	3.5 x D max.		
0.1102	2.80	#6-32UNC	M3	4	57	17	6.6 - 10.6	36	0.6	6 - 10	6	.028006 - .028010	●
0.1142	2.90	#6-32UNJC	#5-40 UNC	4	57	18	6.6 - 10.6	36	0.6	6 - 10	6	.029006 - .029010	●
0.1280	3.25		M3.5	5	62	24	7.7 - 11.7	36	0.6	7 - 11	6	.032507 - .032511	●
0.1299	3.30	M4		5	62	24	7.7 - 12.7	36	0.7	7 - 12	6	.033007 - .033012	●
0.1457	3.70	M4.5	M4	5	62	24	7.8 - 13.8	36	0.7	7 - 13	6	.037007 - .037013	●
0.1654	4.20	M5 / STI-M4	M4.5	6	66	29	8.9 - 15.9	36	0.8	8 - 15	6	.042008 - .042015	●
0.1831	4.65	#12-24 UNJC	M5	6	66	29	9.9 - 16.9	36	0.9	9 - 16	6	.046509 - .046516	●
0.1969	5.00	M6	#12-24 UNC	7	79	40	11.0 - 19.0	36	1.0	10 - 18	8	.050010 - .050018	●
0.2205	5.60	1/4-32 UNEF	M6	7	79	40	12.1 - 21.1	36	1.1	11 - 20	8	.056011 - .056020	●
0.2362	6.00	M7 / Rd8x1/10		8	79	42	13.2 - 22.2	36	1.1	12 - 21	8	.060012 - .060021	●
0.2598	6.60	5/16-18 UNC	M7	8	89	45	14.3 - 24.3	40	1.3	13 - 23	10	.066013 - .066023	●
0.2677	6.80	M8 / G 1/16		9	89	46	15.4 - 25.4	40	1.3	14 - 24	10	.068014 - .068024	●
0.2756	7.00	5/16-24 UNJF		9	89	46	15.4 - 26.4	40	1.3	14 - 25	10	.070014 - .070025	●
0.2933	7.45		5/16-24 UNF / M8	9	89	46	16.5 - 27.5	40	1.4	15 - 26	10	.074515 - .074526	●
0.2992	7.60	Tr9x1.5	M8x1 / STI-M8	9	89	46	16.5 - 28.5	40	1.4	15 - 27	10	.076015 - .076027	●
0.3071	7.80	M9		10	89	48	17.5 - 28.5	40	1.5	16 - 27	10	.078016 - .078027	●
0.3327	8.45		M9	12	102	56	18.7 - 31.7	45	1.6	17 - 30	12	.084517 - .084530	●
0.3346	8.50	3/8-24 UNF / M10		12	102	56	18.7 - 31.7	45	1.6	17 - 30	12	.085017 - .085030	●
0.3543	9.00	M10x1		12	102	56	19.8 - 33.8	45	1.7	18 - 32	12	.090018 - .090032	●
0.3681	9.35		M10	12	102	56	20.8 - 34.8	45	1.8	19 - 33	12	.093519 - .093533	●
0.3740	9.50	7/16-14 UNJC	STI-M10	12	102	56	20.9 - 34.9	45	1.8	19 - 33	12	.095019 - .095033	●
0.3780	9.60		M10x1	12	102	56	20.9 - 35.9	45	1.8	19 - 34	12	.096019 - .096034	●
0.4016	10.20	7/16-28 UNEF		14	107	61	22.0 - 38.0	45	1.9	20 - 36	14	.102020 - .102036	●
0.4075	10.35			14	107	61	23.0 - 38.0	45	1.9	21 - 36	14	.103521 - .103536	●
0.4134	10.50	M12x1.5		14	107	61	23.1 - 39.1	45	2.0	21 - 37	14	.105021 - .105037	●
0.4429	11.25	M12x0.75	M12	14	107	61	25.2 - 41.2	45	2.1	23 - 39	14	.112523 - .112539	●
0.4469	11.35	Pg7	M12x1.5	14	107	61	25.2 - 42.2	45	2.1	23 - 40	14	.113523 - .113540	●
0.4724	12.00	M14		16	115	66	26.4 - 44.4	48	2.2	24 - 42	16	.120024 - .120042	●
0.4921	12.50	M14x1.5		16	115	66	27.4 - 46.4	48	2.3	25 - 44	16	.125025 - .125044	●
0.5157	13.10	STI-UNF 1/2-20	M14	16	115	66	28.6 - 48.6	48	2.4	26 - 46	16	.131026 - .131046	●
0.5256	13.35		M14x1.5	16	115	66	29.6 - 49.6	48	2.5	27 - 47	16	.133527 - .133547	●
0.5512	14.00	M16 / M15x1		18	123	74	30.7 - 51.7	48	2.6	28 - 49	18	.140028 - .140049	●
0.5709	14.50	5/8-18 UNF		18	123	74	31.8 - 53.8	48	2.7	29 - 51	18	.145029 - .145051	●
0.5945	15.10		M16	18	123	74	32.9 - 55.9	48	2.8	30 - 53	18	.151030 - .151053	●
0.6043	15.35			18	123	74	34.0 - 57.0	48	2.8	31 - 54	18	.153531 - .153554	●
0.6102	15.50	M18		20	131	80	34.0 - 57.0	50	2.9	31 - 54	20	.155031 - .155054	●

Ordering Example: **TG203344.0280 07**

Visit EMUGE's EF-Drill C quick finder application at
www.emuge.com/products/drills/ef-c-drills
for a complete listing of stocked tap drill sizes.

Drill diameter $d_1 = 2.80$ mm

Step length $l_s = 7$ mm



Product
Finder

v_c / f

STEEL

VA

Accessories

Tech. Info

- 3 x D
- 5 x D
- 6 x D
- 8 x D
- 2-3.5 x D



● = In stock
★ = Allow 7 days for delivery

- Product Finder
- v_c / f
- STEEL
- VA
- Accessories
- Tech. Info

Inch / Metric Shank

Pre-drill for 135° or 140° point carbide drill

Carbide

TIALN
T14

2 Flutes



new

≈ ASME
B94.19

DIN 6535

HA

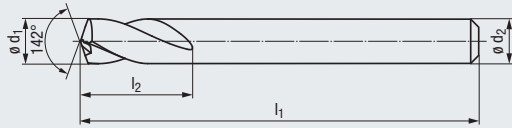

Applications – Material

P	1.1-5.1	M	1.1-3.1	K	1.1-4.2
N	1.1-1.5	N	2.1-4.2	N	5.1
S	1.1, 2.2	S	2.4, 2.6	H	1.1

Point Angle

142°

Tool Identification

EFUT3300

Inch	inch	Dimens. ID		
ϕd_1	ϕd_2 h6	l_1	l_2	
1/8	1/8	2.00	0.75	.0317
1/4	1/4	2.50	0.75	.0635
3/8	3/8	3.00	1.00	.0952
1/2	1/2	3.00	1.00	.1270
5/8	5/8	4.00	1.25	.1587
3/4	3/4	4.00	1.75	.1905

Tool Identification

EFUT3300

Metric	mm	inch		
ϕd_1 mm	ϕd_2 h6	l_1	l_2	Dimens. ID
3	3	2.00	0.50	.0300
4	4	2.25	0.75	.0400
5	5	2.25	0.75	.0500
6	6	2.25	0.75	.0600
8	8	2.75	1.00	.0800
10	10	2.88	1.00	.1000
12	12	2.92	1.00	.1200
16	16	4.00	1.00	.1600



Inch / Metric Shank

EMUGE spot / chamfer drills are designed with a double angle that allows easy drill starts and perfect 90° or 120° degree chamfer angles. Extensive testing has shown superior cutting action at the tip angle with a 142° angle which is well suited for a wide range of materials. This double angle eliminates tip breakage that is sometimes associated with 90° or 120° spot drills.

- Double tip angle with short chisel edge reduces axial force requirement
- 142° entry point angle creates better chip flow
- Secondary 90° or 120° angle creates desired chamfer

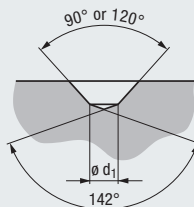
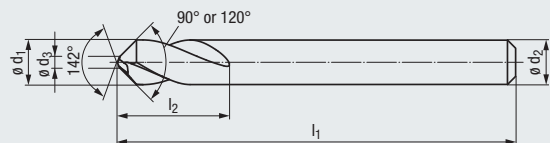

Carbide

2 Flutes



≈ ASME B94.19

DIN 6535

HA

new

new



Applications – Material

P	1.1-3.1	M	1.1-2.1	K	1.1-3.1
K	4.1-4.2	N	1.1-1.5	N	2.1-2.6
N	3.1-4.2	S	1.1	S	2.2

Double Angle

90° / 142° **120° / 142°**

Tool Identification						EFUT3100	EFUT3200	
Inch	inch					Dimens. ID		
ϕd_1 inch	ϕd_3	ϕd_2	l_1	l_2				
1/8	0.034	1/8	2.00	0.75	.0317	●		
1/4	0.068	1/4	2.50	0.75	.0635	●		
3/8	0.101	3/8	3.00	1.00	.0952	●		
1/2	0.135	1/2	3.00	1.00	.1270	●		
5/8	0.169	5/8	4.00	1.25	.1587	●		
3/4	0.203	3/4	4.00	1.75	.1905	●		
1/8	0.029	1/8	2.00	0.75	.0317		●	
1/4	0.059	1/4	2.50	0.75	.0635		●	
3/8	0.089	3/8	3.00	1.00	.0952		●	
1/2	0.118	1/2	3.00	1.00	.1270		●	
5/8	0.148	5/8	4.00	1.25	.1587		●	
3/4	0.177	3/4	4.00	1.75	.1905		●	

Tool Identification						EFUT3100	EFUT3200
Metric	mm		inch		Dimens. ID		
ϕd_1 mm	ϕd_3	ϕd_2	l_1	l_2			
3	0.81	3	2.00	0.50	.0300	●	
4	1.08	4	2.25	0.75	.0400	●	
5	1.35	5	2.25	0.75	.0500	●	
6	1.62	6	2.25	0.75	.0600	●	
8	2.16	8	2.75	1.00	.0800	●	
10	2.70	10	2.88	1.00	.1000	●	
12	3.25	12	2.92	1.00	.1200	●	
16	4.33	16	4.00	1.00	.1600	●	
3	0.71	3	2.00	0.50	.0300		●
4	0.95	4	2.25	0.75	.0400		●
5	1.18	5	2.25	0.75	.0500		●
6	1.42	6	2.25	0.75	.0600		●
8	1.89	8	2.75	1.00	.0800		●
10	2.36	10	2.88	1.00	.1000		●
12	2.84	12	2.92	1.00	.1200		●
16	3.78	16	4.00	1.00	.1600		●

● = In stock
★ = Allow 7 days for delivery

- Product Finder
- v_c / f
- STEEL
- VA
- Accessories
- Tech. Info

- 3 x D
- 5 x D
- 6 x D
- 8 x D
- 2-3.5 x D



- Product Finder
- v_c / f
- STEEL
- VA
- Accessories
- Tech. Info

Inch Shank

- Multi-functional tool
- With 4 flutes
- Taper angle 60° or 90°

Carbide

TIALN

≈ ASME
B94.19

new

new

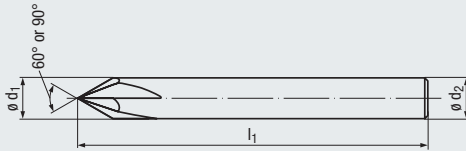

Applications – Material

P 1.1-5.1 M 1.1-3.1 K 1.1-4.2
N 1.2-4.3 N 5.1-5.3 S 1.1-2.2

Point Angle

60°

90°

Tool Identification

1715A

inch							
ϕd_1	ϕd_2 h6	l_1	Flutes	Dimens. ID			
1/8	1/8	2.0	4	.060125	•		
1/4	1/4	2.5	4	.060250	•		
3/8	3/8	3.0	4	.060375	•		
1/2	1/2	3.0	4	.060500	•		
5/8	5/8	4.0	4	.060625	•		
1/8	1/8	2.0	4	.090125		•	
1/4	1/4	2.5	4	.090250		•	
3/8	3/8	3.0	4	.090375		•	
1/2	1/2	3.0	4	.090500		•	
5/8	5/8	4.0	4	.090625		•	



Metric Shank

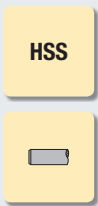

- Circumference radially and axially relieved
- Fully ground flutes
- Geometry for countersinks without chatter marks
- For deburring and counterboring drilled holes and tap holes
- Countersink for screw heads

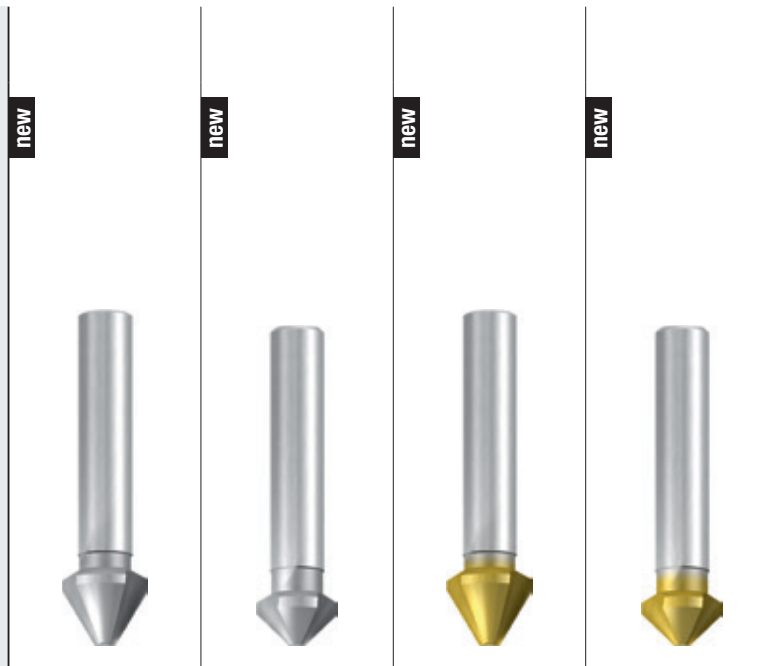
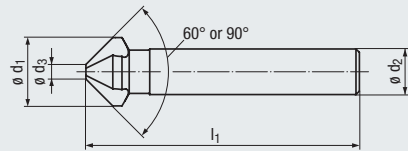

- Product Finder
- v_c / f
- STEEL
- VA
- Accessories
- Tech. Info

Coating						TIN			
Applications – Material						P 1.1-3.1 M 1.1-2.1 K 1.1-3.1		P 1.1-4.1 M 1.1-2.1 K 1.1-3.1	
						K 4.1-4.2 N 1.1-1.5 N 2.1-2.6		K 4.1-4.2 N 1.1-1.5 N 2.1-2.6	
						N 3.1-4.2 S 1.1		N 3.1-4.2 S 1.1	
Chamfer Angle						60°		90°	
Tool Identification						7550		7560	
mm									
$\varnothing d_1$	$\varnothing d_3$	l_1	$\varnothing d_2$ h9	Flutes	Dimens. ID				
6.3	1.6	45	5	3	.060063	●		●	
8	2	50	6	3	.06008	●		●	
12.5	3.2	56	8	3	.060125	●		●	
16	4	63	10	3	.06016	●		●	
20	5	67	10	3	.06020	●		●	
25	6.3	71	10	3	.06025	●		●	
6	1.5	45	5	3	.09006	●		●	
8	2	50	6	3	.09008	●		●	
12.4	2.8	56	8	3	.090124	●		●	
15	3.2	60	10	3	.09015	●		●	
25	3.8	67	10	3	.09025	●		●	

- 3 x D
- 5 x D
- 6 x D
- 8 x D
- 2-3.5 x D



● = In stock
★ = Allow 7 days for delivery

- Product Finder
- v_c / f
- STEEL
- VA
- Accessories
- Tech. Info



- 3 x D
- 5 x D
- 6 x D
- 8 x D
- 2-3.5 x D

FRANKEN Advanced Milling Technology

Complete milling solutions from EMUGE.
Visit www.emuge.com for additional information.



Technical Information

		Page
5.1	Regrinding and recoating service	420
5.2	Typical chip forms	421
5.3	Tool clamping	421
5.4	Differences in tool clamping with lateral driving flat and inclined clamping flat	421
5.5	Workpiece clamping	422
5.6	Coolant supply	423
5.7	Point angle	423
5.8	Influence of the point angle	424
5.9	Reduce feed on angled entry / exit surfaces	424
5.10	Proper edge preparation (honing)	424
5.11	Technical information EF-Drill Micro	425
5.12	Technical information EF-Drill Modular	426
5.13	Problems, possible causes and solutions in drilling	427 - 428

Product
Finder v_c / f

STEEL

VA

Accessories

Tech. Info

3 x D

5 x D

6 x D

8 x D

2-3.5 x D



5.1 Regrinding and recoating service

Regrinding and recoating form an essential contribution to the economically efficient use of drilling tools.

The EMUGE regrinding and recoating service guarantees the restoration of the original geometry and the original coating of the tool.

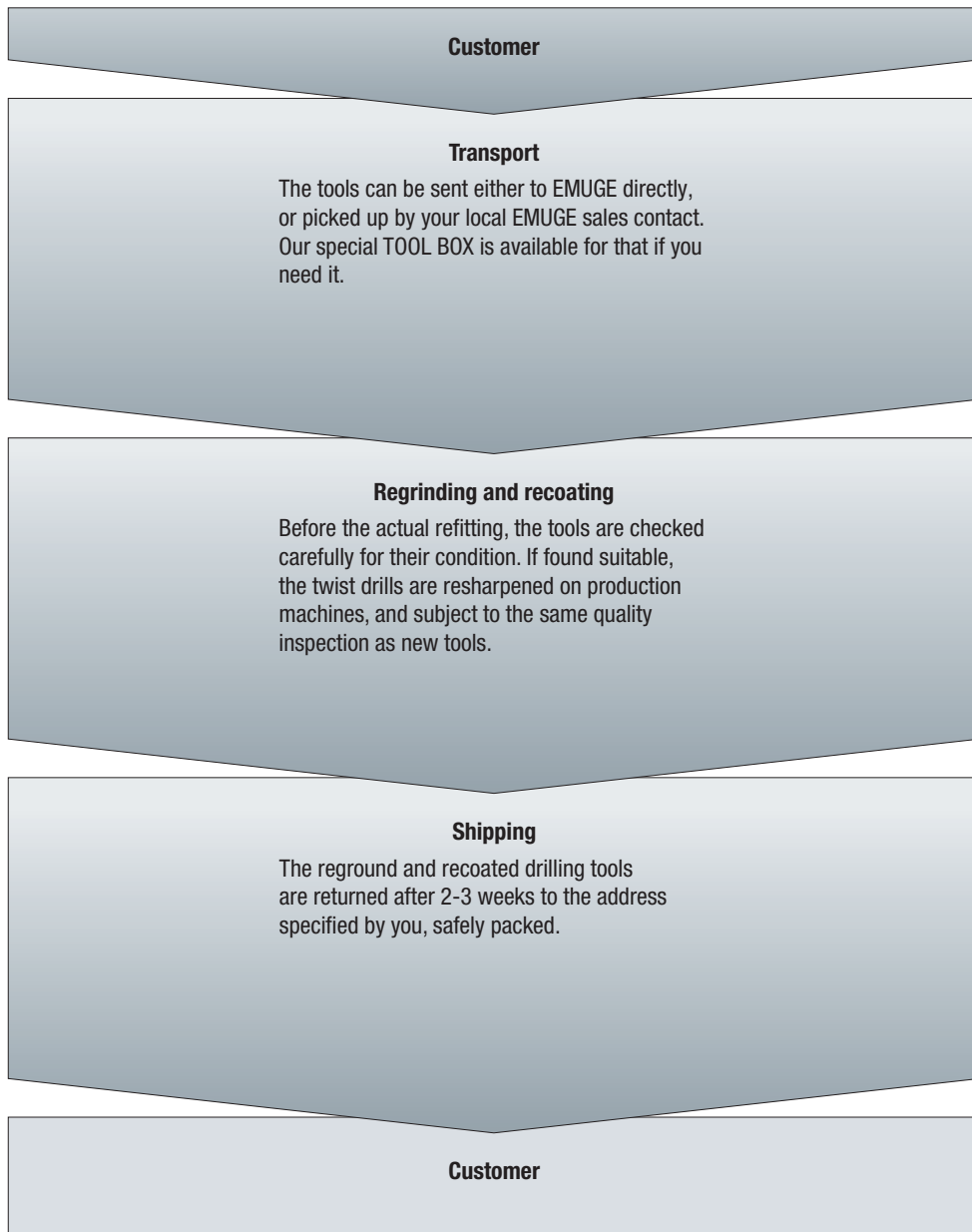
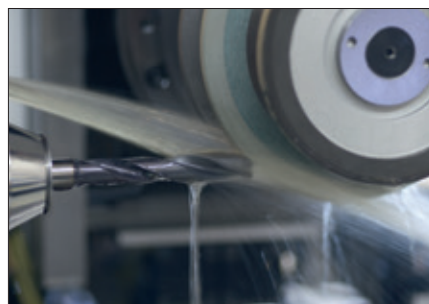

3 x D

5 x D

6 x D

8 x D

2-3.5 x D



5.2 Typical chip forms

**Start-of-drilling chip**

This chip type is produced in the start of the drilling process, before the cutting corners are engaged.

**Chamfer chip**

This chip type is created in the production of the chamfer.

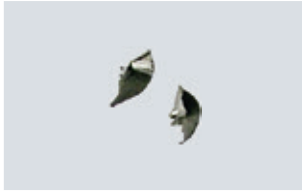
**Optimal drilling chip**

This chip type is created when the cutting data are chosen to perfection.

**Step-drill chip**

The length of this chip type can be controlled by means of dwell times in long-chipping material.

**Drill-through chip**

Note: There is need for increased space between workpiece and tool holder.

**Hooked up chips**

These chips are produced especially in long-chipping materials, or when cutting data are not optimally chosen. Single entangled chips are not such a big issue, but when the entanglement of the chips becomes permanent it will soon lead to chip clogging, and with it to drill breakage.

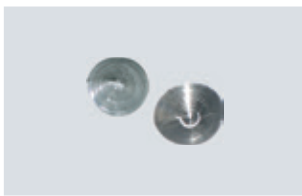
**Drill-through slug**

Note: There is need for increased space for chips and lid in drilling through!

**Ribbon chip / flow chip**

Note: When you observe this chip type, the drill already has serious damage on primary cutting edge and chisel edge! This means an end to tool life.

3 x D

5 x D

6 x D

8 x D

2-3.5 x D

5.3 Tool clamping

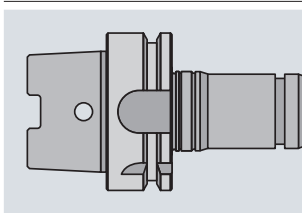
**Collet holders type PGR**

Concentricity < 3 µm

- Slender construction
- Reduced vibrations

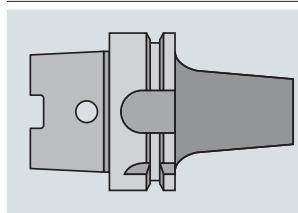
**Shrink-fit chucks**

Concentricity < 3 µm

- Slender construction

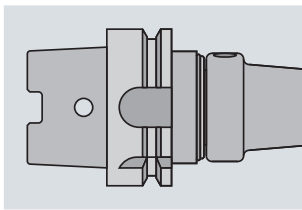
**Hydraulic expansion chucks**

Concentricity < 3 µm

- Reduced vibrations

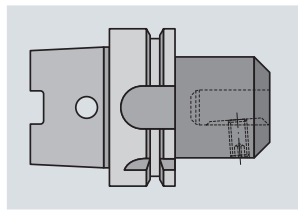

Tool holders for straight shanks with inclined clamping flat
Concentricity < 15 µm

- Economically efficient

5.4 Differences in tool clamping with lateral driving flat and inclined clamping flat

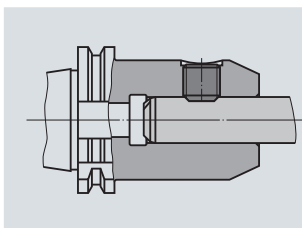
**Lateral driving flat**

Clamping of tools with lateral driving flat acc. DIN 6535 HB resp. DIN 1835 B. This type of clamping has **no** axial support and is therefore **not** suitable for drilling operations.

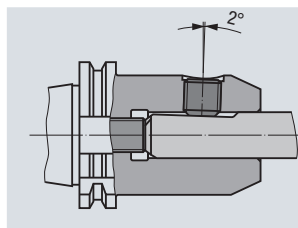
**Inclined clamping flat**

Clamping of tools with inclined clamping flat acc. DIN 6535 HE resp. DIN 1835 E.

- Product Finder
- v_c / f
- STEEL
- VA
- Accessories
- Tech. Info

5.5 Workpiece clamping

Basic conditions for the use of twist drills:

- The workpiece must be firmly supported, without a chance to bounce or bend
- Additional support points will help
- With thin-walled workpieces, feed must be reduced

Solid carbide twist drills are extremely sensitive to bending stress!

Wrong workpiece clamping	Correct workpiece clamping

- 3 x D
- 5 x D
- 6 x D
- 8 x D
- 2-3.5 x D



5.6 Coolant supply

Internal cooling is always to be recommended when drill depth exceeds $2 \times D$. From a drill depth of $5 \times D$, it is absolutely necessary. With external cooling, make sure to provide not only sufficient coolant pressure but also the right type of supply.

Wherever possible, three coolant-lubricant jets should hit the twist drill directly.

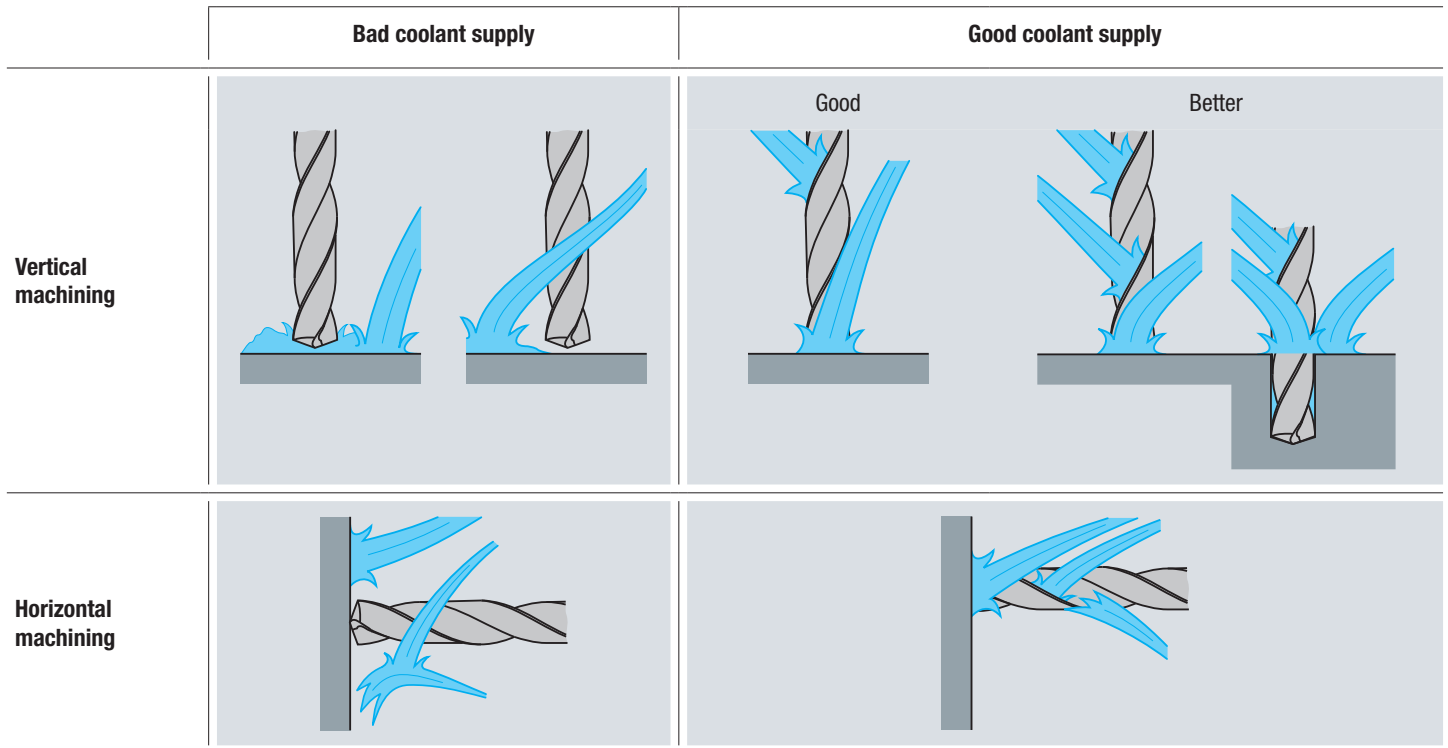

- 3 x D
- 5 x D
- 6 x D
- 8 x D
- 2-3.5 x D

5.7 Point angle

Centering and pilot hole

With large clamping-related extension lengths, it is necessary to provide either a centering or a pilot hole.

With tool lengths exceeding $8 \times D$, it is highly recommended to either start drilling with reduced feed, or to provide a centering or a pilot hole.

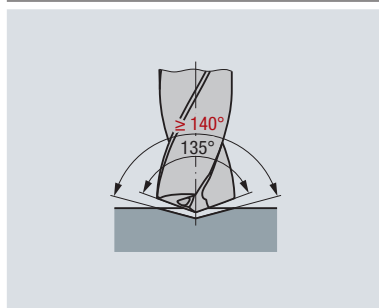

Centering

Please note that the point angle of the first, or preparatory drill must be larger than that of the subsequent drill. We recommend our twist drills EF-Drill acc. DIN 6537 K. The centering should not be deeper than the point length l_5 .

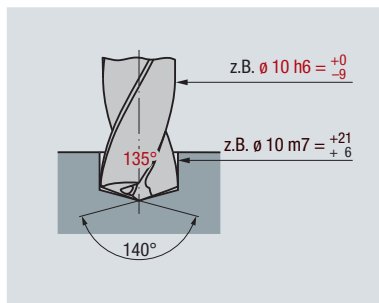

Pilot hole

A pilot hole is used for deep-hole drilling. Please note that the point angle and the diameter of the pilot drill must be larger than those of the subsequent drill. For the pilot hole, a depth of $1 \times D$ is sufficient.



- Product Finder
- v_c / f
- STEEL
- VA
- Accessories
- Tech. Info

5.8 Influence of the point angle

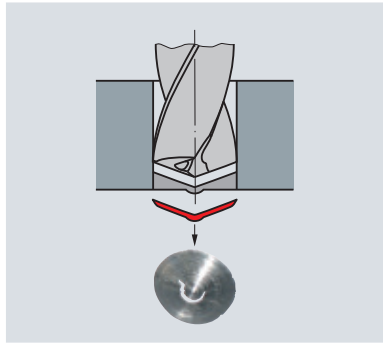

Standard point angle 140° (EF-Drill)

- Stable point
- Short chips
- Good centering
- Reduced power consumption
- Reduced torque
- Formation of slug
- Minimal burr formation
- Long tool life

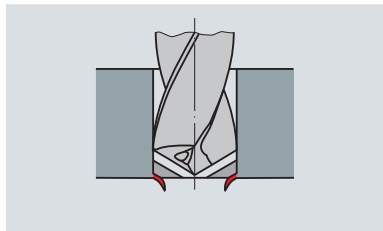

Point angle 118°

- Unstable point
- High torque
- High power consumption
- Unstable primary cutting edges
- Slug formation very much reduced
- Formation of burr during the exit of the drill

5.9 Reduce feed on angled entry / exit surfaces

The EMUGE double margin design provides excellent guiding ability that is especially effective in work with transverse holes or angled exits.

The EMUGE EF-Drill self-centers primarily by means of the chisel edge. With slanted, concave, convex or very rough entry surfaces, the tool is deflected. That is why feed must be reduced in the first drilling stage.

- 3 x D
- 5 x D
- 6 x D
- 8 x D
- 2-3.5 x D

Angled entry surfaces	Angled or rounded exit surfaces
<p>Feed must be reduced during the first drilling stage:</p> <ul style="list-style-type: none"> • DIN 6537 short (3 x d_1) <ul style="list-style-type: none"> 1...2°: by 20% 2...3°: by 40% 3...4°: by 50% 4...5°: by 70% • DIN 6537 long (5 x d_1) <ul style="list-style-type: none"> < 1°: by 30% 1...2°: by 40% 2...3°: by 50% 	<p>Feed must be reduced during the breaking through stage:</p> <ul style="list-style-type: none"> • For EF-Drill with single margin by 70% • For EF-Drill with double margins by 50%

5.10 Proper edge preparation (honing)

Every drill has an edge preparation (hone) which is in relation to the drill diameter and material to be cut.

The edge preparation is for stabilizing the cutting edge. The feed is in relation to the edge preparation and material.

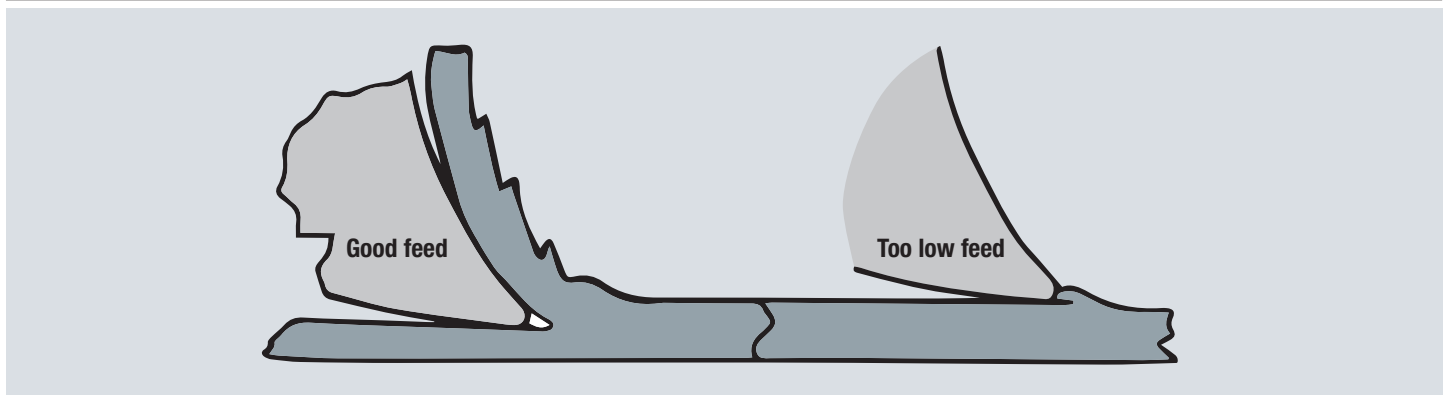

5.11 Technical information EF-Drill Micro

Product Finder

v_c / f

STEEL

VA

Accessories

Tech. Info

Recommended coolant pressure EF-Drill Micro

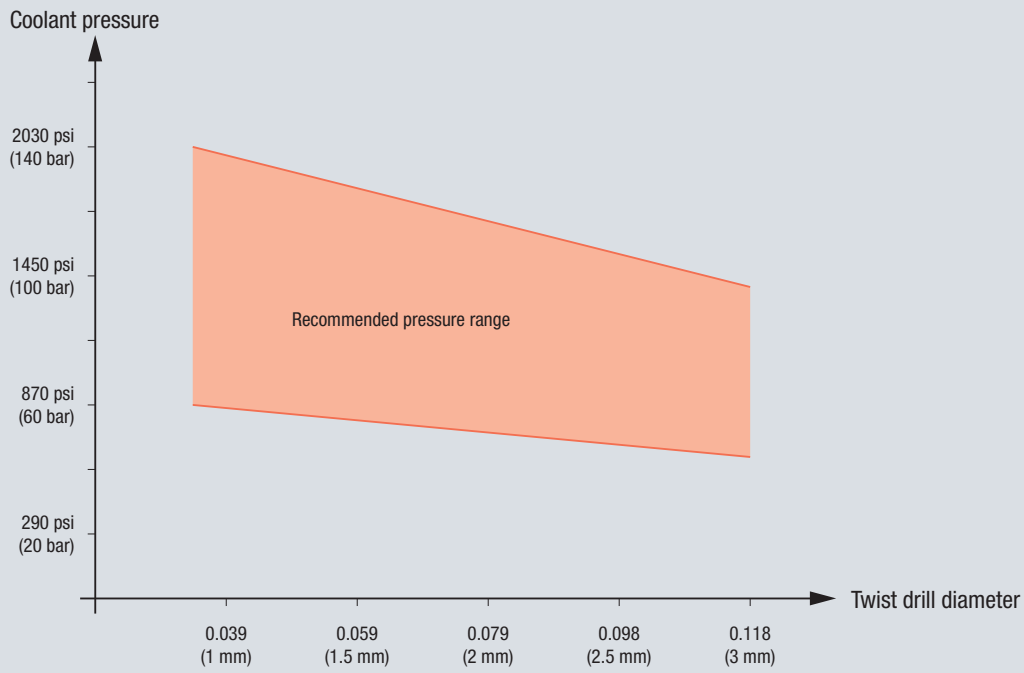

3 x D

5 x D

6 x D

8 x D

2-3.5 x D

Coolant-lubricant flow rate EF-Drill Micro

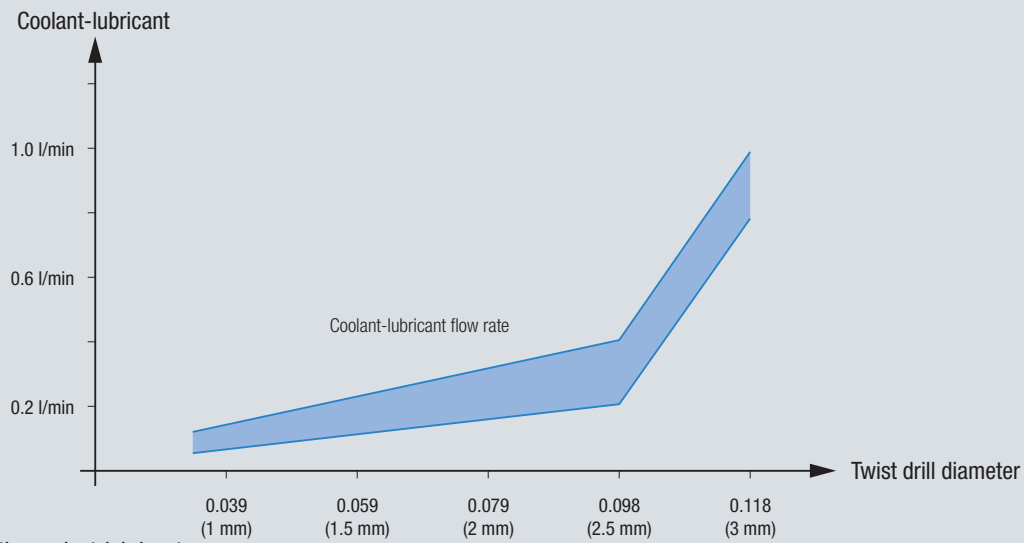



Use a micro filter for the coolant-lubricant



- Product Finder
- v_c / f
- STEEL
- VA
- Accessories
- Tech. Info

5.12 Technical information EF-Drill Modular

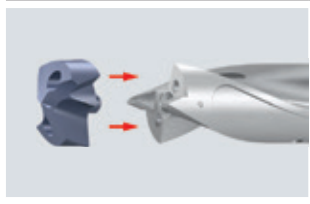
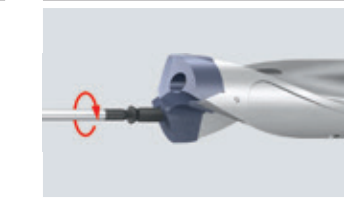
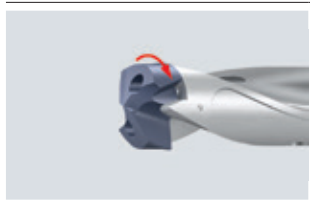
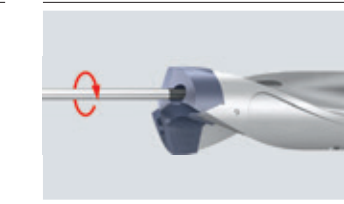
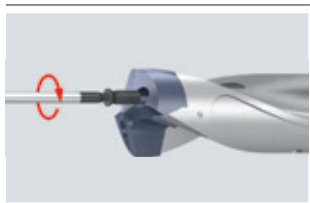
Assembly of drill head into holder

	<p>1. Insert the cutting head into the cleaned holder.</p>		<p>4. Insert the second screw into the mounting bore and tighten it firmly.</p>
	<p>2. Turn the cutting head clockwise up to the stop.</p>		<p>5. Tighten the first screw with the recommended torque. Retighten the second screw with the recommended torque.</p>
	<p>3. Insert a screw into the mounting bore and tighten it gently.</p>		<p>6. Tool completely assembled.</p>

- 3 x D
- 5 x D
- 6 x D
- 8 x D
- 2-3.5 x D

Tightening torques for clamping screws

	Size of insert seat	Size	Rec. tightening torque	
			ft lbs	Nm
	2	Torx T7	0.44	0.60
	3	Torx T8	0.65	0.88
	4	Torx T8	1.13	1.53
	5	Torx T9	1.80	2.44
	6	Torx T15	2.70	3.66
	7	Torx T15	3.85	5.22

Machining condition

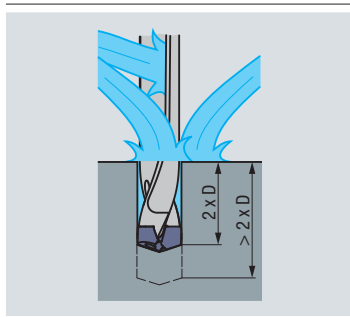
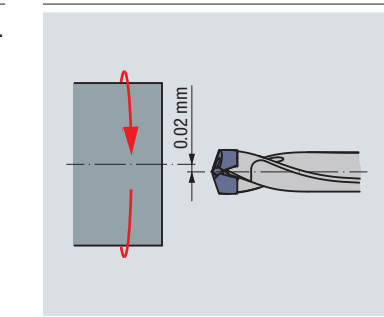
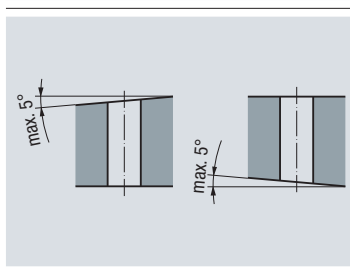
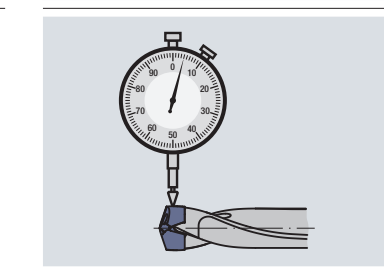
	<p>External cooling possible up to 2 x D. From 2 x D drill in steps.</p> <p>Internal cooling should always be preferred. Recommended coolant pressure: > 20 bar.</p>		<p>Maximum axle offset 0.02 mm.</p>
	<p>Slanting entering and exit ≤ 5°.</p>		<p>Maximum run-out < 0.04 mm.</p>

5.13 Problems, possible causes and solutions in drilling

Product
FinderV_c / f

STEEL

VA

Accessories

Tech. Info

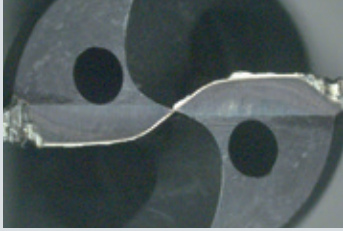
**Problems:**

- Excessive wear on the corners
- Built-up edge
- Wear on the margins

Possible causes:

- Excessive machining times
- High temperature and/or friction
- Concentricity run-out > 0.02 mm
- Unstable clamping of workpiece or tool
- Coolant-lubricant too dry

Solutions:

- Exchange twist drill in time and regrind
- Increase coolant-lubricant volume
- Use coolant-lubricant with higher oil content, or additives
- Reduce cutting speed
- Reduce feed for drilling through

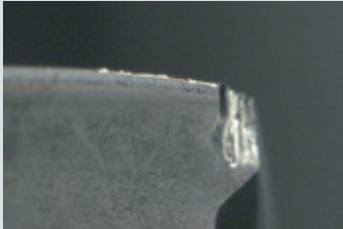
**Problem:**

- Chipping on the cutting corners

Possible causes:

- Excessive feed
- Workpiece moves when the drill breaks through
- Machine is unstable
- Twist drill slips due to unsatisfactory tool clamping
- Concentricity run-out > 0.02 mm

Solutions:

- Improve workpiece clamping
- Use a different clamping tool, e.g. clamping system PGR or hydraulic expansion chuck
- Reduce feed

3 x D

5 x D

6 x D

8 x D

2-3.5 x D

**Problem:**

- Coating coming off on the margins

Possible causes:

- Excessive friction
- Slanted exit
- Adhesive workpiece material
- Reground too many times (excessive coating thickness)

Solutions:

- Use coolant-lubricant with higher oil content, or additives
- Reduce feed for exiting
- Reduce the number of times you regrind your drills



5.13 Problems, possible causes and solutions in drilling



Problem:

- Built-up edge on the primary cutting edge

Possible causes:

- Wrong cutting data
- Excessive wear on relief surfaces
- Damage on the cutting edges
- Bad coolant supply

Solutions:

- Use coolant-lubricant with higher oil content, or additives
- Increase cutting speed
- Reduce feed
- Exchange tools



Problem:

- Splintering on the chisel edge

Possible causes:

- Vibrations
- Concentricity run-out > 0.02 mm
- Rough or slanted workpiece surface

Solutions:

- Reduce feed
- Use a different clamping tool
- Improve workpiece surface (e.g. by spot-facing)



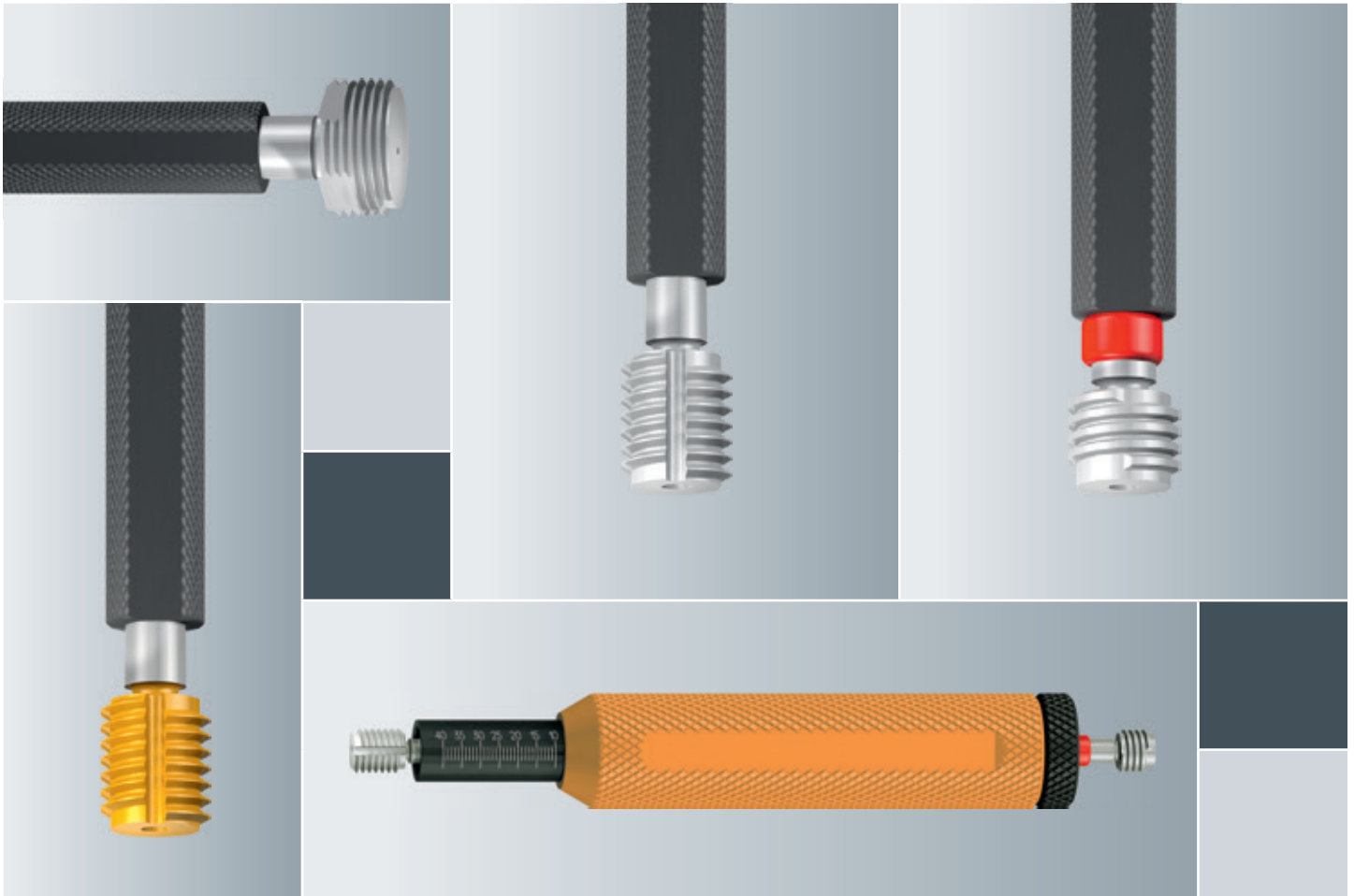

Thread Gages

	Page
Contents	430 - 431
Product Pages	432 - 466
Technical Information	467 - 476



- Product Finder
- UNC
- UNF
- UNS
- M
- MF
- G (BSP)
- Rp, R, Rc
- NPT
- NPTF
- STI
- SELF-LOCK
- Smooth
- GT, TD
- Accessories
- Calibration
- Tech. Info

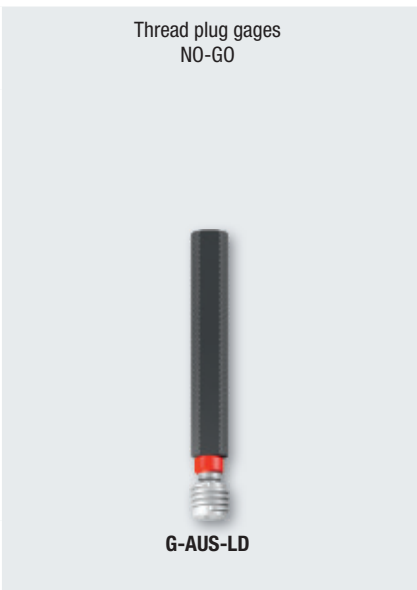
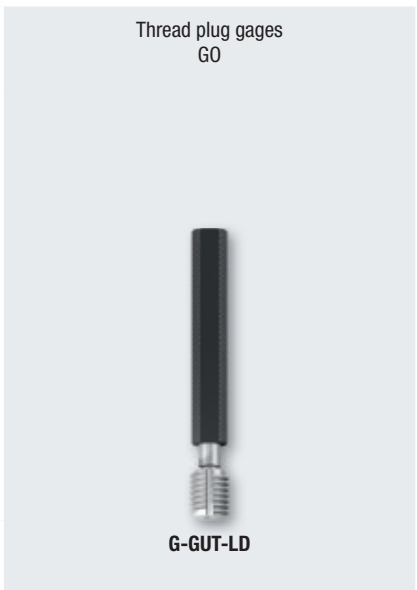
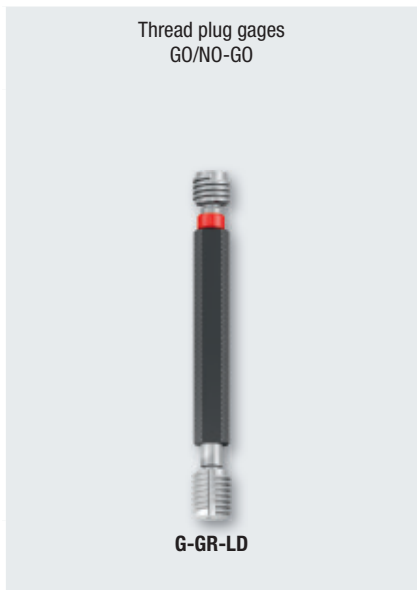

	Page		
UNC	432	432	432
UNF	433	433	433
UNS	434		
M	435 - 437	437	437
MF	439 - 441	442 - 448	443 - 449
G (BSP)	450	450	450
Rp, R, Rc			
NPT			
NPTF			
STI-M	454		
LK-UNC	455		
LK-UNF	456		
LK-M	457		

	Page
 <p style="text-align: center;">Smooth plug gages GO/NO-GO, GO, and NO-GO</p>	458
 <p style="text-align: center;">Smooth plug gages GO/NO-GO for thread holes, for Metric threads</p>	459

Thread gages
for tapered threads



G-GR-LD, G-GR-LR

Thread depth
plug gages



GT-GR-LD
"analog"



TD-Bit-GUT
"analog"

Page

	460	460	UNC
	461	461	UNF
			UNS
	462	462	M
			MF
	463	463	G (BSP)
451			Rp, R, Rc
452			NPT
453			NPTF
			STI-M
			LK-UNC
			LK-UNF
			LK-M

Product
Finder

- UNC
- UNF
- UNS
- M
- MF
- G (BSP)
- Rp, R, Rc
- NPT
- NPTF
- STI
- SELF-LOCK
- Smooth
- GT, TD
- Accessories
- Calibration

Tech. Info



Hexagon bit adapters and accessories

Page

464



DECOM Calibration Laboratory at EMUGE

465



- Product Finder
- UNC**
- UNF
- UNS
- M
- MF
- G (BSP)
- Rp, R, Rc
- NPT
- NPTF
- STI
- SELF-LOCK
- Smooth
- GT, TD
- Accessories
- Calibration
- Tech. Info



**Unified Coarse Thread
ASME B1.1**

Gage dimensions acc. ANSI/ASME B1.2



Class of Fit
Coating

2B

3B

2B

2B

Tool Identification

L0100100

L0100110

L0120100

L0140100

Dimens.
ID

G-GR-LD

G-GR-LD

G-GUT-LD

G-AUS-LD

Nominal
Size
 $\varnothing d_1$

T.P.I.

No.	T.P.I.	Dimens. ID	G-GR-LD	G-GR-LD	G-GUT-LD	G-AUS-LD
No. 1	64	.5000	●		*	*
No. 2	56	.5001	●		*	*
No. 3	48	.5002	●		*	*
No. 4	40	.5003	●		*	*
No. 5	40	.5004	●		*	*
No. 6	32	.5005	●		*	*
No. 8	32	.5006	●		*	*
No. 10	24	.5007	●		*	*
No. 12	24	.5008	●		*	*
1/4	20	.5009	●		*	*
5/16	18	.5010	●		*	*
3/8	16	.5011	●		*	*
7/16	14	.5012	●	●	*	*
1/2	13	.5013	●	●	*	*
9/16	12	.5014	●	●	*	*
5/8	11	.5015	●	●	*	*
3/4	10	.5016	●	●	*	*
7/8	9	.5017	●		*	*
1	8	.5018	●		*	*
1 1/8	7	.5019	●		*	*
1 1/4	7	.5020	●		*	*
1 3/8	6	.5021	●		*	*
1 1/2	6	.5022	●		*	*
1 3/4	5	.5023			*	*
2	4 1/2	.5024			*	*

> $\varnothing 1 \frac{1}{2}$ available only as separate plug gages (G-GUT-LD, G-AUS-LD)

Thread gages for UNEF and UN upon request

Short Form Certificate of Accuracy is furnished free with each gage,
Long Form Certificates are available upon request



Thread ring gages GO/NO-GO upon request

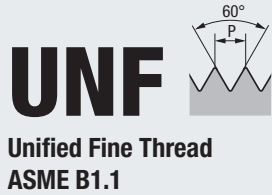

Gage dimensions acc. ANSI/ASME B1.2



Class of Fit	2B	3B	2B	2B
Coating				

Nominal Size ø d ₁	T.P.I.	Tool Identification Dimens. ID	L0100100	L0100110	L0120100	L0140100
			G-GR-LD	G-GR-LD	G-GUT-LD	G-AUS-LD
No. 0	80	.5033	●		★	★
No. 1	72	.5034	●		★	★
No. 2	64	.5035	●		★	★
No. 3	56	.5036	●		★	★
No. 4	48	.5037	●		★	★
No. 5	44	.5038	●		★	★
No. 6	40	.5039	●		★	★
No. 8	36	.5040	●		★	★
No. 10	32	.5041	●		★	★
No. 12	28	.5042	●		★	★
1/4	28	.5043	●		★	★
5/16	24	.5044	●		★	★
3/8	24	.5045	●	●	★	★
7/16	20	.5046	●	●	★	★
1/2	20	.5047	●	●	★	★
9/16	18	.5048	●	●	★	★
5/8	18	.5049	●	●	★	★
3/4	16	.5050	●	●	★	★
7/8	14	.5051	●		★	★
1	12	.5052	●		★	★
1 1/8	12	.5053	●		★	★
1 1/4	12	.5054	●		★	★
1 3/8	12	.5055	●		★	★
1 1/2	12	.5056	●		★	★

Short Form Certificate of Accuracy is furnished free with each gage,
Long Form Certificates are available upon request

Thread gages for UNEF and UN upon request

- Product Finder
- UNC
- UNF
- UNS
- M
- MF
- G (BSP)
- Rp, R, Rc
- NPT
- NPTF
- STI
- SELF-LOCK
- Smooth
- GT, TD
- Accessories
- Calibration
- Tech. Info



Thread ring gages GO/NO-GO upon request

● = In stock
★ = Allow 7 days for delivery



- Product Finder
- UNC
- UNF
- UNS**
- M
- MF
- G (BSP)
- Rp, R, Rc
- NPT
- NPTF
- STI
- SELF-LOCK
- Smooth
- GT, TD
- Accessories
- Calibration
- Tech. Info

UNS



**Unified Thread
ASME B1.1**

Gage dimensions acc. ANSI/ASME B1.2



		Class of Fit			
		Coating			
		Tool Identification			
Nominal Size $\varnothing d_1$	T.P.I.	Dimens. ID			
1	14	.5404	•	•	

Short Form Certificate of Accuracy is furnished free with each gage,
Long Form Certificates are available upon request



Thread ring gages GO/NO-GO upon request

M



**ISO Metric Coarse Thread
DIN 13**



Gage dimensions acc. ASME B1.16M

Class of Fit
Coating

6H

Tool Identification

LU100100

Dimens.
ID

G-GR-LD

Nominal Size $\varnothing d_1$	P mm	Dimens. ID					
M 1.6	0.35	.0016	●				
M 2	0.4	.0020	●				
M 2.5	0.45	.0025	●				
M 3	0.5	.0030	●				
M 3.5	0.6	.0035	●				
M 4	0.7	.0040	●				
M 5	0.8	.0050	●				
M 6	1	.0060	●				
M 8	1.25	.0080	●				
M 10	1.5	.0100	●				
M 11	1.5	.0111	●				
M 12	1.75	.0112	●				
M 14	2	.0114	●				
M 16	2	.0116	●				
M 18	2.5	.0118	●				
M 20	2.5	.0120	●				
M 22	2.5	.0122	●				
M 24	3	.0124	●				
M 30	3.5	.0130	●				
M 36	4	.0136	●				

Short Form Certificate of Accuracy is furnished free with each gage,
Long Form Certificates are available upon request

Product
Finder

UNC

UNF

UNS

M

MF

G (BSP)

Rp, R, Rc

NPT

NPTF

STI

SELF-LOCK

Smooth

GT, TD

Accessories

Calibration

Tech. Info



Thread ring gages GO/NO-GO upon request

● = In stock
★ = Allow 7 days for delivery



- Product Finder
- UNC
- UNF
- UNS
- M**
- MF
- G (BSP)
- Rp, R, Rc
- NPT
- NPTF
- STI
- SELF-LOCK
- Smooth
- GT, TD
- Accessories
- Calibration
- Tech. Info

M



**ISO Metric Coarse Thread
DIN 13**

Gage dimensions acc. DIN ISO 1502

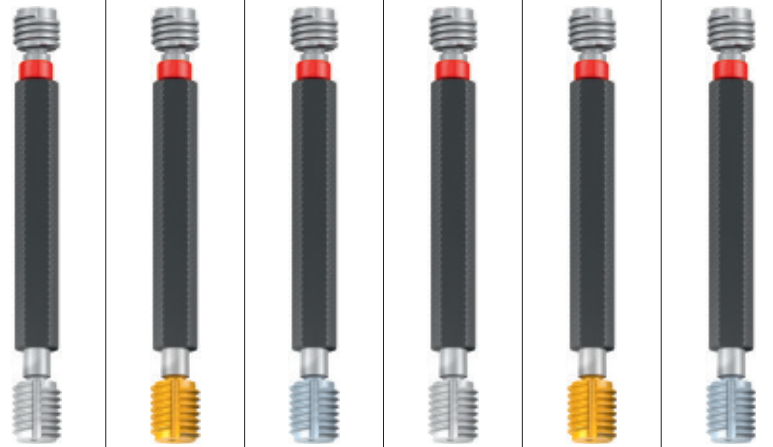

		Class of Fit	6H	6H	6H	4H	4H	4H
		Coating		TIN	CR		TIN	CR
		Tool Identification	L0100100	L0105100	L0101100	L0100110	L0105110	L0101110
Nominal Size ø d ₁	P mm	Dimens. ID	G-GR-LD	G-GR-LD	G-GR-LD	G-GR-LD	G-GR-LD	G-GR-LD
				TIN	CR		TIN	CR
M 1	0.25	.0010	*)					
M 1.1	0.25	.0011	*)					
M 1.2	0.25	.0012	*)					
M 1.4	0.3	.0014	*)					
M 1.6	0.35	.0016	*					
M 1.7	0.35	.0017	*					
M 1.8	0.35	.0018	*					
M 2	0.4	.0020	*			*	upon	upon
M 2.2	0.45	.0022	*			*		
M 2.3	0.4	.0023	*				request	request
M 2.5	0.45	.0025	*			*		
M 2.6	0.45	.0026	*					
M 3	0.5	.0030	*	*	*	*		
M 3.5	0.6	.0035	*	*	*	*		
M 4	0.7	.0040	*	*	*	*		
M 4.5	0.75	.0045	*	*	*	*		
M 5	0.8	.0050	*	*	*	*		
M 6	1	.0060	*	*	*	*		
M 7	1	.0070	*	*	*	*		
M 8	1.25	.0080	*	*	*	*		
M 9	1.25	.0090	*	*	*	*		
M 10	1.5	.0100	*	*	*	*		
M 11	1.5	.0111	*	*	*	*		
M 12	1.75	.0112	*	*	*	*		
M 14	2	.0114	*	*	*	*		
M 16	2	.0116	*	*	*	*		
M 18	2.5	.0118	*	*	*	*		
M 20	2.5	.0120	*	*	*	*		
M 22	2.5	.0122	*	*	*	*		
M 24	3	.0124	*	*	*	*		
M 27	3	.0127	*	*	*	*		
M 30	3.5	.0130	*	*	*	*		
M 33	3.5	.0133	*	*	*	*		
M 36	4	.0136	*	*	*	*		
M 39	4	.0139	*	*	*	*		
M 42	4.5	.0142	*	*	*	*		
M 45	4.5	.0145	*	*	*	*		
M 48	5	.0148	*	*	*	*		
M 52	5	.0152	*	*	*	*		
M 56	5.5	.0156	*	*	*	*		
M 60	5.5	.0160	*	*	*	*		
M 64	6	.0164	*	*	*	*		
M 68	6	.0168	*	*	*	*		

*) ≤ M1.4 Class of Fit "5H"

Short Form Certificate of Accuracy is furnished free with each gage,
Long Form Certificates are available upon request

									Class of Fit Coating	Nominal Size ø d ₁	P mm
6G	6G TIN	6G CR	6E	6H LH	6H	6H TIN	6H CR	6H			
L0100120 G-GR-LD	L0105120 G-GR-LD TIN	L0101120 G-GR-LD CR	L0100130 G-GR-LD	L0100150 G-GR-LD LH	L0120100 G-GUT-LD	L0125100 G-GUT-LD TIN	L0121100 G-GUT-LD CR	L0140100 G-AUS-LD			
					★*)			★*)	M 1	0.25	
					★*)			★*)	M 1.1	0.25	
					★*)			★*)	M 1.2	0.25	
					★*)			★*)	M 1.4	0.3	
					★			★	M 1.6	0.35	
					★			★	M 1.7	0.35	
					★			★	M 1.8	0.35	
★	upon	upon		★	★			★	M 2	0.4	
★	request	request		★	★			★	M 2.2	0.45	
★				★	★			★	M 2.3	0.4	
				★	★			★	M 2.5	0.45	
★			★	★	★	★	★	★	M 2.6	0.45	
★			★	★	★	★	★	★	M 3	0.5	
★			★	★	★	★	★	★	M 3.5	0.6	
★			★	★	★	★	★	★	M 4	0.7	
					★			★	M 4.5	0.75	
★			★	★	★	★	★	★	M 5	0.8	
★			★	★	★	★	★	★	M 6	1	
					★			★	M 7	1	
★			★	★	★	★	★	★	M 8	1.25	
★			★	★	★	★	★	★	M 9	1.25	
					★			★	M 10	1.5	
★				★	★	★	★	★	M 11	1.5	
★				★	★	★	★	★	M 12	1.75	
★				★	★	★	★	★	M 14	2	
★				★	★	★	★	★	M 16	2	
★				★	★	★	★	★	M 18	2.5	
★				★	★	★	★	★	M 20	2.5	
★				★	★	★	★	★	M 22	2.5	
★				★	★	★	★	★	M 24	3	
					★			★	M 27	3	
					★			★	M 30	3.5	
					★			★	M 33	3.5	
					★			★	M 36	4	
					★			★	M 39	4	
					★			★	M 42	4.5	
					★			★	M 45	4.5	
					★			★	M 48	5	
					★			★	M 52	5	
					★			★	M 56	5.5	
					★			★	M 60	5.5	
					★			★	M 64	6	
					★			★	M 68	6	

> ø 40 mm available only as separate plug gages (G-GUT-LD, G-AUS-LD)



Thread ring gages GO/NO-GO upon request

● = In stock
★ = Allow 7 days for delivery



- Product Finder
- UNC
- UNF
- UNS
- M
- MF
- G (BSP)
- Rp, R, Rc
- NPT
- NPTF
- STI
- SELF-LOCK
- Smooth
- GT, TD
- Accessories
- Calibration
- Tech. Info



MF



ISO Metric Fine Thread
DIN 13



Gage dimensions acc. ASME B1.16M

- Product Finder
- UNC
- UNF
- UNS
- M
- MF**
- G (BSP)
- Rp, R, Rc
- NPT
- NPTF
- STI
- SELF-LOCK
- Smooth
- GT, TD
- Accessories
- Calibration
- Tech. Info

			Class of Fit	6H				
			Coating					
			Tool Identification	LU100100				
			Dimens. ID	G-GR-LD				
Nominal Size ø d ₁		P mm	Dimens. ID					
M 5	x	0.5	.0218	●				
M 6	x	0.75	.0229	●				
M 8	x	0.75	.0250	●				
M 8	x	1	.0251	●				
M 10	x	1	.0276	●				
M 10	x	1.25	.0277	●				
M 12	x	1.25	.0302	●				
M 12	x	1.5	.0303	●				
M 14	x	1.5	.0331	●				
M 15	x	1.5	.0345	●				
M 16	x	1.5	.0359	●				
M 18	x	1.5	.0390	●				
M 20	x	1.5	.0422	●				
M 22	x	1.5	.0438	●				

Short Form Certificate of Accuracy is furnished free with each gage,
Long Form Certificates are available upon request



Thread ring gages GO/NO-GO upon request

● = In stock
★ = Allow 7 days for delivery



- Product Finder
- UNC
- UNF
- UNS
- M
- MF**
- G (BSP)
- Rp, R, Rc
- NPT
- NPTF
- STI
- SELF-LOCK
- Smooth
- GT, TD
- Accessories
- Calibration
- Tech. Info

MF



**ISO Metric Fine Thread
DIN 13**

Gage dimensions acc. DIN ISO 1502

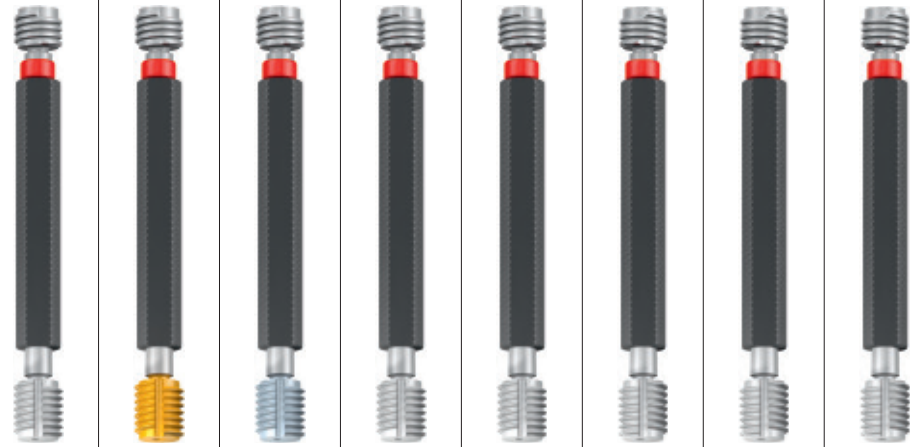

		Class of Fit	6H	6H	6H	4H	6G	6H	4H	6G
		Coating		TIN	CR			LH	LH	LH
		Tool Identification	L0100100	L0105100	L0101100	L0100110	L0100120	L0100150	L0100160	L0100170
		Dimens. ID	G-GR-LD	G-GR-LD	G-GR-LD	G-GR-LD	G-GR-LD	G-GR-LD LH	G-GR-LD LH	G-GR-LD LH
$\varnothing d_1$ mm	P mm			TIN 1)	CR 1)					
M 2	x 0.25	.0186				*				
M 2.2	x 0.25	.0189				*				
M 2.3	x 0.25	.0192				*				
M 2.5	x 0.35	.0196	*							
M 2.6	x 0.35	.0199	*							
M 3	x 0.35	.0202	*					*		
M 3.5	x 0.35	.0205	*					*		
M 4	x 0.35	.0209	*					*		
M 4	x 0.5	.0210	*			*	*	*		
M 4.5	x 0.5	.0214	*							
M 5	x 0.5	.0218	*			*	*	*		
M 6	x 0.5	.0228	*			*	*	*		
M 6	x 0.75	.0229	*			*	*	*		
M 7	x 0.75	.0239	*							
M 8	x 0.5	.0249	*							
M 8	x 0.75	.0250	*			*	*	*		
M 8	x 1	.0251	*	*	*	*	*	*	*	*
M 9	x 1	.0263	*			*	*	*	*	*
M 10	x 0.75	.0275	*			*	*	*	*	*
M 10	x 1	.0276	*	*	*	*	*	*	*	*
M 10	x 1.25	.0277	*			*	*	*	*	*
M 11	x 1	.0288	*			*	*	*	*	*
M 12	x 1	.0301	*	*	*	*	*	*	*	*
M 12	x 1.25	.0302	*			*	*	*	*	*
M 12	x 1.5	.0303	*	*	*	*	*	*	*	*
M 13	x 1	.0315	*			*	*	*	*	*
M 13	x 1.5	.0317	*			*	*	*	*	*
M 14	x 1	.0329	*			*	*	*	*	*
M 14	x 1.25	.0330	*			*	*	*	*	*
M 14	x 1.5	.0331	*	*	*	*	*	*	*	*
M 15	x 1	.0343	*			*	*	*	*	*
M 15	x 1.5	.0345	*			*	*	*	*	*
M 16	x 1	.0357	*			*	*	*	*	*
M 16	x 1.5	.0359	*	*	*	*	*	*	*	*
M 17	x 1	.0372	*			*	*	*	*	*
M 17	x 1.5	.0374	*			*	*	*	*	*
M 18	x 1	.0388	*			*	*	*	*	*
M 18	x 1.5	.0390	*	*	*	*	*	*	*	*
M 18	x 2	.0391	*			*	*	*	*	*
M 19	x 1	.0404	*			*	*	*	*	*
M 20	x 1	.0420	*			*	*	*	*	*
M 20	x 1.5	.0422	*	*	*	*	*	*	*	*
M 20	x 2	.0423	*			*	*	*	*	*
M 21	x 1	.0428	*			*	*	*	*	*
M 22	x 1	.0436	*			*	*	*	*	*
M 22	x 1.5	.0438	*			*	*	*	*	*
M 22	x 2	.0439	*			*	*	*	*	*
M 23	x 1	.0443	*			*	*	*	*	*
M 24	x 1	.0450	*			*	*	*	*	*
M 24	x 1.5	.0452	*			*	*	*	*	*
M 24	x 2	.0453	*			*	*	*	*	*

MF



ISO Metric Fine Thread
DIN 13

Gage dimensions acc. DIN ISO 1502

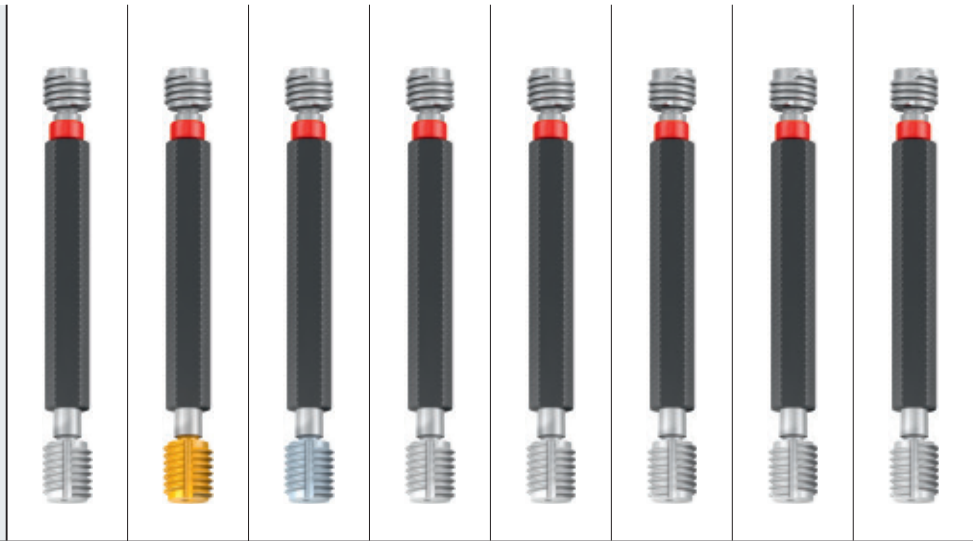

		Class of Fit	Coating							
			6H	6H TIN	6H CR	4H	6G	6H LH	4H LH	6G LH
		Tool Identification	L0100100	L0105100	L0101100	L0100110	L0100120	L0100150	L0100160	L0100170
		Dimens. ID	G-GR-LD	G-GR-LD TIN 1)	G-GR-LD CR 1)	G-GR-LD	G-GR-LD	G-GR-LD LH	G-GR-LD LH	G-GR-LD LH
ø d ₁ mm	P mm									
M 25	x 1	.0456	★			★	★	★	★	★
M 25	x 1.5	.0458	★			★	★	★	★	★
M 25	x 2	.0459	★			★	★	★	★	★
M 26	x 1	.0462	★			★	★	★	★	★
M 26	x 1.5	.0464	★			★	★	★	★	★
M 26	x 2	.0465	★			★	★	★	★	★
M 27	x 1	.0468	★			★	★	★	★	★
M 27	x 1.5	.0470	★			★	★	★	★	★
M 27	x 2	.0471	★			★	★	★	★	★
M 28	x 1	.0474	★			★	★	★	★	★
M 28	x 1.5	.0476	★			★	★	★	★	★
M 28	x 2	.0477	★			★	★	★	★	★
M 30	x 1	.0488	★			★	★	★	★	★
M 30	x 1.5	.0490	★			★	★	★	★	★
M 30	x 2	.0491	★			★	★	★	★	★
M 30	x 3	.0492	★			★	★	★	★	★
M 32	x 1	.0502	★			★	★	★	★	★
M 32	x 1.5	.0504	★			★	★	★	★	★
M 32	x 2	.0505	★			★	★	★	★	★
M 33	x 1	.0509	★			★	★	★	★	★
M 33	x 1.5	.0511	★			★	★	★	★	★
M 33	x 2	.0512	★			★	★	★	★	★
M 33	x 3	.0513	★			★	★	★	★	★
M 34	x 1	.0516	★			★	★	★	★	★
M 34	x 1.5	.0518	★			★	★	★	★	★
M 34	x 2	.0519	★			★	★	★	★	★
M 35	x 1	.0523	★			★	★	★	★	★
M 35	x 1.5	.0525	★			★	★	★	★	★
M 35	x 2	.0526	★			★	★	★	★	★
M 36	x 1	.0530	★			★	★	★	★	★
M 36	x 1.5	.0532	★			★	★	★	★	★
M 36	x 2	.0533	★			★	★	★	★	★
M 36	x 3	.0534	★			★	★	★	★	★
M 38	x 1	.0544	★			★	★	★	★	★
M 38	x 1.5	.0546	★			★	★	★	★	★
M 38	x 2	.0547	★			★	★	★	★	★
M 39	x 1	.0551	★			★	★	★	★	★
M 39	x 1.5	.0553	★			★	★	★	★	★
M 39	x 2	.0554	★			★	★	★	★	★
M 39	x 3	.0555	★			★	★	★	★	★
M 40	x 1	.0558	★			★	★	★	★	★
M 40	x 1.5	.0560	★			★	★	★	★	★
M 40	x 2	.0561	★			★	★	★	★	★
M 40	x 3	.0562	★			★	★	★	★	★

> ø 40 mm available only as separate plug gages (G-GUT-LD, G-AUS-LD), see page 442 - 449

1) Class of Fit "4H" and "6G" upon request

Short Form Certificate of Accuracy is furnished free with each gage,
Long Form Certificates are available upon request



Thread ring gages GO/NO-GO upon request

● = In stock
★ = Allow 7 days for delivery

- Product Finder
- UNC
- UNF
- UNS
- M
- MF**
- G (BSP)
- Rp, R, Rc
- NPT
- NPTF
- STI
- SELF-LOCK
- Smooth
- GT, TD
- Accessories
- Calibration
- Tech. Info



- Product Finder
- UNC
- UNF
- UNS
- M
- MF**
- G (BSP)
- Rp, R, Rc
- NPT
- NPTF
- STI
- SELF-LOCK
- Smooth
- GT, TD
- Accessories
- Calibration
- Tech. Info

MF



**ISO Metric Fine Thread
DIN 13**

Gage dimensions acc. DIN ISO 1502

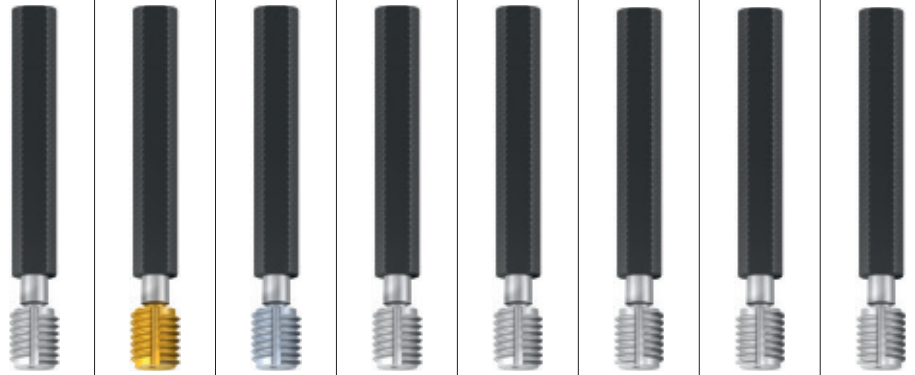

		Class of Fit	6H	6H	6H	4H	6G	6H	4H	6G
		Coating		TIN	CR			LH	LH	LH
		Tool Identification	L0120100	L0125100	L0121100	L0120110	L0120120	L0120150	L0120160	L0120170
		Dimens. ID	G-GUT-LD	G-GUT-LD TIN	G-GUT-LD CR	G-GUT-LD	G-GUT-LD	G-GUT-LD LH	G-GUT-LD LH	G-GUT-LD LH
$\varnothing d_1$ mm	P mm									
M 2	x 0.25	.0186								
M 2.2	x 0.25	.0189								
M 2.3	x 0.25	.0192								
M 2.5	x 0.35	.0196	*							
M 2.6	x 0.35	.0199	*							
M 3	x 0.35	.0202	*							
M 3.5	x 0.35	.0205	*							
M 4	x 0.35	.0209	*							
M 4	x 0.5	.0210	*							
M 4.5	x 0.5	.0214	*							
M 5	x 0.5	.0218	*							
M 6	x 0.5	.0228	*							
M 6	x 0.75	.0229	*							
M 7	x 0.75	.0239	*							
M 8	x 0.5	.0249	*							
M 8	x 0.75	.0250	*							
M 8	x 1	.0251	*	*	*	*	*	*	*	*
M 9	x 1	.0263	*			*	*	*	*	*
M 10	x 0.75	.0275	*			*	*	*	*	*
M 10	x 1	.0276	*	*	*	*	*	*	*	*
M 10	x 1.25	.0277	*			*	*	*	*	*
M 11	x 1	.0288	*			*	*	*	*	*
M 12	x 1	.0301	*	*	*	*	*	*	*	*
M 12	x 1.25	.0302	*			*	*	*	*	*
M 12	x 1.5	.0303	*	*	*	*	*	*	*	*
M 13	x 1	.0315	*			*	*	*	*	*
M 13	x 1.5	.0317	*			*	*	*	*	*
M 14	x 1	.0329	*			*	*	*	*	*
M 14	x 1.25	.0330	*			*	*	*	*	*
M 14	x 1.5	.0331	*	*	*	*	*	*	*	*
M 15	x 1	.0343	*			*	*	*	*	*
M 15	x 1.5	.0345	*			*	*	*	*	*
M 16	x 1	.0357	*			*	*	*	*	*
M 16	x 1.5	.0359	*	*	*	*	*	*	*	*
M 17	x 1	.0372	*			*	*	*	*	*
M 17	x 1.5	.0374	*			*	*	*	*	*
M 18	x 1	.0388	*			*	*	*	*	*
M 18	x 1.5	.0390	*	*	*	*	*	*	*	*
M 18	x 2	.0391	*			*	*	*	*	*
M 19	x 1	.0404	*			*	*	*	*	*
M 20	x 1	.0420	*			*	*	*	*	*
M 20	x 1.5	.0422	*	*	*	*	*	*	*	*
M 20	x 2	.0423	*			*	*	*	*	*
M 21	x 1	.0428	*			*	*	*	*	*
M 22	x 1	.0436	*			*	*	*	*	*
M 22	x 1.5	.0438	*			*	*	*	*	*
M 22	x 2	.0439	*			*	*	*	*	*
M 23	x 1	.0443	*			*	*	*	*	*
M 24	x 1	.0450	*			*	*	*	*	*
M 24	x 1.5	.0452	*			*	*	*	*	*
M 24	x 2	.0453	*			*	*	*	*	*

Product Finder

UNC

UNF

UNS

M

MF

G (BSP)

Rp, R, Rc

NPT

NPTF

STI

SELF-LOCK

Smooth

GT, TD

Accessories

Calibration

Tech. Info

										Class of Fit Coating	
6H	4H	6G	6H LH	4H LH	6G LH					Nominal Size ø d ₁	P mm
L0140100 G-AUS-LD	L0140110 G-AUS-LD	L0140120 G-AUS-LD	L0140150 G-AUS-LD LH	L0140160 G-AUS-LD LH	L0140170 G-AUS-LD LH						
										M 2 x 0.25	
										M 2.2 x 0.25	
										M 2.3 x 0.25	
*										M 2.5 x 0.35	
*										M 2.6 x 0.35	
*										M 3 x 0.35	
*										M 3.5 x 0.35	
*										M 4 x 0.35	
*										M 4 x 0.5	
*										M 4.5 x 0.5	
*										M 5 x 0.5	
*										M 6 x 0.5	
*										M 6 x 0.75	
*										M 7 x 0.75	
*										M 8 x 0.5	
*										M 8 x 0.75	
*	*	*	*	*	*					M 8 x 1	
*	*	*	*	*	*					M 9 x 1	
*										M 10 x 0.75	
*	*	*	*	*	*					M 10 x 1	
*										M 10 x 1.25	
*	*	*	*	*	*					M 11 x 1	
*	*	*	*	*	*					M 12 x 1	
*										M 12 x 1.25	
*	*	*	*	*	*					M 12 x 1.5	
*	*	*	*	*	*					M 13 x 1	
*	*	*	*	*	*					M 13 x 1.5	
*	*	*	*	*	*					M 14 x 1	
*										M 14 x 1.25	
*	*	*	*	*	*					M 14 x 1.5	
*	*	*	*	*	*					M 15 x 1	
*	*	*	*	*	*					M 15 x 1.5	
*	*	*	*	*	*					M 16 x 1	
*	*	*	*	*	*					M 16 x 1.5	
*	*	*	*	*	*					M 17 x 1	
*	*	*	*	*	*					M 17 x 1.5	
*	*	*	*	*	*					M 18 x 1	
*	*	*	*	*	*					M 18 x 1.5	
*										M 18 x 2	
*	*	*	*	*	*					M 19 x 1	
*	*	*	*	*	*					M 20 x 1	
*	*	*	*	*	*					M 20 x 1.5	
*	*	*	*	*	*					M 20 x 2	
*	*	*	*	*	*					M 21 x 1	
*	*	*	*	*	*					M 22 x 1	
*	*	*	*	*	*					M 22 x 1.5	
*	*	*	*	*	*					M 22 x 2	
*	*	*	*	*	*					M 23 x 1	
*	*	*	*	*	*					M 24 x 1	
*	*	*	*	*	*					M 24 x 1.5	
*	*	*	*	*	*					M 24 x 2	

● = In stock
 ★ = Allow 7 days for delivery



- Product Finder
- UNC
- UNF
- UNS
- M
- MF**
- G (BSP)
- Rp, R, Rc
- NPT
- NPTF
- STI
- SELF-LOCK
- Smooth
- GT, TD
- Accessories
- Calibration
- Tech. Info

MF



**ISO Metric Fine Thread
DIN 13**

Gage dimensions acc. DIN ISO 1502

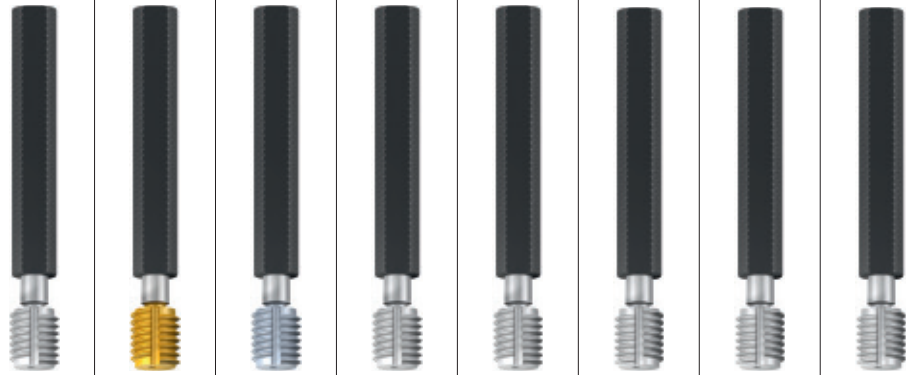

		Class of Fit	6H	6H	6H	4H	6G	6H	4H	6G
		Coating		TIN	CR			LH	LH	LH
		Tool Identification	L0120100	L0125100	L0121100	L0120110	L0120120	L0120150	L0120160	L0120170
		Dimens. ID	G-GUT-LD	G-GUT-LD TIN	G-GUT-LD CR	G-GUT-LD	G-GUT-LD	G-GUT-LD LH	G-GUT-LD LH	G-GUT-LD LH
ϕd_1 mm	P mm									
M 25	x 1	.0456	★			★	★	★	★	★
M 25	x 1.5	.0458	★			★	★	★	★	★
M 25	x 2	.0459	★			★	★	★	★	★
M 26	x 1	.0462	★			★	★	★	★	★
M 26	x 1.5	.0464	★			★	★	★	★	★
M 26	x 2	.0465	★			★	★	★	★	★
M 27	x 1	.0468	★			★	★	★	★	★
M 27	x 1.5	.0470	★			★	★	★	★	★
M 27	x 2	.0471	★			★	★	★	★	★
M 28	x 1	.0474	★			★	★	★	★	★
M 28	x 1.5	.0476	★			★	★	★	★	★
M 28	x 2	.0477	★			★	★	★	★	★
M 30	x 1	.0488	★			★	★	★	★	★
M 30	x 1.5	.0490	★			★	★	★	★	★
M 30	x 2	.0491	★			★	★	★	★	★
M 30	x 3	.0492	★			★	★	★	★	★
M 32	x 1	.0502	★			★	★	★	★	★
M 32	x 1.5	.0504	★			★	★	★	★	★
M 32	x 2	.0505	★			★	★	★	★	★
M 33	x 1	.0509	★			★	★	★	★	★
M 33	x 1.5	.0511	★			★	★	★	★	★
M 33	x 2	.0512	★			★	★	★	★	★
M 33	x 3	.0513	★			★	★	★	★	★
M 34	x 1	.0516	★			★	★	★	★	★
M 34	x 1.5	.0518	★			★	★	★	★	★
M 34	x 2	.0519	★			★	★	★	★	★
M 35	x 1	.0523	★			★	★	★	★	★
M 35	x 1.5	.0525	★			★	★	★	★	★
M 35	x 2	.0526	★			★	★	★	★	★
M 36	x 1	.0530	★			★	★	★	★	★
M 36	x 1.5	.0532	★			★	★	★	★	★
M 36	x 2	.0533	★			★	★	★	★	★
M 36	x 3	.0534	★			★	★	★	★	★
M 38	x 1	.0544	★			★	★	★	★	★
M 38	x 1.5	.0546	★			★	★	★	★	★
M 38	x 2	.0547	★			★	★	★	★	★
M 39	x 1	.0551	★			★	★	★	★	★
M 39	x 1.5	.0553	★			★	★	★	★	★
M 39	x 2	.0554	★			★	★	★	★	★
M 39	x 3	.0555	★			★	★	★	★	★
M 40	x 1	.0558	★			★	★	★	★	★
M 40	x 1.5	.0560	★			★	★	★	★	★
M 40	x 2	.0561	★			★	★	★	★	★
M 40	x 3	.0562	★			★	★	★	★	★
M 42	x 1	.0572	★			★	★	★	★	★
M 42	x 1.5	.0574	★			★	★	★	★	★
M 42	x 2	.0575	★			★	★	★	★	★
M 42	x 3	.0576	★			★	★	★	★	★
M 45	x 1	.0593	★			★	★	★	★	★
M 45	x 1.5	.0595	★			★	★	★	★	★
M 45	x 2	.0596	★			★	★	★	★	★

Product Finder

UNC

UNF

UNS

M

MF

G (BSP)

Rp, R, Rc

NPT

NPTF

STI

SELF-LOCK

Smooth

GT, TD

Accessories

Calibration

Tech. Info

										Class of Fit Coating	
6H	4H	6G	6H LH	4H LH	6G LH					Nominal Size ø d ₁	P mm
L0140100 G-AUS-LD	L0140110 G-AUS-LD	L0140120 G-AUS-LD	L0140150 G-AUS-LD LH	L0140160 G-AUS-LD LH	L0140170 G-AUS-LD LH						
*	*	*	*	*	*					M 25 x 1	
*	*	*	*	*	*					M 25 x 1.5	
*	*	*	*	*	*					M 25 x 2	
*	*	*	*	*	*					M 26 x 1	
*	*	*	*	*	*					M 26 x 1.5	
*	*	*	*	*	*					M 26 x 2	
*	*	*	*	*	*					M 27 x 1	
*	*	*	*	*	*					M 27 x 1.5	
*	*	*	*	*	*					M 27 x 2	
*	*	*	*	*	*					M 28 x 1	
*	*	*	*	*	*					M 28 x 1.5	
*	*	*	*	*	*					M 28 x 2	
*	*	*	*	*	*					M 30 x 1	
*	*	*	*	*	*					M 30 x 1.5	
*	*	*	*	*	*					M 30 x 2	
*	*	*	*	*	*					M 30 x 3	
*	*	*	*	*	*					M 32 x 1	
*	*	*	*	*	*					M 32 x 1.5	
*	*	*	*	*	*					M 32 x 2	
*	*	*	*	*	*					M 33 x 1	
*	*	*	*	*	*					M 33 x 1.5	
*	*	*	*	*	*					M 33 x 2	
*	*	*	*	*	*					M 33 x 3	
*	*	*	*	*	*					M 34 x 1	
*	*	*	*	*	*					M 34 x 1.5	
*	*	*	*	*	*					M 34 x 2	
*	*	*	*	*	*					M 35 x 1	
*	*	*	*	*	*					M 35 x 1.5	
*	*	*	*	*	*					M 35 x 2	
*	*	*	*	*	*					M 36 x 1	
*	*	*	*	*	*					M 36 x 1.5	
*	*	*	*	*	*					M 36 x 2	
*	*	*	*	*	*					M 36 x 3	
*	*	*	*	*	*					M 38 x 1	
*	*	*	*	*	*					M 38 x 1.5	
*	*	*	*	*	*					M 38 x 2	
*	*	*	*	*	*					M 39 x 1	
*	*	*	*	*	*					M 39 x 1.5	
*	*	*	*	*	*					M 39 x 2	
*	*	*	*	*	*					M 39 x 3	
*	*	*	*	*	*					M 40 x 1	
*	*	*	*	*	*					M 40 x 1.5	
*	*	*	*	*	*					M 40 x 2	
*	*	*	*	*	*					M 40 x 3	
*	*	*	*	*	*					M 42 x 1	
*	*	*	*	*	*					M 42 x 1.5	
*	*	*	*	*	*					M 42 x 2	
*	*	*	*	*	*					M 42 x 3	
*	*	*	*	*	*					M 45 x 1	
*	*	*	*	*	*					M 45 x 1.5	
*	*	*	*	*	*					M 45 x 2	

● = In stock
★ = Allow 7 days for delivery



- Product Finder
- UNC
- UNF
- UNS
- M
- MF**
- G (BSP)
- Rp, R, Rc
- NPT
- NPTF
- STI
- SELF-LOCK
- Smooth
- GT, TD
- Accessories
- Calibration
- Tech. Info

MF



**ISO Metric Fine Thread
DIN 13**

Gage dimensions acc. DIN ISO 1502

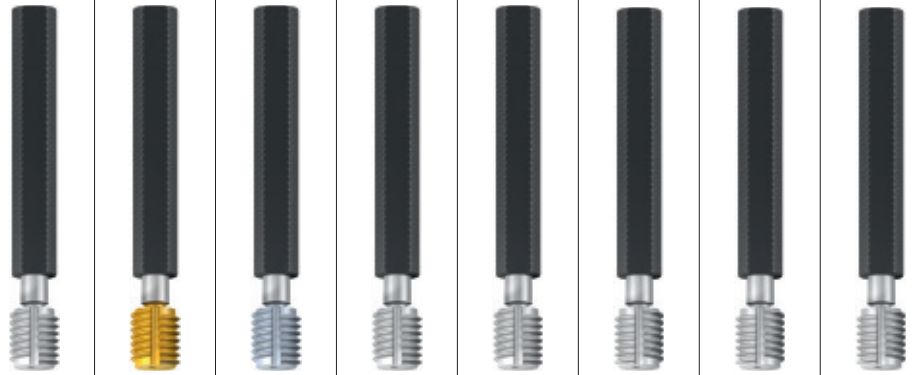

		Class of Fit	6H	6H	6H	4H	6G	6H	4H	6G
		Coating		TIN	CR			LH	LH	LH
		Tool Identification	L0120100	L0125100	L0121100	L0120110	L0120120	L0120150	L0120160	L0120170
		Dimens. ID	G-GUT-LD	G-GUT-LD TIN	G-GUT-LD CR	G-GUT-LD	G-GUT-LD	G-GUT-LD LH	G-GUT-LD LH	G-GUT-LD LH
$\varnothing d_1$ mm	P mm									
M 45	x 3	.0597	★			★	★	★	★	★
M 48	x 1	.0614	★			★	★	★	★	★
M 48	x 1.5	.0616	★			★	★	★	★	★
M 48	x 2	.0617	★			★	★	★	★	★
M 48	x 3	.0618	★			★	★	★	★	★
M 50	x 1	.0628	★			★	★	★	★	★
M 50	x 1.5	.0630	★			★	★	★	★	★
M 50	x 2	.0631	★			★	★	★	★	★
M 50	x 3	.0632	★			★	★	★	★	★
M 52	x 1	.0642	★			★	★	★	★	★
M 52	x 1.5	.0644	★			★	★	★	★	★
M 52	x 2	.0645	★			★	★	★	★	★
M 52	x 3	.0646	★			★	★	★	★	★
M 55	x 1	.0653	★			★	★	★	★	★
M 55	x 1.5	.0654	★			★	★	★	★	★
M 55	x 2	.0655	★			★	★	★	★	★
M 55	x 3	.0656	★			★	★	★	★	★
M 56	x 1	.0658	★			★	★	★	★	★
M 56	x 1.5	.0659	★			★	★	★	★	★
M 56	x 2	.0660	★			★	★	★	★	★
M 56	x 3	.0661	★			★	★	★	★	★
M 58	x 1	.0663	★			★	★	★	★	★
M 58	x 1.5	.0664	★			★	★	★	★	★
M 58	x 2	.0665	★			★	★	★	★	★
M 58	x 3	.0666	★			★	★	★	★	★
M 60	x 1	.0668	★			★	★	★	★	★
M 60	x 1.5	.0669	★			★	★	★	★	★
M 60	x 2	.0670	★			★	★	★	★	★
M 60	x 3	.0671	★			★	★	★	★	★
M 62	x 1	.0673	★			★	★	★	★	★
M 62	x 1.5	.0674	★			★	★	★	★	★
M 62	x 2	.0675	★			★	★	★	★	★
M 62	x 3	.0676	★			★	★	★	★	★
M 64	x 1	.0678	★			★	★	★	★	★
M 64	x 1.5	.0679	★			★	★	★	★	★
M 64	x 2	.0680	★			★	★	★	★	★
M 64	x 3	.0681	★			★	★	★	★	★
M 65	x 1	.0683	★			★	★	★	★	★
M 65	x 1.5	.0684	★			★	★	★	★	★
M 65	x 2	.0685	★			★	★	★	★	★
M 65	x 3	.0686	★			★	★	★	★	★
M 68	x 1	.0688	★			★	★	★	★	★
M 68	x 1.5	.0689	★			★	★	★	★	★
M 68	x 2	.0690	★			★	★	★	★	★
M 68	x 3	.0691	★			★	★	★	★	★
M 70	x 1	.0693	★			★	★	★	★	★
M 70	x 1.5	.0694	★			★	★	★	★	★
M 70	x 2	.0695	★			★	★	★	★	★
M 70	x 3	.0696	★			★	★	★	★	★
M 72	x 1	.0699	★			★	★	★	★	★
M 72	x 1.5	.0700	★			★	★	★	★	★

Product Finder

UNC

UNF

UNS

M

MF

G (BSP)

Rp, R, Rc

NPT

NPTF

STI

SELF-LOCK

Smooth

GT, TD

Accessories

Calibration

Tech. Info

										Class of Fit Coating	
6H	4H	6G	6H LH	4H LH	6G LH					Nominal Size ø d ₁	P mm
L0140100 G-AUS-LD	L0140110 G-AUS-LD	L0140120 G-AUS-LD	L0140150 G-AUS-LD LH	L0140160 G-AUS-LD LH	L0140170 G-AUS-LD LH						
*	*	*	*	*	*					M 45	x 3
*	*	*	*	*	*					M 48	x 1
*	*	*	*	*	*					M 48	x 1.5
*	*	*	*	*	*					M 48	x 2
*	*	*	*	*	*					M 48	x 3
*	*	*	*	*	*					M 50	x 1
*	*	*	*	*	*					M 50	x 1.5
*	*	*	*	*	*					M 50	x 2
*	*	*	*	*	*					M 50	x 3
*	*	*	*	*	*					M 52	x 1
*	*	*	*	*	*					M 52	x 1.5
*	*	*	*	*	*					M 52	x 2
*	*	*	*	*	*					M 52	x 3
*	*	*	*	*	*					M 55	x 1
*	*	*	*	*	*					M 55	x 1.5
*	*	*	*	*	*					M 55	x 2
*	*	*	*	*	*					M 55	x 3
*	*	*	*	*	*					M 56	x 1
*	*	*	*	*	*					M 56	x 1.5
*	*	*	*	*	*					M 56	x 2
*	*	*	*	*	*					M 56	x 3
*	*	*	*	*	*					M 58	x 1
*	*	*	*	*	*					M 58	x 1.5
*	*	*	*	*	*					M 58	x 2
*	*	*	*	*	*					M 58	x 3
*	*	*	*	*	*					M 60	x 1
*	*	*	*	*	*					M 60	x 1.5
*	*	*	*	*	*					M 60	x 2
*	*	*	*	*	*					M 60	x 3
*	*	*	*	*	*					M 62	x 1
*	*	*	*	*	*					M 62	x 1.5
*	*	*	*	*	*					M 62	x 2
*	*	*	*	*	*					M 62	x 3
*	*	*	*	*	*					M 64	x 1
*	*	*	*	*	*					M 64	x 1.5
*	*	*	*	*	*					M 64	x 2
*	*	*	*	*	*					M 64	x 3
*	*	*	*	*	*					M 65	x 1
*	*	*	*	*	*					M 65	x 1.5
*	*	*	*	*	*					M 65	x 2
*	*	*	*	*	*					M 65	x 3
*	*	*	*	*	*					M 68	x 1
*	*	*	*	*	*					M 68	x 1.5
*	*	*	*	*	*					M 68	x 2
*	*	*	*	*	*					M 68	x 3
*	*	*	*	*	*					M 70	x 1
*	*	*	*	*	*					M 70	x 1.5
*	*	*	*	*	*					M 70	x 2
*	*	*	*	*	*					M 70	x 3
*	*	*	*	*	*					M 72	x 1
*	*	*	*	*	*					M 72	x 1.5

● = In stock
★ = Allow 7 days for delivery



- Product Finder
- UNC
- UNF
- UNS
- M
- MF**
- G (BSP)
- Rp, R, Rc
- NPT
- NPTF
- STI
- SELF-LOCK
- Smooth
- GT, TD
- Accessories
- Calibration
- Tech. Info

MF



**ISO Metric Fine Thread
DIN 13**

Gage dimensions acc. DIN ISO 1502

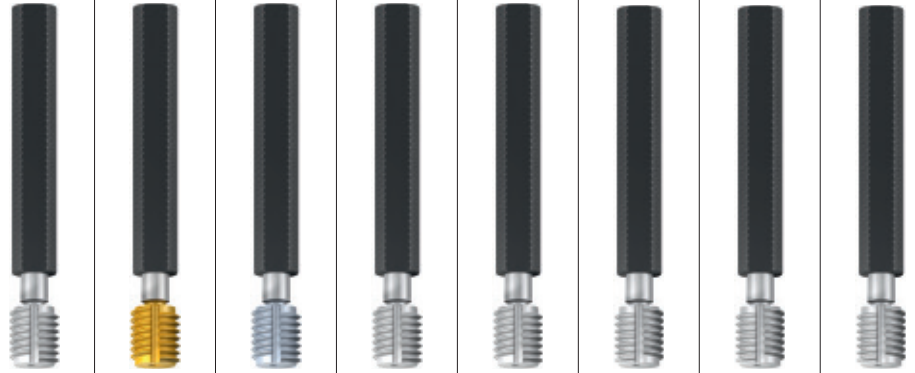

		Class of Fit	6H	6H	6H	4H	6G	6H	4H	6G
		Coating		TIN	CR			LH	LH	LH
		Tool Identification	L0120100	L0125100	L0121100	L0120110	L0120120	L0120150	L0120160	L0120170
		Dimens. ID	G-GUT-LD	G-GUT-LD TIN	G-GUT-LD CR	G-GUT-LD	G-GUT-LD	G-GUT-LD LH	G-GUT-LD LH	G-GUT-LD LH
$\varnothing d_1$ mm	P mm									
M 72	x 2	.0701	★			★	★	★	★	★
M 72	x 3	.0702	★			★	★	★	★	★
M 75	x 1	.0705	★			★	★	★	★	★
M 75	x 1.5	.0706	★			★	★	★	★	★
M 75	x 2	.0707	★			★	★	★	★	★
M 75	x 3	.0708	★			★	★	★	★	★
M 76	x 1	.0711	★			★	★	★	★	★
M 76	x 1.5	.0712	★			★	★	★	★	★
M 76	x 2	.0713	★			★	★	★	★	★
M 76	x 3	.0714	★			★	★	★	★	★
M 78	x 1	.0717	★			★	★	★	★	★
M 78	x 1.5	.0718	★			★	★	★	★	★
M 78	x 2	.0719	★			★	★	★	★	★
M 80	x 1	.0723	★			★	★	★	★	★
M 80	x 1.5	.0724	★			★	★	★	★	★
M 80	x 2	.0725	★			★	★	★	★	★
M 80	x 3	.0726	★			★	★	★	★	★
M 82	x 1.5	.0729	★			★	★	★	★	★
M 82	x 2	.0730	★			★	★	★	★	★
M 85	x 1.5	.0734	★			★	★	★	★	★
M 85	x 2	.0735	★			★	★	★	★	★
M 85	x 3	.0736	★			★	★	★	★	★
M 88	x 1.5	.0739	★			★	★	★	★	★
M 88	x 2	.0740	★			★	★	★	★	★
M 90	x 1.5	.0744	★			★	★	★	★	★
M 90	x 2	.0745	★			★	★	★	★	★
M 90	x 3	.0746	★			★	★	★	★	★
M 92	x 1.5	.0749	★			★	★	★	★	★
M 92	x 2	.0750	★			★	★	★	★	★
M 95	x 1.5	.0754	★			★	★	★	★	★
M 95	x 2	.0755	★			★	★	★	★	★
M 95	x 3	.0756	★			★	★	★	★	★
M 98	x 1.5	.0759	★			★	★	★	★	★
M 98	x 2	.0760	★			★	★	★	★	★
M 100	x 1.5	.0764	★			★	★	★	★	★
M 100	x 2	.0765	★			★	★	★	★	★
M 100	x 3	.0766	★			★	★	★	★	★

← M45 x 3 - M72 x 1.5

Short Form Certificate of Accuracy is furnished free with each gage,
Long Form Certificates are available upon request

Product Finder

- UNC
- UNF
- UNS
- M
- MF**
- G (BSP)
- Rp, R, Rc
- NPT
- NPTF
- STI
- SELF-LOCK
- Smooth
- GT, TD
- Accessories
- Calibration
- Tech. Info

6H	4H	6G	6H	4H	6G						
			LH	LH	LH						Class of Fit Coating
L0140100 G-AUS-LD	L0140110 G-AUS-LD	L0140120 G-AUS-LD	L0140150 G-AUS-LD LH	L0140160 G-AUS-LD LH	L0140170 G-AUS-LD LH						Nominal Size ϕd_1
											P mm
★	★	★	★	★	★						M 72 x 2
★	★	★	★	★	★						M 72 x 3
★	★	★	★	★	★						M 75 x 1
★	★	★	★	★	★						M 75 x 1.5
★	★	★	★	★	★						M 75 x 2
★	★	★	★	★	★						M 75 x 3
★	★	★	★	★	★						M 76 x 1
★	★	★	★	★	★						M 76 x 1.5
★	★	★	★	★	★						M 76 x 2
★	★	★	★	★	★						M 76 x 3
★	★	★	★	★	★						M 78 x 1
★	★	★	★	★	★						M 78 x 1.5
★	★	★	★	★	★						M 78 x 2
★	★	★	★	★	★						M 80 x 1
★	★	★	★	★	★						M 80 x 1.5
★	★	★	★	★	★						M 80 x 2
★	★	★	★	★	★						M 80 x 3
★	★	★	★	★	★						M 82 x 1.5
★	★	★	★	★	★						M 82 x 2
★	★	★	★	★	★						M 85 x 1.5
★	★	★	★	★	★						M 85 x 2
★	★	★	★	★	★						M 85 x 3
★	★	★	★	★	★						M 88 x 1.5
★	★	★	★	★	★						M 88 x 2
★	★	★	★	★	★						M 90 x 1.5
★	★	★	★	★	★						M 90 x 2
★	★	★	★	★	★						M 90 x 3
★	★	★	★	★	★						M 92 x 1.5
★	★	★	★	★	★						M 92 x 2
★	★	★	★	★	★						M 95 x 1.5
★	★	★	★	★	★						M 95 x 2
★	★	★	★	★	★						M 95 x 3
★	★	★	★	★	★						M 98 x 1.5
★	★	★	★	★	★						M 98 x 2
★	★	★	★	★	★						M 100 x 1.5
★	★	★	★	★	★						M 100 x 2
★	★	★	★	★	★						M 100 x 3



Thread ring gages GO/NO-GO upon request

● = In stock
★ = Allow 7 days for delivery



- Product Finder
- UNC
- UNF
- UNS
- M
- MF
- G (BSP)**
- Rp, R, Rc
- NPT
- NPTF
- STI
- SELF-LOCK
- Smooth
- GT, TD
- Accessories
- Calibration
- Tech. Info

G (BSP)



**Whitworth Pipe Thread
DIN EN ISO 228**

Gage dimensions acc. DIN EN ISO 228-2

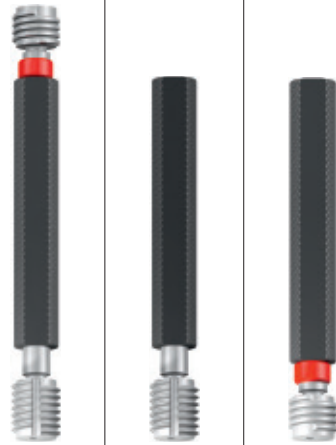

Nominal Size ø d ₁	ø d ₁ mm	T.P.I.	Tool Identification Dimens. ID	L0100100	L0120100	L0140100			
				G-GR-LD	G-GUT-LD	G-AUS-LD			
G 1/16	7.72	28	.4034	★	★	★			
G 1/8	9.73	28	.4035	★	★	★			
G 1/4	13.16	19	.4036	★	★	★			
G 3/8	16.66	19	.4037	★	★	★			
G 1/2	20.96	14	.4038	★	★	★			
G 5/8	22.91	14	.4039	★	★	★			
G 3/4	26.44	14	.4040	★	★	★			
G 7/8	30.20	14	.4041	★	★	★			
G 1	33.25	11	.4042	★	★	★			
G 1 1/8	37.90	11	.4043	★	★	★			
G 1 1/4	41.91	11	.4044		★	★			
G 1 3/8	44.32	11	.4045		★	★			
G 1 1/2	47.80	11	.4046		★	★			
G 1 5/8	52.00	11	.4047						
G 1 3/4	53.75	11	.4048		★	★			
G 2	59.61	11	.4050		★	★			

> G 1 1/8 available only as separate plug gages (G-GUT-LD, G-AUS-LD)

**Short Form Certificate of Accuracy is furnished free with each gage,
Long Form Certificates are available upon request**



Thread ring gages GO/NO-GO upon request

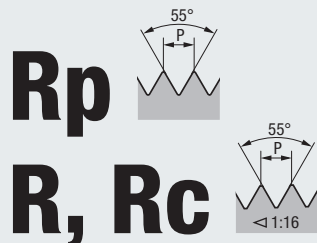

Rp
R, Rc
Tapered Whitworth Pipe Thread,
DIN EN ISO 10226-1, DIN EN ISO 10226-2
and ISO 7-1

Where pressure-tight joints are made on the threads,
taper 1:16

Gage system acc. DIN EN 10226-3, ISO 7-2

**Work
Gages**

**Inspection
Thread Gages**

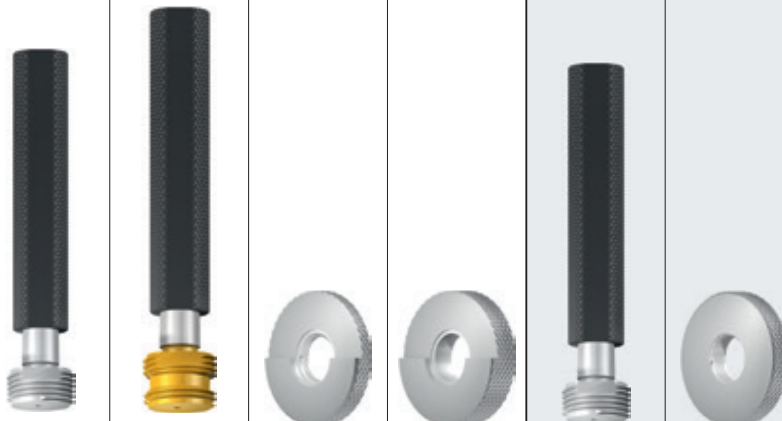

- Product Finder
- UNC
- UNF
- UNS
- M
- MF
- G (BSP)
- Rp, R, Rc**
- NPT
- NPTF
- STI
- SELF-LOCK
- Smooth
- GT, TD
- Accessories
- Calibration
- Tech. Info

				Gage no.		1	2 1)	3	4	5	6
				Tool Identification		L1800101	L1815101	L1850501	L1860501	L1830501	L1870101
				Dimens. ID		Keg. G-GR-LD	Keg. G-GR-LD Aussp. TIN	Zyl. G-GR-LR	Keg. G-GR-LR (glatt)	Keg. G-Prüfdorn	Zyl. G-Prüftring
Nominal Size $\varnothing d_1$	$\varnothing d_1$ mm	T.P.I.									
R 1/16	7.72	28	.4068	★	★	★	★	★	★	★	★
R 1/8	9.73	28	.4069	★	★	★	★	★	★	★	★
R 1/4	13.16	19	.4070	★	★	★	★	★	★	★	★
R 3/8	16.66	19	.4071	★	★	★	★	★	★	★	★
R 1/2	20.96	14	.4072	★	★	★	★	★	★	★	★
R 3/4	26.44	14	.4073	★	★	★	★	★	★	★	★
R 1	32.25	11	.4074	★	★	★	★	★	★	★	★
R 1 1/4	41.91	11	.4075	★	★	★	★	★	★	★	★
R 1 1/2	47.80	11	.4076	★	★	★	★	★	★	★	★
R 2	59.61	11	.4077	★	★	★	★	★	★	★	★
R 2 1/2	75.18	11	.4078	★	★	★	★	★	★	★	★
R 3	87.88	11	.4079	★	★	★	★	★	★	★	★
R 4	113.03	11	.4080	★	★	★	★	★	★	★	★

1) The thread plug gage no. 2 is exposed to strong wear due to its recess, and is therefore TIN-coated

Short Form Certificate of Accuracy is furnished free with each gage,
Long Form Certificates are available upon request

The new gage system acc. DIN EN 10226-3, ISO 7-2

The standardization has been undertaken with the aim of providing a worldwide accepted gage system for the tapered external thread R, the cylindrical internal thread Rp and the tapered internal thread Rc acc. ISO 7.

Previous standards, e.g. the German standards DIN 2999-2 to -6, the British standard BS 21, the French standard NF-E 03-165 and the Italian standard UNI ISO 7-2:1984 do not apply anymore.



- Product Finder
- UNC
- UNF
- UNS
- M
- MF
- G (BSP)
- Rp, R, Rc
- NPT**
- NPTF
- STI
- SELF-LOCK
- Smooth
- GT, TD
- Accessories
- Calibration
- Tech. Info

NPT



**American Tapered Pipe Thread,
ANSI/ASME B1.20.1**

For threads **with dryseal material**,
taper 1:16

Gage system sim. ANSI/ASME B1.20.1

"3-Step" Design



Nominal Size ø d ₁	T.P.I.	Tool Identification	L0500100		
		Dimens. ID	G-GR-LD (L ₁) NPT		
1/16	27	.5763	●		
1/8	27	.5764	●		
1/4	18	.5765	●		
3/8	18	.5766	●		
1/2	14	.5767	●		
3/4	14	.5768	●		
1	11 1/2	.5769	●		
1 1/4	11 1/2	.5770	★		
1 1/2	11 1/2	.5771	★		
2	11 1/2	.5772	★		

Short Form Certificate of Accuracy is furnished free with each gage,
Long Form Certificates are available upon request



Thread ring gages GO/NO-GO upon request

NPTF

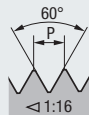

**American Tapered Pipe Thread,
ANSI/ASME B1.20.3**

For threads **without dryseal material**,
taper 1:16

Gage system NPTF-1 acc. ASME B1.20.5

"3-Step" Design



Nominal Size $\varnothing d_1$	T.P.I.	Tool Identification			
		Dimens. ID	L0520100 G-GR-LD (L ₁ + L ₃) NPTF	L0500100 G-GR-LD (L ₁) NPTF	L0510100 G-GR-LD (L ₃) NPTF
1/16	27	.5782	●		
1/8	27	.5783	●		
1/4	18	.5784	●		
3/8	18	.5785	●		
1/2	14	.5786	●		
3/4	14	.5787	●		
1	11 1/2	.5788	★		
1 1/4	11 1/2	.5789		★	★
1 1/2	11 1/2	.5790		★	★
2	11 1/2	.5791		★	★

> $\varnothing 1"$ available only as separate plug gages (G-GR-LD (L₁), G-GR-LD (L₃))

Short Form Certificate of Accuracy is furnished free with each gage,
Long Form Certificates are available upon request

Gage system NPTF-2 acc. ASME B1.20.5

for NPTF internal thread

- L₁ thread plug gage ("4-step" design)
- L₃ thread plug gage ("4-step" design)
- Plug gage "Crest Check" ("6-step"), for checking the thread crest on the minor diameter
- Plug gage "Root Check" ("6-step"), for checking the thread root on the major diameter

for NPTF external thread

- L₁ thread ring gage ("4-step" design)
- L₂ thread ring gage ("4-step" design)
- Ring gage "Crest Check" ("6-step"), for checking the thread crest on the major diameter
- Ring gage "Root Check" ("6-step"), for checking the thread root on the minor diameter

Thread gages GO/NO-GO for gage system NPTF-2 upon request



Thread ring gages GO/NO-GO upon request

● = In stock
★ = Allow 7 days for delivery

- Product Finder
- UNC
- UNF
- UNS
- M
- MF
- G (BSP)
- Rp, R, Rc
- NPT
- NPTF**
- STI
- SELF-LOCK
- Smooth
- GT, TD
- Accessories
- Calibration
- Tech. Info



- Product Finder
- UNC
- UNF
- UNS
- M
- MF
- G (BSP)
- Rp, R, Rc
- NPT
- NPTF
- STI**
- SELF-LOCK
- Smooth
- GT, TD
- Accessories
- Calibration
- Tech. Info

STI-M

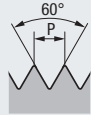

**ISO Metric Coarse Thread
DIN 8140-2**

For wire thread inserts



Gage dimensions acc. DIN ISO 1502

		Class of Fit	6H mod.				
		Coating					
		Tool Identification	L0100100				
		Dimens. ID	G-GR-LD				
Nominal Size ø d ₁	P mm	Dimens. ID					
STI-M 2.5	0.45	.0965	★				
STI-M 3	0.5	.0966	★				
STI-M 3.5	0.6	.0967	★				
STI-M 4	0.7	.0968	★				
STI-M 5	0.8	.0970	★				
STI-M 6	1	.0971	★				
STI-M 8	1.25	.0973	★				
STI-M 10	1.5	.0975	★				
STI-M 12	1.75	.0977	★				
STI-M 14	2	.0978	★				
STI-M 16	2	.0979	★				
STI-M 18	2.5	.0980	★				
STI-M 20	2.5	.0981	★				

STI thread plug gages for UNC, UNF thread and ISO Metric fine thread upon request

**Short Form Certificate of Accuracy is furnished free with each gage,
Long Form Certificates are available upon request**



LK-UNC

Unified SELF-LOCK Coarse Thread
EMUGE Standard

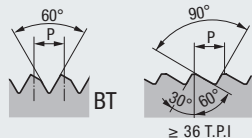

Gage dimensions acc. EMUGE standard

Nominal Size ø d ₁	T.P.I.	Tool Identification				
		Dimens. ID				
			L0100100			
			G-GR-LD			
No. 4	40	.5656	●			
No. 6	32	.5668	●			
No. 8	32	.5659	●			
No. 10	24	.5660	●			
No. 12	24	.5661	●			
1/4	20	.5662	●			
5/16	18	.5663	●			
3/8	16	.5664	●			
7/16	14	.5665	●			
1/2	13	.5666	●			
9/16	12	.5667	●			
5/8	11	.5668	●			
3/4	10	.5669	●			
7/8	9	.5670	●			
1	8	.5671	●			

Short Form Certificate of Accuracy is furnished free with each gage,
Long Form Certificates are available upon request

The gaging of the EMUGE SELF-LOCK thread

We recommend using our two-piece gage system which corresponds to the usual combination of GO and NO-GO gage and is perfectly sufficient for the gaging of the thread, provided that the LK threads were produced with our true-to-profile EMUGE taps.

There is no generally applicable standard (e.g. DIN standard) for the EMUGE SELF-LOCK thread, so other manufacturers may use different limit sizes for their threads. For this reason, we recommend gaging EMUGE SELF-LOCK threads exclusively with EMUGE SELF-LOCK gages.

The gaging of the saw-tooth profile works on the same principle, with the only difference that both the GO and the NO-GO plug gage have to be used in the correct direction.

If chasers or thread milling cutters are used, we recommend using an additional EMUGE HRPG gage. This gage serves to check the lower ramp point or possible ramp angle errors.

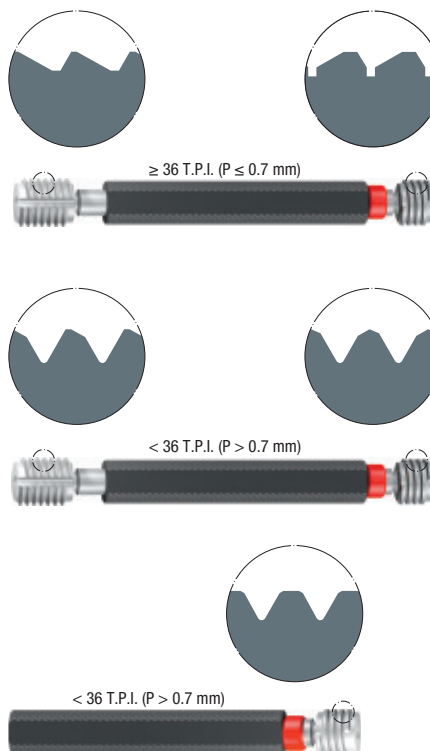

- Product Finder
- UNC
- UNF
- UNS
- M
- MF
- G (BSP)
- Rp, R, Rc
- NPT
- NPTF
- STI
- SELF-LOCK**
- Smooth
- GT, TD
- Accessories
- Calibration
- Tech. Info

● = In stock
★ = Allow 7 days for delivery

- Product Finder
- UNC
- UNF
- UNS
- M
- MF
- G (BSP)
- Rp, R, Rc
- NPT
- NPTF
- STI
- SELF-LOCK**
- Smooth
- GT, TD
- Accessories
- Calibration
- Tech. Info

LK-UNF

Unified SELF-LOCK Fine Thread
EMUGE Standard

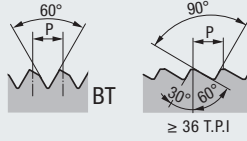

Gage dimensions acc. EMUGE standard

Nominal Size $\varnothing d_1$	T.P.I.	Tool Identification	
		Dimens. ID	L0100100 G-GR-LD
No. 4	48	.5707	●
No. 6	40	.5709	●
No. 8	36	.5710	●
No. 10	32	.5711	●
1/4	28	.5713	●
5/16	24	.5714	●
3/8	24	.5715	●
7/16	20	.5716	●
1/2	20	.5717	●
9/16	18	.5718	●
5/8	18	.5719	●
3/4	16	.5720	●

Short Form Certificate of Accuracy is furnished free with each gage,
Long Form Certificates are available upon request



LK-M

Metric SELF-LOCK Coarse Thread
EMUGE Standard

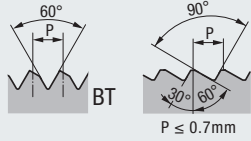

Gage dimensions acc. EMUGE standard

Nominal Size ø d ₁	P mm	Tool Identification				
		Dimens. ID				
			L0100100			
			G-GR-LD			
LK-M 3	0.5	.1046	●			
LK-M 4	0.7	.1048	●			
LK-M 5	0.8	.1050	●			
LK-M 6	1	.1052	●			
LK-M 8	1.25	.1054	●			
LK-M 10	1.5	.1056	●			
LK-M 12	1.75	.1058	●			
LK-M 14	2	.1059	●			
LK-M 16	2	.1060	●			
LK-M 20	2.5	.1062	●			
LK-M 24	3	.1064	●			

Short Form Certificate of Accuracy is furnished free with each gage,
Long Form Certificates are available upon request

Product Finder

UNC

UNF

UNS

M

MF

G (BSP)

Rp, R, Rc

NPT

NPTF

STI

SELF-LOCK

Smooth

GT, TD

Accessories

Calibration

Tech. Info



- Product Finder
- UNC
- UNF
- UNS
- M
- MF
- G (BSP)
- Rp, R, Rc
- NPT
- NPTF
- STI
- SELF-LOCK

Gage dimensions acc. DIN EN ISO 1938-1



- Smooth
- GT, TD
- Accessories
- Calibration
- Tech. Info

Nominal Diameter mm	Class of Fit		H7	H7	H7
	Tool Identification		L14000H7	L14200H7	L14400H7
	Dimens. ID		GR-LD DIN 2245 Form Z	GUT-LD DIN 2246 Form ZG	AUS-LD DIN 2247 Form ZA
3	.0030		*		
3.5	.0035		*		
4	.0040		*		
4.5	.0045		*		
5	.0050		*		
5.5	.0055		*		
6	.0060		*		
7	.0070		*		
8	.0080		*		
9	.0090		*		
10	.0100		*		
11	.0110		*		
12	.0120		*		
13	.0130		*		
14	.0140		*		
15	.0150		*		
16	.0160		*		
17	.0170		*		
18	.0180		*		
19	.0190		*		
20	.0200		*		
21	.0210		*		
22	.0220		*		
23	.0230		*		
24	.0240		*		
25	.0250		*		
26	.0260		*		
27	.0270		*		
28	.0280		*		
30	.0300		*		
32	.0320		*		
33	.0330		*		
34	.0340		*		
35	.0350		*		
36	.0360		*		
37	.0370		*		
40	.0400		*		
44	.0440		*		
45	.0450		*		
46	.0460		*		
47	.0470		*		
48	.0480		*		
50	.0500		*		
52	.0520		*		
55	.0550		*		
58	.0580		*		
60	.0600		*		
62	.0620		*		
65	.0650		*		
68	.0680			*	*
70	.0700			*	*
72	.0720			*	*
75	.0750			*	*
78	.0780			*	*
80	.0800			*	*

> ø 65 mm available only as separate plug gages (GUT-LD, AUS-LD)

Further classes of fit according to DIN ISO 286-2 can be produced upon request

M



For Cut Threads

ISO Metric Coarse Thread
DIN 13



Gage dimensions acc. DIN ISO 1502

			Class of Fit		6H	
Metric Threads	Minor dia. of the internal thread mm		Tool Identification		L0160100	
	min.	max.	Dimens. ID	Glatt-GR-LD		
M 3	2.459	2.599	.0030	●		
M 3.5	2.850	3.010	.0035			
M 4	3.242	3.422	.0040	●		
M 4.5	3.688	3.878	.0045			
M 5	4.134	4.334	.0050	●		
M 6	4.917	5.153	.0060	●		
M 7	5.917	6.153	.0070	●		
M 8	6.647	6.912	.0080	●		
M 9	7.647	7.912	.0090			
M 10	8.376	8.676	.0100	●		
M 11	9.376	9.676	.0111			
M 12	10.106	10.441	.0112	●		
M 14	11.835	12.210	.0114			
M 16	13.835	14.210	.0116	●		
M 18	15.294	15.744	.0118			
M 20	17.294	17.744	.0120			

M

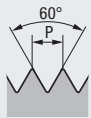

For Cold-Formed Threads

ISO Metric Coarse Thread
DIN 13

Gage dimensions acc. DIN ISO 1502

According to DIN 13-50, in a cold-formed thread the **class of fit** for the pitch diameter is 6H, for the **minor diameter of the internal thread** it is 7H.

			Class of Fit		7H	
Metric Threads	Minor dia. of the internal thread mm		Tool Identification		L0160105	
	min.	max.	Dimens. ID	Glatt-GR-LD		
M 3	2.459	2.639	.0030	●		
M 3.5	2.850	3.050	.0035			
M 4	3.242	3.466	.0040	●		
M 5	4.134	4.384	.0050	●		
M 6	4.917	5.217	.0060	●		
M 7	5.917	6.217	.0070	●		
M 8	6.647	6.982	.0080	●		
M 10	8.376	8.751	.0100	●		
M 12	10.106	10.531	.0112	●		
M 14	11.835	12.310	.0114			
M 16	13.835	14.310	.0116	●		

Short Form Certificate of Accuracy is furnished free with each gage,
Long Form Certificates are available upon request

Further designs upon request

● = In stock
★ = Allow 7 days for delivery

- Product Finder
- UNC
- UNF
- UNS
- M
- MF
- G (BSP)
- Rp, R, Rc
- NPT
- NPTF
- STI
- SELF-LOCK
- Smooth
- GT, TD
- Accessories
- Calibration
- Tech. Info



- Product Finder
- UNC**
- UNF
- UNS
- M
- MF
- G (BSP)
- Rp, R, Rc
- NPT
- NPTF
- STI
- SELF-LOCK
- Smooth
- GT, TD**
- Accessories
- Calibration
- Tech. Info

UNC



**Unified Coarse Thread
ASME B1.1**

Gage dimensions acc. ANSI/ASME B1.2



		Class of Fit		2B	2B	
		Max. Thread Depth		4 x D	2.5 x D	
		Tool Identification		L1010100	L1040100	
Nominal Size $\varnothing d_1$	T.P.I.	Dimens. ID	GT-GR-LD "analog"	TD-Bit-GUT "analog"		
No. 1	64	.5000	*			
No. 2	56	.5001	*			
No. 3	48	.5002	*			
No. 4	40	.5003	*			
No. 5	40	.5004	*		*	
No. 6	32	.5005	*		*	
No. 8	32	.5006	*		*	
No. 10	24	.5007	*		*	
No. 12	24	.5008	*		*	
1/4	20	.5009	*		*	
5/16	18	.5010	*		*	
3/8	16	.5011	*		*	
7/16	14	.5012	*		*	
1/2	13	.5013	*		*	
9/16	12	.5014	*			
5/8	11	.5015	*			
3/4	10	.5016	*			
7/8	9	.5017	*			

Short Form Certificate of Accuracy is furnished free with each gage,
Long Form Certificates are available upon request



Torque limiter for thread depth plug gages GT-GR-LD "analog" available on request

Accessories



Pulling sleeves for exchange of the GO gage body for all versions ▶▶ 464



Hook spanner for tightening the counter nut of GT-GR-LD ▶▶ 464

UNF 
 Unified Fine Thread
 ASME B1.1

Gage dimensions acc. ANSI/ASME B1.2



		Class of Fit		2B	2B
		Max. Thread Depth		4 x D	2.5 x D
		Tool Identification		L1010100	L1040100
Nominal Size $\varnothing d_1$	T.P.I.	Dimens. ID	GT-GR-LD "analog"	TD-Bit-GUT "analog"	
No. 0	80	.5033	*		
No. 1	72	.5034	*		
No. 2	64	.5035	*		
No. 3	56	.5036	*		
No. 4	48	.5037	*		
No. 5	44	.5038	*	*	
No. 6	40	.5039	*	*	
No. 8	36	.5040	*	*	
No. 10	32	.5041	*	*	
No. 12	28	.5042	*	*	
1/4	28	.5043	*	*	
5/16	24	.5044	*	*	
3/8	24	.5045	*	*	
7/16	20	.5046	*	*	
1/2	20	.5047	*	*	
9/16	18	.5048	*		
5/8	18	.5049	*		
3/4	16	.5050	*		
7/8	14	.5051	*		

Short Form Certificate of Accuracy is furnished free with each gage,
 Long Form Certificates are available upon request



Torque limiter for thread depth plug gages GT-GR-LD "analog" available on request

Accessories

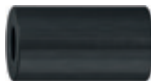

Pulling sleeves for exchange of the GO gage body for all versions ▶▶ 464



Hook spanner for tightening the counter nut of GT-GR-LD ▶▶ 464

- Product Finder
- UNC
- UNF**
- UNS
- M
- MF
- G (BSP)
- Rp, R, Rc
- NPT
- NPTF
- STI
- SELF-LOCK
- Smooth
- GT, TD**
- Accessories
- Calibration
- Tech. Info



● = In stock
 ★ = Allow 7 days for delivery

- Product Finder
- UNC
- UNF
- UNS
- M**
- MF
- G (BSP)
- Rp, R, Rc
- NPT
- NPTF
- STI
- SELF-LOCK
- Smooth
- GT, TD**
- Accessories
- Calibration
- Tech. Info

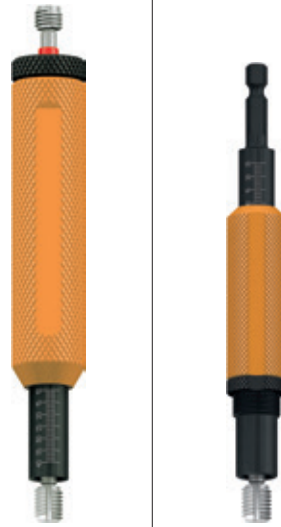
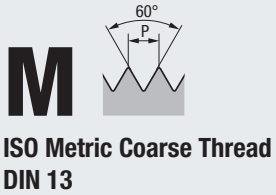



Gage dimensions acc. DIN ISO 1502

		Class of Fit		6H	6H
		Max. Thread Depth		4 x D	2.5 x D
		Tool Identification		L1010100	L1040100
		Dimens. ID		GT-GR-LD "analog"	TD-Bit-GUT "analog"
Nominal Size $\varnothing d_1$	P mm				
M 2	0.4	.0020	*		
M 3	0.5	.0030	*		
M 4	0.7	.0040	*		*
M 5	0.8	.0050	*		*
M 6	1	.0060	*		*
M 8	1.25	.0080	*		*
M 10	1.5	.0100	*		*
M 12	1.75	.0112	*		*
M 14	2	.0114	*		*
M 16	2	.0116	*		
M 18	2.5	.0118	*		
M 20	2.5	.0120	*		
M 22	2.5	.0122	*		
M 24	3	.0124	*		

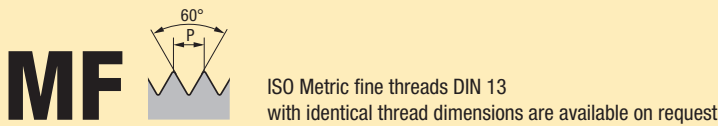
Short Form Certificate of Accuracy is furnished free with each gage,
Long Form Certificates are available upon request



Accessories

- 
Pulling sleeves for exchange of the GO gage body for all versions
▶▶ 464
- 
Hook spanner for tightening the counter nut of GT-GR-LD
▶▶ 464

G (BSP) 
 Whitworth Pipe Thread
 DIN EN ISO 228



Gage dimensions acc. DIN EN ISO 228-1

				Class of Fit			
				Max. Thread Depth			
				Tool Identification			
				Dimens. ID			
Nominal Size $\varnothing d_1$	$\varnothing d_1$ mm	T.P.I.		GT-GR-LD "analog"	TD-Bit-GUT "analog"		
G 1/16	7.72	28	.4034	★	★		
G 1/8	9.73	28	.4035	★	★		
G 1/4	13.16	19	.4036	★	★		
G 3/8	16.66	19	.4037	★			
G 1/2	20.96	14	.4038	★			
G 5/8	22.91	14	.4039	★			

Short Form Certificate of Accuracy is furnished free with each gage,
 Long Form Certificates are available upon request



Accessories

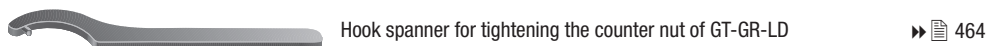
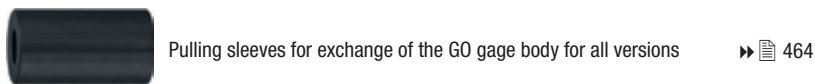

- Product Finder
- UNC
- UNF
- UNS
- M
- MF
- G (BSP)**
- Rp, R, Rc
- NPT
- NPTF
- STI
- SELF-LOCK
- Smooth
- GT, TD**
- Accessories
- Calibration
- Tech. Info



● = In stock
 ★ = Allow 7 days for delivery

- Product Finder
- UNC
- UNF
- UNS
- M
- MF
- G (BSP)
- Rp, R, Rc
- NPT
- NPTF
- STI
- SELF-LOCK
- Smooth
- GT, TD
- Accessories
- Calibration
- Tech. Info

Hexagon bit adapters 1/4" for gaging bodies "GO"

The hexagon bit adapter serves as holder for the gage body "GO" in a power driven unit. It is used for repeatably gaging thread holes with a maximum depth of 4 x D. As a power driven unit such as cordless or pressurized air screwdrivers or drill machines provide the rotation, an effortless and long-term working is possible.



					Max. Thread Depth	4 x D
					Tool Identification	L0091070
Unified Threads	Metric Threads	Whitworth Pipe Threads	Recommended Torque	Dimens. ID		
No.1 - No. 4	M 2 - M 3	–	6 Ncm	.02.5		★
No.5 - No.12	M 4 - M 6	–	8 Ncm	.04		★
1/4 - 3/8	M 8 - M10	G 1/16 - G 1/8	14 Ncm	.05.5		★
7/16 - 1/2	M12 - M14	G 1/4	20 Ncm	.07		★
9/16 - 5/8	M16 - M18	G 3/8	30 Ncm	.09		★
3/4 - 1 1/8	M20 - M30	G 1/2 - G 7/8	40 Ncm	.12		★

Gauging bodies "GO" upon request (not included)

Pulling sleeves

For the exchange of gaging bodies in thread depth plug gages



		Tool Identification	L0091040
Seat Diameter	Dimens. ID		
2.5	.02.5		★
4	.04		★
5.5	.05.5		★
7	.07		★
9	.09		★
12	.12		★

Hook spanner

For tightening the counter nut



					Tool Identification	L0091410
Nominal dia.	Unified Threads	Metric Threads	Whitworth Pipe Threads	Dimens. ID		
≤ 3 mm	No.1 - No. 4	M 2 - M 3	–	.02.5		★
> 3 - 6 mm	No.5 - No.12	M 4 - M 6	–	.04		★
> 6 - 10 mm	1/4 - 3/8	M 8 - M10	G 1/16 - G 1/8	.05.5		★
> 10 - 14 mm	7/16 - 1/2	M12 - M14	G 1/4	.07		★
> 14 - 18 mm	9/16 - 5/8	M16 - M18	G 3/8	.09		★
> 18 - 24 mm	3/4 - 15/16	M20 - M24	G 1/2 - G 5/8	.12		★



EMUGE offers you comprehensive services for the calibration of your gages and measuring tools by our cooperation partner DECOM UGK GmbH, an independent calibration laboratory on the premises of EMUGE-Werk at Lauf.

DECOM UGK GmbH has been a DAkkS-accredited calibration laboratory for length and other geometric quantities (e.g. thread gages, dial gages,

dial gage instruments, dial test indicators, micrometer gages, caliper gages etc.) acc. EN/ISO/IEC 17025 since 1998.

The technical measuring equipment, the personnel and the environmental conditions are subject to surveillance by the DAkkS (German Accreditation Body).



www.decom-ugk.de

Technical Equipment

Reference Standards and Standard Measuring Devices:

The compliance with national and international standards of all measurements commissioned by customers is guaranteed. All necessary standards and standard measuring devices are at our disposal and are regularly recalibrated by calibration laboratories authorized by the WECC.

Traceability of measuring devices to national standards.

An extensive range of equipment is available to conduct inspection monitoring of operating equipment. The measuring devices and measuring equipment are certified to be in compliance with national standards by means of regular in-house calibrations using reference standards and standard measuring devices.

For more information please contact the sales organisation of the company association EMUGE-FRANKEN (www.emuge-franken.com/sales).

Inspection monitoring according to VDI/VDE/DGQ-directive 2618, sheet 4.8 "Ü"

- Cleaning
- Demagnetizing
- Visual inspection for damage
- Rework of minor damages with oil stone and lapping cloth
- Determine marking, if applicable, establish ID number and apply marking
- Tempering (min. 5 hours)
- Visual inspection for correct marking, if applicable colour marking
- Determination of specific values: pitch diameter at the start of the thread on 2 measuring locations off-set by 90°
- Evaluation of measuring results and creation of calibration certificate
- Preservation and single packaging

All necessary data and measuring results will be documented in a calibration certificate.

- Product Finder
- UNC
- UNF
- UNS
- M
- MF
- G (BSP)
- Rp, R, Rc
- NPT
- NPTF
- STI
- SELF-LOCK
- Smooth
- GT, TD
- Accessories
- Calibration**
- Tech. Info



- Product Finder
- UNC
- UNF
- UNS
- M
- MF
- G (BSP)
- Rp, R, Rc
- NPT
- NPTF
- STI
- SELF-LOCK
- Smooth
- GT, TD
- Accessories
- Calibration
- Tech. Info



Technical Information

		Page
6.1	General information	468
6.2	Precision fixed limit thread gages	468
6.3	EMUGE thread gages – Gaging technology to perfection	469
6.4	Thread gages for internal threads and smooth gages for thread minor diameters	470
6.5	Smooth plug gages for drilled holes acc. DIN EN ISO 1938-1	471
6.6	GT Thread depth plug gages	472 - 473
6.7	Gaging of other threads	474 - 475

Product
Finder

UNC

UNF

UNS

M

MF

G (BSP)

Rp, R, Rc

NPT

NPTF

STI

SELF-LOCK

Smooth

GT, TD

Accessories

Calibration

Tech. Info



- Product Finder
- UNC
- UNF
- UNS
- M
- MF
- G (BSP)
- Rp, R, Rc
- NPT
- NPTF
- STI
- SELF-LOCK
- Smooth
- GT, TD
- Accessories
- Calibration
- Tech. Info**

6.1 General information

Gage systems are specified for the respective types of threads for the purpose of securing an unlimited exchangeability of workpiece threads.

The following basic principles apply:

1. The manufacturer must not supply a workpiece thread the actual thread size of which is outside of the specified limits (e.g. pitch diameter or mating pitch diameter).
2. The buyer must not reject a workpiece thread the actual thread size of which is inside of the specified limits (e.g. pitch diameter or mating pitch diameter).

In modern thread production, there are of course other inspection methods also, e.g. measuring with dial-type measuring instruments. Whenever other methods are applied it is important to make sure that the same results are achieved.

In case of doubt, the gages recommended in the respective standard will decide the inspection result of the thread to be examined.

If the inspection work in production is done mainly by measuring, it is still absolutely necessary to perform random sample inspection with the standardized gages. The reference temperature for the gage and workpiece dimensions is 68 °F (20 °C). If inspections are done at other temperatures, the corresponding expansion coefficients have to be taken into account.

6.2 Precision fixed limit thread gages

EMUGE's comprehensive line of thread gages consist of GO/NO-GO plug gages and thread depth plug gages. Gages inspect the pitch diameter and functional thread for internal-threaded components.

Features:

- Exceptionally hardened tool steel and highly accurate
 - Full range of inch, metric sizes in coarse, fine, UNC, UNF, UNS, NPT, NPTF, along with EMUGE SELF-LOCK threads forms
 - Accommodates 2B, 3B, 6H classes of fit
 - Stable thread start for easy insertion
 - Eliminate thread damage in demanding environments
 - Short Form Certificate of Accuracy is furnished free with each gage, Long Form Certificates are available upon request
- Gage certification is performed by accredited calibration service "DECOM UGK GmbH" calibration laboratory



6.3 EMUGE thread gages – Gaging technology to perfection

Product Finder
UNC
UNF
UNS
M
MF
G (BSP)
Rp, R, Rc
NPT
NPTF
STI
SELF-LOCK
Smooth
GT, TD
Accessories
Calibration
Tech. Info

Accommodates **2B, 3B, 6H classes of fit**

Starting from dia. **5.5 mm** a **dirt flute** is provided on the GO side to eliminate thread damage in demanding environments

Exceptionally hardened tool steel and highly accurate

A full range of stocked inch and Metric gages are manufactured to **ANSI B1.2** (Unified screw threads) and **ISO 1502** resp. **ANSI B1.16M** (Metric M series screw threads)

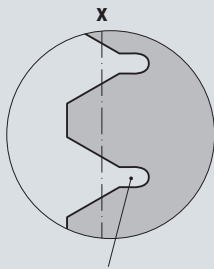

Recessed minor thread diameter of the NO-GO gages for safe function



- Product Finder
- UNC
- UNF
- UNS
- M
- MF
- G (BSP)
- Rp, R, Rc
- NPT
- NPTF
- STI
- SELF-LOCK
- Smooth
- GT, TD
- Accessories
- Calibration
- Tech. Info

6.4 Thread gages for internal threads and smooth gages for thread minor diameters

The GO thread plug gage and the NO-GO thread plug gage are used for the gaging of internal threads. GO and NO-GO plug gages are mounted on a common handle for thread diameters up to 40 mm and are designated as GO/NO-GO thread plug gages.

G-GUT-LD

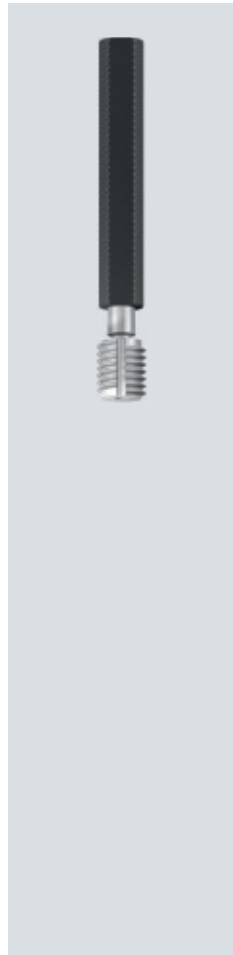

- The GO thread plug gage checks the so-called “mating size” of the internal thread and the screwing-in capability. In doing so, it checks the smallest size of the internal thread pitch diameter D_2 including certain form deviations in the thread, e.g. pitch and thread profile angle deviations. It also checks the smallest size of the major diameter. The minor diameter D_1 of the internal thread is not checked.
- The GO thread plug gage must be able to be screwed by hand into the full length of the workpiece thread without using particular force. The permissible wear of the GO thread plug gage is determined by measurement based on the three-wire-method. The GO thread plug gage is subject to heavy wear and should be checked at regular intervals. EMUGE therefore recommends using GO thread plug gages in the hard-chrome-plated or coated version.
- Dimensions of the GO thread plug gage acc. DIN 2281 and DIN 2282.
- The GO thread plug gage has a full thread profile along its thread length. It should be noted that the thread length is not less than 80% of the screw-in length of the workpiece thread. GO thread plug gages, starting from a thread diameter of 5.5 mm, are provided by EMUGE with a dirt flute.
- According to DIN ISO 1502, no so-called “acceptance” GO plug gages are standardized.
- It is advisable to always use the new plug gages for production and keep those that are close to the wear limit for acceptance.

G-AUS-LD



NO-GO thread plug gage

- The NO-GO thread plug gage checks whether the actual pitch diameter of the workpiece internal thread exceeds the prescribed largest size. The internal thread major diameter and internal thread minor diameter are not checked.
- It must not be possible to screw the NO-GO thread plug gage into the workpiece thread by hand for more than two revolutions (from both sides) without the use of particular force. The two revolutions are determined on screwing out the plug gage.
- The NO-GO thread plug gage has a thread length of at least three threads. The thread profile has a truncated crest.
- The gages are marked with a red coloured ring.
- Dimensions acc. DIN 2283 and DIN 2284.

For exceptional cases handles for GO/NO-GO thread plug gages up to a thread diameter of 62 mm are standardized in DIN 2240-2.

A (smooth) GO and NO-GO plug gage is recommended for gaging the internal thread minor diameter.

G-GR-LD



GO/NO-GO thread plug gage

- The GO/NO-GO thread plug gage is the combination of a GO thread plug gage and a NO-GO thread plug gage on one handle.
- The dimensions of the GO/NO-GO thread plug gages are specified up to a nominal dimension diameter of 40 mm in DIN 2280. The functionality corresponds to the GO and NO-GO thread plug gages previously described.

Glatt-GR-LD

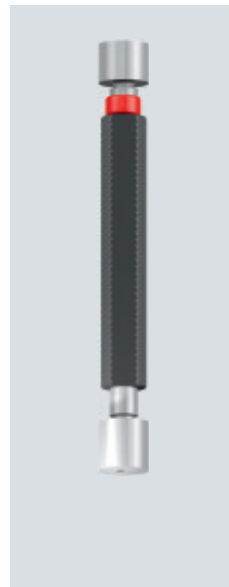

Gages for the internal thread minor diameter

- The internal thread minor diameter D_1 is checked with a smooth, cylindrical GO and NO-GO plug gage or a GO/NO-GO plug gage. As the minor diameter can change through thread tapping, an inspection is required after the thread has been completed. Specific gages are available to check the extended minor diameter tolerance of cold-formed Metric internal threads. Basically, the internal thread minor diameter should be checked before gaging the internal thread pitch diameter.
- It must be possible to guide the smooth GO plug gage by hand through the workpiece thread without the use of particular force.
- It must not be possible to insert the smooth NO-GO plug gage into the workpiece thread from both sides deeper than one pitch ($1 \times P$) from the start of the thread.

6.5 Smooth plug gages for drilled holes acc. DIN EN ISO 1938-1

The smooth GO plug gage and the smooth NO-GO plug gage are used for gaging fitting drilled holes. GO and NO-GO plug gages are mounted on one handle for drilled hole diameters up to 65 mm and are designated as smooth GO/NO-GO plug gages.

Glatt-GUT-LD



Smooth GO plug gage

- The smooth GO plug gage checks the minimum drilled hole dimension including certain form deviations, e.g. circularity and cylindricity.
- It must be possible to push the smooth GO plug gage by hand into the full length of the drilled hole without the use of particular force.
- To achieve higher wear resistance, EMUGE recommends using the smooth GO plug gage in the hard-chrome-plated or carbide version.
- Dimensions of the smooth GO plug gage acc. DIN 2246 and DIN 2248.

Glatt-AUS-LD



Smooth NO-GO plug gage

- The smooth NO-GO plug gage checks whether the drilled hole diameter has exceeded the prescribed maximum size.
- It must not be possible to insert the smooth NO-GO plug gage into the drilled hole without the use of particular force.
- The smooth NO-GO plug gage is marked with a red coloured ring.
- Dimensions of the smooth NO-GO plug gage acc. DIN 2247 and DIN 2249.

Product
Finder

UNC

UNF

UNS

M

MF

G (BSP)

Rp, R, Rc

NPT

NPTF

STI

SELF-LOCK

Smooth

GT, TD

Accessories

Calibration

Tech. Info



- Product Finder
- UNC
- UNF
- UNS
- M
- MF
- G (BSP)
- Rp, R, Rc
- NPT
- NPTF
- STI
- SELF-LOCK
- Smooth
- GT, TD
- Accessories
- Calibration
- Tech. Info

6.6 GT Thread depth plug gages

Introduction

The thread depth plug gages permit gaging and measuring of threads in one single step. These gages are used in components with identical thread dimensions but different thread depths as well as for setting up a thread depth for any kind of internal thread production.

The **GT-GR-LD** is a manually operated gage for gaging threads and their depths in one single step.

The **TD-Bit-GUT** is an automatically operated gage with bit holder (DIN ISO 1173) for use on cordless or pressurized air screwdrivers or drill machines in order to check any thread and its depth in one single step.

By pushing the spring-loaded scaled sleeve into the handle, the fully cut thread depth can be read off quickly and precisely from the display.

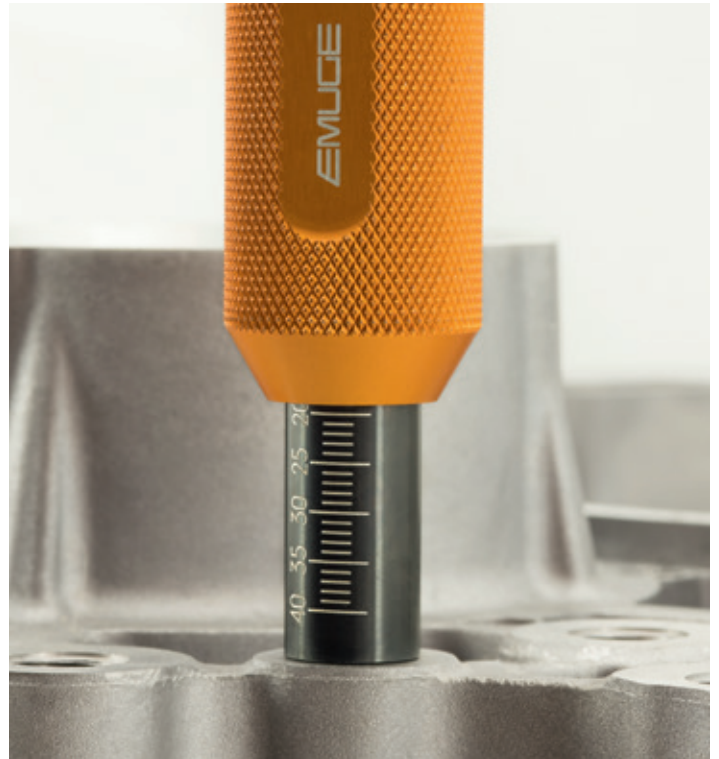

GT-GR-LD	TD-Bit-GUT
Manually operated gages	Automatically operated gages
 <p>4 x D</p>	 <p>2.5 x D</p>

Notable Features

- Reduction of the gaging time by approx. 50%
- Available in various sizes
- Easily adjustable
- Universally applicable
- Gages can be coated on demand
- Dimension accuracy 0.5 mm
- Set screw for fixing the scaled sleeve included on request
- Easy and safe performance
- Manually operated gages available on request with torque limiter

6.6 GT thread depth plug gages

The **thread depth plug gage “analog”** is plugged into the thread to be checked and then screwed down to the bottom. The total thread depth can be read off the scale from the point where the scaled sleeve disappears into the handle with a preciseness of 0.5 mm.

GT-GR-LD “analog” 4 x D



Manually operated gages

GT-GR-LD “analog” for manually gaging threads and their depths simultaneously. Manually operated gages can be fitted with a torque limiter on request for fine-adjustment of measuring depth of the thread. It allows to maintain a consistent screw-in torque but does not serve to transmit torque.

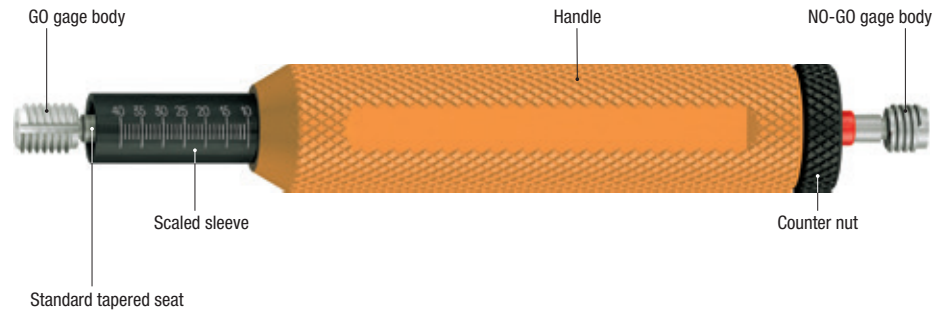

TD-Bit-GUT “analog” 2.5 x D



Automatically operated gages

The **TD-Bit-GUT “analog”** used together with a drive unit (e.g. a cordless or pressurized air screwdriver or drill machines) shortens gaging time and enables an effortless long-term working. Due to the DIN ISO 1173 hexagon 1/4" interface many **“TD-Bit-GUT”** might be driven with one single unit and can be exchanged rapidly. Independently of the user, automatic gaging with a constant torque improves the reproducibility of the results.

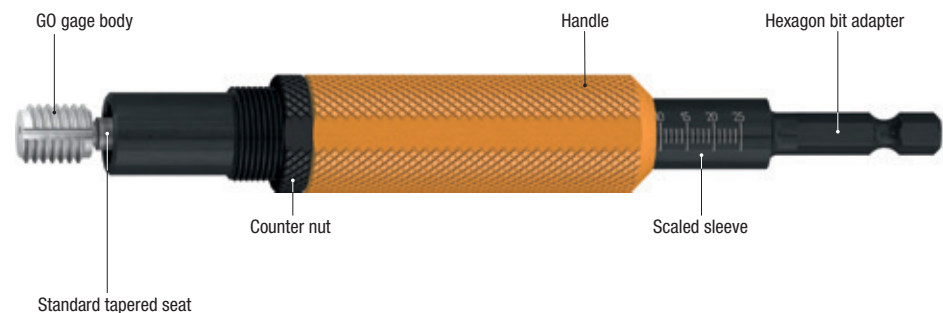

Product Finder

UNC

UNF

UNS

M

MF

G (BSP)

Rp, R, Rc

NPT

NPTF

STI

SELF-LOCK

Smooth

GT, TD

Accessories

Calibration

Tech. Info



- Product Finder
- UNC
- UNF
- UNS
- M
- MF
- G (BSP)
- Rp, R, Rc
- NPT
- NPTF
- STI
- SELF-LOCK
- Smooth
- GT, TD
- Accessories
- Calibration
- Tech. Info**

6.7 Gaging of other threads

Thread gages for other threads (sealing threads, tapered threads, threads for tight fit, SELF-LOCK threads etc.) often deviate considerably from the normal gage design. They are usually adjusted to the special design and function of these threads.

One good example are the thread gages for sealing threads, e.g. NPT and NPTF threads acc. US standards, or pipe sealing threads acc. DIN EN 10226 / ISO 7. In such cases, the instructions for the gaging of these threads must be observed in every detail.

6.7.1 The gaging of the EMUGE SELF-LOCK thread

We recommend using our two-piece gage system which corresponds to the usual combination of GO and NO-GO gage and is perfectly sufficient for the gaging of the thread, provided that the SELF-LOCK threads were produced with our true-to-profile EMUGE taps.

There is no generally applicable standard (e.g. DIN standard) for the EMUGE SELF-LOCK thread, so other manufacturers may use different limit sizes for their threads. For this reason, we recommend gaging EMUGE SELF-LOCK threads exclusively with EMUGE SELF-LOCK gages. With the GO plug gage, it is important to observe the correct screw-in direction. The NO-GO side can be used in either screw-in direction.

GO/NO-GO plug gage for the EMUGE SELF-LOCK thread

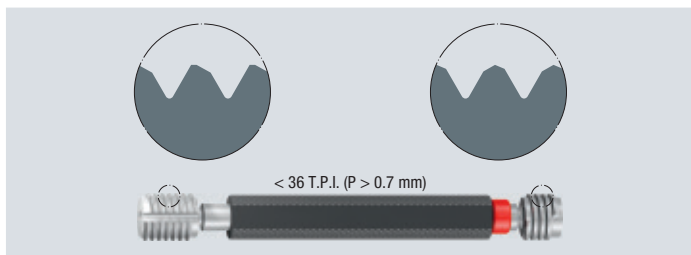

Whenever threads are produced by chasing or thread milling, we recommend the additional use of our EMUGE HRPG gage which checks the lower end of the ramp, and helps to identify any deviations in the angle of the ramp.

HRPG NO-GO plug gage for the EMUGE SELF-LOCK thread

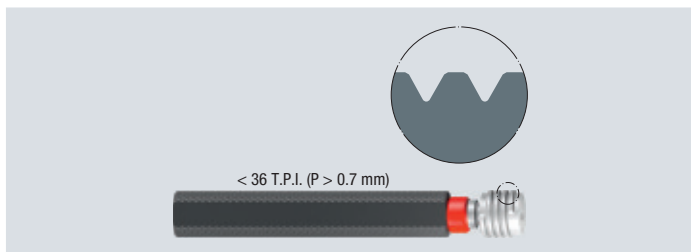

The gaging of the buttress profile works on the same principle, with the only difference that both the GO and the NO-GO plug gage have to be used in the correct direction.

GO/NO-GO plug gage for the EMUGE SELF-LOCK buttress thread

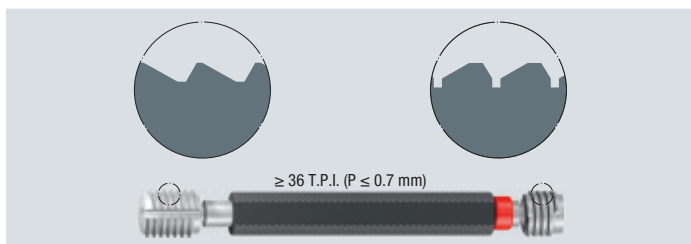

6.7.2 American Pipe Thread, thread angle 60°

6.7.2.1 Pipe thread for general applications (with sealant) according to ANSI/ASME B1.20.1

- Overview:
- NPT**
 - NPSC**
 - NPTR**
 - NPSM**
 - NPSL**
 - NPSH**

Each letter in the designation has the following meaning:

N	National (American) Standard
P	Pipe
T	Taper
C	Coupling
S	Straight
M	Mechanical
L	Locknut
H	Hose coupling
R	Railing fittings

The thread profile is **symmetrical** and **perpendicular** to the thread axle!

NPT thread

- Tapered internal thread and external thread
- Tapered plug gages L₁ with 3 measuring steps (Min., Basis, Max.)
- Tapered ring gages L₁ with 3 measuring steps (Min., Basis, Max.)

NPSC thread

- Cylindrical internal thread for pressure-tight connections, is screwed with a tapered external thread NPT and an additional sealing
- Tapered plug gages L₁ mit 3 measuring steps (Min., Basis, Max.)

NPTR threads

- Tapered internal thread and external thread for the rigid mechanical screwing of railing fittings (similar to NPT).

NPSM thread

- Cylindrical internal and external thread for mechanical "Free-Fitting" connections and fastening primarily of pipes without internal pressure
- Ring gages and plug gages GO and NO-GO are cylindrical!

NPSL thread

- Cylindrical internal and external thread for mechanical "Loose-Fitting" connections with locknut, e.g. through container walls and tightened with locknuts on both sides
- Ring gages and plug gages GO and NO-GO are cylindrical!

NPSH thread

- Cylindrical internal and external thread for mechanical "Loose-Fitting" connections of hose couplings
- Ring gages and plug gages GO and NO-GO are cylindrical!

6.7 Gaging of other threads

6.7.2.2 Pipe thread for dryseal connections (without sealant) according ANSI B1.20.3

Overview: **NPTF**
PTF-SAE-SHORT
NPSF
NPSI

Each letter in the designation has the following meaning:

N	National (American) Standard
P	Pipe
T	Taper
S	Straight
F	Fuel and oil
I	Intermediate

The thread profile is **asymmetrical** and **perpendicular** to the thread axle!

NPTF thread

- Tapered internal thread and external thread

Gage system NPTF-1

- Tapered plug gages L_1 with 3 measuring steps (Min., Basis, Max.)
- Tapered plug gages L_3 with 3 measuring steps (Min., Basis, Max.)
- Tapered ring gages L_1 with 3 measuring steps (Min., Basis, Max.)
- Tapered ring gages L_2 with 3 measuring steps (Min., Basis, Max.)

Gage system NPTF-2 according to ASME B1.20.5

- Tapered plug gage L_1 with 4 measuring steps
- Tapered plug gage L_3 with 4 measuring steps
- Tapered smooth plug gage "Crest Check" with 6 measuring steps for minor diameter of nut
- Tapered plug gage "Root Check", thread angle 50° , with 6 measuring steps for major diameter of nut
- Tapered ring gage L_1 with 4 measuring steps
- Tapered ring gage L_2 with 4 measuring steps
- Tapered smooth ring gage "Crest Check" with 6 measuring steps for major diameter of bolt
- Tapered ring gage "Root Check", thread angle 50° , with 6 measuring steps for minor diameter of bolt

PTF-SAE-SHORT thread

- Tapered internal thread PTF-SAE-SHORT, is coupled with a tapered NPTF external thread
- Tapered plug gages L_1 with 3 measuring steps (Min., Basis, Max.)
- Tapered plug gages L_3 with 3 measuring steps (Min., Basis, Max.)

NPSF thread

- Cylindrical internal thread, is screwed with a tapered external thread NPTF
- Tapered plug gages L_1 with 3 measuring steps (Min., Basis, Max.)

NPSI thread

- Cylindrical internal thread, is screwed with a tapered external thread NPTF
- Tapered plug gages L_1 with 3 measuring steps (Min., Basis, Max.)

6.7.3 Whitworth Pipe Thread, thread angle 55°

6.7.3.1 Pipe thread for general applications

Rp	= Cylindrical internal pipe thread (parallel)
Rc	= Tapered internal pipe thread
R	= Tapered external pipe thread

The thread profile is **symmetrical** with top and bottom triangles rounded to a circular peak!

The thread dimensions of bolt and nut are specified in several national and international standards,

e.g.: **ISO 7/1**

DIN EN ISO 10226-1

DIN EN ISO 10226-2

etc.

Internal threads Rp and Rc

Gaging is done according to ISO 7/2 resp. DIN EN 10226-3

- Tapered plug gages no. 1 with 1 measuring step ("+", "-") for standard screw connections
- Tapered plug gages no. 2 with 1 measuring step ("+", "-") for checking screw-in depth
- Cylindrical check ring gage no. 6 without measuring step for checking gages no. 1 and no. 2

Tapered external thread R

Gaging is done according to ISO 7/2 resp. DIN EN 10226-3

- Cylindrical ring gage no. 3 with 1 measuring step ("+", "-")
- Tapered smooth ring gage no. 4 with measuring step ("+", "-") for checking the major diameter of the bolt
- Tapered plug gage no. 5 with 1 measuring step for checking gage no. 3

6.7.3.2 Whitworth pipe thread for special screw connections

- **DIN 3858** = shorter thread lengths
- **DIN 477, DIN EN 144-1, DIN EN ISO 11363** = gas cylinder valves

DIN 3858

Cylindrical internal thread for pipe screw connections with short thread length, is screwed with tapered external thread!

- Cylindrical ring gage with 1 measuring step for **standard version (tolerance zone position 1)**
- Cylindrical ring gage with 1 measuring step for **short version (tolerance zone position 2)**
- Cylindrical plug gage GO/NO-GO for checking the Rp internal thread



- Product Finder
- UNC
- UNF
- UNS
- M
- MF
- G (BSP)
- Rp, R, Rc
- NPT
- NPTF
- STI
- SELF-LOCK
- Smooth
- GT, TD
- Accessories
- Calibration
- Tech. Info

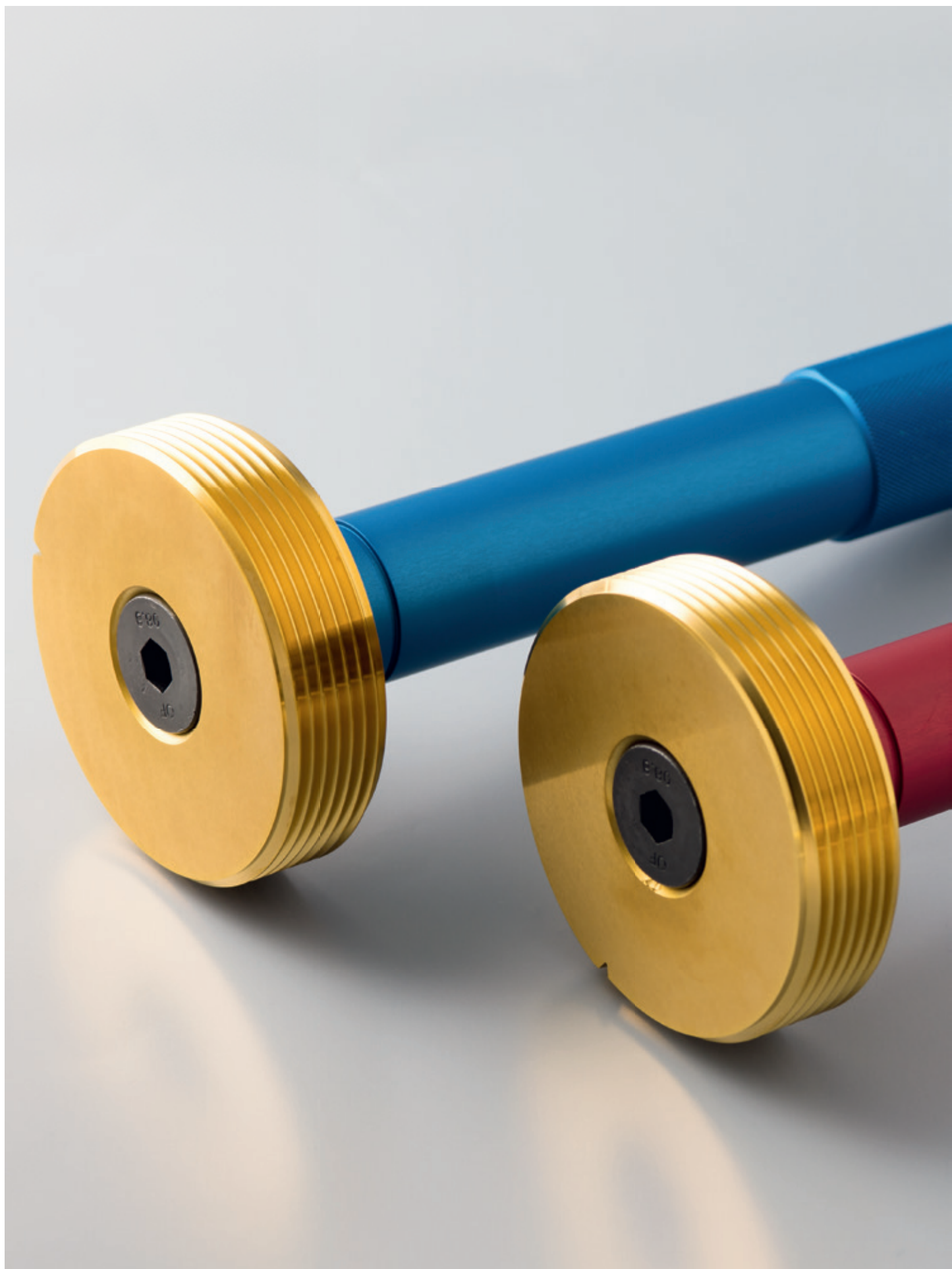











Tap Holders

	Page
Contents	478 - 481
Product Pages	483 - 630
Technical Information	631 - 650



- Product Finder
- Softsynchro
- Speedsynchro
- KSN
- MQL
- SFM
- HF
- EM
- Accessories
- Tech. Info

	Cooling and lubrication				Functions							
	Internal coolant supply (IKZ)	Minimum-quantity lubrication (MQL)	Coolant pressure at the entry to the holder		Air pressure at the entry to the holder	Length compensation on compression and tension	Minimal length compensation	Length compensation on tension	Length readjustment	Pressure-point mechanism	Front release	Axial-parallel floating
			p_{max} 100bar (1400psi)	p_{max} 50bar (700psi)	p_{max} 6bar (85psi)							
Softsynchro® Micro							■					
Softsynchro® 0-5	■			■			■					
Softsynchro® 6	■			■			■					
Softsynchro®/PGR	■			■			■					
Softsynchro®/Modular/IKZ	■			■			■		■			
Softsynchro®/MMS		■			■		■					
Softsynchro®/Modular/MQL		■			■		■		■			
Speedsynchro®/Modular/IKZ	■			■			■		■			
Speedsynchro®/Modular/MQL		■			■		■		■			
KSN						■				■	■	
KSN/HD	■			■		■				■	■	
KSN/HD/ER	■			■		■				■		
KSN/HD/PGR	■			■		■				■		
KSN/Synchro	■		■									
KSN/MQL		■			■	■				■	■	
SFM												
SFM-NP												■
SFM-L-DZ						■				■		
HF						■						

Description of the symbols of performance characteristics ►► 632 - 635

New EC Machinery Directive 2006/42/EC

The new version of the EC Machinery Directive 2006/42/EC which became effective on 31 December 2009 now also contains requirements for so-called incomplete machines. This includes also tool and workpiece clamping devices which are installed into other machines as machine components, or assembled into a unit with them.

On manuals.emugedownloads.com we have compiled for you all the information from the EC Machinery Directive 2006/42/EC which may be necessary for the use of our products.

Functions			Tool adaptation				Recommended range of application				
Transmission gearing rapid traverse	Overload clutch	Drilling and countersinking	Tool adaptation by means of quick-change adapters, EM series	Tool adaptation by means of quick-change adapters, HE series	Tool adaptation by means of collets, type ER (GB)	Tool adaptation by means of collets, type PGR-GB	For use on machines with synchronous spindle	For use on CNC machining centres and other machine tools	For use on multi-spindle machines and transfer lines	For use on pillar drilling machines	
											Softsynchro® Micro
					■		■				Softsynchro® 0-5
				■			■				Softsynchro® 6
						■	■				Softsynchro®/PGR
					■		■				Softsynchro®/Modular/IKZ
					■		■				Softsynchro®/MMS
					■		■				Softsynchro®/Modular/MQL
■					■		■				Speedsynchro®/Modular/IKZ
■					■		■				Speedsynchro®/Modular/MQL
			■					■		■	KSN
			■					■			KSN/HD
					■			■			KSN/HD/ER
						■		■			KSN/HD/PGR
					■						KSN/Synchro
			■					■			KSN/MQL
			■						■		SFM
			■						■		SFM-NP
			■						■		SFM-L-DZ
	■	■		■			■			■	HF

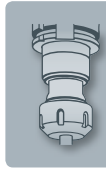

- Product Finder
- Softsynchro
- Speedsynchro
- KSN
- MQL
- SFM
- HF
- EM
- Accessories
- Tech. Info

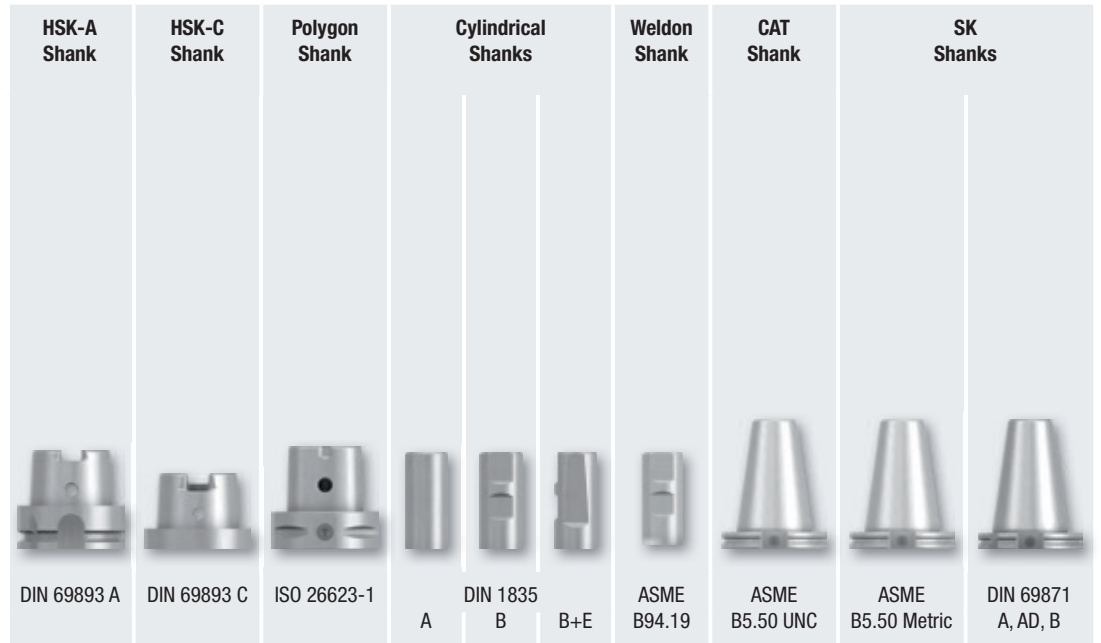

Page

Softsynchro® Micro	484			495, 496	492				
Softsynchro® 0-5	485 - 486, 488	490	491		493	494	497		498 - 499
Softsynchro® 6	487								500
Softsynchro®/Modular/IKZ	489								
Softsynchro®/PGR	505				506				
Softsynchro®/MMS	548 - 549	550							
Softsynchro®/Modular/MQL	552 - 555	556 - 557							
Speedsynchro®/Modular/IKZ				508					
Speedsynchro®/Modular/MQL									
KSN	512	513			514	515	516	517	518
KSN/HD	527	528	529		530	531			532
KSN/HD/ER	537	538			539				
KSN/HD/PGR	540				541				
KSN/Synchro	542				543	544			545
KSN/MQL	559 - 560	561							
SFM									
SFM-NP									
SFM-L-DZ									
HF							576 - 577		576 - 577

Further shank types upon request

Shanks for Driven Tools

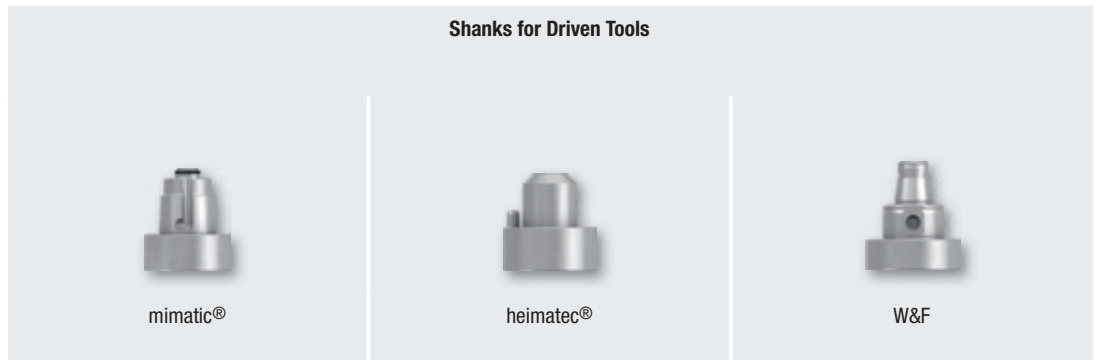

Softsynchro® 1	502	503	504
-----------------------	-----	-----	-----

SK Shanks		BT Shank	Morse Taper Shank	Trapezoidal Shank	ACME Shank	VDI Shank	ABS® Shank
DIN 2080	ANSI B5.18 NMPT	JIS B 6339 (MAS 403 BT)	DIN 228 B (ASME B5.10)	DIN 6327	ASME B5.11	DIN ISO 10889 (VDI 3425)	ABS® (System KOMET)

- Product Finder
- Softsynchro
- Speedsynchro
- KSN
- MLQ
- SFM
- HF
- EM
- Accessories
- Tech. Info

Page

								Softsynchro® Micro
		501						Softsynchro® 0-5
								Softsynchro® 6
								Softsynchro®/Modular/IKZ
								Softsynchro®/PGR
								Softsynchro®/MMS
								Softsynchro®/Modular/MQL
							509	Speedsynchro®/Modular/IKZ
							510, 558	Speedsynchro®/Modular/MQL
519	520	521	522	523	524	525	526	KSN
				533	534	535	536	KSN/HD
								KSN/HD/ER
								KSN/HD/PGR
								KSN/Synchro
								KSN/MQL
			566	567	568			SFM
				569	570			SFM-NP
			571	572	573			SFM-L-DZ
	576 - 577		576 - 577					HF

Page

	Quick-change adapters type EM	583 - 601
	Accessories for tap holders	603 - 630

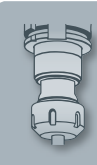

- Product Finder
- Soft-synchro
- Speed-synchro
- KSN
- MQL
- SFM
- HF
- EM
- Accessories
- Tech. Info

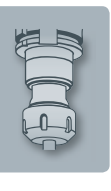

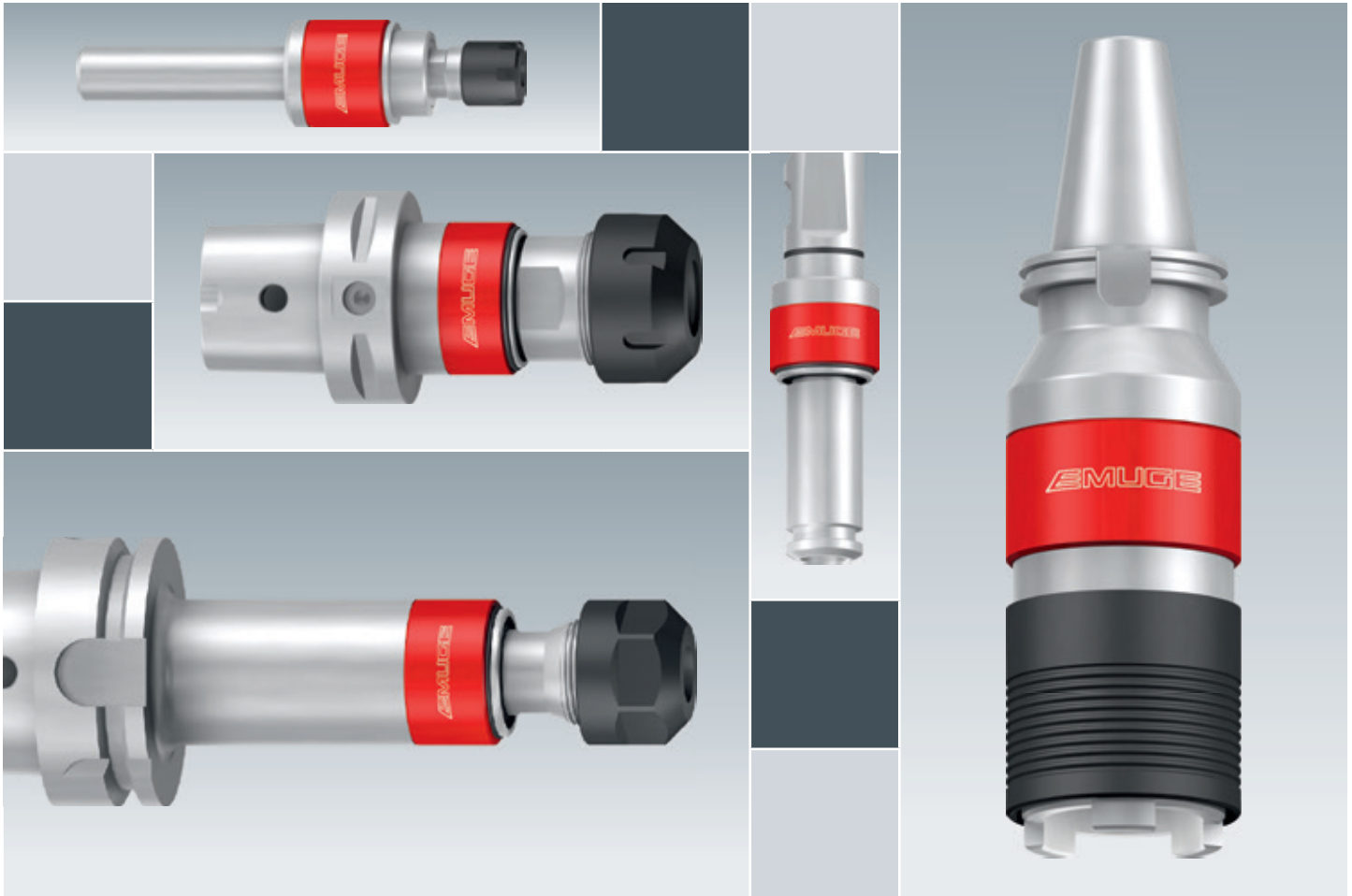

Softsynchro® Series

Application on machines with synchronous spindle

The threading tool is pitch-controlled by the synchronous spindle; eventually arising axial forces caused by synchronisation faults are minimized by a patent-protected minimum length compensation on tension and on compression.



- Product Finder
- Softsynchro
- Speedsynchro
- KSN
- MQL
- SFM
- HF
- EM
- Accessories
- Tech. Info

Softsynchro®

HSK-A Shank

DIN 69893 A

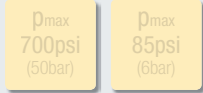
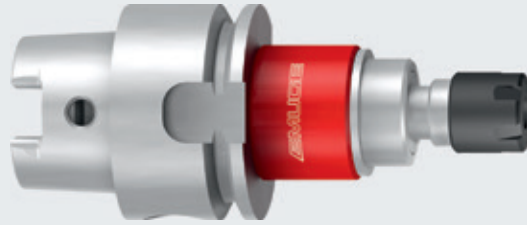

For use on machines with synchronous spindle

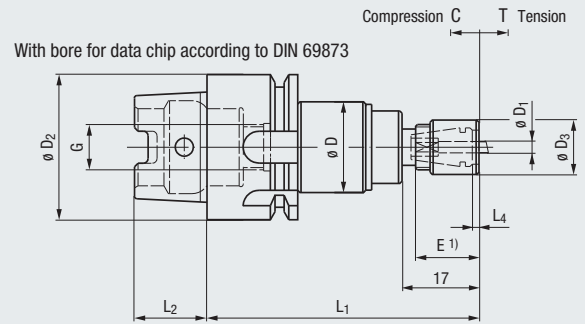

Type		$\varnothing D_1$			Shank Size $\varnothing D_2$	mm								EDP Number	★
						$\varnothing D$	$\varnothing D_3$	L_1	L_2	L_4	G	C	T		
Softsynchro® Micro	M0.5 - M4 (No.0 - No.8)	2 - 4.5 mm 0.141 - 0.168	ER 8	Hi-Q/ERM 8	HSK-A32	20	12	60	16	1.5	M10 x 1	0.2	0.2	F3150C01	★

1) Clamping depths E, see page 624 - 625

Further designs upon request

Clamping nut without integrated seal is included in the delivery

Accessories

- Collets type ER (GB) ▶▶ 610 - 613
- Set of clamping wrenches ▶▶ 621
- Coolant tubes and wrenches ▶▶ 606 - 607
- Torque wrenches TORCO-FIX ▶▶ 623

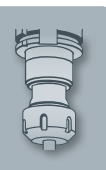

Softsynchro®

HSK-A Shank

DIN 69893 A

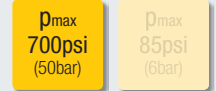
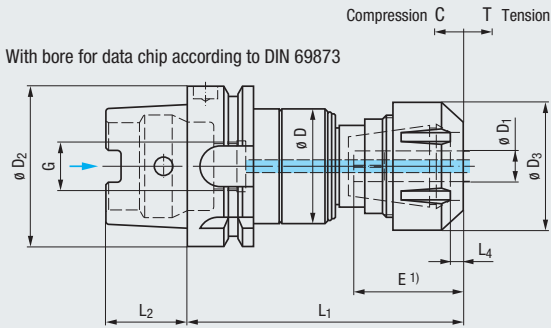
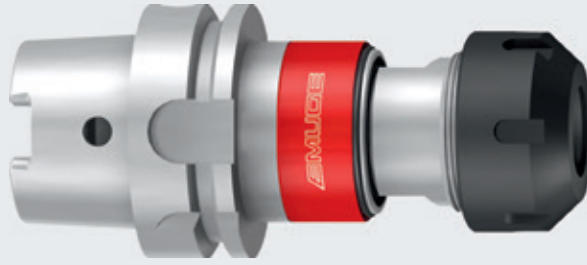

For use on machines with synchronous spindle

Type	Image	ø D ₁	Image	Image	Shank Size ø D ₂	mm										EDP Number	★
						ø D	ø D ₃	L ₁ ER	L ₁ ER-GB	L ₂	L ₄	G	C	T			
Softsynchro® 0	M2 - M8 (No.2 - 5/16)	2.5 - 7 mm 0.141 - 0.194	ER 11 (GB)	Hi-Q/ERM 11	HSK-A40	34	16	89.2	87.5	20	0.9	M12 x 1	0.5	0.5	F3150C02.1	★	
					HSK-A50	34	16	93.2	91.5	25	0.9	M16 x 1	0.5	0.5	F3150C03.1	★	
					HSK-A63	34	16	95.2	93.5	32	0.9	M18 x 1	0.5	0.5	F3150C04.1	★	
					HSK-A80	34	16	99.7	98	40	0.9	M20 x 1.5	0.5	0.5	F3150C05.1	★	
					HSK-A100	34	16	101.7	100	50	0.9	M24 x 1.5	0.5	0.5	F3150C06.1	★	
Softsynchro® 1	M4 - M12 (No.8 - 7/16)	4.5 - 10 mm 0.168 - 0.381	ER 20 (GB)	Hi-Q/ERC 20	HSK-A40	34	34	-	89.5	20	5	M12 x 1	0.5	0.5	F3151C02.1	★	
					HSK-A50	34	34	-	93.5	25	5	M16 x 1	0.5	0.5	F3151C03.1	★	
					HSK-A63	34	34	-	95.5	32	5	M18 x 1	0.5	0.5	F3151C04.1	★	
					HSK-A80	34	34	-	100	40	5	M20 x 1.5	0.5	0.5	F3151C05.1	★	
					HSK-A100	34	34	-	102	50	5	M24 x 1.5	0.5	0.5	F3151C06.1	★	
Softsynchro® 3	M4 - M20 (1/4 - 3/4)	4.5 - 16 mm 0.255 - 0.590	ER 32 (GB)	Hi-Q/ERC 32	HSK-A50	45	50	-	116.3	25	5	M16 x 1	0.5	0.5	F3153C03.1	★	
					HSK-A63	45	50	-	108.8	32	5	M18 x 1	0.5	0.5	F3153C04.1	★	
					HSK-A80	45	50	-	113.3	40	5	M20 x 1.5	0.5	0.5	F3153C05.1	★	
					HSK-A100	45	50	-	115.3	50	5	M24 x 1.5	0.5	0.5	F3153C06.1	★	
Softsynchro® 4	M12 - M30 (7/16 - 1 1/8)	9 - 22 mm 0.255 - 0.800	ER 40 (GB)	Hi-Q/ERC 40	HSK-A63	63	63	-	146.5	32	5	M18 x 1	0.7	0.7	F3154C04.1	★	
					HSK-A80	63	63	-	136	40	5	M20 x 1.5	0.7	0.7	F3154C05.1	★	
					HSK-A100	63	63	-	138	50	5	M24 x 1.5	0.7	0.7	F3154C06.1	★	

1) Clamping depths E, see page 624 - 625

Further designs upon request

Softsynchro® 0

Clamping nut without integrated seal is included in the delivery

Softsynchro® 1-4

Clamping nut for sealing disks is included in the delivery

Accessories

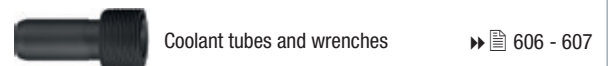
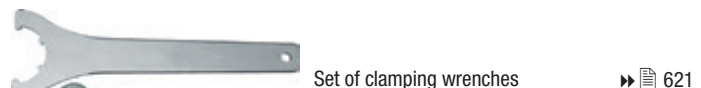
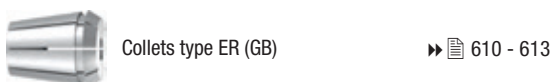

● = In stock
★ = Allow 7 days for delivery

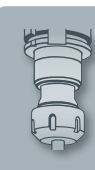

Softsynchro®

HSK-A Shank

DIN 69893 A

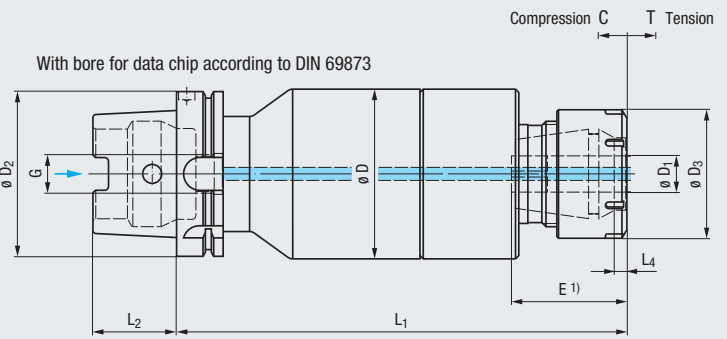
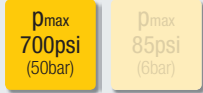

For use on machines with synchronous spindle

Type		$\varnothing D_1$			Shank Size $\varnothing D_2$	mm										EDP Number	★
						$\varnothing D$	$\varnothing D_3$	L_1 ER	L_1 ER-GB	L_2	L_4	G	C	T			
Softsynchro® 5	M30 - M48 (1 - 1 1/2)	22 - 36 mm 0.800 - 1.233	ER 50 (GB)	Hi-Q/ERBC 50	HSK-A100	103	78	269	265.6	50	8	M24 x 1.5	2	2	F3155C06.1		

1) Clamping depths E, see page 624 - 625

Further designs upon request

Clamping nut for sealing disks is included in the delivery

Square seat for tools with shank diameter 36 mm is integrated in the tap holder body

Accessories

- Collets type ER (GB) ▶▶ 610 - 613
- Sealing disks type DS/ER ▶▶ 616
- Clamping wrenches ▶▶ 621
- Coolant tubes and wrenches ▶▶ 606 - 607
- Torque wrenches TORCO-FIX ▶▶ 623

Softsynchro®

HSK-A Shank

DIN 69893 A

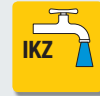

p_{max}
700psi
(50bar)

p_{max}
85psi
(6bar)



For use on machines
with synchronous spindle

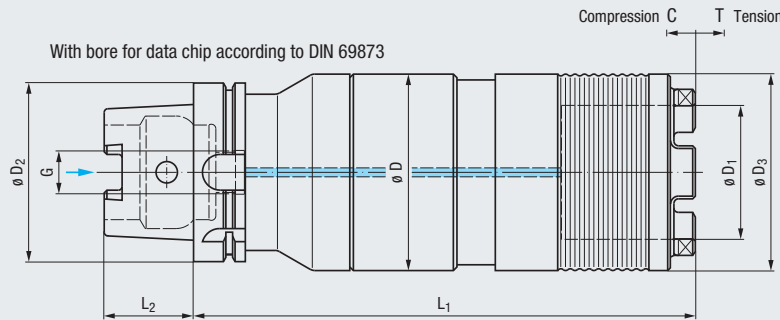

Type			Shank Size $\varnothing D_2$	mm								EDP Number	★
				$\varnothing D$	$\varnothing D_1$	$\varnothing D_3$	L_1	L_2	G	C	T		
Softsynchro® 6	M45 - M76 (1 3/8 - 2 3/8)	HE2/IKZZ	HSK-A100	110	75	110	281	50	M24 x 1.5	2	2	F3156C06.1	★

Further designs upon request

Accessories



Quick-change adapters type HE2/IKZZ ▶▶ 578 - 579



Coolant tubes and wrenches ▶▶ 606 - 607

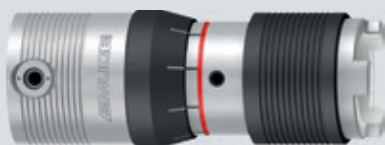

Further quick-change tap holders (HF series)
for the production of large threads, see pages 576



Softsynchro®

HSK-A Shank

DIN 69893 A

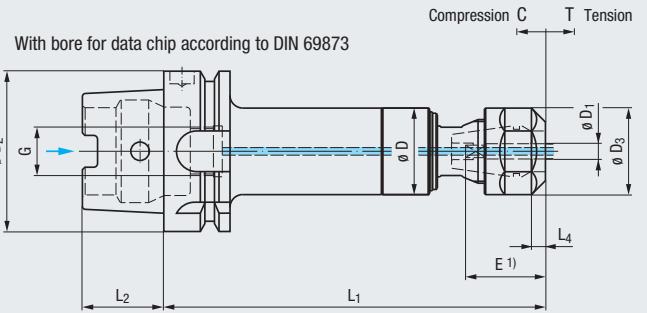
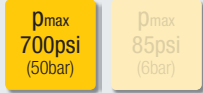
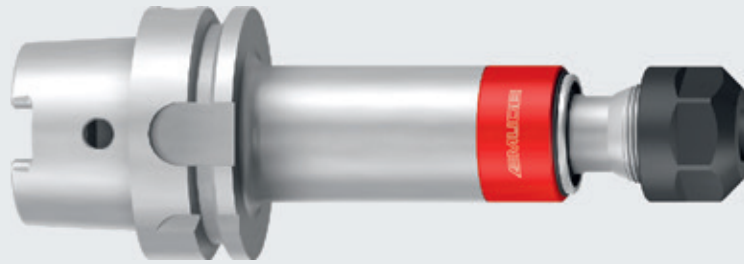

For use on machines with synchronous spindle

Type	Image	$\varnothing D_1$	Image	Image	Shank Size $\varnothing D_2$	mm							EDP Number	★	
						$\varnothing D$	$\varnothing D_3$	L_1	L_2	L_4	G	C			T
Softsynchro® 1	M4 - M12 (No.8 - 7/16)	4.5 - 10 mm 0.168 - 0.381	ER 20 (GB)	Hi-Q/ERC 20	HSK-A63	34	34	125	32	5	M18 x 1	0.5	0.5	F3151037.1	★
					HSK-A63	34	34	150	32	5	M18 x 1	0.5	0.5	F3151918.1	★
					HSK-A63	34	34	175	32	5	M18 x 1	0.5	0.5	F3151038.1	★

1) Clamping depths E, see page 624 - 625

Further designs upon request

Clamping nut for sealing disks is included in the delivery

Accessories

- 
Collets type ER (GB) ▶▶ 610 - 613
- 
Sealing disks type DS/ER ▶▶ 616
- 
Set of clamping wrenches ▶▶ 621
- 
Assembly device ▶▶ 621
- 
Coolant tubes and wrenches ▶▶ 606 - 607
- 
Torque wrenches TORCO-FIX ▶▶ 623

Softsynchro® Modular/IKZ

HSK-A Shank

DIN 69893 A

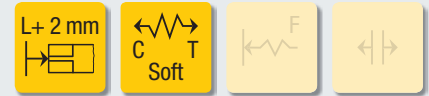
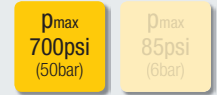
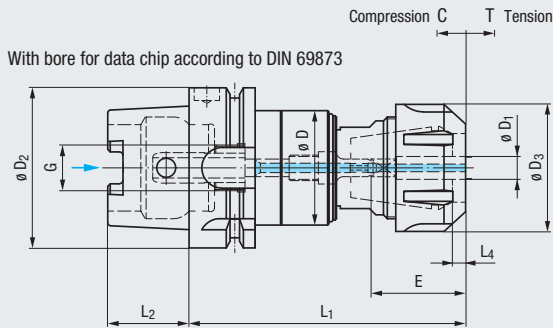
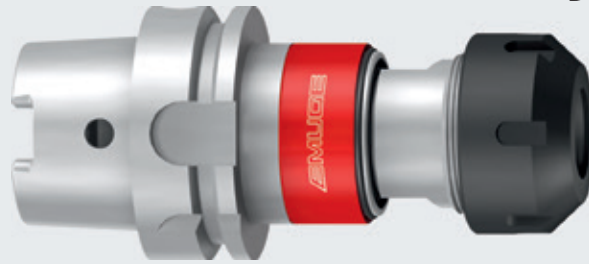

For use on machines with synchronous spindle

new	Type	Collet	$\varnothing D_1$	Clamping Nut	Shank Size $\varnothing D_2$	mm							EDP Number		
						$\varnothing D$	$\varnothing D_3$	L_1	L_2	L_4	G	C			T
Softsynchro® 1/Modular/IKZ	M4.5 - M10	6 / 7 mm	ER 20 (GB)	Hi-Q/ERC 20	HSK-A40	34	34	89.5	20	5	M12 x 1	0.5	0.5	F3541C02.1.01	★
					HSK-A63	34	34	95.5	32	5	M18 x 1	0.5	0.5	F3541C04.1.01	★
					HSK-A100	34	34	102	50	5	M24 x 1.5	0.5	0.5	F3541C06.1.01	★
	M8, M9, M11, M12	8 / 9 mm	ER 20 (GB)	Hi-Q/ERC 20	HSK-A40	34	34	89.5	20	5	M12 x 1	0.5	0.5	F3541C02.1.02	★
					HSK-A63	34	34	95.5	32	5	M18 x 1	0.5	0.5	F3541C04.1.02	★
					HSK-A100	34	34	102	50	5	M24 x 1.5	0.5	0.5	F3541C06.1.02	★
	M10	10 mm	ER 20 (GB)	Hi-Q/ERC 20	HSK-A40	34	34	89.5	20	5	M12 x 1	0.5	0.5	F3541C02.1.03	★
					HSK-A63	34	34	95.5	32	5	M18 x 1	0.5	0.5	F3541C04.1.03	★
					HSK-A100	34	34	102	50	5	M24 x 1.5	0.5	0.5	F3541C06.1.03	★
Softsynchro® 3/Modular/IKZ	M12	9 mm	ER 32 (GB)	Hi-Q/ERC 32	HSK-A63	45	50	108.8	32	5	M18 x 1	0.5	0.5	F3543C04.1.01	★
					HSK-A100	50	50	115.3	50	5	M24 x 1.5	0.5	0.5	F3543C06.1.01	★
	M10 - M16	10 - 12 mm	ER 32 (GB)	Hi-Q/ERC 32	HSK-A63	45	50	108.8	32	5	M18 x 1	0.5	0.5	F3543C04.1.02	★
					HSK-A100	50	50	115.3	50	5	M24 x 1.5	0.5	0.5	F3543C06.1.02	★
	M18 - M20	14 - 16 mm	ER 32 (GB)	Hi-Q/ERC 32	HSK-A63	45	50	108.8	32	5	M18 x 1	0.5	0.5	F3543C04.1.03	★
					HSK-A100	50	50	115.3	50	5	M24 x 1.5	0.5	0.5	F3543C06.1.03	★

Clamping nut for sealing disks, coolant tube and length adjustment screw are included in the delivery

Further designs upon request

Clamping depths

$\varnothing D_1$ mm	E mm	
	min.	max.
6	29	31
7	29	31
8	34	36
9	35	37
10	39	41
11	40	42
12	40	42
14	42	44
16	43	45

Accessories



● = In stock
★ = Allow 7 days for delivery

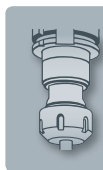

Softsynchro®

HSK-C Shank

DIN 69893 C

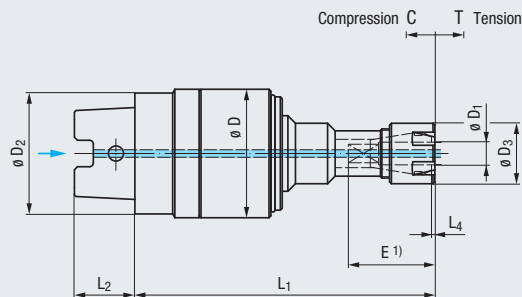

For use on machines with synchronous spindle

Type	Shank Size ø D ₂	ø D ₁	ER	Hi-Q/ERM	Shank Size ø D ₂	mm								EDP Number	
						ø D	ø D ₃	L ₁ ER	L ₁ ER-GB	L ₂	L ₄	C	T		
Softsynchro® 0	M2 - M8 (No.2 - 5/16)	2.5 - 7 mm 0.141 - 0.194	ER 11 (GB)	Hi-Q/ERM 11	HSK-C32	34	16	81.2	79.5	16	0.9	0.5	0.5	F3150K01.1	★
					HSK-C40	34	16	81.2	79.5	20	0.9	0.5	0.5	F3150K02.1	★
Softsynchro® 1	M4 - M12 (No.8 - 7/16)	4.5 - 10 mm 0.168 - 0.381	ER 20 (GB)	Hi-Q/ERC 20	HSK-C32	34	34	—	81.5	16	5	0.5	0.5	F3151K01.1	★
					HSK-C40	34	34	—	81.5	20	5	0.5	0.5	F3151K02.1	★

1) Clamping depths E, see page 624 - 625

Further designs upon request

Softsynchro® 0

Clamping nut without integrated seal is included in the delivery

Softsynchro® 1

Clamping nut for sealing disks is included in the delivery

Accessories



Collets type ER (GB)

▶▶ 610 - 613



Sealing disks type DS/ER

▶▶ 616



Clamping nut with integrated seal, type Hi-Q/ERMC 11

▶▶ 618



Set of clamping wrenches

▶▶ 621



Assembly device

▶▶ 621



Torque wrenches TORCO-FIX

▶▶ 623

Softsynchro®

PSC Shank

ISO 26623-1

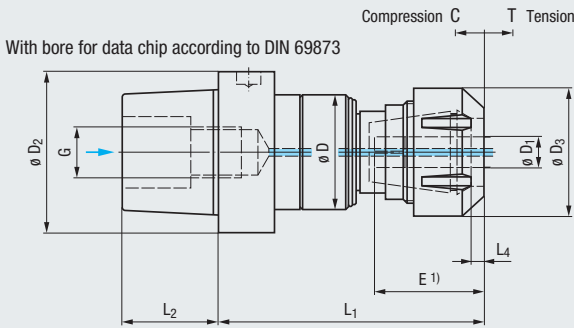

IKZ

MQL

p_{max}
700psi
(50bar)

p_{max}
85psi
(6bar)

C T

F

For use on machines with synchronous spindle

Type	Shank Size ø D ₂	ø D ₁	ER (GB)	Hi-Q/ERM/ERC	mm										EDP Number	★		
					ø D	ø D ₃	L ₁ ER	L ₁ ER-GB	L ₂	L ₄	G	C	T					
Softsynchro® 0	M2 - M8 (No.2 - 5/16)	2.5 - 7 mm 0.141 - 0.194	ER 11 (GB)	Hi-Q/ERM 11	PSC 63	34	16	95	93.2	38	0.9	M20 x 2	0.5	0.5	F3150T06.1	★		
Softsynchro® 1	M4 - M12 (No.8 - 7/16)	4.5 - 10 mm 0.168 - 0.381	ER 20 (GB)	Hi-Q/ERC 20	PSC 40	34	34	-	89.5	24	5	M14 x 1.5	0.5	0.5	F3151T04.1	★		
					PSC 50	34	34	-	89.5	30	5	M16 x 1.5	0.5	0.5			F3151T05.1	★
					PSC 63	34	34	-	93.5	38	5	M20 x 2	0.5	0.5				
Softsynchro® 3	M4 - M20 (1/4 - 3/4)	4.5 - 16 mm 0.255 - 0.590	ER 32 (GB)	Hi-Q/ERC 32	PSC 40	45	50	-	104	24	5	M14 x 1.5	0.5	0.5	F3153T04.1	★		
					PSC 50	45	50	-	103	30	5	M16 x 1.5	0.5	0.5			F3153T05.1	★
					PSC 63	45	50	-	107	38	5	M20 x 2	0.5	0.5				
Softsynchro® 4	M12 - M30 (7/16 - 1 1/8)	9 - 22 mm 0.255 - 0.800	ER 40 (GB)	Hi-Q/ERC 40	PSC 63	63	63	-	129.5	38	5	M20 x 2	0.7	0.7	F3154T06.1	★		
					PSC 80	63	63	-	134	48	5	M20 x 2	0.7	0.7			F3154T08.1	★

1) Clamping depths E, see page 624 - 625

Further designs upon request

Softsynchro® 0

Clamping nut without integrated seal is included in the delivery

Softsynchro® 1-4

Clamping nut for sealing disks is included in the delivery

Accessories



Collets type ER (GB)

» 610 - 613



Sealing disks type DS/ER

» 616



Clamping nut with integrated seal, type Hi-Q/ERM 11

» 618



Set of clamping wrenches

» 621



Assembly device

» 621



Torque wrenches TORCO-FIX

» 623



- Product Finder
- Soft-synchro
- Speed-synchro
- KSN
- MQL
- SFM
- HF
- EM
- Accessories
- Tech. Info

Softsynchro® Cylindrical Shank DIN 1835 B+E

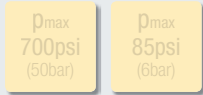

For use on machines with synchronous spindle

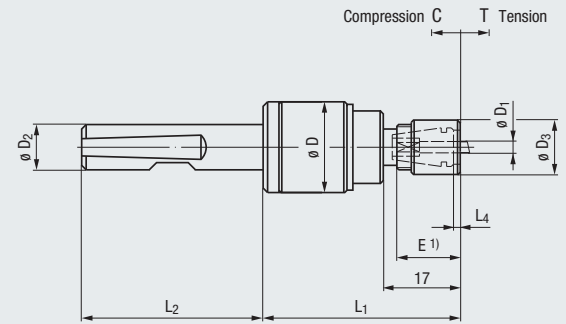

Type		ϕD_1			Shank Size ϕD_2	mm							EDP Number	★
						ϕD	ϕD_3	L_1	L_2	L_4	C	T		
Softsynchro® Micro	M0.5 - M4 (No.0 - No.8)	2 - 4.5 mm 0.141 - 0.168	ER 8	Hi-Q/ERM 8	10	20	12	43.5	40	1.5	0.2	0.2	F3150G22	★

1) Clamping depths E, see page 624 - 625

Further designs upon request

Clamping nut without integrated seal is included in the delivery

Accessories

- Collets type ER (GB) ▶▶ 610 - 613
- Set of clamping wrenches ▶▶ 621
- Torque wrenches TORCO-FIX ▶▶ 623

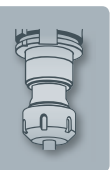

Softsynchro®

Cylindrical Shank

DIN 1835 B+E

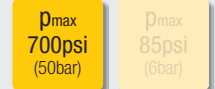
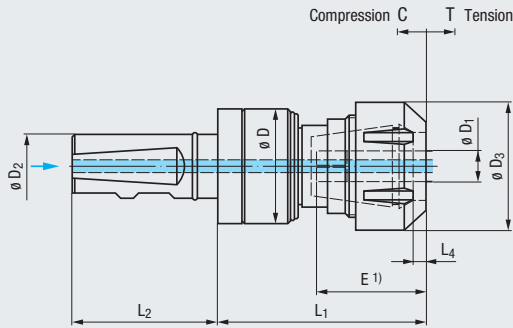

For use on machines with synchronous spindle

Type	Shank Size $\varnothing D_2$	$\varnothing D_1$	ER	Hi-Q/ERM	mm								EDP Number	★	
					$\varnothing D$	$\varnothing D_3$	L_1 ER	L_1 ER-GB	L_2	L_4	C	T			
Softsynchro® 0	M2 - M8 (No.2 - 5/16)	2.5 - 7 mm 0.141 - 0.194	ER 11 (GB)	Hi-Q/ERM 11	16	34	16	72.7	71	49	0.9	0.5	0.5	F3150G24.1.44	★
					20	34	16	72.7	71	51	0.9	0.5	0.5	F3150G25.1.44	★
					25	34	16	72.7	71	57	0.9	0.5	0.5	F3150G26.1.44	★
Softsynchro® 1	M4 - M12 (No.8 - 7/16)	4.5 - 10 mm 0.168 - 0.381	ER 20 (GB)	Hi-Q/ERC 20	20	34	34	-	73	51	5	0.5	0.5	F3151G25.1.44	★
					25	34	34	-	73	57	5	0.5	0.5	F3151G26.1.44	★
Softsynchro® 3	M4 - M20 (1/4 - 3/4)	4.5 - 16 mm 0.255 - 0.590	ER 32 (GB)	Hi-Q/ERC 32	25	45	50	-	87.3	57	5	0.5	0.5	F3153G26.1.44	★
Softsynchro® 4	M12 - M30 (7/16 - 1 1/8)	9 - 22 mm 0.255 - 0.800	ER 40 (GB)	Hi-Q/ERC 40	32	63	63	-	113.5	61	5	0.7	0.7	F3154G27.1	★

1) Clamping depths E, see page 624 - 625

Further designs upon request

Softsynchro® 0

Clamping nut without integrated seal is included in the delivery

Softsynchro® 1-4

Clamping nut for sealing disks is included in the delivery

Accessories



Adapter shanks

▶▶ 604



Collets type ER (GB)

▶▶ 610 - 613



Sealing disks type DS/ER

▶▶ 616



Clamping nut with integrated seal, type Hi-Q/ERM 11

▶▶ 618



Set of clamping wrenches

▶▶ 621



Assembly device

▶▶ 621



Torque wrenches TORCO-FIX

▶▶ 623



Softsynchro®

Weldon Shank

ASME B94.19

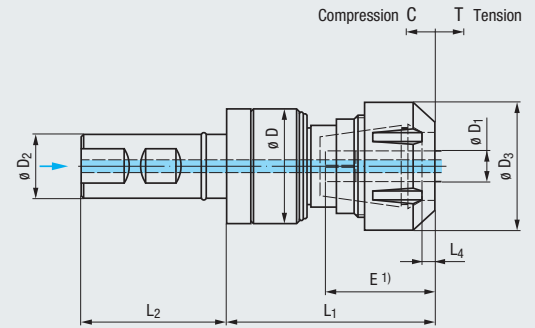
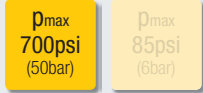

For use on machines with synchronous spindle

Type	Shank Size	inch	Shank Size	inch	inch										EDP Number	
					$\varnothing D_1$	$\varnothing D_2$	$\varnothing D$	$\varnothing D_3$	L_1 ER	L_1 ER-GB	L_2	L_4	C	T		
Softsynchro® 0	M2 - M8 (No.2 - 5/16)	2.5 - 7 mm 0.141 - 0.194	ER 11 (GB)	Hi-Q/ERM 11	1	1.3386	0.6299	2.8622	2.7953	2.2835	0.0354	0.0197	0.0197	F3150H36.1.44	●	
Softsynchro® 1	M4 - M12 (No.8 - 7/16)	4.5 - 10 mm 0.168 - 0.381	ER 20 (GB)	Hi-Q/ERC 20	1	1.3386	1.3386	-	2.8740	2.2835	0.1969	0.0197	0.0197	F3151H36.1.44	●	
Softsynchro® 3	M4 - M20 (1/4 - 3/4)	4.5 - 16 mm 0.255 - 0.590	ER 32 (GB)	Hi-Q/ERC 32	1	1.7717	1.9685	-	3.4370	2.2835	0.1969	0.0197	0.0197	F3153H36.1.44	●	
Softsynchro® 4	M12 - M30 (7/16 - 1 1/8)	9 - 22 mm 0.255 - 0.800	ER 40 (GB)	Hi-Q/ERC 40	1 1/4	2.4803	2.4803	-	4.4685	2.2835	0.1969	0.0276	0.0276	F3154H38.1	●	

1) Clamping depths E, see page 624 - 625

Further designs upon request

Softsynchro® 0

Clamping nut without integrated seal is included in the delivery

Softsynchro® 1-4

Clamping nut for sealing disks is included in the delivery

Accessories

	Adapter shanks	» 604		Set of clamping wrenches	» 621
	Collets type ER (GB)	» 610 - 613		Assembly device	» 621
	Sealing disks type DS/ER	» 616		Torque wrenches TORCO-FIX	» 623
	Clamping nut with integrated seal, type Hi-Q/ERM 11	» 618			



Softsynchro®

Cylindrical Shank

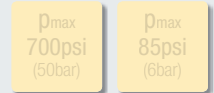
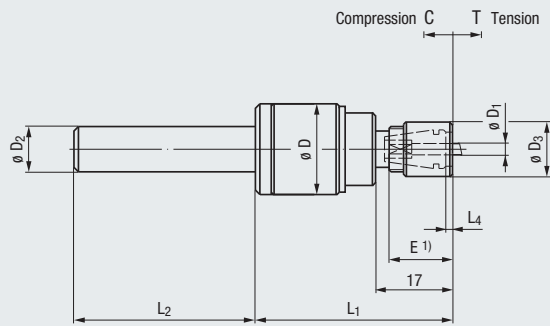
DIN 1835 A



For use on machines
with synchronous spindle

Type		$\varnothing D_1$			Shank Size $\varnothing D_2$ h6	$\varnothing D$	$\varnothing D_3$	L_1	L_2	L_4	C	T	EDP Number	
Softsynchro® Micro	M0.5 - M4 (No.0 - No.8)	2 - 4.5 mm 0-141 - 0.168	ER 8	Hi-Q/ERM 8	10	20	12	43.5	40	1.5	0.2	0.2	F3150900	★

1) Clamping depths E, see page 624 - 625

Further designs upon request

Clamping nut without integrated seal is included in the delivery

Accessories



Collets type ER (GB)

» 610 - 613



Set of clamping wrenches

» 621



Torque wrenches TORCO-FIX

» 623



Long design

Softsynchro®

Cylindrical Shank

≈ DIN 1835 A

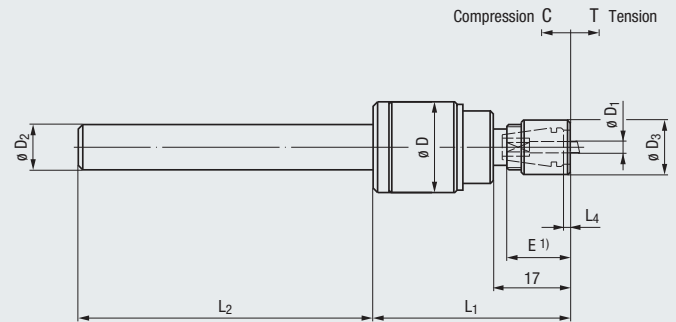
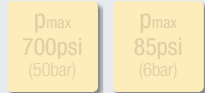

For use on machines with synchronous spindle

Type		ϕD_1			Shank Size ϕD_2 h6	mm							EDP Number	★
						ϕD	ϕD_3	L_1	L_2	L_4	C	T		
Softsynchro® Micro	M0.5 - M4 (No.0 - No.8)	2 - 4.5 mm 0.141 - 0.168	ER 8	Hi-Q/ERM 8	10	20	12	43.5	66	1.5	0.2	0.2	F3150901	★

1) Clamping depths E, see page 624 - 625

Further designs upon request

Clamping nut without integrated seal is included in the delivery

Accessories



Collets type ER (GB)

▶▶ 610 - 613



Set of clamping wrenches

▶▶ 621



Torque wrenches TORCO-FIX

▶▶ 623



Softsynchro®

CAT Shank

ASME B5.50
UNC drawbolt thread

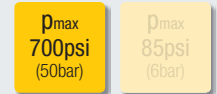
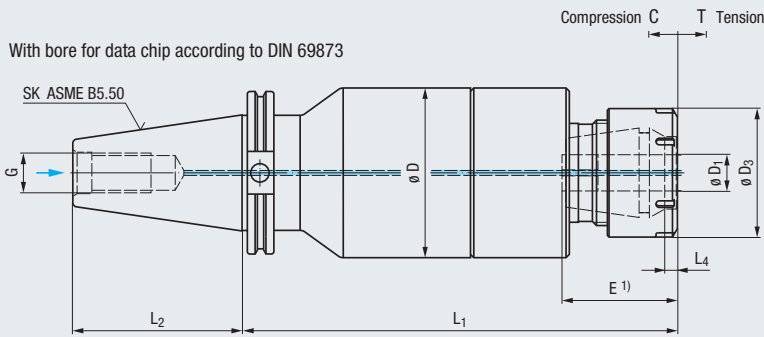
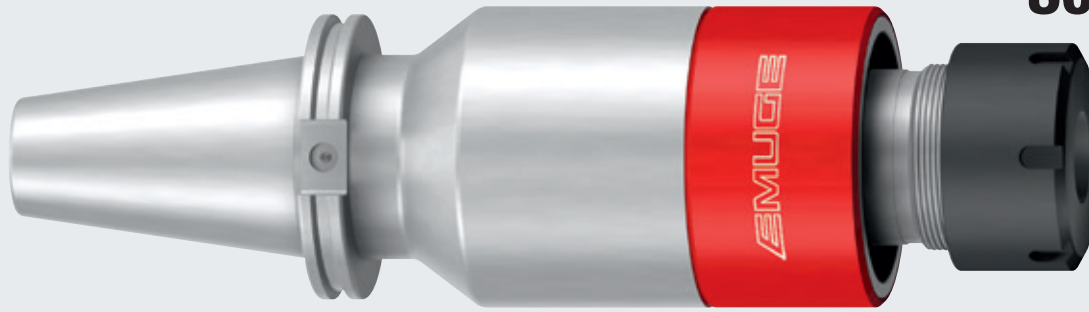

For use on machines
with synchronous spindle

Type		ø D ₁			Shank Size	mm							G	C	T	EDP Number	★
						ø D	ø D ₃	L ₁ ER	L ₁ ER-GB	L ₂	L ₄						
Softsynchro® 5	M30 - M48 (1 - 1 1/2)	22 - 36 mm 0.800 - 1.233	ER 50 (GB)	Hi-Q/ERBC 50	CAT 50	3.0709	4.0551	10.5315	10.3937	4.0000	0.3150	1 - 8	0.0787	0.0787	F3155783.1.16	★	

1) Clamping depths E, see page 624 - 625

Further designs upon request

Clamping nut for sealing disks is included in the delivery

Square seat for tools with shank diameter 36 mm is integrated in the tap holder body

Accessories



Collets type ER (GB) ▶▶ 610 - 613



Sealing disks type DS/ER ▶▶ 616



Clamping wrenches ▶▶ 621



Torque wrenches TORCO-FIX ▶▶ 623



Softsynchro®

SK Shank

DIN 69871 AD

DIN 69871 B



For use on machines with synchronous spindle

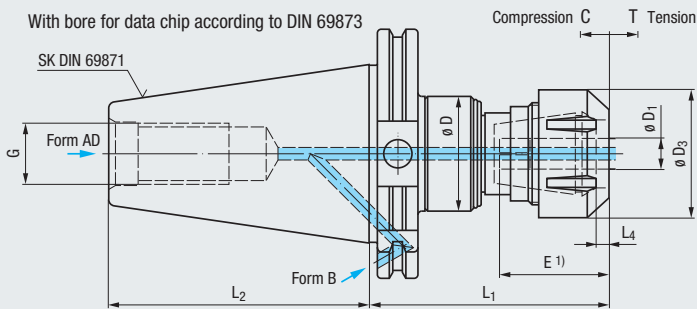

new	Type	Ø D ₁	ER	Hi-Q/ERC	Shank Size	mm							EDP Number	★	
						Ø D	Ø D ₃	L ₁	L ₂	L ₄	G	C			T
Softsynchro® 1	M4 - M12 (No.8 - 7/16)	4.5 - 10 mm 0.168 - 0.381	ER 20 (GB)	Hi-Q/ERC 20	SK 40 AD	34	34	85	68.4	5	M16	0.5	0.5	F3151651.1	★
					SK 40 B	34	34	85	68.4	5	M16	0.5	0.5	F3151651.2	★
					SK 50 AD	34	34	85	101.75	5	M24	0.5	0.5	F3151653.1	★
					SK 50 B	34	34	85	101.75	5	M24	0.5	0.5	F3151653.2	★
Softsynchro® 3	M4 - M20 (1/4 - 3/4)	4.5 - 16 mm 0.255 - 0.590	ER 32 (GB)	Hi-Q/ERC 32	SK 40 AD	45	50	93.5	68.4	5	M16	0.5	0.5	F3153651.1	★
					SK 40 B	45	50	93.5	68.4	5	M16	0.5	0.5	F3153651.2	★
					SK 50 AD	45	50	93.5	101.75	5	M24	0.5	0.5	F3153653.1	★
					SK 50 B	45	50	93.5	101.75	5	M24	0.5	0.5	F3153653.2	★

1) Clamping depths E, see page 624 - 625

Further designs upon request

Clamping nut for sealing disks is included in the delivery

Accessories



Collets type ER (GB)

▶▶ 610 - 613



Sealing disks type DS/ER

▶▶ 616



Set of clamping wrenches

▶▶ 621



Assembly device

▶▶ 621



Torque wrenches TORCO-FIX

▶▶ 623

Softsynchro®

SK Shank
DIN 69871 AD
DIN 69871 B

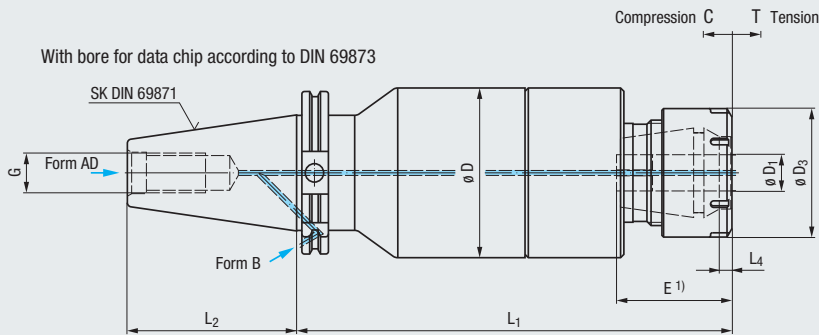
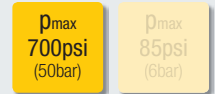
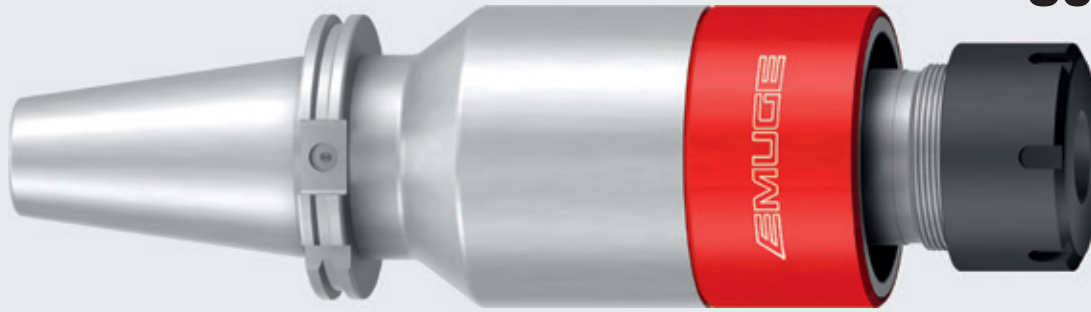

For use on machines with synchronous spindle

new Type	Image	Ø D ₁	Image	Image	Shank Size	mm										EDP Number	★
						Ø D	Ø D ₃	L ₁ ER	L ₁ ER-GB	L ₂	L ₄	G	C	T			
Softsynchro® 5	M30 - M48 (1 - 1 1/2)	22 - 36 mm 0.800 - 1.233	ER 50 (GB)	Hi-Q/ERBC 50	SK 50 AD SK 50 B	103	78	267.5	264	101.75	8	M24	2	2	F3155653.1	★	
						103	78	267.5	264	101.75	8	M24	2	2	F3155653.2		

1) Clamping depths E, see page 624 - 625

Further designs upon request

Clamping nut for sealing disks is included in the delivery

Square seat for tools with shank diameter 36 mm is integrated in the tap holder body

Accessories



Collets type ER (GB) ▶▶ 610 - 613



Sealing disks type DS/ER ▶▶ 616



Clamping wrenches ▶▶ 621



Torque wrenches TORCO-FIX ▶▶ 623



- Product Finder
- Soft-synchro
- Speed-synchro
- KSN
- MQL
- SFM
- HF
- EM
- Accessories
- Tech. Info

Softsynchro®

SK Shank
DIN 69871 AD

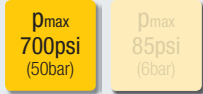

For use on machines with synchronous spindle

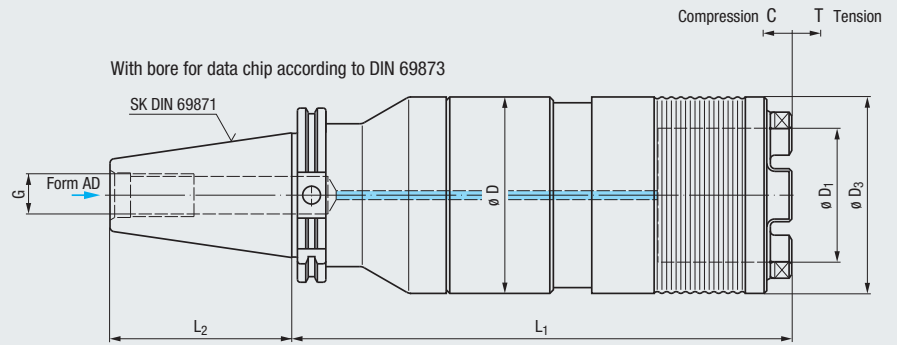

Type			Shank Size	mm									EDP Number	★
				∅ D	∅ D ₁	∅ D ₃	L ₁	L ₂	G	C	T			
Softsynchro® 6	M45 - M76 (1 3/8 - 2 3/8)	HE2/IKZZ	SK 50 AD	110	75	110	280	101.75	M24	2	2	F3156653.1		

Further designs upon request

Accessories



Quick-change adapters type HE2/IKZZ ➔ 578 - 579

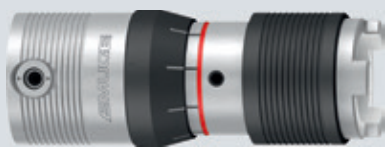
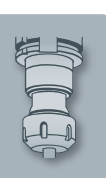

Further quick-change tap holders (HF series) for the production of large threads, see pages 576

Softsynchro®

BT Shank

JIS B 6339 (MAS 403 BT)

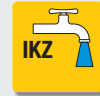
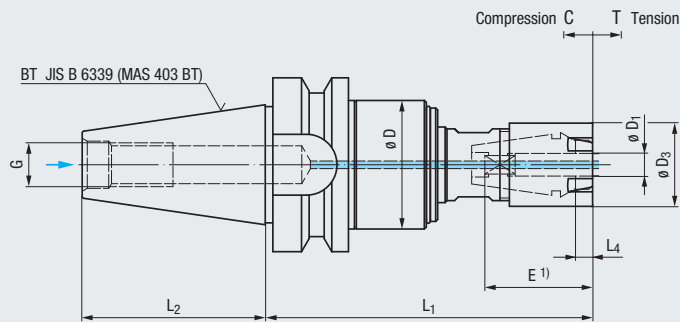
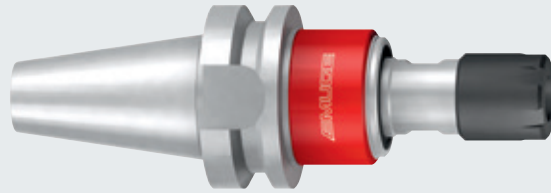

p_{max}
700psi
(50bar)

p_{max}
85psi
(6bar)



For use on machines
with synchronous spindle

Type		$\varnothing D_1$			Shank Size	inch							EDP Number		
						$\varnothing D$	$\varnothing D_3$	L_1	L_2	L_4	G	C			T
Softsynchro® 1	M4 - M12	4.5 - 10 mm	ER 16 (GB)	Hi-Q/ERMC 16	BT 30	1.3386	0.8661	3.4055	1.9055	0.1969	M12	0.0197	0.0197	F3151049.1	★

1) Clamping depths E, see page 624 - 625

Further designs upon request

Clamping nut for sealing disks is included in the delivery

Accessories



Collets type ER (GB) ▶▶ 610 - 613



Sealing disks type DS/ER ▶▶ 616



Set of clamping wrenches ▶▶ 621



Assembly device ▶▶ 621



Torque wrenches TORCO-FIX ▶▶ 623



Softsynchro[®] mimatic[®]



Compression C T Tension

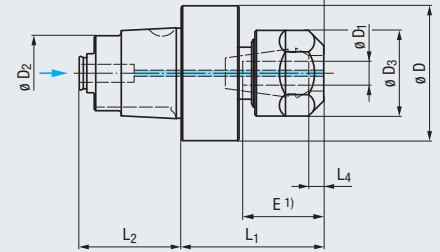

For use on machines
with synchronous spindle

Type	Image	$\varnothing D_1$	Image	Image	Image	mm								C	T	EDP Number	★
						$\varnothing D_2$	$\varnothing D$	$\varnothing D_3$	L_1 ER	L_1 ER-GB	L_2	L_4					
Softsynchro [®] 1	M4 - M12	4.5 - 10 mm	ER 16 (GB)	Hi-Q/ERC 16	MI 40	25	45	28	51	47.5	34	5	0.5	0.5	F3151Z40.M01001	★	
					MI 50	33	55	28	48	44.5	41	5	0.5	0.5	F3151Z50.M01001	★	

1) Clamping depths E, see page 624 - 625

Further designs upon request

Clamping nut for sealing disks is included in the delivery

Square seat for tools with shank diameter 9 and 10 mm is integrated in the tap holder body

Accessories



Collets type ER (GB)

▶▶ 610 - 613



Sealing disks type DS/ER

▶▶ 616



Set of clamping wrenches

▶▶ 621



Torque wrenches TORCO-FIX

▶▶ 623

For driven tools

Softsynchro®
heimatec®

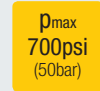
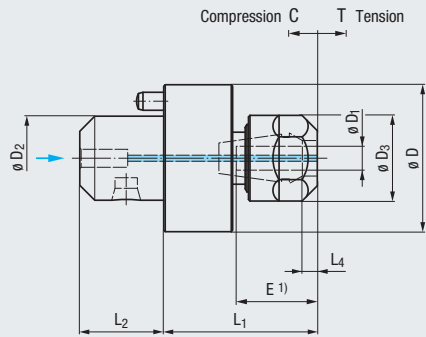
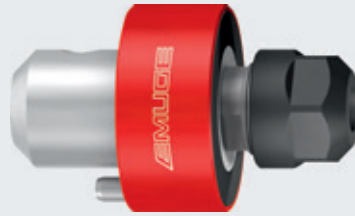

For use on machines with synchronous spindle

Type	Image	$\varnothing D_1$	Image	Image	Image	mm								C	T	EDP Number	★
						$\varnothing D_2$	$\varnothing D$	$\varnothing D_3$	L_1 ER	L_1 ER-GB	L_2	L_4					
Softsynchro® 1	M4 - M12	4.5 - 10 mm	ER 16 (GB)	Hi-Q/ERC 16	HT4	22	39	28	55	51.5	21.5	5	0.5	0.5	F3151Z04.H01001	★	
					HT5	28	49	28	55	51.5	28	5	0.5	0.5	F3151Z05.H01001	★	
					HT6	36	64	28	48	44.5	28	5	0.5	0.5	F3151Z06.H01001	★	

1) Clamping depths E, see page 624 - 625

Further designs upon request

Clamping nut for sealing disks is included in the delivery

Square seat for tools with shank diameter 9 and 10 mm is integrated in the tap holder body

Accessories



Collets type ER (GB) ▶▶ 610 - 613



Sealing disks type DS/ER ▶▶ 616



Set of clamping wrenches ▶▶ 621



Torque wrenches TORCO-FIX ▶▶ 623

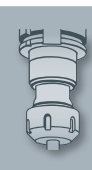





Softsynchro® W&F

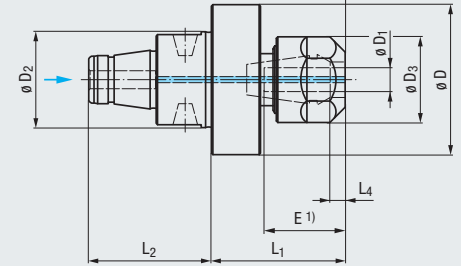

Compression C T Tension



For use on machines with synchronous spindle

Type		$\varnothing D_1$				mm								C	T	EDP Number	★
						$\varnothing D_2$	$\varnothing D$	$\varnothing D_3$	L_1 ER	L_1 ER-GB	L_2	L_4					
Softsynchro® 1	M4 - M12	4.5 - 10 mm	ER 16 (GB)	Hi-Q/ERC 16	WFB 32-20	32	50	28	48	44.5	41	5	0.5	0.5	F3151Z32.W01001	★	
					WFB 40-25	40	63	28	48	44.5	46	5	0.5	0.5	F3151Z40.W01001	★	
					WFB 50-32	48	75	28	48	44.5	54	5	0.5	0.5	F3151Z50.W01001	★	

1) Clamping depths E, see page 624 - 625

Further designs upon request

Clamping nut for sealing disks is included in the delivery

Square seat for tools with shank diameter 9 and 10 mm is integrated in the tap holder body

Accessories



Collets type ER (GB)

►► 610 - 613



Sealing disks type DS/ER

►► 616



Set of clamping wrenches

►► 621



Torque wrenches TORCO-FIX

►► 623

Softsynchro®/PGR

HSK-A Shank

DIN 69893 A

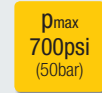
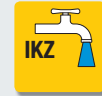
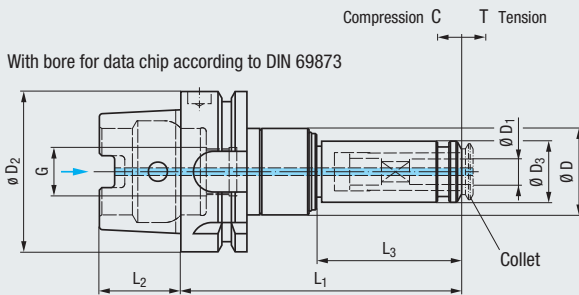
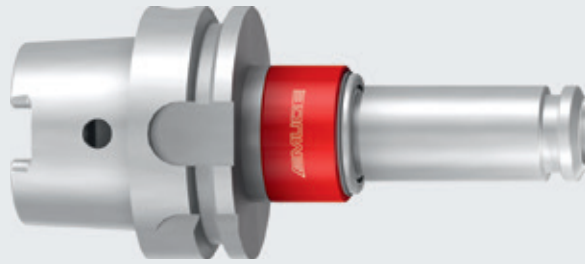

For use on machines with synchronous spindle

Type	Image	ϕD_1	Image	Shank Size ϕD_2	mm								EDP Number	
					ϕD	ϕD_3	L_1	L_2	L_3	G	C	T		
Softsynchro® 1/PGR	M4 - M12 (No.10 - 1/4)	4.5 - 10 mm 0.194 - 0.255	PGR 15 GB	HSK-A50	34	24	108	25	57	M16 x 1	0.5	0.5	F3221C03.1	
				HSK-A63	34	24	110	32	57	M18 x 1	0.5	0.5	F3221C04.1	★
				HSK-A80	34	24	114.5	40	57	M20 x 1.5	0.5	0.5	F3221C05.1	
				HSK-A100	34	24	116.5	50	57	M24 x 1.5	0.5	0.5	F3221C06.1	★
Softsynchro® 3/PGR	M8 - M20 (1/4 - 3/4)	8 - 16 mm 0.255 - 0.590	PGR 25 GB	HSK-A50	45	40	132.5	25	67	M16 x 1	0.5	0.5	F3223C03.1	
				HSK-A63	45	40	125	32	67	M18 x 1	0.5	0.5	F3223C04.1	★
				HSK-A80	45	40	129.5	40	67	M20 x 1.5	0.5	0.5	F3223C05.1	★
				HSK-A100	45	40	131.5	50	67	M24 x 1.5	0.5	0.5	F3223C06.1	★

Further designs upon request

Accessories



Collets type PGR-GB

▶▶ 630



Coolant tubes and wrenches

▶▶ 606 - 607



- Product Finder
- Soft-synchro
- Speed-synchro
- KSN
- MQL
- SFM
- HF
- EM
- Accessories
- Tech. Info

Softsynchro®/PGR

Cylindrical Shank

DIN 1835 B+E



IKZ

MQL

Ø_{max}
700psi
(50bar)

Ø_{max}
85psi
(6bar)

C T
Soft

F

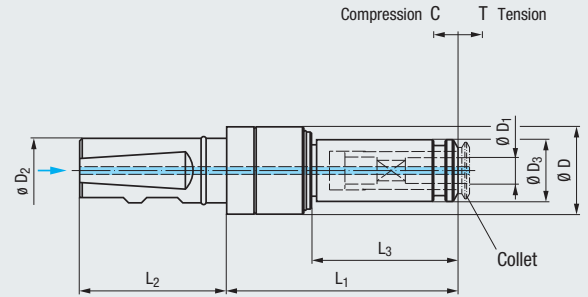

For use on machines with synchronous spindle

Type	Image	Ø D ₁	Image	Ø D ₂	mm							EDP Number	★
					Ø D	Ø D ₃	L ₁	L ₂	L ₃	C	T		
Softsynchro® 1/PGR	M4 - M12 (No.10 - 1/4)	4.5 - 10 mm 0.194 - 0.255	PGR 15 GB	25	34	24	87.5	57	57	0.5	0.5	F3221G26.1.44	★
Softsynchro® 3/PGR	M8 - M20 (1/4 - 3/4)	8 - 16 mm 0.255 - 0.590	PGR 25 GB	25	45	40	103.5	57	67	0.5	0.5	F3223G26.1.44	★

Further designs upon request

Accessories

- Collets type PGR-GB
▶▶ 630
- Adapter shanks
▶▶ 604

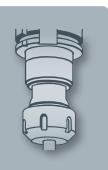

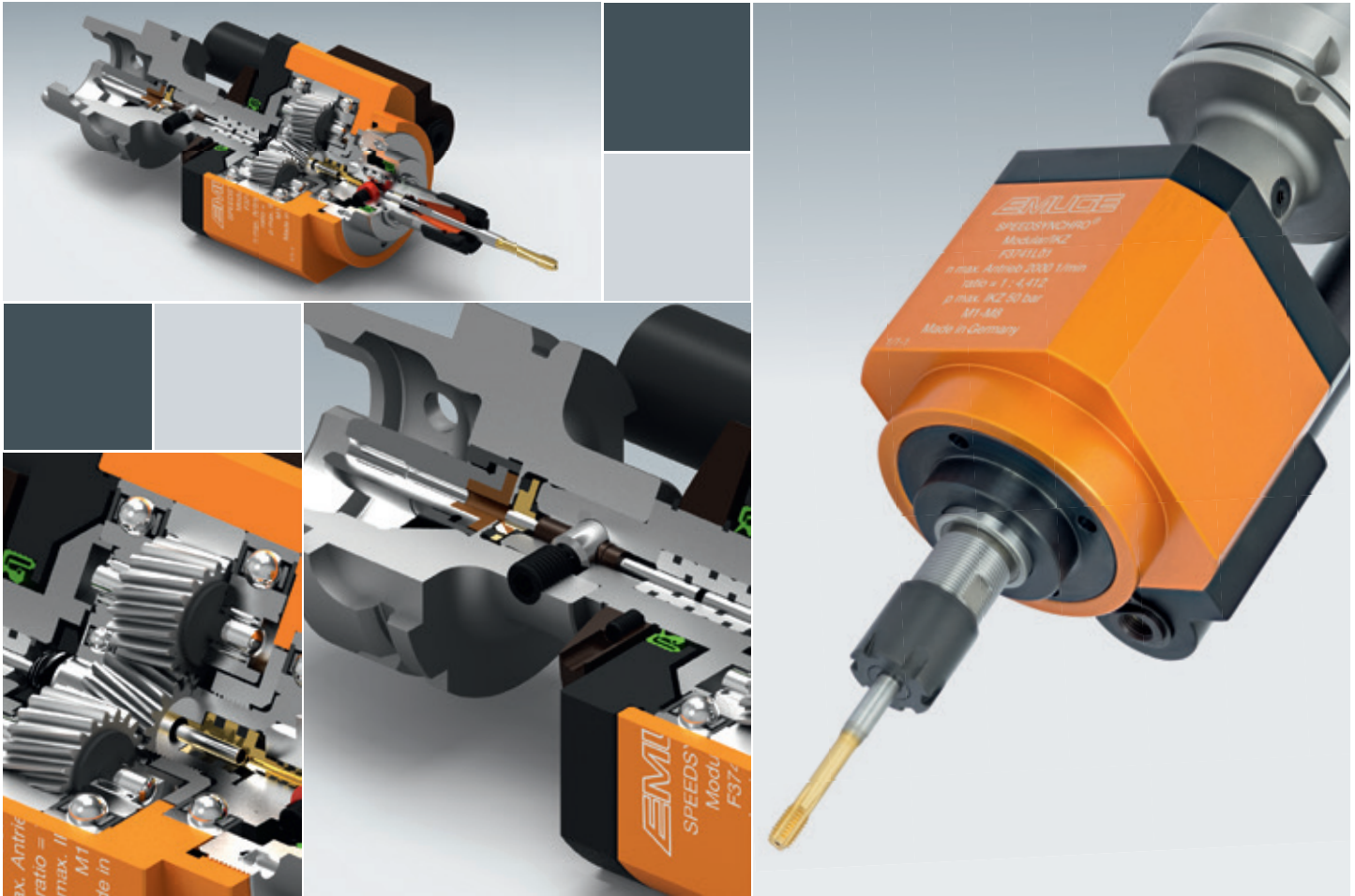

Speedsynchro® Modular Series

Softsynchro® technology with transmission gearing

The Speedsynchro® Modular uses an integrated transmission gearing with a transmission ratio of 1:4.412 and combines it with the patented Softsynchro® minimal length compensation function.

For achieving a high tool speed at a low spindle speed in order to reduce cycle time, save energy, reduce axial force and increase efficiency.



Speedsynchro® Modular/IKZ

Cylindrical Shank

DIN 1835 B

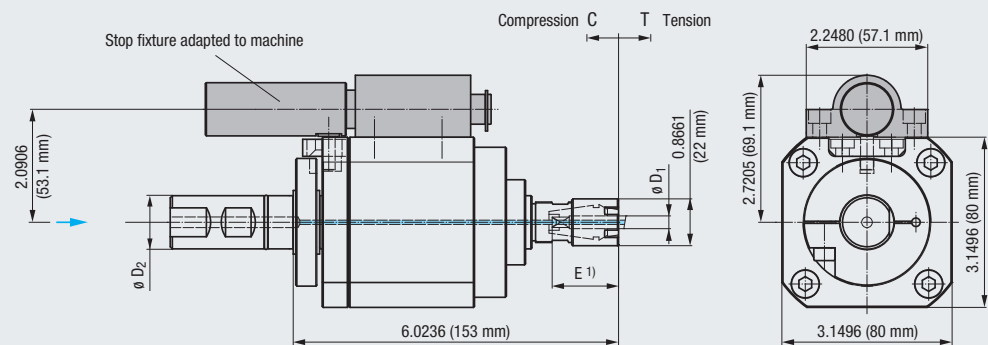

For use on machines with synchronous spindle

new	Type	mm				Max. Spindle Speed	Transmission Ratio	mm		EDP Number
		$\varnothing D_2$	$\varnothing D_1$	C	T					
	M1 - M8	ER 16 (GB)	Hi-Q/ERMC 16	25	2.5 - 8	2000	1:4.412	0.5	0.5	F3741G26

1) Clamping depths E, see page 624 - 625

Adapter shank, stop fixture (see also page 646) and length adjustment screw are not included in the delivery, please order separately

Accessories

-  Adapter shanks ▶ 604
-  Assembly device ▶ 621
-  Collets type ER (GB) ▶ 610 - 613
-  Length adjustment screws ▶ 609
-  Sealing disks type DS/ER ▶ 616



More information regarding Speedsynchro® Modular at www.speedsynchro.com

Speedsynchro® Modular/IKZ

ABS® Shank

ABS®-clutch (System KOMET)



EMUGE
SPEEDSYNCHRO®
Modular/IKZ
F-374 1L 01
n max. Antrieb 2000 1/min
ratio = 1 : 4,412
p max. IKZ 50 bar
M1-M8
Made in Germany

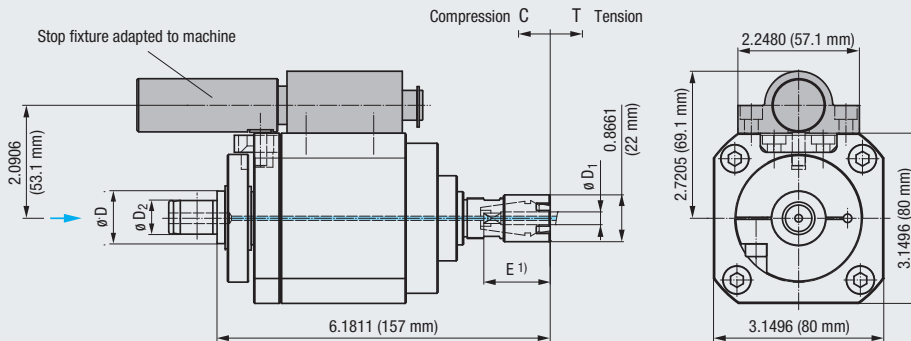

-
-
- p_{max} 700psi (50bar)
- p_{max} 140psi (10bar)
- L+ 2 mm
-
-
-
-
-
-

For use on machines with synchronous spindle

new				mm			Max. Spindle Speed	Transmission Ratio	mm		EDP Number	
	Type			$\varnothing D$	$\varnothing D_2$	$\varnothing D_1$			C	T		
Speedsynchro® Modular/IKZ	M1 - M8	ER 16 (GB)	Hi-Q/ERMC 16	ABS 32	16	2.5 - 8	2000	1:4.412	0.5	0.5	F3741L01	●

1) Clamping depths E, see page 624 - 625

Adapter shank, stop fixture (see also page 646) and length adjustment screw are not included in the delivery, please order separately

Accessories

- Adapter shanks ▶▶ 605
- Assembly device ▶▶ 621
- Collets type ER (GB) ▶▶ 610 - 613
- Length adjustment screws ▶▶ 609
- Sealing disks type DS/ER ▶▶ 616

Product Finder

- Soft-synchro
- Speed-synchro
- KSN
- MQL
- SFM
- HF
- EM
- Accessories
- Tech. Info

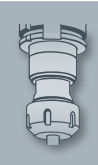

Speedsynchro® Modular/MQL

ABS® Shank

ABS®-clutch (System KOMET)

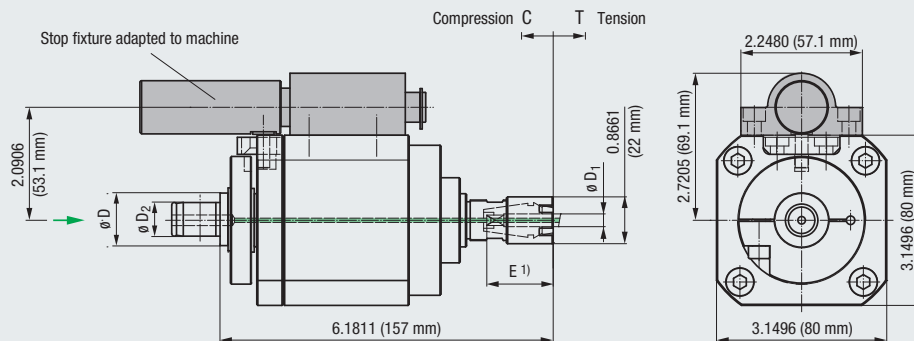
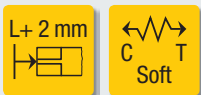
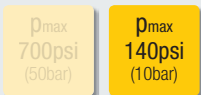

For use on machines with synchronous spindle

new	Type	M1 - M8	ER 16 (GB)	Hi-Q/ERMC 16	mm			Max. Spindle Speed	Transmission Ratio	mm		EDP Number	
					ø D	ø D ₂	ø D ₁			C	T		
	Speedsynchro® Modular/MQL	M1 - M8	ER 16 (GB)	Hi-Q/ERMC 16	ABS 32	16	2.5 - 8	2000	1:4.412	0.5	0.5	F3751L01	●

1) Clamping depths E, see page 624 - 625

Adapter shank, stop fixture (see also page 646) and length adjustment screw are not included in the delivery, please order separately

Accessories



Adapter shanks

» 605



Assembly device

» 621



Collets type ER (GB)

» 610 - 613



Length adjustment screws

» 609



Sealing disks type DS/ER

» 616



KSN Series

Application on CNC machining centers and conventional machine tools

The accuracy of the programmed thread depth is guaranteed by a patent-protected pressure point mechanism. Arising differences between spindle feed and thread pitch are compensated by a length compensation.



KSN

HSK-A Shank

DIN 69893 A

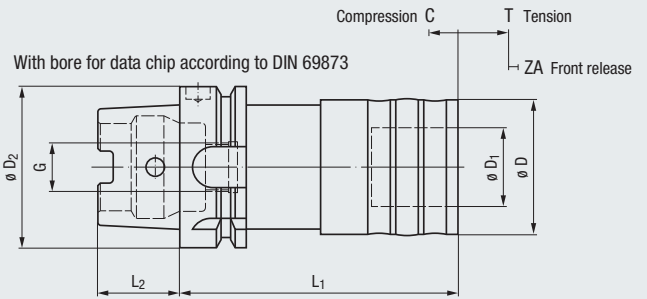
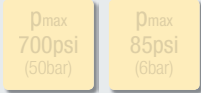
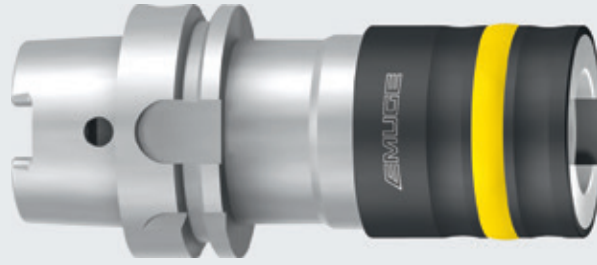

For use on CNC machining centers, other machine tools and pillar drilling machines

Type	Image	Image	Shank Size $\varnothing D_2$	mm								EDP Number	★
				$\varnothing D$	$\varnothing D_1$	L_1	L_2	G	C	T	ZA		
KSN 1	M3 - M14 (No.0 - 9/16)	EM 01	HSK-A32	36	19	71	16	M10 x 1	5	8	2.1	F3301C01.30	★
			HSK-A40	36	19	73	20	M12 x 1	5	8	2.1	F3301C02.30	★
			HSK-A50	36	19	77	25	M16 x 1	5	8	2.1	F3301C03.30	★
			HSK-A63	36	19	79	32	M18 x 1	5	8	2.1	F3301C04.30	★
			HSK-A80	36	19	83.5	40	M20 x 1.5	5	8	2.1	F3301C05.30	★
			HSK-A100	36	19	85.5	50	M24 x 1.5	5	8	2.1	F3301C06.30	★
KSN 3	M4.5 - M24 (1/4 - 7/8)	EM 03	HSK-A40	53	31	107	20	M12 x 1	8.5	15	2.8	F3303C02.30	★
			HSK-A50	53	31	111	25	M16 x 1	8.5	15	2.8	F3303C03.30	★
			HSK-A63	53	31	113	32	M18 x 1	8.5	15	2.8	F3303C04.30	★
			HSK-A80	53	31	117.5	40	M20 x 1.5	8.5	15	2.8	F3303C05.30	★
			HSK-A100	53	31	119.5	50	M24 x 1.5	8.5	15	2.8	F3303C06.30	★
KSN 4	M14 - M36 (5/8 - 1 3/8)	EM 04	HSK-A63	78	48	164	32	M18 x 1	15	23.5	4.1	F3304C04.30	★
			HSK-A80	78	48	168.5	40	M20 x 1.5	15	23.5	4.1	F3304C05.30	★
			HSK-A100	78	48	170.5	50	M24 x 1.5	15	23.5	4.1	F3304C06.30	★
KSN 5	M22 - M48 (7/8 - 1 7/8)	EM 05	HSK-A80	96	60	203	40	M20 x 1.5	16.5	25	5.7	F3305C05.30	★
			HSK-A100	96	60	205	50	M24 x 1.5	16.5	25	5.7	F3305C06.30	★

Further designs upon request

Accessories



Quick-change adapters EM series ▶▶ 583 - 601



Coolant tubes and wrenches ▶▶ 606 - 607

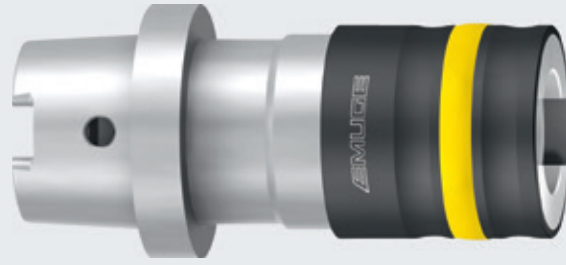

KSN
HSK-C Shank
DIN 69893 C

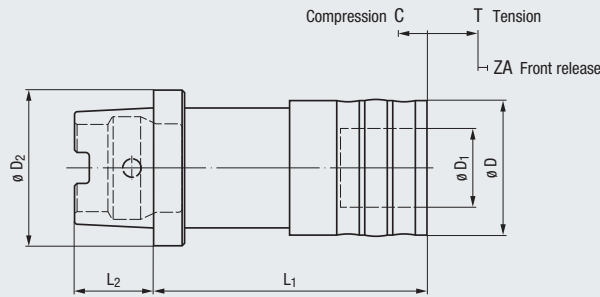
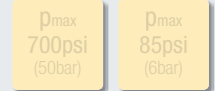

For use on CNC machining centers,
other machine tools and pillar drilling machines

Type			Shank Size $\varnothing D_2$	$\varnothing D$	$\varnothing D_1$	L_1	L_2	C	T	ZA	EDP Number	
KSN 1	M3 - M14 (No.0 - 9/16)	EM 01	HSK-C32	36	19	65	16	5	8	2.1	F3301K01.30	★
			HSK-C40	36	19	65	20	5	8	2.1	F3301K02.30	★
			HSK-C50	36	19	67	25	5	8	2.1	F3301K03.30	★
			HSK-C63	36	19	67	32	5	8	2.1	F3301K04.30	★
			HSK-C80	36	19	70	40	5	8	2.1	F3301K05.30	
KSN 3	M4.5 - M24 (1/4 - 7/8)	EM 03	HSK-C40	53	31	99	20	8.5	15	2.8	F3303K02.30	★
			HSK-C50	53	31	101	25	8.5	15	2.8	F3303K03.30	★
			HSK-C63	53	31	101	32	8.5	15	2.8	F3303K04.30	★
			HSK-C80	53	31	104	40	8.5	15	2.8	F3303K05.30	
			HSK-C100	53	31	104	50	8.5	15	2.8	F3303K06.30	
KSN 4	M14 - M36 (5/8 - 1 3/8)	EM 04	HSK-C63	78	48	152	32	15	23.5	4.1	F3304K04.30	★
			HSK-C80	78	48	155	40	15	23.5	4.1	F3304K05.30	
			HSK-C100	78	48	155	50	15	23.5	4.1	F3304K06.30	
KSN 5	M22 - M48 (7/8 - 1 7/8)	EM 05	HSK-C80	96	60	189	40	16.5	25	5.7	F3305K05.30	
			HSK-C100	96	60	189	50	16.5	25	5.7	F3305K06.30	

Further designs upon request

Accessories



Quick-change adapters EM series ▶▶ 583 - 601



- Product Finder
- Soft-synchro
- Speed-synchro
- KSN**
- MQL
- SFM
- HF
- EM
- Accessories
- Tech. Info

KSN

Cylindrical Shank

DIN 1835 B+E

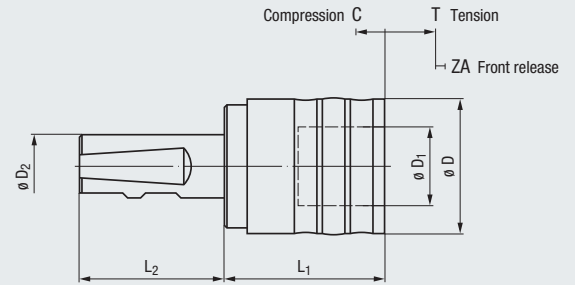
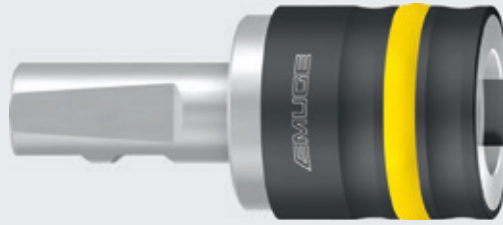

For use on CNC machining centers, other machine tools and pillar drilling machines

Type			Shank Size $\varnothing D_2$	$\varnothing D$	$\varnothing D_1$	L_1	L_2	C	T	ZA	EDP Number	
KSN 0	M1 - M10 (No.0 - 1/4)	EM 00	16	26	13	38	49	5	7.5	1.7	F3300G24	★
			20	26	13	38	51	5	7.5	1.7	F3300G25	★
KSN 1	M3 - M14 (No.0 - 9/16)	EM 01	16	36	19	39	49	5	8	2.1	F3301G24	★
			20	36	19	39	51	5	8	2.1	F3301G25	★
			25	36	19	39	57	5	8	2.1	F3301G26	★
KSN 3	M4.5 - M24 (1/4 - 7/8)	EM 03	25	53	31	63	57	8.5	15	2.8	F3303G26	★
			32	53	31	63	61	8.5	15	2.8	F3303G27	★
KSN 4	M14 - M36 (5/8 - 1 3/8)	EM 04	32	78	48	124	61	15	23.5	4.1	F3304G27	★
KSN 5	M22 - M48 (7/8 - 1 7/8)	EM 05	40	96	60	135.5	71	16.5	25	5.7	F3305G28	★

Further designs upon request

Accessories



Quick-change adapters EM series ▶▶ 583 - 601



Adapter shanks ▶▶ 604

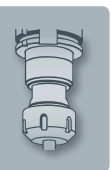

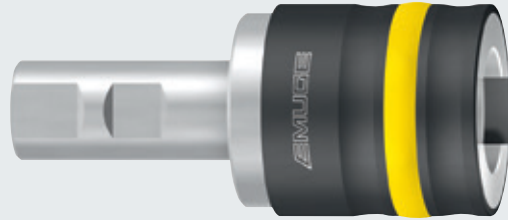

KSN
Weldon Shank
ASME B94.19

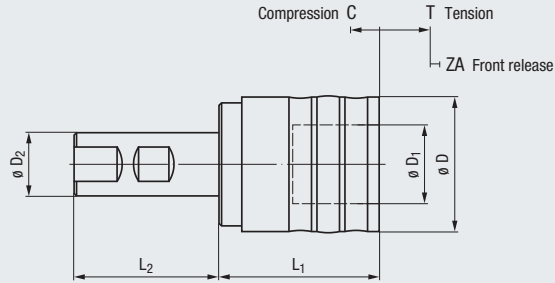
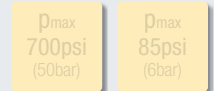

For use on CNC machining centers,
other machine tools and pillar drilling machines

Type	Shank Size ø D ₂	inch	ø D	ø D ₁	L ₁	L ₂	C	T	ZA	EDP Number		
KSN 1	M3 - M14 (No.0 - 9/16)	EM 01	1	1.4173	0.7480	1.5354	2.2835	0.1969	0.3150	0.0827	F3301H36	●
			1 1/4	1.4173	0.7480	1.5354	2.2835	0.1969	0.3150	0.0827	F3301H38	●
KSN 3	M4.5 - M24 (1/4 - 7/8)	EM 03	1 1/4	2.0866	1.2205	2.4803	2.2835	0.3346	0.5906	0.1102	F3303H38	●
			1 1/2	2.0866	1.2205	2.4803	2.6890	0.3346	0.5906	0.1102	F3303H40	●
KSN 4	M14 - M36 (5/8 - 1 3/8)	EM 04	1 1/2	3.0709	1.8898	4.8819	2.6890	0.5906	0.9252	0.1614	F3304H40	●
KSN 5	M22 - M48 (7/8 - 1 7/8)	EM 05	1 1/2	3.7795	2.3622	5.3346	2.6890	0.6496	0.9843	0.2244	F3305H40	●

Further designs upon request

Accessories



Quick-change adapters EM series ▶▶ 583 - 601



Adapter shanks ▶▶ 604

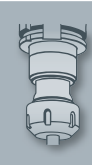

- Product Finder
- Soft-synchro
- Speed-synchro
- KSN**
- MQL
- SFM
- HF
- EM
- Accessories
- Tech. Info

KSN SK Shank DIN 69871 A

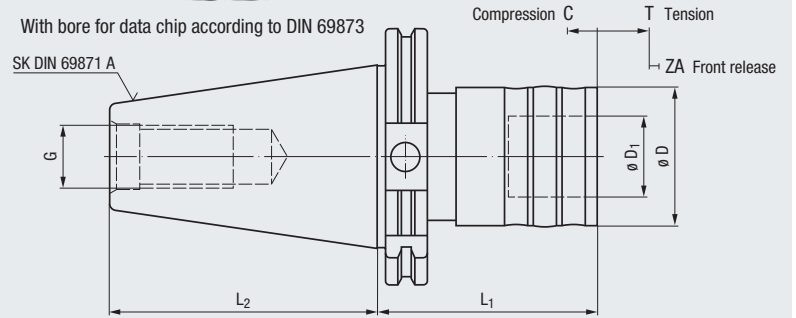
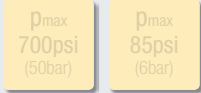

For use on CNC machining centers,
other machine tools and pillar drilling machines

Type	Image	Image	Shank Size	mm								EDP Number	★
				ø D	ø D ₁	L ₁	L ₂	G	C	T	ZA		
KSN 1	M3 - M14 (No.0 - 9/16)	EM 01	SK 40	36	19	60	68.4	M16	5	8	2.1	F3301651	★
			SK 50	36	19	60	101.75	M24	5	8	2.1	F3301653	★
KSN 3	M4.5 - M24 (1/4 - 7/8)	EM 03	SK 40	53	31	98	68.4	M16	8.5	15	2.8	F3303651	★
			SK 50	53	31	84	101.75	M24	8.5	15	2.8	F3303653	★
KSN 4	M14 - M36 (5/8 - 1 3/8)	EM 04	SK 40	78	48	150	68.4	M16	15	23.5	4.1	F3304651	★
			SK 50	78	48	139	101.75	M24	15	23.5	4.1	F3304653	★
KSN 5	M22 - M48 (7/8 - 1 7/8)	EM 05	SK 40	96	60	166	68.4	M16	16.5	25	5.7	F3305651	★
			SK 50	96	60	153	101.75	M24	16.5	25	5.7	F3305653	★

Further designs upon request

Accessories



Quick-change adapters EM series ▶▶ 583 - 601

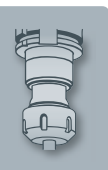



KSN

SK Shank

ASME B5.50, Metric drawbolt thread

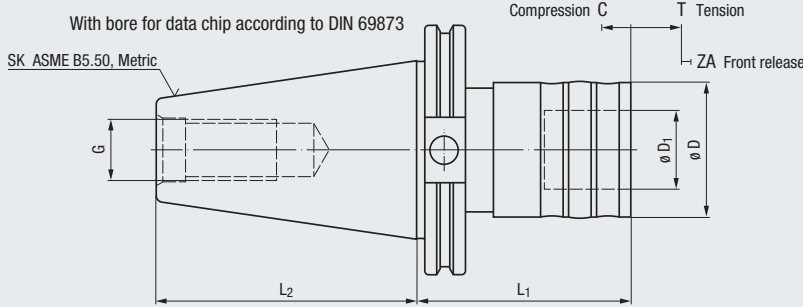
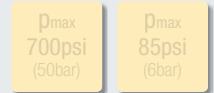

For use on CNC machining centers, other machine tools and pillar drilling machines

Type	Tap	Adapter	Shank Size	mm								EDP Number	
				ø D	ø D ₁	L ₁	L ₂	G	C	T	ZA		
KSN 1	M3 - M14 (No.0 - 9/16)	EM 01	SK 40 ¹⁾	36	19	74	68.25	M16	5	8	2.1	F3301781	★
			SK 50 ¹⁾	36	19	74	101.60	M24	5	8	2.1	F3301783	★
KSN 3	M4.5 - M24 (1/4 - 7/8)	EM 03	SK 40 ¹⁾	53	31	98	68.25	M16	8.5	15	2.8	F3303781	★
			SK 50 ¹⁾	53	31	99	101.60	M24	8.5	15	2.8	F3303783	★
KSN 4	M14 - M36 (5/8 - 1 3/8)	EM 04	SK 40	78	48	147	68.25	M16	15	23.5	4.1	F3304781	★
			SK 50 ¹⁾	78	48	159	101.60	M24	15	23.5	4.1	F3304783	★
KSN 5	M22 - M48 (7/8 - 1 7/8)	EM 05	SK 40	96	60	160	68.25	M16	16.5	25	5.7	F3305781	★
			SK 50	96	60	160	101.60	M24	16.5	25	5.7	F3305783	★

¹⁾ Adaption by DIN 1835 B

Further designs upon request

Accessories



Quick-change adapters EM series ▶▶ 583 - 601

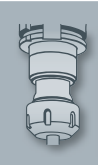

KSN

SK Shank

ANSI B5.18, NMTP

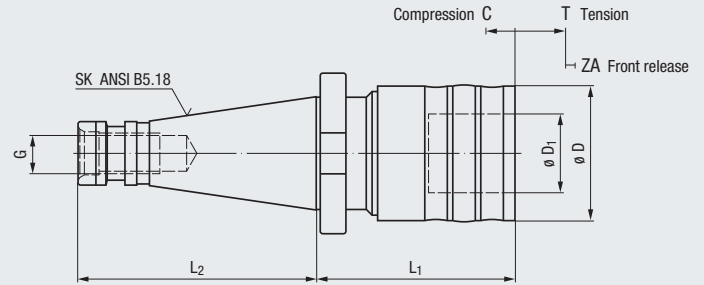
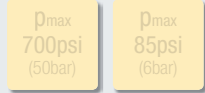
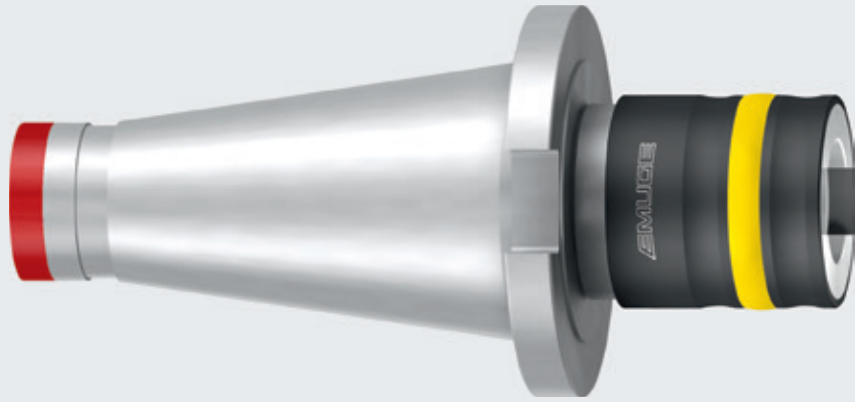

For use on CNC machining centers,
other machine tools and pillar drilling machines

Type	Image	Image	Shank Size	inch								EDP Number	★
				ø D	ø D ₁	L ₁	L ₂	G	C	T	ZA		
KSN 1	M3 - M14 (No.0 - 9/16)	EM 01	SK 40 ¹⁾	1.4173	0.7480	2.3858	3.6772	5/8 - 11	0.1969	0.3150	0.0827	F3301541.16	★
			SK 50 ¹⁾	1.4173	0.7480	2.1654	4.9921	1 - 8	0.1969	0.3150	0.0827	F3301543.16	★
KSN 3	M4.5 - M24 (1/4 - 7/8)	EM 03	SK 40 ¹⁾	2.0866	1.2205	3.3307	3.6772	5/8 - 11	0.3346	0.5906	0.1102	F3303541.16	★
			SK 50 ¹⁾	2.0866	1.2205	3.1102	4.9921	1 - 8	0.3346	0.5906	0.1102	F3303543.16	★
KSN 4	M14 - M36 (5/8 - 1 3/8)	EM 04	SK 40	3.0709	1.8898	5.6299	3.6772	5/8 - 11	0.5906	0.9252	0.1614	F3304541.16	★
			SK 50 ¹⁾	3.0709	1.8898	5.5118	4.9921	1 - 8	0.5906	0.9252	0.1614	F3304543.16	★
KSN 5	M22 - M48 (7/8 - 1 7/8)	EM 05	SK 40	3.7795	2.3622	6.1811	3.6772	5/8 - 11	0.6496	0.9843	0.2244	F3305541.16	★
			SK 50	3.7795	2.3622	5.6693	4.9921	1 - 8	0.6496	0.9843	0.2244	F3305543.16	★

¹⁾ Adaption by DIN 1835 B

Further designs upon request

SK 40 and SK 50 shanks are equipped with a ring groove for MAHO and Deckel

Accessories



Quick-change adapters EM series ▶▶ 583 - 601

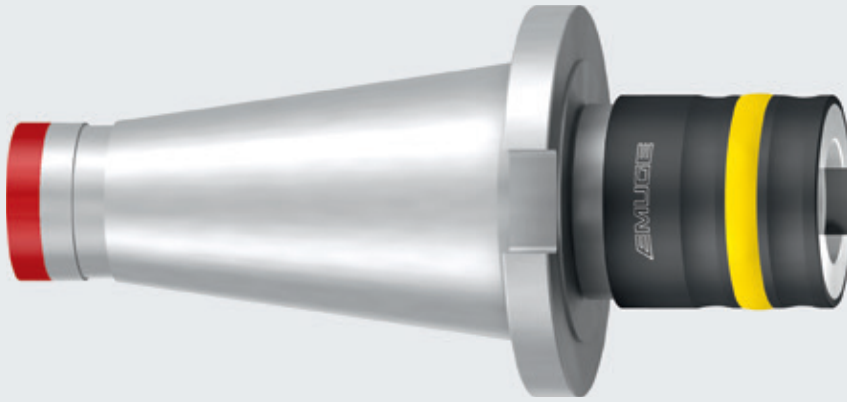

KSN
SK Shank
DIN 2080

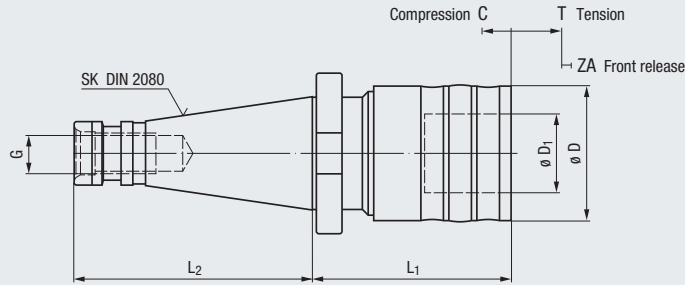
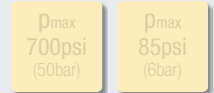

For use on CNC machining centers,
other machine tools and pillar drilling machines

Type	Image	Image	Shank Size	mm								EDP Number	★
				ø D	ø D ₁	L ₁	L ₂	G	C	T	ZA		
KSN 1	M3 - M14 (No.0 - 9/16)	EM 01	SK 30 ¹⁾	36	19	73	68.4	M12	5	8	2.1	F3301540	★
			SK 40 ¹⁾	36	19	60.6	93.4	M16	5	8	2.1	F3301541	★
			SK 50 ¹⁾	36	19	55	126.8	M24	5	8	2.1	F3301543	★
KSN 3	M4.5 - M24 (1/4 - 7/8)	EM 03	SK 30	53	31	97	68.4	M12	8.5	15	2.8	F3303540	★
			SK 40 ¹⁾	53	31	84.6	93.4	M16	8.5	15	2.8	F3303541	★
			SK 50 ¹⁾	53	31	79	126.8	M24	8.5	15	2.8	F3303543	★
KSN 4	M14 - M36 (5/8 - 1 3/8)	EM 04	SK 40	78	48	143	93.4	M16	15	23.5	4.1	F3304541	★
			SK 50 ¹⁾	78	48	140	126.8	M24	15	23.5	4.1	F3304543	★
KSN 5	M22 - M48 (7/8 - 1 7/8)	EM 05	SK 40	96	60	157	93.4	M16	16.5	25	5.7	F3305541	★
			SK 50	96	60	144	126.8	M24	16.5	25	5.7	F3305543	★

¹⁾Adaption by DIN 1835 B

Further designs upon request

SK 40 and SK 50 shanks are equipped with a ring groove for MAHO and Deckel

Accessories



Quick-change adapters EM series » 583 - 601



- Product Finder
- Soft-synchro
- Speed-synchro
- KSN**
- MQL
- SFM
- HF
- EM
- Accessories
- Tech. Info

KSN

CAT Shank

ASME B5.50, UNC drawbolt thread

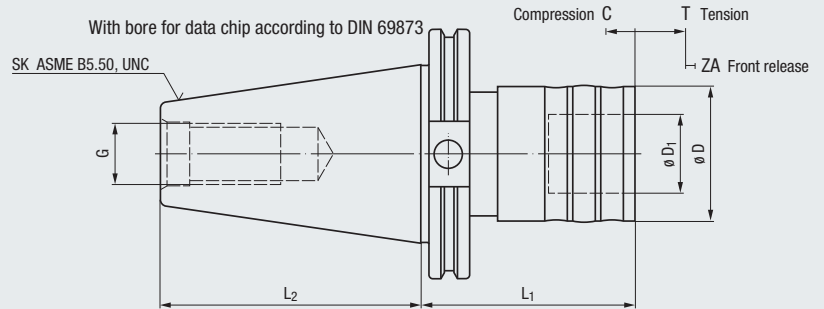
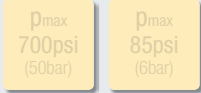

For use on CNC machining centers, other machine tools and pillar drilling machines

Type	Shank Size	inch										EDP Number	
		ø D	ø D ₁	L ₁	L ₂	G	C	T	ZA				
KSN 1	M3 - M14 (No.0 - 9/16)	EM 01	CAT 40 ¹⁾	1.4173	0.7480	2.9134	2.6870	5/8 - 11	0.1969	0.3150	0.0827	F3301781.16	●
			CAT 50 ¹⁾	1.4173	0.7480	2.9134	4.0000	1 - 8	0.1969	0.3150	0.0827	F3301783.16	●
KSN 3	M4.5 - M24 (1/4 - 7/8)	EM 03	CAT 40 ¹⁾	2.0866	1.2205	3.8583	2.6870	5/8 - 11	0.3346	0.5906	0.1102	F3303781.16	●
			CAT 50 ¹⁾	2.0866	1.2205	3.8583	4.0000	1 - 8	0.3346	0.5906	0.1102	F3303783.16	●
KSN 4	M14 - M36 (5/8 - 1 3/8)	EM 04	CAT 40	3.0709	1.8898	5.7874	2.6870	5/8 - 11	0.5906	0.9252	0.1614	F3304781.16	●
			CAT 50 ¹⁾	3.0709	1.8898	6.2598	4.0000	1 - 8	0.5906	0.9252	0.1614	F3304783.16	●
KSN 5	M22 - M48 (7/8 - 1 7/8)	EM 05	CAT 40	3.7795	2.3622	6.2992	2.6870	5/8 - 11	0.6496	0.9843	0.2244	F3305781.16	●
			CAT 50	3.7795	2.3622	6.2992	4.0000	1 - 8	0.6496	0.9843	0.2244	F3305783.16	●

¹⁾ Adaption by DIN 1835 B

Further designs upon request

Accessories



Quick-change adapters EM series ▶▶ 583 - 601

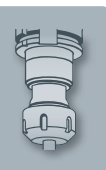

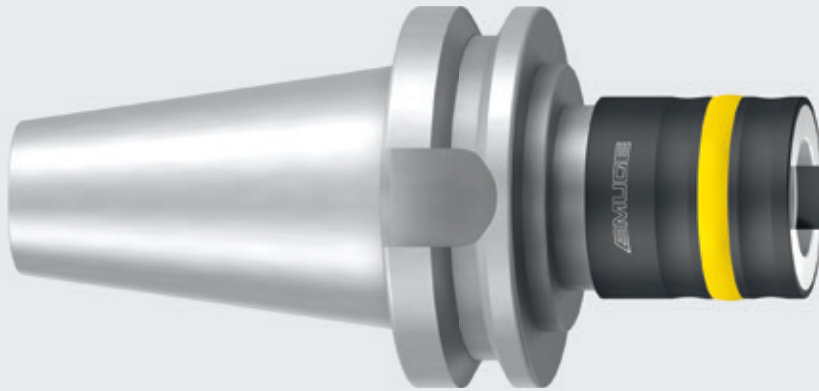

KSN

BT Shank

JIS B 6339 (MAS 403 BT)

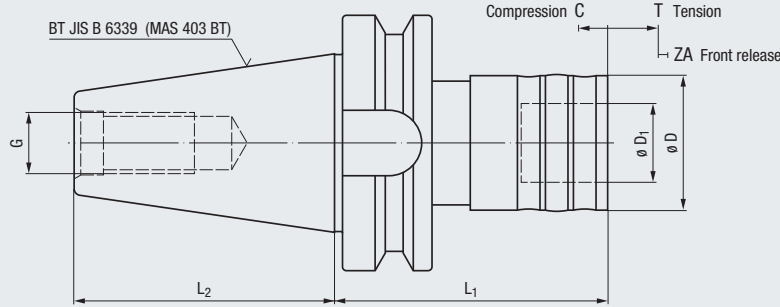
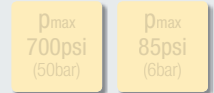

For use on CNC machining centers, other machine tools and pillar drilling machines

Type	Image	Image	Shank Size	inch								EDP Number	
				ø D	ø D ₁	L ₁	L ₂	G	C	T	ZA		
KSN 1	M3 - M14 (No.0 - 9/16)	EM 01	BT 40 ¹⁾	1.4173	0.7480	2.9134	2.5748	M16	0.1969	0.3150	0.0827	F3301891	★
			BT 50 ¹⁾	1.4173	0.7480	3.2677	4.0079	M24	0.1969	0.3150	0.0827	F3301893	★
KSN 3	M4.5 - M24 (1/4 - 7/8)	EM 03	BT 40 ¹⁾	2.0866	1.2205	3.8583	2.5748	M16	0.3346	0.5906	0.1102	F3303891	★
			BT 50 ¹⁾	2.0866	1.2205	4.2126	4.0079	M24	0.3346	0.5906	0.1102	F3303893	★
KSN 4	M14 - M36 (5/8 - 1 3/8)	EM 04	BT 40	3.0709	1.8898	6.4567	2.5748	M16	0.5906	0.9252	0.1614	F3304891	★
			BT 50 ¹⁾	3.0709	1.8898	6.6142	4.0079	M24	0.5906	0.9252	0.1614	F3304893	★
KSN 5	M22 - M48 (7/8 - 1 7/8)	EM 05	BT 40	3.7795	2.3622	6.5945	2.5748	M16	0.6496	0.9843	0.2244	F3305891	★
			BT 50	3.7795	2.3622	6.5157	4.0079	M24	0.6496	0.9843	0.2244	F3305893	★

¹⁾ Adaption by DIN 1835 B

Further designs upon request

Accessories



- Product Finder
- Soft-synchro
- Speed-synchro
- KSN**
- MQL
- SFM
- HF
- EM
- Accessories
- Tech. Info

KSN

Morse Taper Shank

DIN 228 B (ASME B5.10)

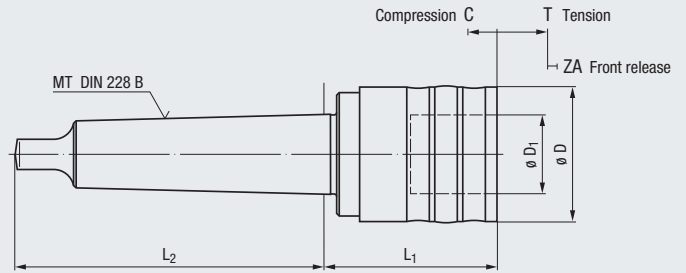
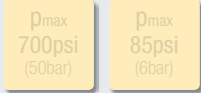
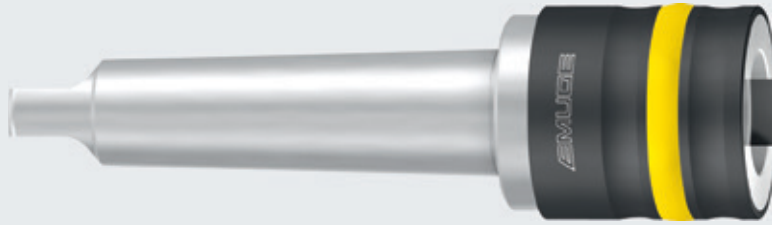

For use on CNC machining centers, other machine tools and pillar drilling machines

Type	Shank Size	inch									EDP Number	
		ø D	ø D ₁	L ₁	L ₂	C	T	ZA				
KSN 0	M1 - M10 (No.0 - 1/4)	EM 00	MT 1	1.0236	0.5118	1.7126	2.4409	0.1969	0.2953	0.0669	F3300101	★
			MT 2	1.0236	0.5118	1.7717	2.9528	0.1969	0.2953	0.0669	F3300102	●
KSN 1	M3 - M14 (No.0 - 9/16)	EM 01	MT 2	1.4173	0.7480	1.8504	2.9528	0.1969	0.3150	0.0827	F3301102	●
			MT 3	1.4173	0.7480	1.8504	3.7008	0.1969	0.3150	0.0827	F3301103	●
KSN 3	M4.5 - M24 (1/4 - 7/8)	EM 03	MT 3	2.0866	1.2205	2.7953	3.7008	0.3346	0.5906	0.1102	F3303103	●
			MT 4	2.0866	1.2205	2.8346	4.6260	0.3346	0.5906	0.1102	F3303104	●
			MT 5	2.0866	1.2205	2.8543	5.8858	0.3346	0.5906	0.1102	F3303105	●
KSN 4	M14 - M36 (5/8 - 1 3/8)	EM 04	MT 4	3.0709	1.8898	4.1339	4.6260	0.5906	0.9252	0.1614	F3304104	●
			MT 5	3.0709	1.8898	4.1535	5.8858	0.5906	0.9252	0.1614	F3304105	●
KSN 5	M22 - M48 (7/8 - 1 7/8)	EM 05	MT 5	3.7795	2.3622	4.5866	5.8858	0.6496	0.9843	0.2244	F3305105	●
			MT 6	3.7795	2.3622	4.6654	8.2677	0.6496	0.9843	0.2244	F3305106	★

Morse taper shank with clamping thread acc. DIN 228 A upon request

Further designs upon request

Accessories



Quick-change adapters EM series ▶▶ 583 - 601

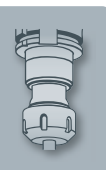

KSN

Trapezoidal Shank

DIN 6327

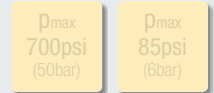
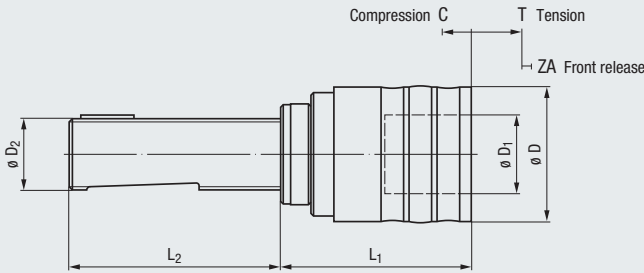
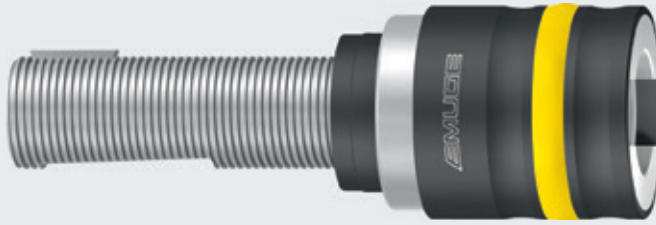

For use on CNC machining centers, other machine tools and pillar drilling machines

Type			Shank Size $\varnothing D_2$	$\varnothing D$	$\varnothing D_1$	L_1	L_2	C	T	ZA	EDP Number	
KSN 0	M1 - M10 (No.0 - 1/4)	EM 00	Tr 16 x 1.5	26	13	50	73	5	7.5	1.7	F3300213	★
			Tr 20 x 2	26	13	50	76	5	7.5	1.7	F3300214	★
KSN 1	M3 - M14 (No.0 - 9/16)	EM 01	Tr 16 x 1.5	36	19	52	73	5	8	2.1	F3301213	★
			Tr 20 x 2	36	19	52	76	5	8	2.1	F3301214	★
			Tr 28 x 2	36	19	52	83	5	8	2.1	F3301216	★
			Tr 36 x 2	36	19	54	104	5	8	2.1	F3301218	★
KSN 3	M4.5 - M24 (1/4 - 7/8)	EM 03	Tr 20 x 2	53	31	76	76	8.5	15	2.8	F3303214	★
			Tr 28 x 2	53	31	76	83	8.5	15	2.8	F3303216	★
			Tr 36 x 2	53	31	78	104	8.5	15	2.8	F3303218	★
KSN 4	M14 - M36 (5/8 - 1 3/8)	EM 04	Tr 28 x 2	78	48	109	83	15	23.5	4.1	F3304216	★
			Tr 36 x 2	78	48	111	104	15	23.5	4.1	F3304218	★
			Tr 48 x 2	78	48	115	126	15	23.5	4.1	F3304219	★
KSN 5	M22 - M48 (7/8 - 1 7/8)	EM 05	Tr 36 x 2	96	60	122	104	16.5	25	5.7	F3305218	★
			Tr 48 x 2	96	60	126	126	16.5	25	5.7	F3305219	★

Further designs upon request

Accessories



Quick-change adapters EM series ▶▶ 583 - 601



- Product Finder
- Soft-synchro
- Speed-synchro
- KSN**
- MQL
- SFM
- HF
- EM
- Accessories
- Tech. Info

KSN

ACME Shank

ASME B5.11

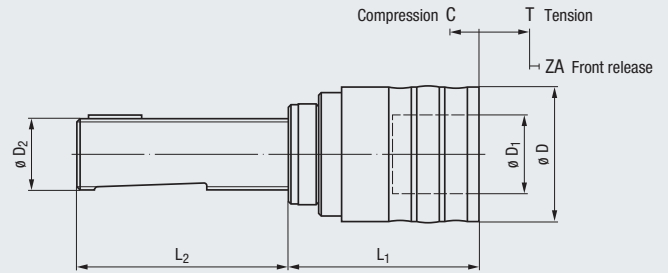
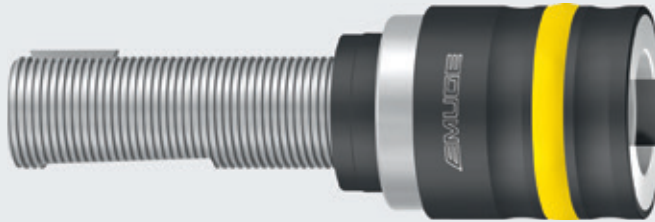

For use on CNC machining centers, other machine tools and pillar drilling machines

Type	Shank Size ϕD_2 ACME	inch									EDP Number	
		ϕD	ϕD_1	L_1	L_2	C	T	ZA				
KSN 1	M3 - M14 (No.0 - 9/16)	EM 01	5/8 x 16	1.4173	0.7480	1.9882	2.5787	0.1969	0.3150	0.0827	F3301M33	★
			3/4 x 12	1.4173	0.7480	1.9882	2.5787	0.1969	0.3150	0.0827	F3301M34	★
			1 1/16 x 12	1.4173	0.7480	1.9882	3.2087	0.1969	0.3150	0.0827	F3301M37	★
KSN 3	M4.5 - M24 (1/4 - 7/8)	EM 03	1 1/16 x 12	2.0866	1.2205	2.9331	3.2087	0.3346	0.5906	0.1102	F3303M37	★
			1 3/8 x 12	2.0866	1.2205	2.9331	4.2126	0.3346	0.5906	0.1102	F3303M39	★
KSN 4	M14 - M36 (5/8 - 1 3/8)	EM 04	1 3/8 x 12	3.0709	1.8898	4.2323	4.2126	0.5906	0.9252	0.1614	F3304M39	★
			1 7/8 x 12	3.0709	1.8898	4.2323	5.1772	0.5906	0.9252	0.1614	F3304M41	★

Further designs upon request

Accessories



Quick-change adapters EM series ▶▶ 583 - 601

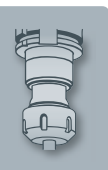

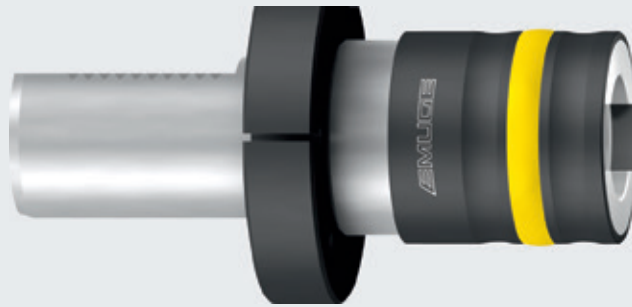

KSN

VDI Shank

DIN ISO 10889 (VDI 3425)

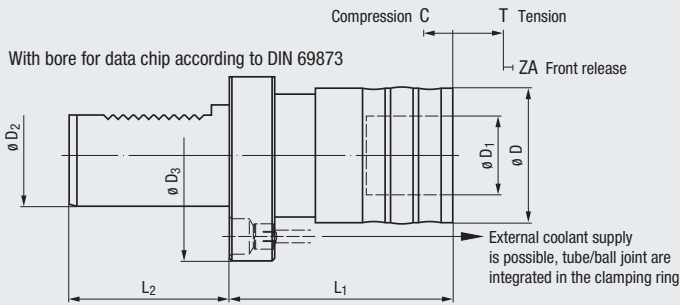

For use on CNC machining centers, other machine tools and pillar drilling machines

Type	Shank Size	EM	mm									EDP Number	★
			ø D ₂	ø D ₃	ø D	ø D ₁	L ₁	L ₂	C	T	ZA		
KSN 1	M3 - M14 (No.0 - 9/16)	EM 01	20	50	36	19	57	40	5	8	2.1	F3301430	★
			30	68	36	19	57	55	5	8	2.1	F3301431	★
			40	83	36	19	57	63	5	8	2.1	F3301432	★
			50	98	36	19	57	78	5	8	2.1	F3301433	★
KSN 3	M4.5 - M24 (1/4 - 7/8)	EM 03	30	68	53	31	88	55	8.5	15	2.8	F3303431	★
			40	83	53	31	88	63	8.5	15	2.8	F3303432	★
			50	98	53	31	88	78	8.5	15	2.8	F3303433	★
KSN 4	M14 - M36 (5/8 - 1 3/8)	EM 04	40	83	78	48	123	63	15	23.5	4.1	F3304432	★
			50	98	78	48	123	78	15	23.5	4.1	F3304433	★
			60	123	78	48	123	94	15	23.5	4.1	F3304434	★
KSN 5	M22 - M48 (7/8 - 1 7/8)	EM 05	50	98	96	60	140	78	16.5	25	5.7	F3305433	★
			60	123	96	60	140	94	16.5	25	5.7	F3305434	★

Further designs upon request

Accessories



Quick-change adapters EM series ▶▶ 583 - 601



- Product Finder
- Soft-synchro
- Speed-synchro
- KSN**
- MQL
- SFM
- HF
- EM
- Accessories
- Tech. Info

KSN

ABS® Shank

ABS®-clutch (System KOMET)

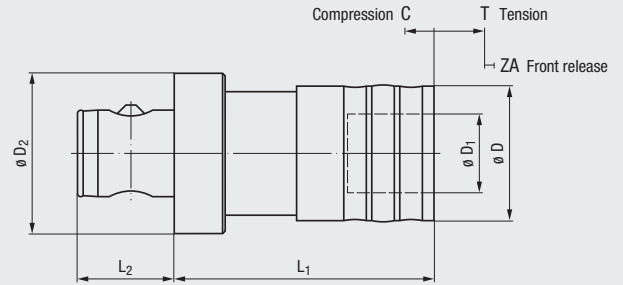
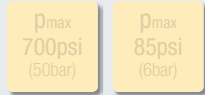

For use on CNC machining centers, other machine tools and pillar drilling machines

Type	Image	Image	Shank Size $\varnothing D_2$	mm							EDP Number	★
				$\varnothing D$	$\varnothing D_1$	L_1	L_2	C	T	ZA		
KSN 1	M3 - M14 (No.0 - 9/16)	EM 01	ABS 32	36	19	72	23	5	8	2.1	F3301L01	★
			ABS 40	36	19	72	26	5	8	2.1	F3301L02	★
			ABS 50	36	19	72	31	5	8	2.1	F3301L03	★
			ABS 63	36	19	72	38	5	8	2.1	F3301L04	★
KSN 3	M4.5 - M24 (1/4 - 7/8)	EM 03	ABS 50	53	31	102	31	8.5	15	2.8	F3303L03	★
			ABS 63	53	31	102	38	8.5	15	2.8	F3303L04	★
KSN 4	M14 - M36 (5/8 - 1 3/8)	EM 04	ABS 63	78	48	155	38	15	23.5	4.1	F3304L04	★

Further designs upon request

Accessories



Quick-change adapters EM series ▶▶ 583 - 601

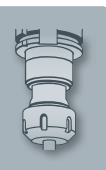

KSN/HD
HSK-A Shank
 DIN 69893 A

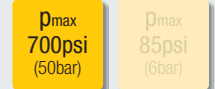
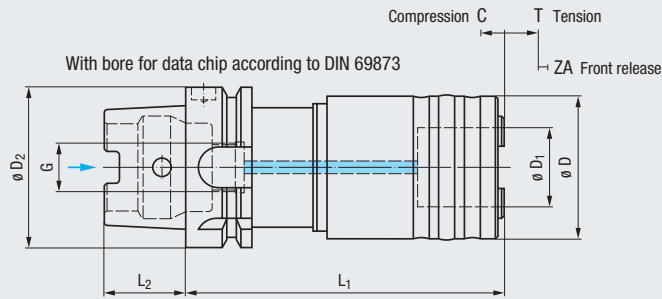
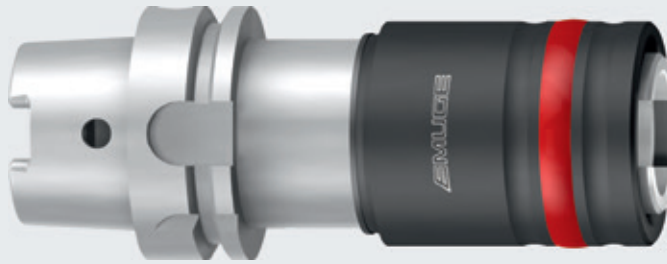

For use on CNC machining centers and other machine tools

Type	Thread	Adapter	Shank Size ø D ₂	mm								EDP Number	
				ø D	ø D ₁	L ₁	L ₂	G	C	T	ZA		
KSN 1/HD	M3 - M14 (No.0 - 9/16)	EM 01	HSK-A50	40	19	91	25	M16 x 1	5	7.5	2.5	F3101C03.1.30	★
			HSK-A63	40	19	93	32	M18 x 1	5	7.5	2.5	F3101C04.1.30	★
			HSK-A80	40	19	97	40	M20 x 1.5	5	7.5	2.5	F3101C05.1.30	★
			HSK-A100	40	19	98	50	M24 x 1.5	5	7.5	2.5	F3101C06.1.30	★
KSN 3/HD	M4.5 - M24 (1/4 - 7/8)	EM 03	HSK-A50	56	31	140	25	M16 x 1	7	10	3	F3103C03.1.30	★
			HSK-A63	56	31	130	32	M18 x 1	7	10	3	F3103C04.1.30	★
			HSK-A80	56	31	133	40	M20 x 1.5	7	10	3	F3103C05.1.30	★
			HSK-A100	56	31	135	50	M24 x 1.5	7	10	3	F3103C06.1.30	★

Further designs upon request

Accessories



Quick-change adapters EM series ▶▶ 583 - 601



Coolant tubes and wrenches ▶▶ 606 - 607



KSN/HD HSK-C Shank DIN 69893 C

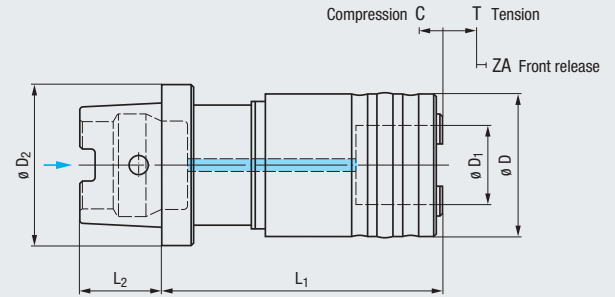
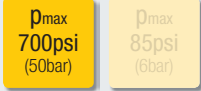

For use on CNC machining centers and other machine tools

Type			Shank Size ϕD_2	ϕD	ϕD_1	L_1	L_2	C	T	ZA	EDP Number	
KSN 1/HD	M3 - M14 (No.0 - 9/16)	EM 01	HSK-C40	40	19	75	20	5	7.5	2.5	F3101K02.1.30	★
			HSK-C50	40	19	78	25	5	7.5	2.5	F3101K03.1.30	★
			HSK-C63	40	19	78	32	5	7.5	2.5	F3101K04.1.30	★
			HSK-C80	40	19	81	40	5	7.5	2.5	F3101K05.1.30	
			HSK-C100	40	19	81	50	5	7.5	2.5	F3101K06.1.30	
KSN 3/HD	M4.5 - M24 (1/4 - 7/8)	EM 03	HSK-C50	56	31	118	25	7	10	3	F3103K03.1.30	★
			HSK-C63	56	31	110	32	7	10	3	F3103K04.1.30	★
			HSK-C80	56	31	113	40	7	10	3	F3103K05.1.30	
			HSK-C100	56	31	115	50	7	10	3	F3103K06.1.30	

Further designs upon request

Accessories



Quick-change adapters EM series ▶▶ 583 - 601





KSN/HD
PSC Shank
ISO 26623-1

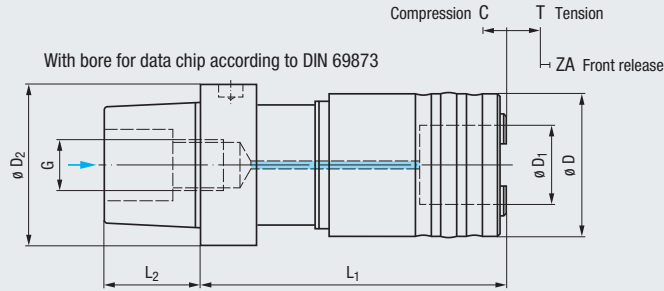

For use on CNC machining centers and other machine tools

Type	Image 1	Image 2	Shank Size ø D ₂	mm								EDP Number	★
				ø D	ø D ₁	L ₁	L ₂	G	C	T	ZA		
KSN 1/HD	M3 - M14 (No.0 - 9/16)	EM 01	PSC 63	40	19	86.5	38	M20 x 2	5	7.5	2.5	F3101T06.1	★
KSN 3/HD	M4.5 - M24 (1/4 - 7/8)	EM 03	PSC 63	56	31	120	38	M20 x 2	7	10	3	F3103T06.1	★

Further designs upon request

Accessories



Quick-change adapters EM series ▶▶ 583 - 601



KSN/HD

Cylindrical Shank

DIN 1835 B+E

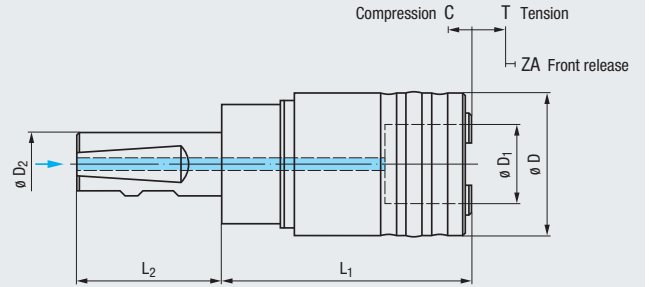
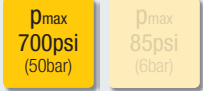

For use on CNC machining centers and other machine tools

Type			Shank Size $\varnothing D_2$	$\varnothing D$	$\varnothing D_1$	L_1	L_2	C	T	ZA	EDP Number	
KSN 1/HD	M3 - M14 (No.0 - 9/16)	EM 01	25	40	19	62	57	5	7.5	2.5	F3101G26.1	★
KSN 3/HD	M4.5 - M24 (1/4 - 7/8)	EM 03	25	56	31	98	57	7	10	3	F3103G26.1	★
KSN 4/HD	M14 - M36 (5/8 - 1 3/8)	EM 04	32	80	48	147	61	15	20	5	F3104G27.1	★

Further designs upon request

Accessories



Quick-change adapters EM series ▶▶ 583 - 601



Adapter shanks ▶▶ 604

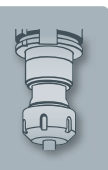



KSN/HD
Weldon Shank
ASME B94.19

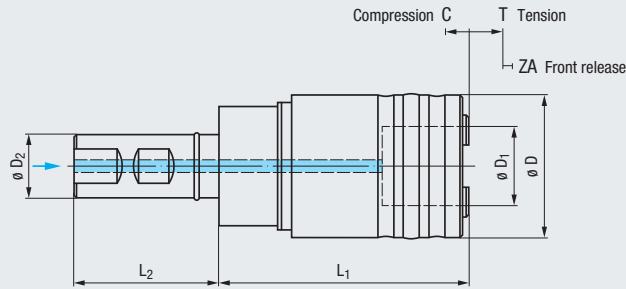
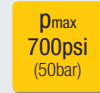

For use on CNC machining centers and other machine tools

Type	Shank Size ø D ₂	ø D	ø D ₁	inch				C	T	ZA	EDP Number	
				L ₁	L ₂							
KSN 1/HD	M3 - M14 (No.0 - 9/16)	EM 01	1	1.5748	0.7480	2.4409	2.2835	0.1969	0.2953	0.0984	F3101H36.1	●
	1 1/4		1.5748	0.7480	2.4409	2.2835	0.1969	0.2953	0.0984	F3101H38.1	●	
KSN 3/HD	M4.5 - M24 (1/4 - 7/8)	EM 03	1 1/4	2.2047	1.2205	3.8583	2.2835	0.2756	0.3937	0.1181	F3103H38.1	●
	1 1/2		2.2047	1.2205	3.8583	2.6890	0.2756	0.3937	0.1181	F3103H40.1	●	
KSN 4/HD	M14 - M36 (5/8 - 1 3/8)	EM 04	1 1/2	3.1496	1.8898	5.7874	2.6890	0.5906	0.7874	0.1969	F3104H40.1	●

Further designs upon request

Accessories



Quick-change adapters EM series ▶▶ 583 - 601



Adapter shanks ▶▶ 604



KSN/HD

SK Shank

DIN 69871 AD

DIN 69871 B

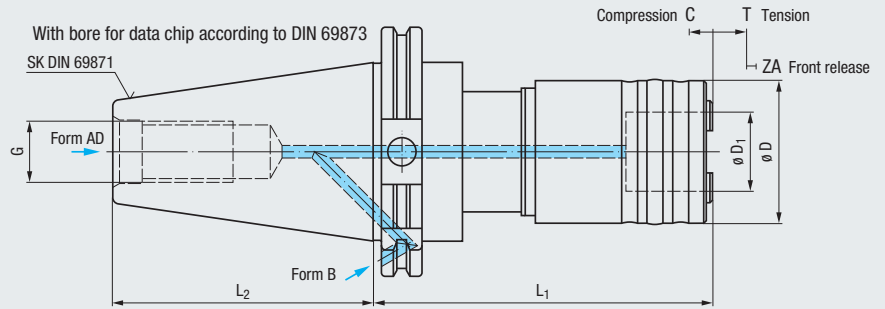
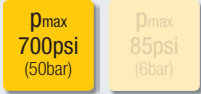
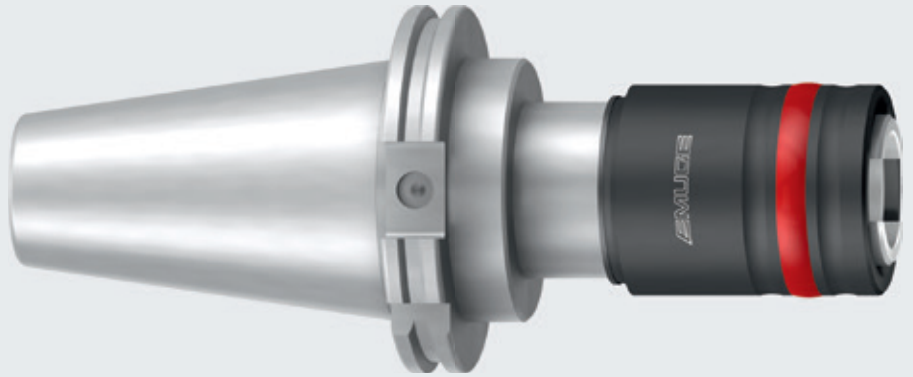

For use on CNC machining centers and other machine tools

Type	Image	Image	Shank Size 1)	mm								EDP Number	★
				ø D	ø D ₁	L ₁	L ₂	G	C	T	ZA		
KSN 1/HD	M3 - M14 (No.0 - 9/16)	EM 01	SK 40 AD	40	19	98	68.4	M16	5	7.5	2.5	F3101651.1	★
			SK 40 B	40	19	98	68.4	M16	5	7.5	2.5	F3101651.2	★
			SK 50 AD	40	19	98	101.75	M24	5	7.5	2.5	F3101653.1	★
			SK 50 B	40	19	98	101.75	M24	5	7.5	2.5	F3101653.2	★
KSN 3/HD	M4.5 - M24 (1/4 - 7/8)	EM 03	SK 40 AD	56	31	134	68.4	M16	7	10	3	F3103651.1	★
			SK 40 B	56	31	134	68.4	M16	7	10	3	F3103651.2	★
			SK 50 AD	56	31	134	101.75	M24	7	10	3	F3103653.1	★
			SK 50 B	56	31	134	101.75	M24	7	10	3	F3103653.2	★

1) Adaptation by DIN 1835 B

Further designs upon request

Accessories



Quick-change adapters EM series ▶▶ 583 - 601

KSN/HD
Trapezoidal Shank
DIN 6327

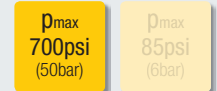
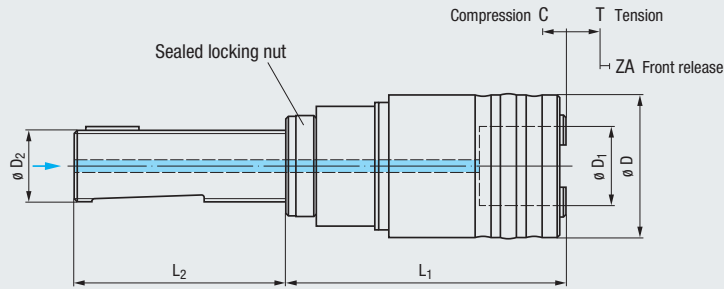
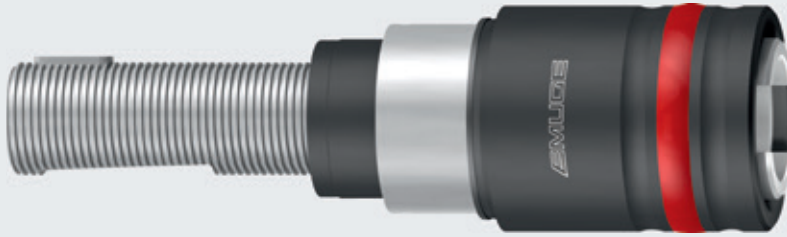

For use on CNC machining centers and other machine tools

Type	Shank Size $\varnothing D_2$	mm									EDP Number	
		$\varnothing D$	$\varnothing D_1$	L_1	L_2	C	T	ZA				
KSN 1/HD	M3 - M14 (No.0 - 9/16)	EM 01	Tr 20 x 2	40	19	79	71	5	7.5	2.5	F3101214.1	★
			Tr 28 x 2	40	19	80	77	5	7.5	2.5	F3101216.1	★
KSN 3/HD	M4.5 - M24 (1/4 - 7/8)	EM 03	Tr 28 x 2	56	31	116	77	7	10	3	F3103216.1	★
			Tr 36 x 2	56	31	118	98	7	10	3	F3103218.1	★

Further designs upon request

Accessories



Quick-change adapters EM series ▶▶ 583 - 601



KSN/HD ACME Shank ASME B5.11

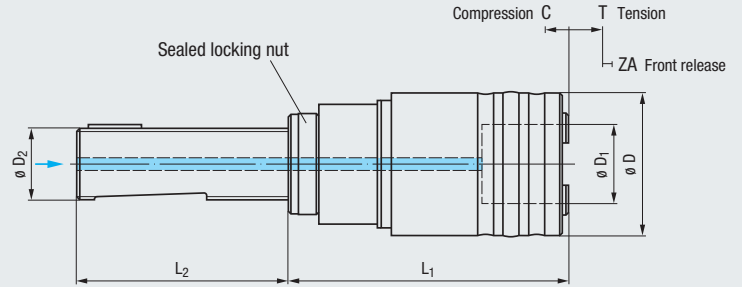
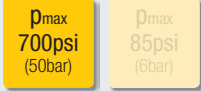
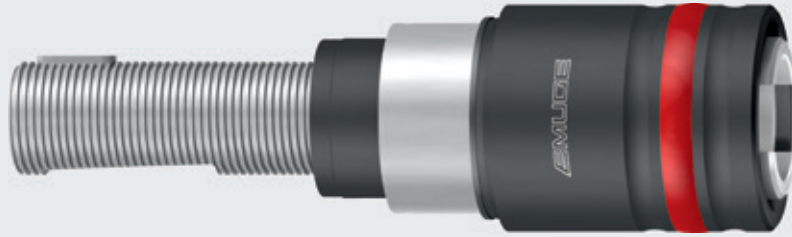

For use on CNC machining centers and other machine tools

Type	Shank Size ϕD_2 ACME	inch									EDP Number	
		ϕD	ϕD_1	L_1	L_2	C	T	ZA				
KSN 1/HD	M3 - M14 (No.0 - 9/16)	EM 01	3/4 x 12	1.5748	0.7480	3.1890	2.2441	0.1969	0.2953	0.0984	F3101M34.1	★
			1 1/16 x 12	1.5748	0.7480	3.1890	2.8740	0.1969	0.2953	0.0984	F3101M37.1	★
KSN 3/HD	M4.5 - M24 (1/4 - 7/8)	EM 03	1 1/16 x 12	2.2047	1.2205	4.6063	2.8740	0.2756	0.3937	0.1181	F3103M37.1	★
			1 3/8 x 12	2.2047	1.2205	4.6063	3.8780	0.2756	0.3937	0.1181	F3103M39.1	★

Further designs upon request

Accessories



Quick-change adapters EM series ▶▶ 583 - 601

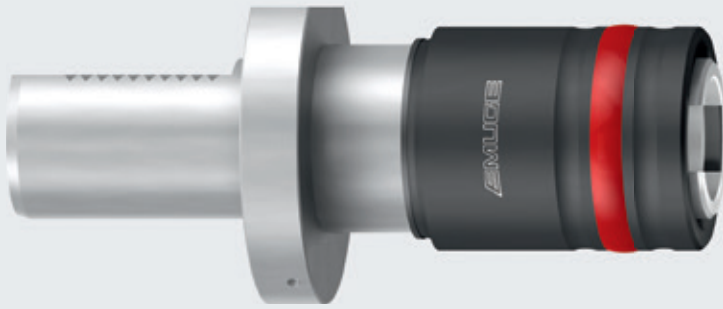

KSN/HD
VDI Shank
 DIN ISO 10889 (VDI 3425)

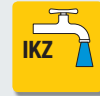

p_{max}
700psi
 (50bar)

p_{max}
85psi
 (6bar)

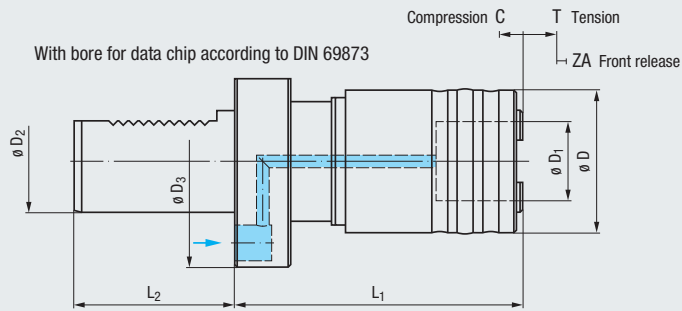

For use on CNC machining centers
 and other machine tools

Type	Image	Image	mm										EDP Number	★
			Shank Size ø D ₂	ø D ₃	ø D	ø D ₁	L ₁	L ₂	C	T	ZA			
KSN 1/HD	M3 - M14 (No.0 - 9/16)	EM 01	30	68	40	19	77	55	5	7.5	2.5	F3101431.1	★	
			40	83	40	19	77	63	5	7.5	2.5	F3101432.1	★	
			50	98	40	19	77	78	5	7.5	2.5	F3101433.1		
KSN 3/HD	M4.5 - M24 (1/4 - 7/8)	EM 03	30	68	56	31	113	55	7	10	3	F3103431.1	★	
			40	83	56	31	113	63	7	10	3	F3103432.1	★	
			50	98	56	31	113	78	7	10	3	F3103433.1	★	

Further designs upon request

Accessories



Quick-change adapters EM series ▶▶ 583 - 601



- Product Finder
- Soft-synchro
- Speed-synchro
- KSN**
- MQL
- SFM
- HF
- EM
- Accessories
- Tech. Info

KSN/HD

ABS® Shank

ABS®-clutch (System KOMET)

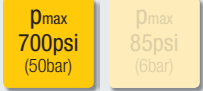

For use on CNC machining centers and other machine tools

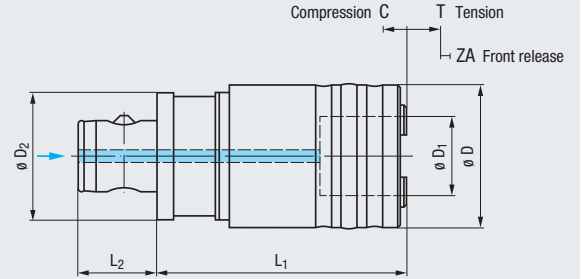

Type	Image	Image	Shank Size ø D ₂	mm							EDP Number	★
				ø D	ø D ₁	L ₁	L ₂	C	T	ZA		
KSN 1/HD	M3 - M14 (No.0 - 9/16)	EM 01	ABS 32	40	19	69	23	5	7.5	2.5	F3101L01.1	★
KSN 3/HD	M4.5 - M24 (1/4 - 7/8)	EM 03	ABS 50	56	31	98	31	7	10	3	F3103L03.1	★

Further designs upon request

Accessories



Quick-change adapters EM series ▶▶ 583 - 601

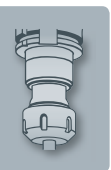

KSN/HD/ER

HSK-A Shank

DIN 69893 A

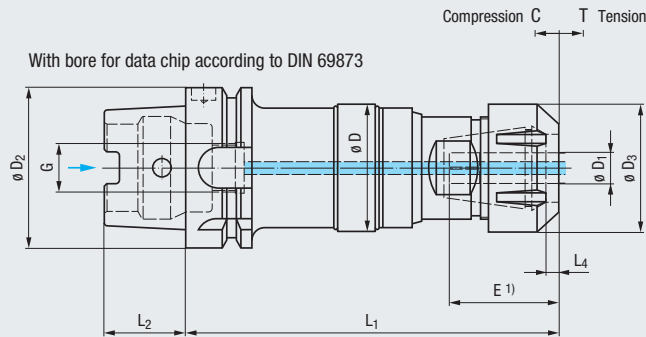
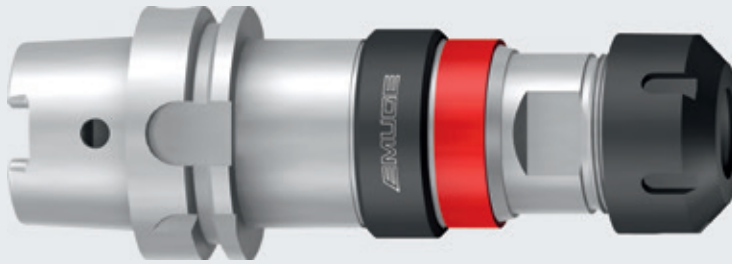

IKZ

MQL

p_{max}
700psi
(50bar)

p_{max}
85psi
(6bar)

C T

F

For use on CNC machining centers
and other machine tools

Type	Image	ϕD_1	Image	Image	Shank Size ϕD_2	mm							EDP Number		
						ϕD	ϕD_3	L ₁	L ₂	L ₄	G	C			T
KSN 1/HD/ER	M4 - M12 (No.8 - 1/2)	4.5 - 10 mm 0.168 - 0.381	ER 20 (GB)	Hi-Q/ERMC 20	HSK-A50	38	28	114	25	5	M16 x 1	5	7.5	F3231C03.1	★
					HSK-A63	38	28	116	32	5	M18 x 1	5	7.5	F3231C04.1	★
					HSK-A80	38	28	120	40	5	M20 x 1.5	5	7.5	F3231C05.1	★
					HSK-A100	38	28	121	50	5	M24 x 1.5	5	7.5	F3231C06.1	★
KSN 3/HD/ER	M4 - M20 (1/4 - 3/4)	4.5 - 16 mm 0.255 - 0.590	ER 32 (GB)	Hi-Q/ERC 32	HSK-A50	52	50	157	25	5	M16 x 1	7	10	F3233C03.1	★
					HSK-A63	52	50	147	32	5	M18 x 1	7	10	F3233C04.1	★
					HSK-A80	52	50	150	40	5	M20 x 1.5	7	10	F3233C05.1	★
					HSK-A100	52	50	152	50	5	M24 x 1.5	7	10	F3233C06.1	★

1) Clamping depths E, see page 624 - 625

Further designs upon request

Clamping nut for sealing disks is included in the delivery

Accessories

- Collets type ER (GB) ▶▶ 610 - 613
- Sealing disks type DS/ER ▶▶ 616
- Set of clamping wrenches ▶▶ 622
- Coolant tubes and wrenches ▶▶ 606 - 607

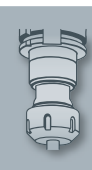

KSN/HD/ER

HSK-C Shank

DIN 69893 C

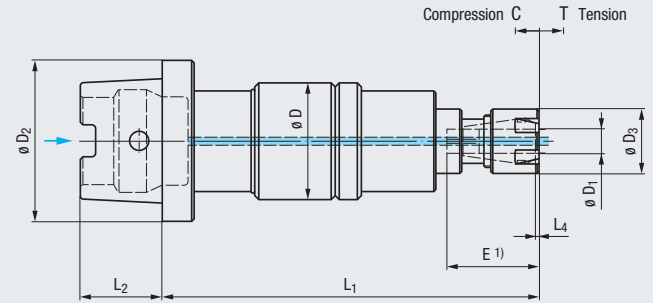
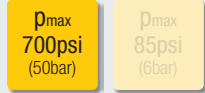

For use on CNC machining centers and other machine tools

Type	Collet	Ø D ₁	Clamping Nut	Shank Size Ø D ₂	mm										EDP Number	
					Ø D	Ø D ₃	L ₁ ER	L ₁ ER-GB	L ₂	L ₄	C	T				
KSN 0/HD/ER	M2 - M8 (No.0 - No.10)	2.5 - 6 mm 0.141 - 0.194	ER 11 (GB)	Hi-Q/ERM 11	HSK-C32	29	16	97.3	95.5	16	0.9	6	6	F3230K01.1	★	
					HSK-C40	29	16	97.3	95.5	20	0.9	6	6	F3230K02.1	★	

1) Clamping depths E, see page 624 - 625

Further designs upon request

Clamping nut without integrated seal is included in the delivery

Accessories



Collets type ER (GB)

▶▶ 610 - 613



Clamping nut with integrated seal, type Hi-Q/ERM 11

▶▶ 618



Set of clamping wrenches

▶▶ 622

KSN/HD/ER

Cylindrical Shank

DIN 1835 B+E

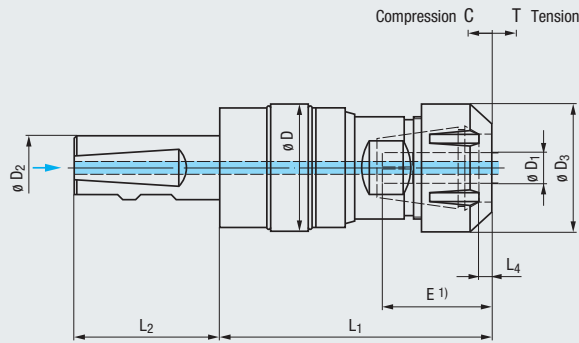

IKZ

MQL

p_{max}
700psi
(50bar)

p_{max}
85psi
(6bar)

C T

F

For use on CNC machining centers
and other machine tools

Type	Image	ϕD_1	Image	Image	Shank Size ϕD_2	mm						EDP Number		
						ϕD	ϕD_3	L_1	L_2	L_4	C			T
KSN 1/HD/ER	M4 - M12 (No.8 - 1/2)	4.5 - 10 mm 0.168 - 0.381	ER 20 (GB)	Hi-Q/ERMC 20	25	38	28	85	57	5	5	7.5	F3231G26.1	★
KSN 3/HD/ER	M4 - M20 (1/4 - 3/4)	4.5 - 16 mm 0.255 - 0.590	ER 32 (GB)	Hi-Q/ERC 32	25	52	50	115	57	5	7	10	F3233G26.1	★

1) Clamping depths E, see page 624 - 625

Further designs upon request

Clamping nut for sealing disks is included in the delivery

Accessories

- Collets type ER (GB)
▶▶ 610 - 613
- Sealing disks type DS/ER
▶▶ 616
- Set of clamping wrenches
▶▶ 622
- Adapter shanks
▶▶ 604

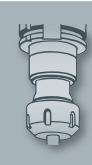

- Product Finder
- Soft-synchro
- Speed-synchro
- KSN**
- MQL
- SFM
- HF
- EM
- Accessories
- Tech. Info

KSN/HD/PGR

HSK-A Shank

DIN 69893 A

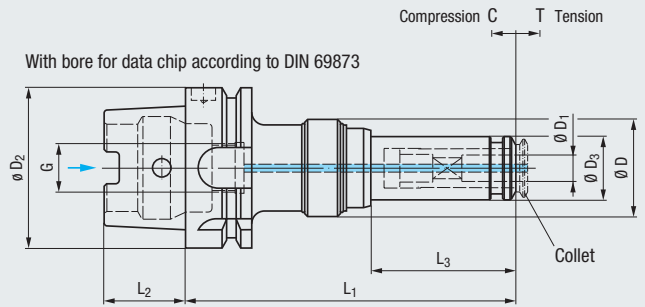
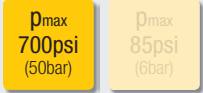
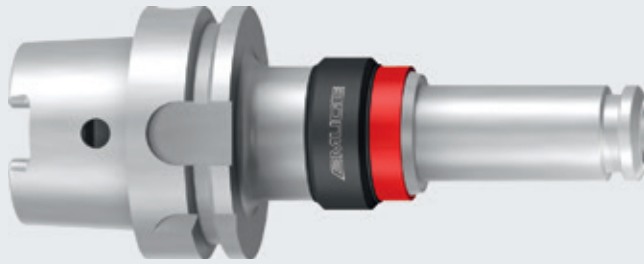

For use on CNC machining centers and other machine tools

Type		$\varnothing D_1$		Shank Size $\varnothing D_2$	mm								EDP Number	
					$\varnothing D$	$\varnothing D_3$	L_1	L_2	L_3	G	C	T		
KSN 1/HD/PGR	M4 - M12 (No.10 - 1/4)	4.5 - 10 mm 0.194 - 0.255	PGR 15 GB	HSK-A50	38	24	124	25	55	M16 x 1	5	7.5	F3241C03.1	★
				HSK-A63	38	24	126	32	55	M18 x 1	5	7.5	F3241C04.1	★
				HSK-A80	38	24	130	40	55	M20 x 1.5	5	7.5	F3241C05.1	
				HSK-A100	38	24	131	50	55	M24 x 1.5	5	7.5	F3241C06.1	
KSN 3/HD/PGR	M8 - M20 (1/4 - 3/4)	8 - 16 mm 0.255 - 0.590	PGR 25 GB	HSK-A50	52	40	170	25	66.5	M16 x 1	7	10	F3243C03.1	★
				HSK-A63	52	40	160	32	66.5	M18 x 1	7	10	F3243C04.1	★
				HSK-A80	52	40	163	40	66.5	M20 x 1.5	7	10	F3243C05.1	★
				HSK-A100	52	40	165	50	66.5	M24 x 1.5	7	10	F3243C06.1	★

Further designs upon request

Accessories



Collets type PGR-GB

» 630



Coolant tubes and wrenches

» 606 - 607

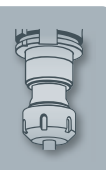

KSN/HD/PGR

Cylindrical Shank

DIN 1835 B+E

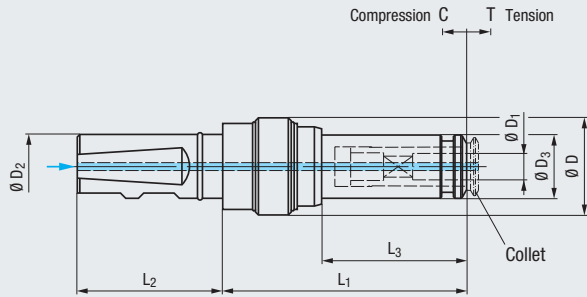

For use on CNC machining centers and other machine tools

Type	Image	ø D ₁	Image	Shank Size ø D ₂	mm							EDP Number	★
					ø D	ø D ₃	L ₁	L ₂	L ₃	C	T		
KSN 1/HD/PGR	M4 - M12 (No.10 - 1/4)	4.5 - 10 mm 0.194 - 0.255	PGR 15 GB	25	38	24	95	57	55	5	7.5	F3241G26.1	★
KSN 3/HD/PGR	M8 - M20 (1/4 - 3/4)	8 - 16 mm 0.255 - 0.590	PGR 25 GB	25	52	40	128	57	66.5	7	10	F3243G26.1	★

Further designs upon request

Accessories



Collets type PGR-GB ▶▶ 630



Adapter shanks ▶▶ 604



KSN/Synchro

HSK-A Shank

DIN 69893 A

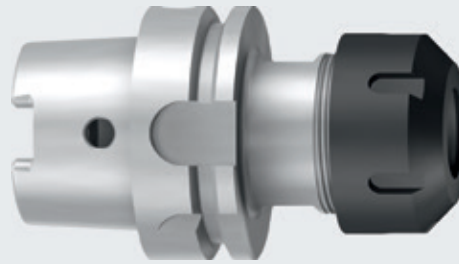

With bore for data chip according to DIN 69873

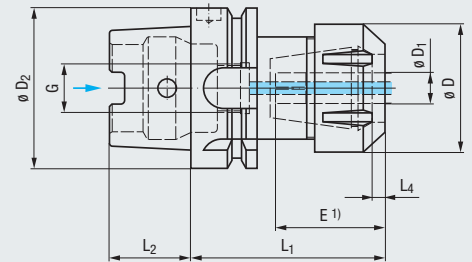

Type		$\varnothing D_1$			Shank Size $\varnothing D_2$	mm					EDP Number	
						$\varnothing D$	L_1	L_2	L_4	G		
KSN 1/ Synchro	M4 - M12 (No.8 - 1/2)	4.5 - 10 mm 0.168 - 0.381	ER 20 (GB)	Hi-Q/ERC 20	HSK-A50	34	68	25	5	M16 x 1	F3131C03.1.30	★
					HSK-A63	34	68	32	5	M18 x 1	F3131C04.1.30	★
					HSK-A100	34	74	50	5	M24 x 1.5	F3131C06.1.30	★
KSN 3/ Synchro	M4 - M20 (1/4 - 3/4)	4.5 - 16 mm 0.255 - 0.590	ER 32 (GB)	Hi-Q/ERC 32	HSK-A50	50	76	25	5	M16 x 1	F3133C03.1.30	★
					HSK-A63	50	77	32	5	M18 x 1	F3133C04.1.30	★
					HSK-A100	50	84	50	5	M24 x 1.5	F3133C06.1.30	★
KSN 4/ Synchro	M10 - M30 (1/4 - 1)	7 - 22 mm 0.255 - 0.800	ER 40 (GB)	Hi-Q/ERC 40	HSK-A63	63	80	32	5	M18 x 1	F3134C04.1.30	★
					HSK-A100	63	91	50	5	M24 x 1.5	F3134C06.1.30	★

1) Clamping depths E, see page 624 - 625

Further designs upon request

Clamping nut for sealing disks is included in the delivery

Accessories



Collets type ER (GB)

▶▶ 610 - 613



Sealing disks type DS/ER

▶▶ 616



Clamping wrench

▶▶ 622



Coolant tubes and wrenches

▶▶ 606 - 607

KSN/Synchro

Cylindrical Shank

DIN 1835 B+E

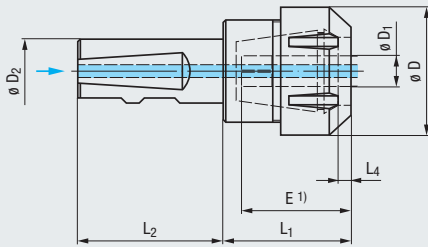
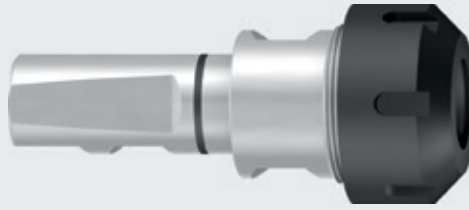

- Product Finder
- Soft-synchro
- Speed-synchro
- KSN**
- MQL
- SFM
- HF
- EM
- Accessories
- Tech. Info

Type	Image	$\varnothing D_1$	Image	Image	Shank Size $\varnothing D_2$	mm				EDP Number	★
						$\varnothing D$	L_1	L_2	L_4		
KSN 1/ Synchro	M4 - M12 (No.8 - 1/2)	4.5 - 10 mm 0.168 - 0.381	ER 20 (GB)	Hi-Q/ERC 20	25	34	42	57	5	F3131G26.1.24	★
KSN 3/ Synchro	M4 - M20 (1/4 - 3/4)	4.5 - 16 mm 0.255 - 0.590	ER 32 (GB)	Hi-Q/ERC 32	25	50	56	57	5	F3133G26.1.24	★
KSN 4/ Synchro	M10 - M30 (1/4 - 1)	7 - 22 mm 0.255 - 0.800	ER 40 (GB)	Hi-Q/ERC 40	25	63	65	57	5	F3134G26.1.24	★

1) Clamping depths E, see page 624 - 625

Further designs upon request

Clamping nut for sealing disks is included in the delivery

Accessories



Collets type ER (GB)

▶▶ 610 - 613



Sealing disks type DS/ER

▶▶ 616



Clamping wrench

▶▶ 622



Adapter shanks

▶▶ 604

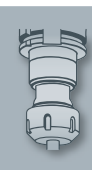

- Product Finder
- Soft-synchro
- Speed-synchro
- KSN**
- MQL
- SFM
- HF
- EM
- Accessories
- Tech. Info

KSN/Synchro

Weldon Shank

ASME B94.19

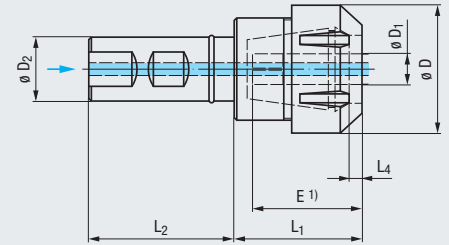
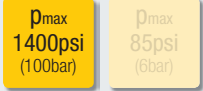
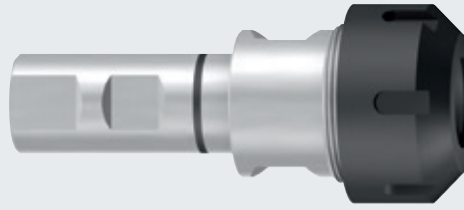



Type	Shank Size ø D ₂	ø D ₁	Collet	Shank Size ø D ₂	inch				EDP Number	★	
					ø D	L ₁	L ₂	L ₄			
KSN 1/ Synchro	M4 - M12 (No.8 - 1/2)	4.5 - 10 mm 0.168 - 0.381	ER 20 (GB)	Hi-Q/ERC 20	1	1.3386	1.6142	2.2835	0.1969	F3131H36.1.24	★
KSN 3/ Synchro	M4 - M20 (1/4 - 3/4)	4.5 - 16 mm 0.255 - 0.590	ER 32 (GB)	Hi-Q/ERC 32	1	1.9685	2.1654	2.2835	0.1969	F3133H36.1.24	★
KSN 4/ Synchro	M10 - M30 (1/4 - 1)	7 - 22 mm 0.255 - 0.800	ER 40 (GB)	Hi-Q/ERC 40	1	2.4803	2.5591	2.2835	0.1969	F3134H36.1.24	★

1) Clamping depths E, see page 624 - 625

Further designs upon request

Clamping nut for sealing disks is included in the delivery

Accessories

- 
Collets type ER (GB) ▶▶ 610 - 613
- 
Sealing disks type DS/ER ▶▶ 616
- 
Clamping wrench ▶▶ 622
- 
Adapter shanks ▶▶ 604

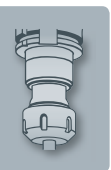

KSN/Synchro

SK Shank

DIN 69871 AD

DIN 69871 B

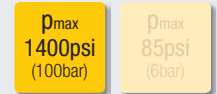
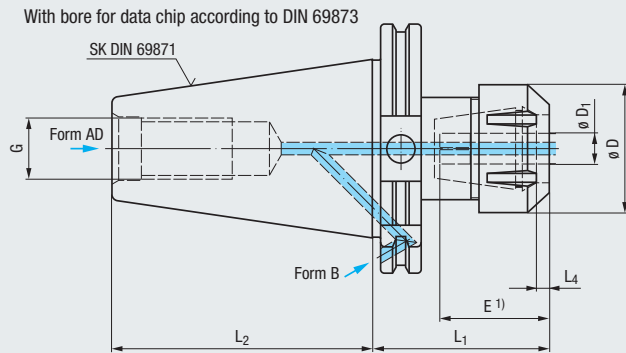

- Product Finder
- Soft-synchro
- Speed-synchro
- KSN**
- MQL
- SFM
- HF
- EM
- Accessories
- Tech. Info

Type		$\varnothing D_1$			Shank Size $\varnothing D_2$	$\varnothing D$	L_1	L_2	L_4	G	EDP Number	
KSN 0/Synchro	M1 - M10 (No.0 - No.10)	2.5 - 7 mm 0.141 - 0.194	ER 11 (GB)	Hi-Q/ERC 11	SK 40 AD	19	58	68.4	—	M16	F3130651.1	★
					SK 40 B	19	58	68.4	—	M16	F3130651.2	
					SK 50 AD	19	58	101.75	—	M24	F3130653.1	★
					SK 50 B	19	58	101.75	—	M24	F3130653.2	
KSN 1/Synchro	M4 - M12 (No.8 - 1/2)	4.5 - 10 mm 0.168 - 0.381	ER 20 (GB)	Hi-Q/ERC 20	SK 40 AD	34	68	68.4	5	M16	F3131651.1.24	★
					SK 40 B	34	68	68.4	5	M16	F3131651.2.24	★
					SK 50 AD	34	68	101.75	5	M24	F3131653.1.24	★
					SK 50 B	34	68	101.75	5	M24	F3131653.2.24	★
KSN 3/Synchro	M4 - M20 (1/4 - 3/4)	4.5 - 16 mm 0.255 - 0.590	ER 32 (GB)	Hi-Q/ERC 32	SK 40 AD	50	76	68.4	5	M16	F3133651.1.24	★
					SK 40 B	50	76	68.4	5	M16	F3133651.2.24	★
					SK 50 AD	50	76	101.75	5	M24	F3133653.1.24	★
					SK 50 B	50	76	101.75	5	M24	F3133653.2.24	★
KSN 4/Synchro	M10 - M30 (1/4 - 1)	7 - 22 mm 0.255 - 0.800	ER 40 (GB)	Hi-Q/ERC 40	SK 40 AD	63	85	68.4	5	M16	F3134651.1.24	★
					SK 40 B	63	85	68.4	5	M16	F3134651.2.24	★
					SK 50 AD	63	85	101.75	5	M24	F3134653.1.24	★
					SK 50 B	63	85	101.75	5	M24	F3134653.2.24	★

1) Clamping depths E, see page 624 - 625

Further designs upon request

KSN 0/Synchro

Clamping nut without integrated seal is included in the delivery

KSN 1-4/Synchro

Clamping nut for sealing disks is included in the delivery

Accessories



Collets type ER (GB)

▶▶ 610 - 613



Clamping nut with integrated seal, type Hi-Q/ERC 11

▶▶ 619



Sealing disks type DS/ER

▶▶ 616



Clamping wrench

▶▶ 622

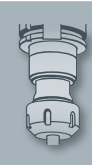

- Product Finder
- Soft-synchro
- Speed-synchro
- KSN
- MQL
- SFM
- HF
- EM
- Accessories
- Tech. Info

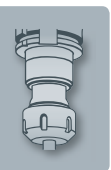
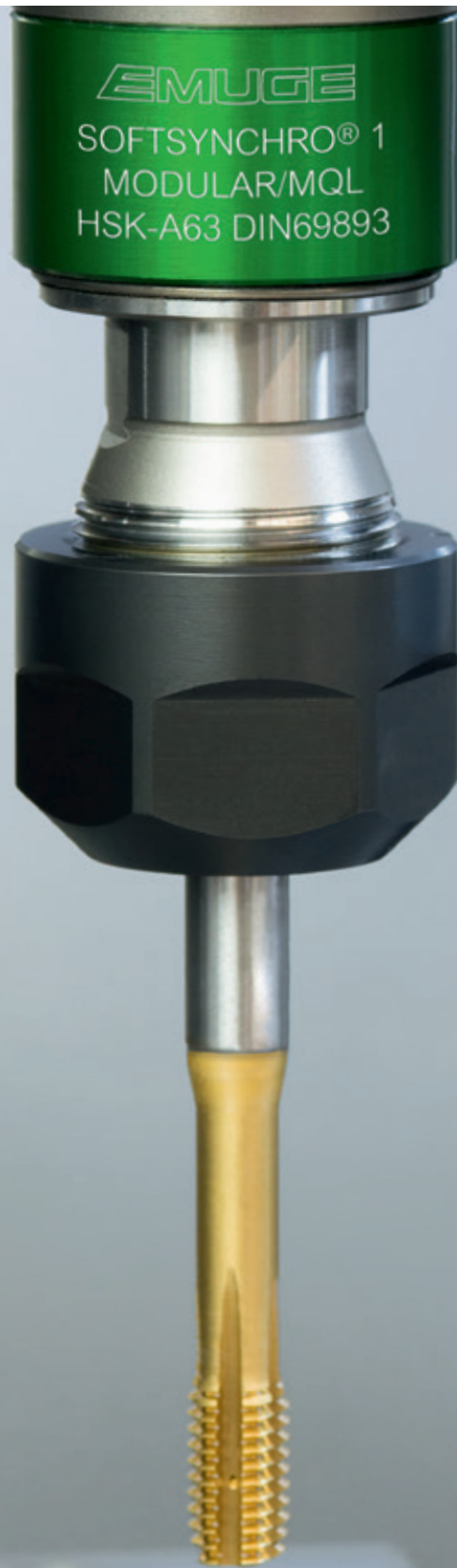

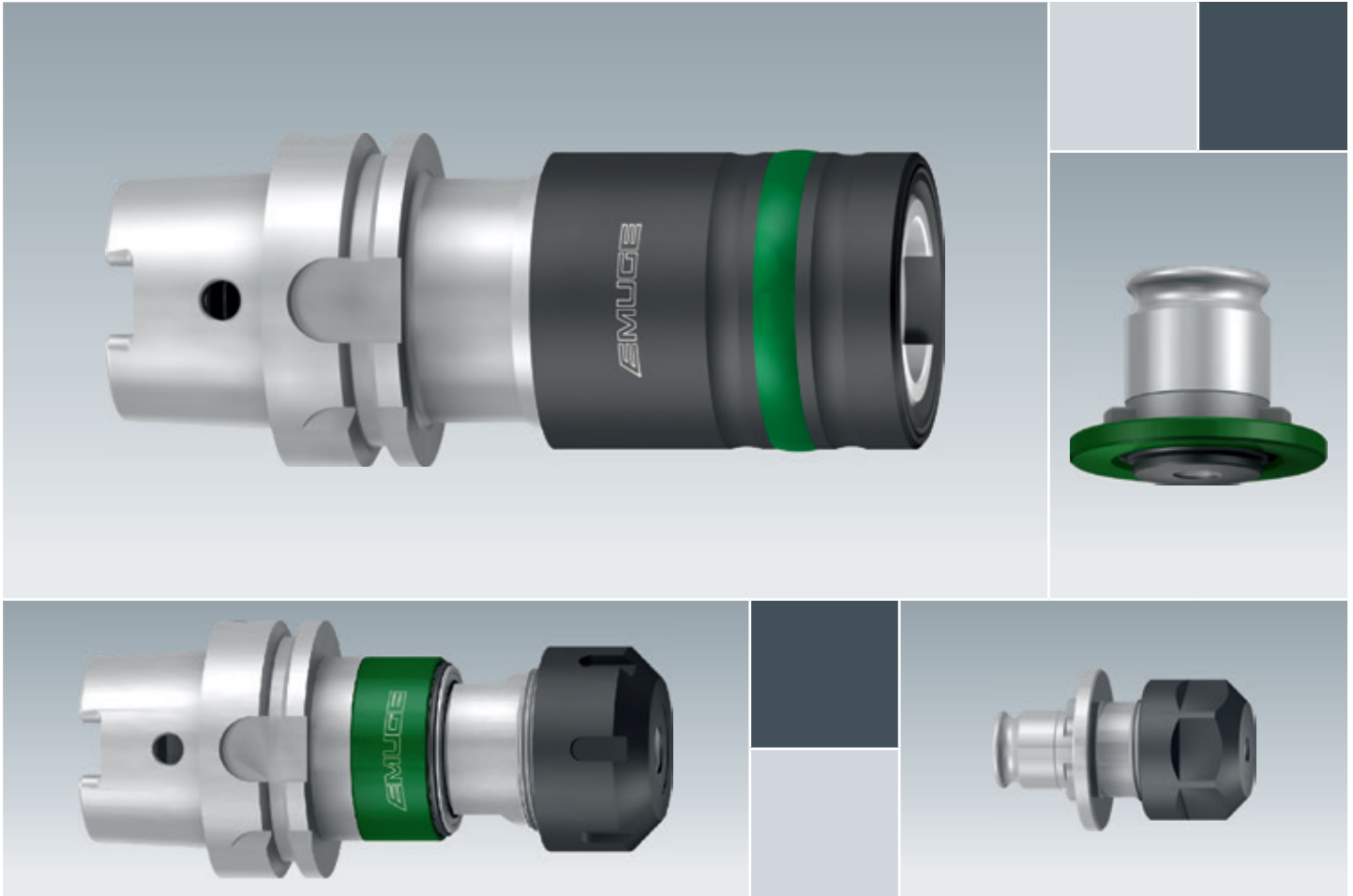

Minimum Quantity Lubrication Series

Application on machines with minimum-quantity lubrication (MQL)

Flow-optimized transfer of the MQL medium from machine spindle to threading tool.



Softsynchro®/MMS

HSK-A Shank

DIN 69893 A



For use on machines with synchronous spindle

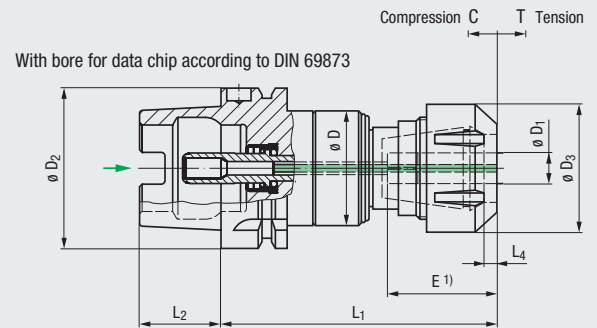

Type		$\varnothing D_1$			Shank Size $\varnothing D_2$	mm							EDP Number	
						$\varnothing D$	$\varnothing D_3$	L_1	L_2	L_4	C	T		
Softsynchro® 1/MMS	M4.5 - M10	6 - 8 mm	ER 20 (GB)	Hi-Q/ERC 20	HSK-A50	34	34	93.5	25	5	0.5	0.5	F3491C03.1.68	★
					HSK-A63	34	34	95.5	32	5	0.5	0.5	F3491C04.1.68	★
					HSK-A100	34	34	102	50	5	0.5	0.5	F3491C06.1.68	★
	M10 - M12	9 - 10 mm	ER 20 (GB)	Hi-Q/ERC 20	HSK-A50	34	34	93.5	25	5	0.5	0.5	F3491C03.1	★
					HSK-A63	34	34	95.5	32	5	0.5	0.5	F3491C04.1	★
					HSK-A100	34	34	102	50	5	0.5	0.5	F3491C06.1	★
Softsynchro® 3/MMS	M10 - M20	9 - 16 mm	ER 32 (GB)	Hi-Q/ERC 32	HSK-A50	45	50	116.3	25	5	0.5	0.5	F3493C03.1	★
					HSK-A63	45	50	108.8	32	5	0.5	0.5	F3493C04.1	★
					HSK-A100	45	50	115.3	50	5	0.5	0.5	F3493C06.1	★

1) Clamping depths E, see page 624 - 625

Further designs upon request

The coolant tube is integrated into the shank and must not be disassembled, otherwise the function of the MQL transfer is no longer warranted!

MQL supply according to DIN 69090-4 and many internal standards

Clamping nut for sealing disks is included in the delivery

Accessories



Collets type ER (GB)

» 610 - 613



Sealing disks type DS/ER

» 616



Set of clamping wrenches

» 621



Assembly device

» 621



Torque wrenches TORCO-FIX

» 623

Softsynchro®/MMS

HSK-A Shank

DIN 69893 A

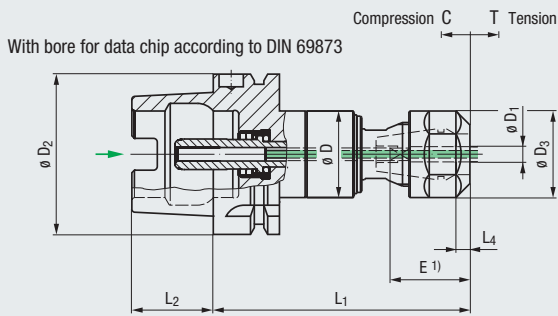
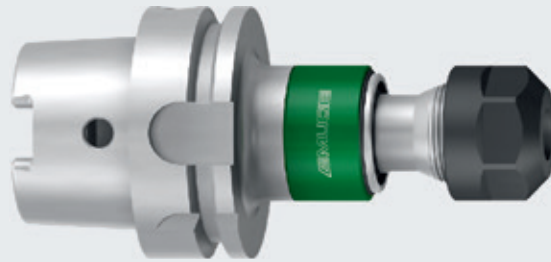

IKZ

MQL

MQL 2

p_{max}
700psi
(50bar)

p_{max}
85psi
(6bar)

C T
Soft

F

↔

For use on machines with synchronous spindle

Type		ø D ₁			Shank Size ø D ₂	mm						C	T	EDP Number	★
						ø D	ø D ₃	L ₁	L ₂	L ₄					
Softsynchro® 1/MMS	M4.5 - M12	6 - 10 mm	ER 20 (GB)	Hi-Q/ERC 20	HSK-A50	34	34	93.5	25	5	0.5	0.5	F3511C03.1	★	
					HSK-A63	34	34	95.5	32	5	0.5	0.5	F3511C04.1	★	
					HSK-A100	34	34	102	50	5	0.5	0.5	F3511C06.1	★	

1) Clamping depths E, see page 624 - 625

Further designs upon request

The coolant tube is integrated into the shank and must not be disassembled, otherwise the function of the MQL transfer is no longer warranted!

MQL supply according to DIN 69090-4 and many internal standards

Clamping nut for sealing disks is included in the delivery

Accessories



Collets type ER (GB)

» 610 - 613



Sealing disks type DS/ER

» 616



Set of clamping wrenches

» 621



Assembly device

» 621



Torque wrenches TORCO-FIX

» 623

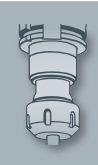

- Product Finder
- Soft-synchro
- Speed-synchro
- KSN
- MQL
- SFM
- HF
- EM
- Accessories
- Tech. Info

Softsynchro®/MMS

HSK-C Shank

≈ DIN 69893 C 2)

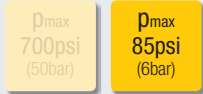
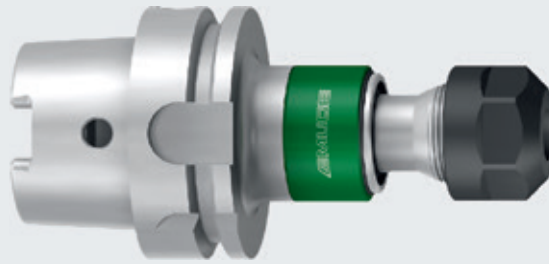

For use on machines with synchronous spindle

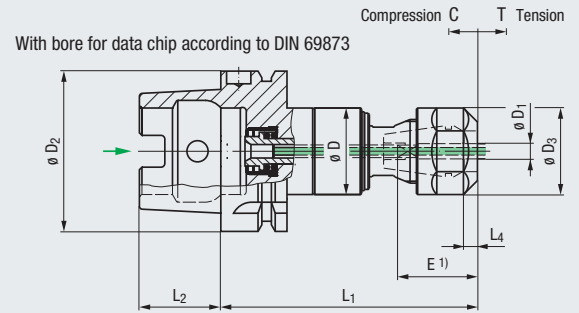

Type	Collet	ø D ₁	Collet	Shank Size ø D ₂	mm							EDP Number	★	
					ø D	ø D ₃	L ₁	L ₂	L ₄	C	T			
Softsynchro® 1/MMS	M4.5 - M10	6 - 8 mm	ER 20 (GB)	Hi-Q/ERC 20	HSK-A63	34	34	95.5	32	5	0.5	0.5	F3491C04.1.5268	★
	M10 - M12	9 - 10 mm			HSK-A63	34	34	95.5	32	5	0.5	0.5	F3491C04.1.52	★

1) Clamping depths E, see page 624 - 625

Further designs upon request

2) Outside contour acc. DIN 69893 A, inside contour acc. DIN 69893 C

The coolant tube is integrated into the shank and must not be disassembled, otherwise the function of the MQL transfer is no longer warranted!

MQL supply according to DIN 69090-4 and many internal standards

Clamping nut for sealing disks is included in the delivery

Accessories



Collets type ER (GB)

» 610 - 613



Sealing disks type DS/ER

» 616



Set of clamping wrenches

» 621



Assembly device

» 621



Torque wrenches TORCO-FIX

» 623

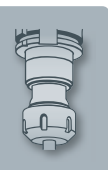



EMUGE
SOFTSYNCHRO[®] 1
MODULAR/MQL
HSK-A/C 63 DIN69893



Softsynchro® Modular/MQL

HSK-A Shank

DIN 69893 A

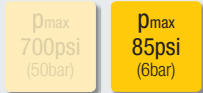
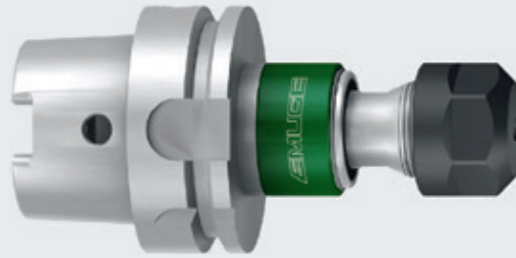

For use on machines with synchronous spindle

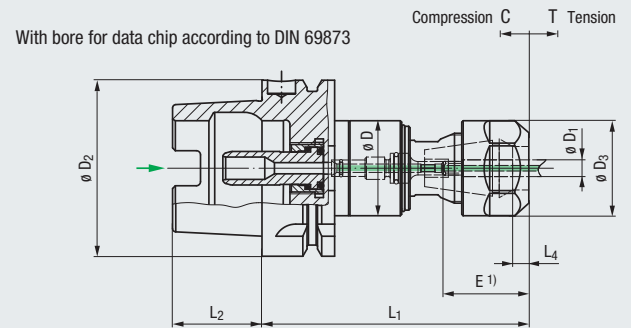

new	Type	ϕD_1	Tool Taper	Shank Size ϕD_2	mm							EDP Number				
					ϕD	ϕD_3	L_1	L_2	L_4	C	T					
Softsynchro® 1 Modular/MQL	M4.5 - M10	6 / 7 mm	Internal taper 60°	ER 20 (GB)	Hi-Q/ERC 20	HSK-A40	34	34	89.5	20	5	0.5	0.5	F3551C02.53.I01	★	
						HSK-A63	34	34	95.5	32	5	0.5	0.5	F3551C04.53.I01	★	
						HSK-A100	34	34	102	50	5	0.5	0.5	F3551C06.53.I01	★	
	M8, M9, M11, M12	8 / 9 mm	Internal taper 60°	ER 20 (GB)	Hi-Q/ERC 20	HSK-A40	34	34	89.5	20	5	0.5	0.5	F3551C02.53.I02	★	
						HSK-A63	34	34	95.5	32	5	0.5	0.5	F3551C04.53.I02	★	
						HSK-A100	34	34	102	50	5	0.5	0.5	F3551C06.53.I02	★	
	M10	10 mm	Internal taper 60°	ER 20 (GB)	Hi-Q/ERC 20	HSK-A40	34	34	89.5	20	5	0.5	0.5	F3551C02.53.I03	★	
						HSK-A63	34	34	95.5	32	5	0.5	0.5	F3551C04.53.I03	★	
						HSK-A100	34	34	102	50	5	0.5	0.5	F3551C06.53.I03	★	
	M4.5 - M6 M8	6 mm	External taper 90°	ER 20 (GB)	Hi-Q/ERC 20	HSK-A40	34	34	89.5	20	5	0.5	0.5	F3551C02.53.A04	★	
						HSK-A63	34	34	95.5	32	5	0.5	0.5	F3551C04.53.A04	★	
						HSK-A100	34	34	102	50	5	0.5	0.5	F3551C06.53.A04	★	
		M7, M10	7 mm	External taper 90°	ER 20 (GB)	Hi-Q/ERC 20	HSK-A40	34	34	89.5	20	5	0.5	0.5	F3551C02.53.A05	★
							HSK-A63	34	34	95.5	32	5	0.5	0.5	F3551C04.53.A05	★
							HSK-A100	34	34	102	50	5	0.5	0.5	F3551C06.53.A05	★
		M8	8 mm	External taper 90°	ER 20 (GB)	Hi-Q/ERC 20	HSK-A40	34	34	89.5	20	5	0.5	0.5	F3551C02.53.A06	★
							HSK-A63	34	34	95.5	32	5	0.5	0.5	F3551C04.53.A06	★
							HSK-A100	34	34	102	50	5	0.5	0.5	F3551C06.53.A06	★
		M12	9 mm	External taper 90°	ER 20 (GB)	Hi-Q/ERC 20	HSK-A40	34	34	89.5	20	5	0.5	0.5	F3551C02.53.A07	★
							HSK-A63	34	34	95.5	32	5	0.5	0.5	F3551C04.53.A07	★
HSK-A100							34	34	102	50	5	0.5	0.5	F3551C06.53.A07	★	
M10	10 mm	External taper 90°	ER 20 (GB)	Hi-Q/ERC 20	HSK-A40	34	34	89.5	20	5	0.5	0.5	F3551C02.53.A08	★		
					HSK-A63	34	34	95.5	32	5	0.5	0.5	F3551C04.53.A08	★		
					HSK-A100	34	34	102	50	5	0.5	0.5	F3551C06.53.A08	★		

1) Clamping depths E, see page 624 - 625

Coolant tube, length adjustment screw as well as clamping nut for sealing disks are included in the delivery

MQL supply according to DIN 69090-4 and many internal standards

Softsynchro® Modular/MQL

HSK-A Shank

DIN 69893 A

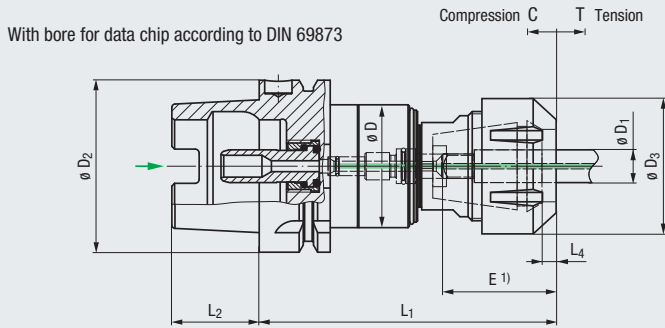
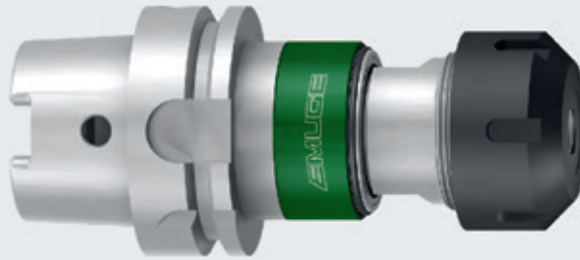

IKZ

MQL

MQL 1

p_{max}
700psi
(50bar)

p_{max}
85psi
(6bar)

C T
Soft

F

L+ 2 mm

[Icon]

[Icon]

[Icon]

For use on machines with synchronous spindle

new															
Type		$\varnothing D_1$	Tool Taper			Shank Size $\varnothing D_2$	mm						EDP Number		
						$\varnothing D$	$\varnothing D_3$	L_1	L_2	L_4	C	T			
Softsynchro® 3 Modular/MQL	M12	9 mm	Internal taper 60° 	ER 32 (GB)	Hi-Q/ERC 32	HSK-A63	45	50	108.8	32	5	0.5	0.5	F3553C04.53.I01	★
	HSK-A100	50				50	115.3	50	5	0.5	0.5	F3553C06.53.I01	★		
	M10 - M16	10 - 12 mm				HSK-A63	45	50	108.8	32	5	0.5	0.5	F3553C04.53.I02	★
	HSK-A100	50				50	115.3	50	5	0.5	0.5	F3553C06.53.I02	★		
	M18 - M20	14 - 16 mm	External taper 90° 	ER 32 (GB)	Hi-Q/ERC 32	HSK-A63	45	50	108.8	32	5	0.5	0.5	F3553C04.53.I03	★
	HSK-A100	50				50	115.3	50	5	0.5	0.5	F3553C06.53.I03	★		
	M12	9 mm				HSK-A63	45	50	108.8	32	5	0.5	0.5	F3553C04.53.A04	★
	HSK-A100	50				50	115.3	50	5	0.5	0.5	F3553C06.53.A04	★		
	M10	10 mm				HSK-A63	45	50	108.8	32	5	0.5	0.5	F3553C04.53.A05	★
	HSK-A100	50				50	115.3	50	5	0.5	0.5	F3553C06.53.A05	★		
	M14 - M16	11 - 12 mm	HSK-A63	45	50	108.8	32	5	0.5	0.5	F3553C04.53.A06	★			
	HSK-A100	50	50	115.3	50	5	0.5	0.5	F3553C06.53.A06	★					
	M18	14 mm	HSK-A63	45	50	108.8	32	5	0.5	0.5	F3553C04.53.A07	★			
	HSK-A100	50	50	115.3	50	5	0.5	0.5	F3553C06.53.A07	★					
M20	16 mm	HSK-A63	45	50	108.8	32	5	0.5	0.5	F3553C04.53.A08	★				
HSK-A100	50	50	115.3	50	5	0.5	0.5	F3553C06.53.A08	★						

1) Clamping depths E, see page 624 - 625

Accessories

Collets type ER (GB) ▶▶ 610 - 613

 Sealing disks type DS/ER ▶▶ 616

 Length adjustment screws ▶▶ 608

Set of clamping wrenches ▶▶ 621

 Assembly device ▶▶ 621

 Torque wrenches TORCO-FIX ▶▶ 623

 Coolant tubes and wrenches ▶▶ 606 - 607



Softsynchro® Modular/MQL

HSK-A Shank

DIN 69893 A

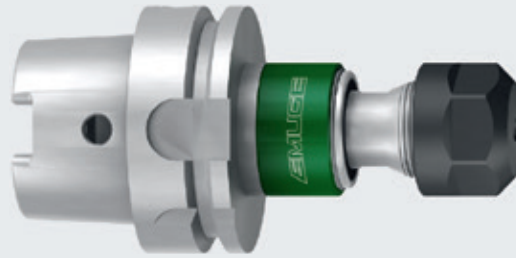

For use on machines with synchronous spindle

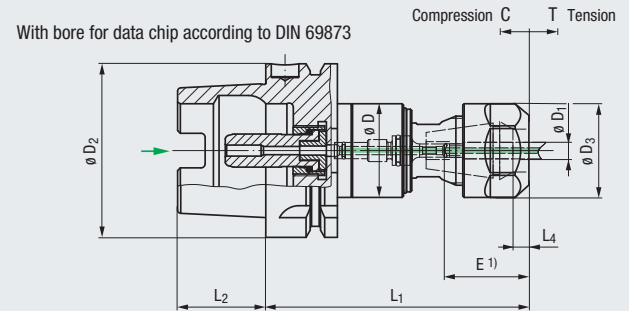

new	Type	θD_1	Tool taper	Shank Size θD_2	mm							EDP Number				
					θD	θD_3	L_1	L_2	L_4	C	T					
Softsynchro® 1 Modular/MQL	M4.5 - M10	6 / 7 mm	Internal taper 60°	ER 20 (GB)	Hi-Q/ERC 20	HSK-A40	34	34	89.5	20	5	0.5	0.5	F3551C02.54.I01	★	
						HSK-A63	34	34	95.5	32	5	0.5	0.5	F3551C04.54.I01	★	
						HSK-A100	34	34	102	50	5	0.5	0.5	F3551C06.54.I01	★	
	M8, M9, M11, M12	8 / 9 mm	Internal taper 60°	ER 20 (GB)	Hi-Q/ERC 20	HSK-A40	34	34	89.5	20	5	0.5	0.5	F3551C02.54.I02	★	
						HSK-A63	34	34	95.5	32	5	0.5	0.5	F3551C04.54.I02	★	
						HSK-A100	34	34	102	50	5	0.5	0.5	F3551C06.54.I02	★	
	M10	10 mm	Internal taper 60°	ER 20 (GB)	Hi-Q/ERC 20	HSK-A40	34	34	89.5	20	5	0.5	0.5	F3551C02.54.I03	★	
						HSK-A63	34	34	95.5	32	5	0.5	0.5	F3551C04.54.I03	★	
						HSK-A100	34	34	102	50	5	0.5	0.5	F3551C06.54.I03	★	
	M4.5 - M6 M8	6 mm	External taper 90°	ER 20 (GB)	Hi-Q/ERC 20	HSK-A40	34	34	89.5	20	5	0.5	0.5	F3551C02.54.A04	★	
						HSK-A63	34	34	95.5	32	5	0.5	0.5	F3551C04.54.A04	★	
						HSK-A100	34	34	102	50	5	0.5	0.5	F3551C06.54.A04	★	
		M7, M10	7 mm	External taper 90°	ER 20 (GB)	Hi-Q/ERC 20	HSK-A40	34	34	89.5	20	5	0.5	0.5	F3551C02.54.A05	★
							HSK-A63	34	34	95.5	32	5	0.5	0.5	F3551C04.54.A05	★
							HSK-A100	34	34	102	50	5	0.5	0.5	F3551C06.54.A05	★
		M8	8 mm	External taper 90°	ER 20 (GB)	Hi-Q/ERC 20	HSK-A40	34	34	89.5	20	5	0.5	0.5	F3551C02.54.A06	★
							HSK-A63	34	34	95.5	32	5	0.5	0.5	F3551C04.54.A06	★
							HSK-A100	34	34	102	50	5	0.5	0.5	F3551C06.54.A06	★
		M12	9 mm	External taper 90°	ER 20 (GB)	Hi-Q/ERC 20	HSK-A40	34	34	89.5	20	5	0.5	0.5	F3551C02.54.A07	★
							HSK-A63	34	34	95.5	32	5	0.5	0.5	F3551C04.54.A07	★
HSK-A100							34	34	102	50	5	0.5	0.5	F3551C06.54.A07	★	
M10	10 mm	External taper 90°	ER 20 (GB)	Hi-Q/ERC 20	HSK-A40	34	34	89.5	20	5	0.5	0.5	F3551C02.54.A08	★		
					HSK-A63	34	34	95.5	32	5	0.5	0.5	F3551C04.54.A08	★		
					HSK-A100	34	34	102	50	5	0.5	0.5	F3551C06.54.A08	★		

1) Clamping depths E, see page 624 - 625

Coolant tube, length adjustment screw as well as clamping nut for sealing disks are included in the delivery

MQL supply according to DIN 69090-4 and many internal standards

Softsynchro® Modular/MQL

HSK-A Shank

DIN 69893 A

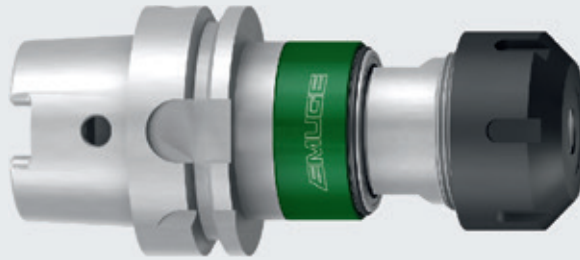

With bore for data chip according to DIN 69873

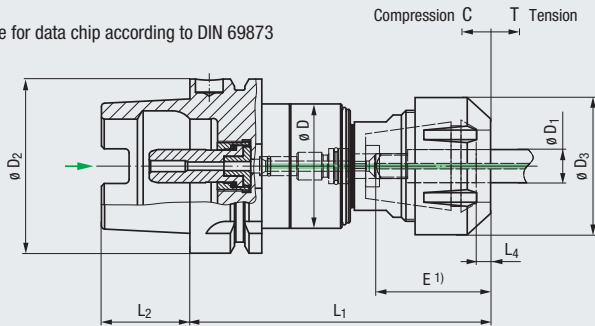

IKZ

MQL

MQL 2

p_{max}
700psi
(50bar)

p_{max}
85psi
(6bar)

C Soft

F

L+ 2 mm

[Icon]

[Icon]

[Icon]

For use on machines with synchronous spindle

new	Type	$\varnothing D_1$	Tool Taper	Shank Size $\varnothing D_2$	mm							EDP Number			
					$\varnothing D$	$\varnothing D_3$	L_1	L_2	L_4	C	T				
Softsynchro® 3 Modular/MQL	M12	9 mm	Internal taper 60°	ER 32 (GB)	Hi-Q/ERC 32	HSK-A63	45	50	108.8	32	5	0.5	0.5	F3553C04.54.I01	★
						HSK-A100	50	50	115.3	50	5	0.5	0.5	F3553C06.54.I01	★
	M10 - M16	10 - 12 mm				HSK-A63	45	50	108.8	32	5	0.5	0.5	F3553C04.54.I02	★
			HSK-A100			50	50	115.3	50	5	0.5	0.5	F3553C06.54.I02	★	
	M18 - M20	14 - 16 mm	HSK-A63			45	50	108.8	32	5	0.5	0.5	F3553C04.54.I03	★	
			HSK-A100			50	50	115.3	50	5	0.5	0.5	F3553C06.54.I03	★	
	M12	9 mm	External taper 90°	ER 32 (GB)	Hi-Q/ERC 32	HSK-A63	45	50	108.8	32	5	0.5	0.5	F3553C04.54.A04	★
						HSK-A100	50	50	115.3	50	5	0.5	0.5	F3553C06.54.A04	★
	M10	10 mm				HSK-A63	45	50	108.8	32	5	0.5	0.5	F3553C04.54.A05	★
						HSK-A100	50	50	115.3	50	5	0.5	0.5	F3553C06.54.A05	★
	M14 - M16	11 - 12 mm				HSK-A63	45	50	108.8	32	5	0.5	0.5	F3553C04.54.A06	★
						HSK-A100	50	50	115.3	50	5	0.5	0.5	F3553C06.54.A06	★
	M18	14 mm				HSK-A63	45	50	108.8	32	5	0.5	0.5	F3553C04.54.A07	★
						HSK-A100	50	50	115.3	50	5	0.5	0.5	F3553C06.54.A07	★
M20	16 mm	HSK-A63	45	50	108.8	32	5	0.5	0.5	F3553C04.54.A08	★				
		HSK-A100	50	50	115.3	50	5	0.5	0.5	F3553C06.54.A08	★				

1) Clamping depths E, see page 624 - 625

Accessories

Collets type ER (GB) ▶▶ 610 - 613

Sealing disks type DS/ER ▶▶ 616

Length adjustment screws ▶▶ 608

Set of clamping wrenches ▶▶ 621

Assembly device ▶▶ 621

Torque wrenches TORCO-FIX ▶▶ 623

Coolant tubes and wrenches ▶▶ 606 - 607



Softsynchro® Modular/MQL

HSK-C Shank

≈ DIN 69893 C 2)

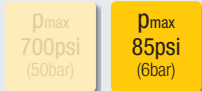
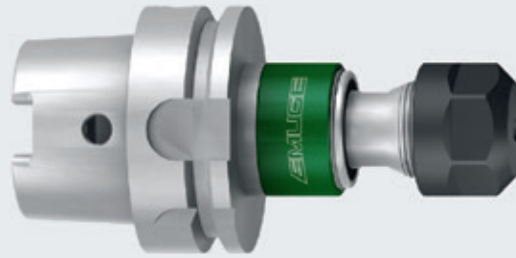

For use on machines with synchronous spindle

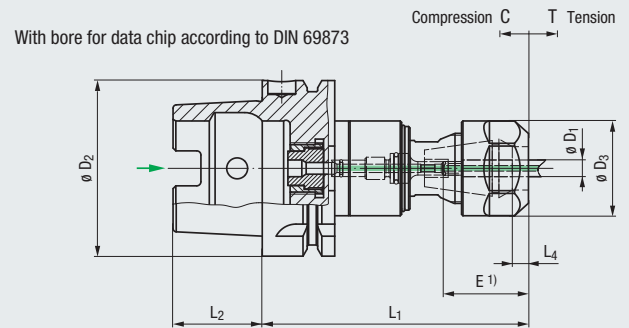

new	Type	ϕD_1	Tool Taper	Shank Size ϕD_2	mm							EDP Number				
					ϕD	ϕD_3	L_1	L_2	L_4	C	T					
Softsynchro® 1 Modular/MQL	M4.5 - M10	6 / 7 mm	Internal taper 60°	ER 20 (GB)	Hi-Q/ERC 20	HSK-A40	34	34	89.5	20	5	0.5	0.5	F3551C02.52.I01	★	
						HSK-A63	34	34	95.5	32	5	0.5	0.5	F3551C04.52.I01	★	
						HSK-A100	34	34	102	50	5	0.5	0.5	F3551C06.52.I01	★	
	M8, M9, M11, M12	8 / 9 mm	Internal taper 60°	ER 20 (GB)	Hi-Q/ERC 20	HSK-A40	34	34	89.5	20	5	0.5	0.5	F3551C02.52.I02	★	
						HSK-A63	34	34	95.5	32	5	0.5	0.5	F3551C04.52.I02	★	
						HSK-A100	34	34	102	50	5	0.5	0.5	F3551C06.52.I02	★	
	M10	10 mm	Internal taper 60°	ER 20 (GB)	Hi-Q/ERC 20	HSK-A40	34	34	89.5	20	5	0.5	0.5	F3551C02.52.I03	★	
						HSK-A63	34	34	95.5	32	5	0.5	0.5	F3551C04.52.I03	★	
						HSK-A100	34	34	102	50	5	0.5	0.5	F3551C06.52.I03	★	
	M4.5 - M6 M8	6 mm	External taper 90°	ER 20 (GB)	Hi-Q/ERC 20	HSK-A40	34	34	89.5	20	5	0.5	0.5	F3551C02.52.A04	★	
						HSK-A63	34	34	95.5	32	5	0.5	0.5	F3551C04.52.A04	★	
						HSK-A100	34	34	102	50	5	0.5	0.5	F3551C06.52.A04	★	
		M7, M10	7 mm	External taper 90°	ER 20 (GB)	Hi-Q/ERC 20	HSK-A40	34	34	89.5	20	5	0.5	0.5	F3551C02.52.A05	★
							HSK-A63	34	34	95.5	32	5	0.5	0.5	F3551C04.52.A05	★
							HSK-A100	34	34	102	50	5	0.5	0.5	F3551C06.52.A05	★
		M8	8 mm	External taper 90°	ER 20 (GB)	Hi-Q/ERC 20	HSK-A40	34	34	89.5	20	5	0.5	0.5	F3551C02.52.A06	★
							HSK-A63	34	34	95.5	32	5	0.5	0.5	F3551C04.52.A06	★
							HSK-A100	34	34	102	50	5	0.5	0.5	F3551C06.52.A06	★
		M12	9 mm	External taper 90°	ER 20 (GB)	Hi-Q/ERC 20	HSK-A40	34	34	89.5	20	5	0.5	0.5	F3551C02.52.A07	★
							HSK-A63	34	34	95.5	32	5	0.5	0.5	F3551C04.52.A07	★
							HSK-A100	34	34	102	50	5	0.5	0.5	F3551C06.52.A07	★
	M10	10 mm	External taper 90°	ER 20 (GB)	Hi-Q/ERC 20	HSK-A40	34	34	89.5	20	5	0.5	0.5	F3551C02.52.A08	★	
						HSK-A63	34	34	95.5	32	5	0.5	0.5	F3551C04.52.A08	★	
						HSK-A100	34	34	102	50	5	0.5	0.5	F3551C06.52.A08	★	

1) Clamping depths E, see page 624 - 625

2) Outside contour acc. DIN 69893 A, inside contour acc. DIN 69893 C

Adapter, length adjustment screw as well as clamping nut for sealing disks are included in the delivery

MQL supply according to DIN 69090-4 and many internal standards

Softsynchro® Modular/MQL

HSK-C Shank

≈ DIN 69893 C 2)

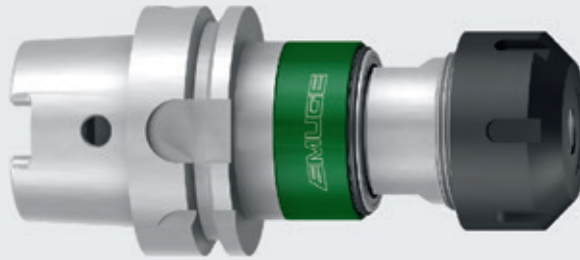

With bore for data chip according to DIN 69873

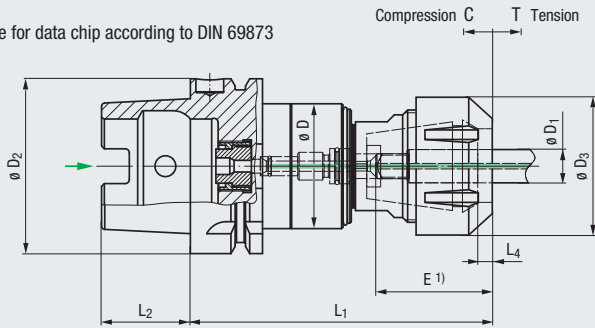

IKZ

MQL

MQL 1

p_{max}
700psi
(50bar)

p_{max}
85psi
(6bar)

C Soft

F

L+ 2 mm

[Icon]

[Icon]

[Icon]

For use on machines with synchronous spindle

new	Type	$\varnothing D_1$	Tool Taper	Shank Size $\varnothing D_2$	mm							EDP Number		
					$\varnothing D$	$\varnothing D_3$	L_1	L_2	L_4	C	T			
Softsynchro® 3 Modular/MQL	M12	9 mm	Internal taper 60°	ER 32 (GB) Hi-Q/ERC 32	HSK-A63	45	50	108.8	32	5	0.5	0.5	F3553C04.52.I01	★
					HSK-A100	50	50	115.3	50	5	0.5	0.5	F3553C06.52.I01	★
	M10 - M16	10 - 12 mm			HSK-A63	45	50	108.8	32	5	0.5	0.5	F3553C04.52.I02	★
					HSK-A100	50	50	115.3	50	5	0.5	0.5	F3553C06.52.I02	★
	M18 - M20	14 - 16 mm			HSK-A63	45	50	108.8	32	5	0.5	0.5	F3553C04.52.I03	★
					HSK-A100	50	50	115.3	50	5	0.5	0.5	F3553C06.52.I03	★
	M12	9 mm	External taper 90°	ER 32 (GB) Hi-Q/ERC 32	HSK-A63	45	50	108.8	32	5	0.5	0.5	F3553C04.52.A04	★
					HSK-A100	50	50	115.3	50	5	0.5	0.5	F3553C06.52.A04	★
	M10	10 mm			HSK-A63	45	50	108.8	32	5	0.5	0.5	F3553C04.52.A05	★
					HSK-A100	50	50	115.3	50	5	0.5	0.5	F3553C06.52.A05	★
	M14 - M16	11 - 12 mm			HSK-A63	45	50	108.8	32	5	0.5	0.5	F3553C04.52.A06	★
					HSK-A100	50	50	115.3	50	5	0.5	0.5	F3553C06.52.A06	★
	M18	14 mm			HSK-A63	45	50	108.8	32	5	0.5	0.5	F3553C04.52.A07	★
					HSK-A100	50	50	115.3	50	5	0.5	0.5	F3553C06.52.A07	★
M20	16 mm			HSK-A63	45	50	108.8	32	5	0.5	0.5	F3553C04.52.A08	★	
				HSK-A100	50	50	115.3	50	5	0.5	0.5	F3553C06.52.A08	★	

1) Clamping depths E, see page 624 - 625

Accessories

Collets type ER (GB) ▶▶ 610 - 613

Sealing disks type DS/ER ▶▶ 616

Length adjustment screws ▶▶ 608

Set of clamping wrenches ▶▶ 621

Assembly device ▶▶ 621

Torque wrenches TORCO-FIX ▶▶ 623

Adapter ▶▶ 607



Speedsynchro® Modular/MQL

ABS® Shank

ABS®-clutch (System KOMET)

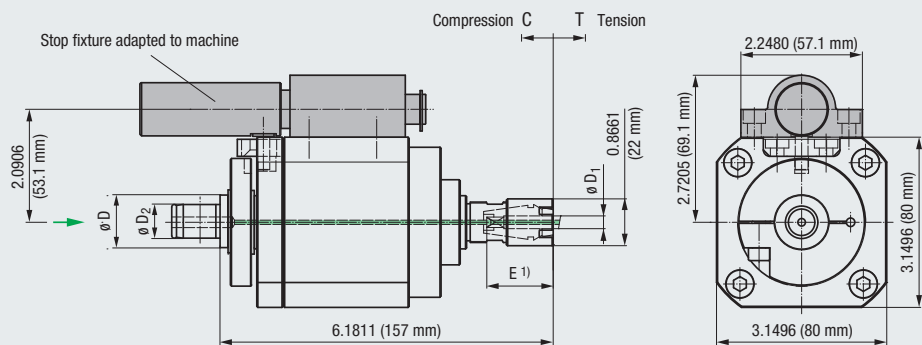
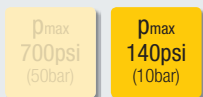

For use on machines with synchronous spindle

new	Type	M1 - M8	ER 16 (GB)	Hi-Q/ERMC 16	mm			Max. Spindle Speed	Transmission Ratio	mm		EDP Number	
					ø D	ø D ₂	ø D ₁			C	T		
	Speedsynchro® Modular/MQL	M1 - M8	ER 16 (GB)	Hi-Q/ERMC 16	ABS 32	16	2.5 - 8	2000	1:4.412	0.5	0.5	F3751L01	●

1) Clamping depths E, see page 624 - 625

Adapter shank, stop fixture (see also page 646) and length adjustment screw are not included in the delivery, please order separately

Accessories



Adapter shanks

» 605



Assembly device

» 621



Collets type ER (GB)

» 610 - 613



Length adjustment screws

» 609



Sealing disks type DS/ER

» 616

KSN/MQL
HSK-A Shank
 DIN 69893 A

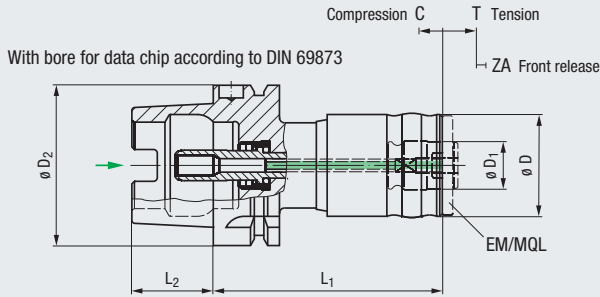
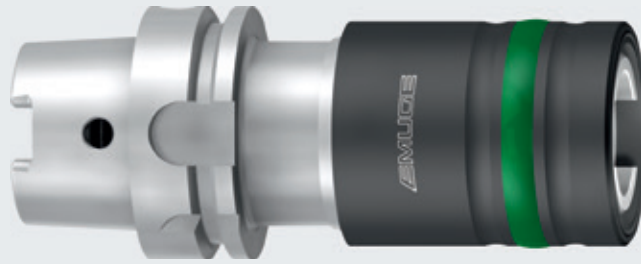

Product Finder

- Soft-synchro
- Speed-synchro
- KSN
- MQL**
- SFM
- HF
- EM
- Accessories
- Tech. Info

IKZ

MQL

MQL 1

p_{max} 700psi (50bar)

p_{max} 85psi (6bar)

C T

F

EM/MQL

For use on CNC machining centers and other machine tools

Type			Shank Size $\varnothing D_2$	mm							EDP Number	
				$\varnothing D$	$\varnothing D_1$	L_1	L_2	C	T	ZA		
KSN 1/MQL	M6 - M12	EM 01/MQL	HSK-A40	40	19	88	20	5	5	2.5	F3471C02.1	★
			HSK-A50	40	19	90	25	5	5	2.5	F3471C03.1	★
			HSK-A63	40	19	90	32	5	5	2.5	F3471C04.1	★
			HSK-A80	40	19	93	40	5	5	2.5	F3471C05.1	★
			HSK-A100	40	19	93	50	5	5	2.5	F3471C06.1	★
KSN 3/MQL	M10 - M24	EM 03/MQL	HSK-A63	56	31	120	32	7	7	3	F3473C04.1	★
			HSK-A80	56	31	125	40	7	7	3	F3473C05.1	★
			HSK-A100	56	31	128	50	7	7	3	F3473C06.1	★

The coolant tube is integrated into the shank and must not be disassembled, otherwise the function of the MQL transfer is no longer warranted!

Further designs upon request

MQL supply according to DIN 69090-4 and many internal standards

Accessories



Quick-change adapters type EM/MQL

» 562



Quick-change adapters type EM-Z/MQL

» 563 - 564



- Product Finder
- Soft-synchro
- Speed-synchro
- KSN
- MQL**
- SFM
- HF
- EM
- Accessories
- Tech. Info

KSN/MQL

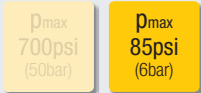
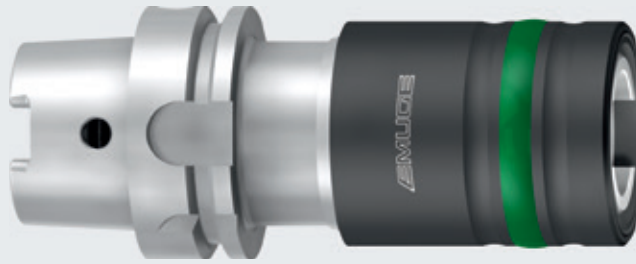

HSK-A Shank

DIN 69893 A

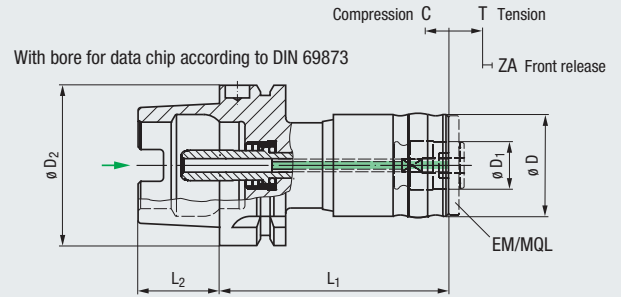

For use on CNC machining centers and other machine tools



Type			Shank Size $\varnothing D_2$	mm							EDP Number	
				$\varnothing D$	$\varnothing D_1$	L_1	L_2	C	T	ZA		
KSN 1/MQL	M6 - M12	EM 01/MQL	HSK-A40	40	19	88	20	5	5	2.5	F3481C02.1	★
			HSK-A50	40	19	90	25	5	5	2.5	F3481C03.1	★
			HSK-A63	40	19	90	32	5	5	2.5	F3481C04.1	★
			HSK-A80	40	19	93	40	5	5	2.5	F3481C05.1	★
			HSK-A100	40	19	93	50	5	5	2.5	F3481C06.1	★

The coolant tube is integrated into the shank and must not be disassembled, otherwise the function of the MQL transfer is no longer warranted!

Further designs upon request

MQL supply according to DIN 69090-4 and many internal standards

Accessories



Quick-change adapters type EM/MQL ▶▶ 562



Quick-change adapters type EM-Z/MQL ▶▶ 563

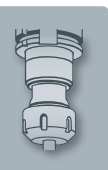

KSN/MQL

HSK-C Shank

≈ DIN 69893 C 2)

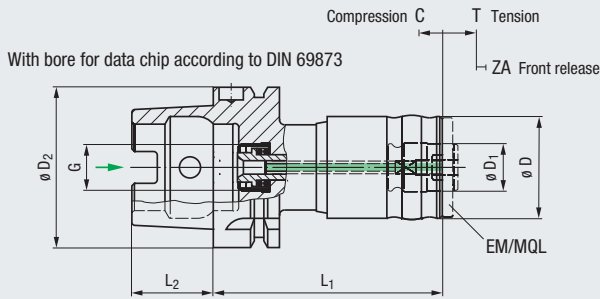
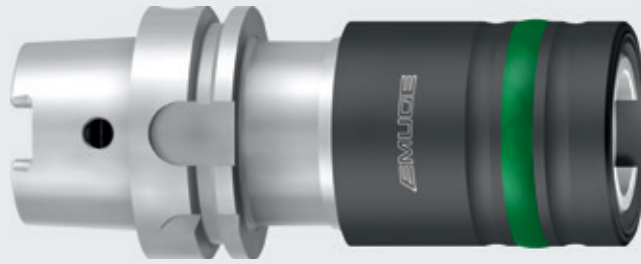

IKZ

MQL

MQL 1

p_{max} 700psi (50bar)

p_{max} 85psi (6bar)

C T

F

↔

[Image]

[Image]

[Image]

For use on CNC machining centers and other machine tools

Type	Thread	Adapter	Shank Size ϕD_2	mm							EDP Number	
				ϕD	ϕD_1	L_1	L_2	C	T	ZA		
KSN 1/MQL	M6 - M12	EM 01/MQL	HSK-A40	40	19	88	20	5	5	2.5	F3471C02.1.52	★
			HSK-A50	40	19	90	25	5	5	2.5	F3471C03.1.52	★
			HSK-A63	40	19	90	32	5	5	2.5	F3471C04.1.52	★
KSN 3/MQL	M10 - M24	EM 03/MQL	HSK-A63	56	31	120	32	7	7	3	F3473C04.1.52	★
			HSK-A80	56	31	125	40	7	7	3	F3473C05.1.52	★
			HSK-A100	56	31	128	50	7	7	3	F3473C06.1.52	★

1) Outside contour acc. DIN 69893 A, inside contour acc. DIN 69893 C

Further designs upon request

The coolant tube is integrated into the shank and must not be disassembled, otherwise the function of the MQL transfer is no longer warranted!

MQL supply according to DIN 69090-4 and many internal standards

Accessories



Quick-change adapters type EM/MQL → 562



Quick-change adapters type EM-Z/MQL → 563 - 564



- Product Finder
- Soft-synchro
- Speed-synchro
- KSN
- SQL**
- SFM
- HF
- EM
- Accessories
- Tech. Info

EM/MQL

Metric

DIN

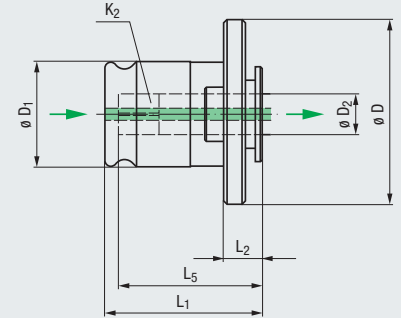
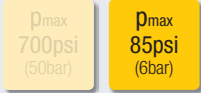

Type		EM 01/MQL		EM 03/MQL							
		M6 - M12		M10 - M24							
Quick-Change Adapter Dimensions (mm)		θD		39		55					
		θD_1		19		31					
		L_1		29		45					
		L_2		7.5		10					
mm				EDP Number		L_5					
θD_2	K_2										
6	4.9	M6	M8	F4491106.6	25	★					
7	5.5	M7	M9 - M10	F4491107.6	25	★					
8	6.2	M8	M11	F4491108.6	26	★					
9	7	M9	M12	F4491109.6	27	★					
10	8	M10		F4491110.6	27	★	F4493110.6	40	★		
11	9		M14				F4493111.6	41	★		
12	9		M16				F4493112.6	41	★		
14	11		M18				F4493113.6	43	★		
16	12		M20				F4493114.6	44	★		
18	14.5		M22 - M24				F4493115.6	44	★		

1) If used with taps / roll form taps with internal coolant supply

Only suitable for quick-change tap holders type KSN/MQL

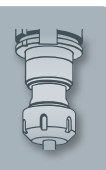

EM-Z/MQL
Metric
DIN

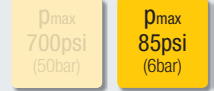
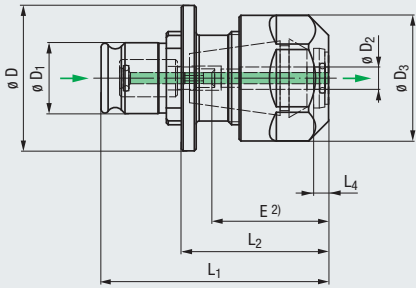
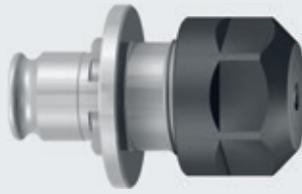

- Product Finder
- Soft-synchro
- Speed-synchro
- KSN
- MQL**
- SFM
- HF
- EM
- Accessories
- Tech. Info

new												
Type		$\varnothing D_2$	Tool Taper			$\varnothing D$	$\varnothing D_1$	$\varnothing D_3$	L_1	L_2	EDP Number	
EM 01-Z/MQL	M4.5 - M10	6 / 7 mm	Internal taper 60° 	ER 20 (GB)	Hi-Q/ERC 20	39	19	34	61	39.5	F4501001.13D6	★
	M8, M9, M11, M12	8 / 9 mm				39	19	34	61	39.5	F4501001.13D8	★
	M10	10 mm				39	19	34	61	39.5	F4501001.13D10	★
	M4.5 - M6 M8	6 mm	External taper 90° 	ER 20 (GB)	Hi-Q/ERC 20	39	19	34	61	39.5	F4501001.23D6	★
	M7, M10	7 mm				39	19	34	61	39.5	F4501001.23D7	★
	M8	8 mm				39	19	34	61	39.5	F4501001.23D8	★
	M12	9 mm				39	19	34	61	39.5	F4501001.23D9	★
	M10	10 mm				39	19	34	61	39.5	F4501001.23D10	★

1) If used with taps / roll form taps with internal coolant supply

1) Clamping depths E, see page 624 - 625

Only suitable for quick-change tap holders type KSN/MQL

Length adjustment screw as well as clamping nut for sealing disks are included in the delivery

Accessories



Collets type ER (GB)

» 610 - 613



Sealing disks type DS/ER

» 616



Clamping wrench

» 622

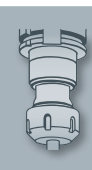

- Product Finder
- Soft-synchro
- Speed-synchro
- KSN
- MQL**
- SFM
- HF
- EM
- Accessories
- Tech. Info

EM-Z/MQL

Metric
DIN

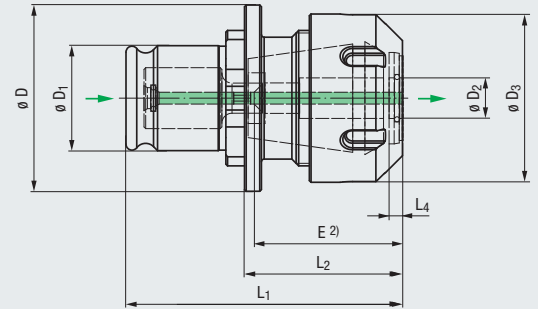
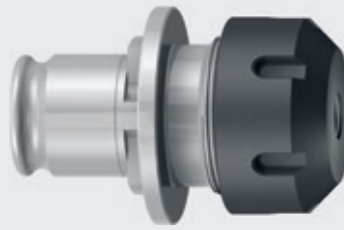

IKZ

MQL¹⁾

ρ_{max}
700psi
(50bar)

ρ_{max}
85psi
(6bar)

L+ 2 mm

~

L+

new												
Type		$\varnothing D_2$	Tool taper			mm					EDP Number	
						$\varnothing D$	$\varnothing D_1$	$\varnothing D_3$	L_1	L_2		
EM 03-Z/MQL	M10 - M16	10 - 12 mm	Internal taper 60° 	ER 32 (GB)	Hi-Q/ERC 32	55	31	50	81.5	46.5	F4503001.13D10	★
	M18 - M20	14 - 16 mm				55	31	50	81.5	46.5	F4503001.13D14	★
	M10	10 mm	External taper 90° 	ER 32 (GB)	Hi-Q/ERC 32	55	31	50	81.5	46.5	F4503001.23D10	★
	M14 - M16	11 - 12 mm				55	31	50	81.5	46.5	F4503001.23D12	★
M18	14 mm	55				31	50	81.5	46.5	F4503001.23D14	★	
M20	16 mm	55				31	50	81.5	46.5	F4503001.23D16	★	

¹⁾ If used with taps / roll form taps with internal coolant supply

¹⁾ Clamping depths E, see page 624 - 625

Only suitable for quick-change tap holders type KSN/MQL

Length adjustment screw as well as clamping nut for sealing disks are included in the delivery

Accessories

- Collets type ER (GB) ▶▶ 610 - 613
- Sealing disks type DS/ER ▶▶ 616
- Clamping wrench ▶▶ 622

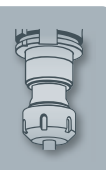

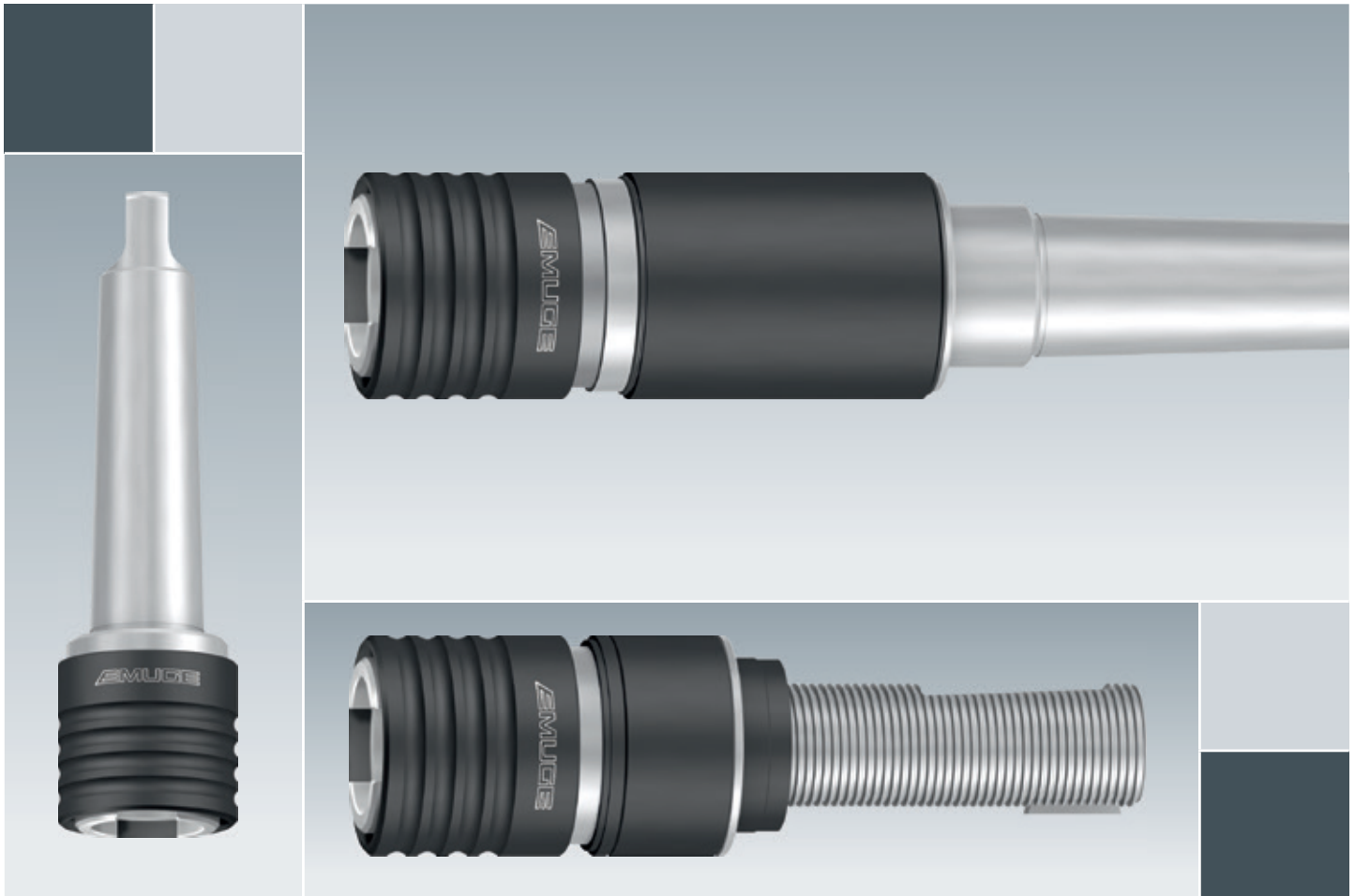

SFM Series

Application on multi-spindle machines and transfer lines

Especially suitable, too, for multi-spindle heads due to their slim design.



- Product Finder
- Soft-synchro
- Speed-synchro
- KSN
- MQL
- SFM**
- HF
- EM
- Accessories
- Tech. Info

SFM

Morse Taper Shank

DIN 228 B (ASME B5.10)

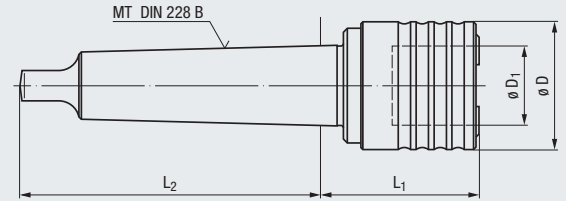
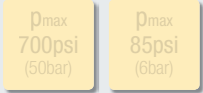

For use on multi-spindle machines and transfer lines

Type	Shank Size	mm				EDP Number			
		ø D	ø D ₁	L ₁	L ₂				
SFM 00	M1 - M10 (No.0 - 1/4)	EM 00	MT 1	23	13	39	62	F0100101	★
			MT 2	23	13	40	75	F0100102	★
SFM 01	M3 - M14 (No.0 - 9/16)	EM 01	MT 1	32	19	43	62	F0101101	★
			MT 2	32	19	44	75	F0101102	★
			MT 3	32	19	44	94	F0101103	★
SFM 03	M4.5 - M24 (1/4 - 7/8)	EM 03	MT 2	50	31	61	75	F0103102	★
			MT 3	50	31	61	94	F0103103	★
			MT 4	50	31	62	117.5	F0103104	★
SFM 04	M14 - M36 (5/8 - 1 3/8)	EM 04	MT 3	72	48	90	94	F0104103	★
			MT 4	72	48	91	117.5	F0104104	★
			MT 5	72	48	95	149.5	F0104105	★

Morse taper shank with clamping thread acc. DIN 228 A upon request

Further designs upon request

Accessories



Quick-change adapters EM series ▶▶ 583 - 601

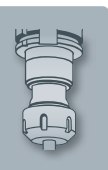

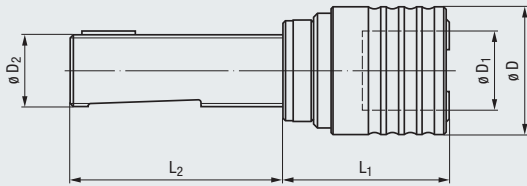
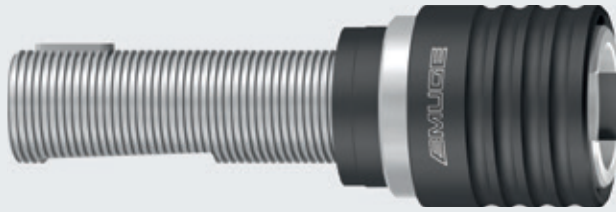

SFM

Trapezoidal Shank

DIN 6327



For use on multi-spindle machines
and transfer lines

Type	Shank Size $\varnothing D_2$	mm				EDP Number			
		$\varnothing D$	$\varnothing D_1$	L_1	L_2				
SFM 00	M1 - M10 (No.0 - 1/4)	EM 00	Tr 16 x 1.5	23	13	45	73	F0100213	★
			Tr 20 x 2	23	13	45	76	F0100214	
SFM 01	M3 - M14 (No.0 - 9/16)	EM 01	Tr 16 x 1.5	32	19	49	73	F0101213	★
			Tr 20 x 2	32	19	49	76	F0101214	★
			Tr 28 x 2	32	19	49	83	F0101216	★
SFM 03	M4.5 - M24 (1/4 - 7/8)	EM 03	Tr 20 x 2	50	31	66	76	F0103214	★
			Tr 28 x 2	50	31	66	83	F0103216	★
			Tr 36 x 2	50	31	68	104	F0103218	★
SFM 04	M14 - M36 (5/8 - 1 3/8)	EM 04	Tr 28 x 2	72	48	95	83	F0104216	
			Tr 36 x 2	72	48	97	104	F0104218	★
			Tr 48 x 2	72	48	101	126	F0104219	

Further designs upon request

Accessories



Quick-change adapters EM series

►► 583 - 601



SFM

ACME Shank

ASME B5.11

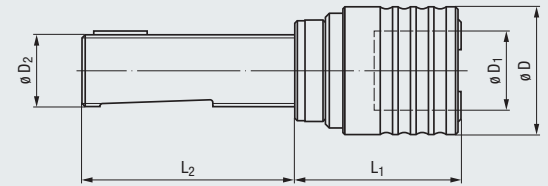
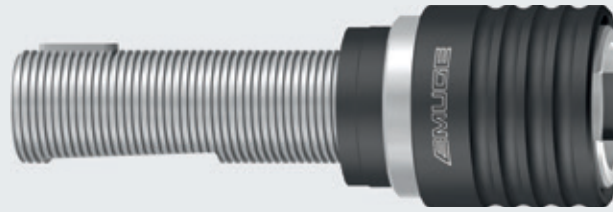

For use on multi-spindle machines and transfer lines

Type	Shank Size ϕD_2 ACME	inch				EDP Number			
		ϕD	ϕD_1	L_1	L_2				
SFM 00	M1 - M10 (No.0 - 1/4)	EM 00	5/8 x 16 3/4 x 12	0.9055 0.9055	0.5118 0.5118	1.7126 1.7126	2.5787 2.5787	F0100271 F0100272	★ ★
	SFM 01	M3 - M14 (No.0 - 9/16)	EM 01	5/8 x 16	1.2598	0.7480	1.8701	2.5787	F0101271
3/4 x 12				1.2598	0.7480	1.8701	2.5787	F0101272	★
1 1/16 x 12				1.2598	0.7480	1.8307	3.2087	F0101275	★
SFM 03	M4.5 - M24 (1/4 - 7/8)	EM 03	1 1/16 x 12	1.9685	1.2205	2.5394	3.2087	F0103275	★
			1 3/8 x 12	1.9685	1.2205	2.4213	4.2126	F0103276	★
SFM 04	M14 - M36 (5/8 - 1 3/8)	EM 04	1 3/8 x 12	2.8346	1.8898	3.6811	4.2126	F0104276	★
			1 7/8 x 12	2.8346	1.8898	3.6811	5.2165	F0104277	★

Further designs upon request

Accessories



Quick-change adapters EM series ▶▶ 583 - 601



SFM-NP

Trapezoidal Shank

DIN 6327

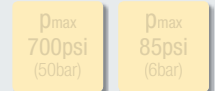
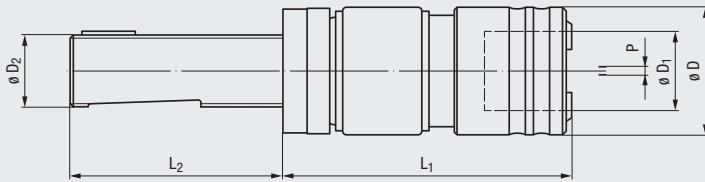
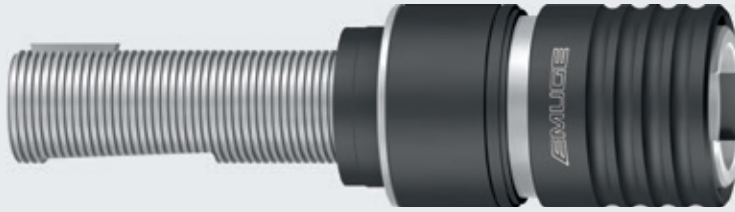

For use on multi-spindle machines and transfer lines

Type			Shank Size $\varnothing D_2$	$\varnothing D$	$\varnothing D_1$	mm L_1	L_2	P	EDP Number	
SFM 00-NP	M1 - M10 (No.0 - 1/4)	EM 00	Tr 16 x 1.5	23	13	65	73	0.8	F2110213	upon request
			Tr 20 x 2	23	13	65	76	0.8	F2110214	
SFM 01-NP	M3 - M14 (No.0 - 9/16)	EM 01	Tr 16 x 1.5	32	19	70	73	1.4	F2111213	upon request
			Tr 20 x 2	32	19	70	76	1.4	F2111214	
			Tr 28 x 2	32	19	70	83	1.4	F2111216	
SFM 03-NP	M4.5 - M24 (1/4 - 7/8)	EM 03	Tr 20 x 2	50	31	96	76	2.5	F2113214	upon request
			Tr 28 x 2	50	31	96	83	2.5	F2113216	
			Tr 36 x 2	50	31	98	104	2.5	F2113218	

Further designs upon request

Accessories



Quick-change adapters EM series ▶▶ 583 - 601



SFM-NP

ACME Shank

ASME B5.11

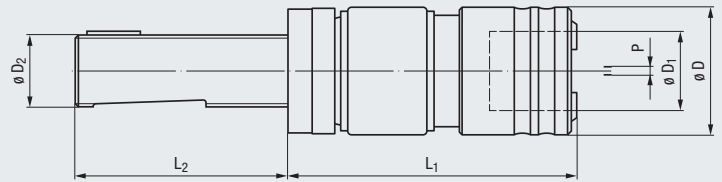
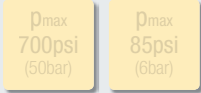
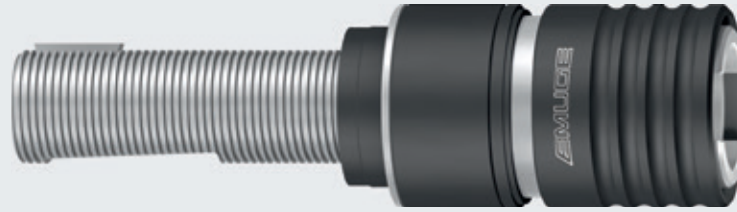

For use on multi-spindle machines and transfer lines

Type			Shank Size $\varnothing D_2$ ACME	$\varnothing D$	$\varnothing D_1$	inch		P	EDP Number	
						L_1	L_2			
SFM 00-NP	M1 - M10 (No.0 - 1/4)	EM 00	5/8 x 16	0.9055	0.5118	2.5000	2.5787	0.0315	F2110M33	upon request
			3/4 x 12	0.9055	0.5118	2.5000	2.5787	0.0315	F2110M34	
SFM 01-NP	M3 - M14 (No.0 - 9/16)	EM 01	3/4 x 12	1.2598	0.7480	2.6969	2.5787	0.0551	F2111M34	upon request
			1 1/16 x 12	1.2598	0.7480	2.6969	3.2087	0.0551	F2111M37	
SFM 03-NP	M4.5 - M24 (1/4 - 7/8)	EM 03	1 1/16 x 12	1.9685	1.2205	3.7205	3.2087	0.0984	F2113M37	upon request
			1 3/8 x 12	1.9685	1.2205	3.7205	4.2126	0.0984	F2113M39	

Further designs upon request

Accessories



Quick-change adapters EM series ▶▶ 583 - 601

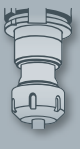

SFM-L-DZ

Morse Taper Shank

DIN 228 B (ASME B5.10)

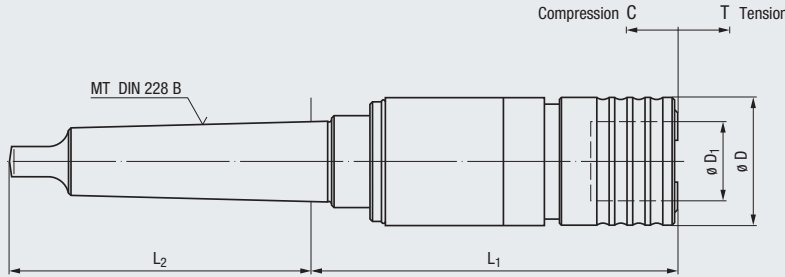
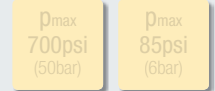
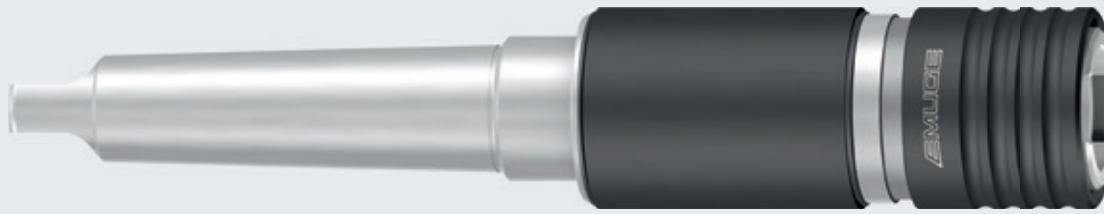

For use on multi-spindle machines and transfer lines

Type	Shank Size	mm								EDP Number	
		ø D	ø D ₁	L ₁	L ₂	C	T				
SFM 00-L20-DZ	M1 - M10 (No.0 - 1/4)	EM 00	MT 1	23	13	90	62	10	10	F0180101.7	★
			MT 2	23	13	91	75	10	10	F0180102.7	★
SFM 00-L30-DZ	M1 - M10 (No.0 - 1/4)	EM 00	MT 1	23	13	105	62	15	15	F0190101.7	★
			MT 2	23	13	106	75	15	15	F0190102.7	★
SFM 01-L20-DZ	M3 - M14 (No.0 - 9/16)	EM 01	MT 1	32	19	102	62	10	10	F0181101.7	★
			MT 2	32	19	103	75	10	10	F0181102.7	★
			MT 3	32	19	103	94	10	10	F0181103.7	★
SFM 01-L30-DZ	M3 - M14 (No.0 - 9/16)	EM 01	MT 1	32	19	117	62	15	15	F0191101.7	★
			MT 2	32	19	118	75	15	15	F0191102.7	★
			MT 3	32	19	118	94	15	15	F0191103.7	★
SFM 01-L40-DZ	M3 - M14 (No.0 - 9/16)	EM 01	MT 1	32	19	132	62	20	20	F0201101.7	★
			MT 2	32	19	133	75	20	20	F0201102.7	★
			MT 3	32	19	133	94	20	20	F0201103.7	★
SFM 03-L30-DZ	M4.5 - M24 (1/4 - 7/8)	EM 03	MT 2	50	31	142	75	15	15	F0183102.7	★
			MT 3	50	31	142	94	15	15	F0183103.7	★
SFM 03-L40-DZ	M4.5 - M24 (1/4 - 7/8)	EM 03	MT 4	50	31	143	117.5	15	15	F0183104.7	★
			MT 2	50	31	157	75	20	20	F0193102.7	★
			MT 3	50	31	157	94	20	20	F0193103.7	★
SFM 04-L30-DZ	M14 - M36 (5/8 - 1 3/8)	EM 04	MT 4	50	31	158	117.5	20	20	F0193104.7	★
			MT 3	72	48	188	94	15	15	F0184103.7	★
SFM 04-L40-DZ	M14 - M36 (5/8 - 1 3/8)	EM 04	MT 4	72	48	189	117.5	15	15	F0184104.7	★
			MT 5	72	48	190	149.5	15	15	F0184105.7	★
SFM 04-L40-DZ	M14 - M36 (5/8 - 1 3/8)	EM 04	MT 3	72	48	203	94	20	20	F0194103.7	★
			MT 4	72	48	204	117.5	20	20	F0194104.7	★
			MT 5	72	48	205	149.5	20	20	F0194105.7	★

Morse taper shank with clamping thread acc. DIN 228 A upon request

Further designs upon request

Accessories



Quick-change adapters EM series ▶ 583 - 601



SFM-L-DZ

Trapezoidal Shank

DIN 6327

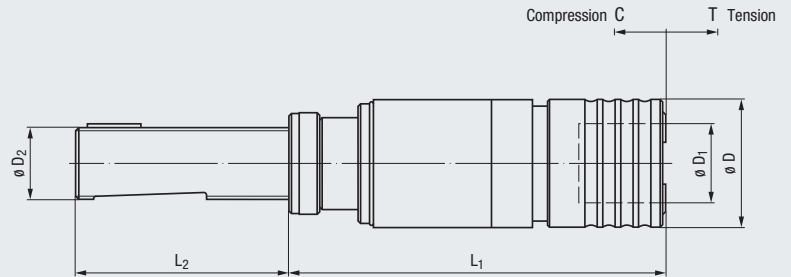
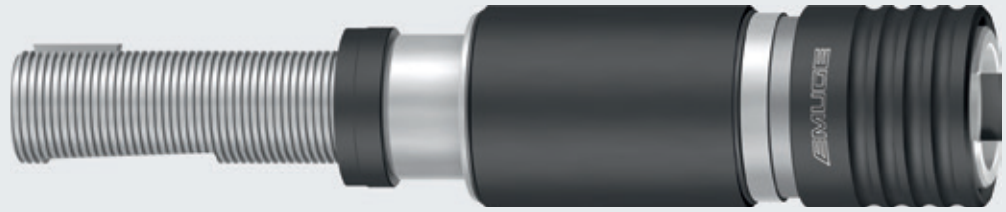

For use on multi-spindle machines and transfer lines

Type	Shank Size $\varnothing D_2$	EM	mm							EDP Number	★
			$\varnothing D$	$\varnothing D_1$	L_1	L_2	C	T			
SFM 00-L20-DZ	M1 - M10 (No.0 - 1/4)	EM 00	Tr 16 x 1.5	23	13	96	73	10	10	F0180213.7	★
			Tr 20 x 2	23	13	96	76	10	10	F0180214.7	★
SFM 00-L30-DZ	M1 - M10 (No.0 - 1/4)	EM 00	Tr 16 x 1.5	23	13	111	73	15	15	F0190213.7	★
			Tr 20 x 2	23	13	111	76	15	15	F0190214.7	★
SFM 01-L20-DZ	M3 - M14 (No.0 - 9/16)	EM 01	Tr 16 x 1.5	32	19	108	73	10	10	F0181213.7	★
			Tr 20 x 2	32	19	108	76	10	10	F0181214.7	★
			Tr 28 x 2	32	19	108	83	10	10	F0181216.7	★
SFM 01-L30-DZ	M3 - M14 (No.0 - 9/16)	EM 01	Tr 16 x 1.5	32	19	123	73	15	15	F0191213.7	★
			Tr 20 x 2	32	19	123	76	15	15	F0191214.7	★
			Tr 28 x 2	32	19	123	83	15	15	F0191216.7	★
SFM 01-L40-DZ	M3 - M14 (No.0 - 9/16)	EM 01	Tr 16 x 1.5	32	19	138	73	20	20	F0201213.7	★
			Tr 20 x 2	32	19	138	76	20	20	F0201214.7	★
			Tr 28 x 2	32	19	138	83	20	20	F0201216.7	★
SFM 03-L30-DZ	M4.5 - M24 (1/4 - 7/8)	EM 03	Tr 20 x 2	50	31	147	76	15	15	F0183214.7	★
			Tr 28 x 2	50	31	147	83	15	15	F0183216.7	★
SFM 03-L40-DZ	M4.5 - M24 (1/4 - 7/8)	EM 03	Tr 36 x 2	50	31	149	104	15	15	F0183218.7	★
			Tr 20 x 2	50	31	162	76	20	20	F0193214.7	★
			Tr 28 x 2	50	31	162	83	20	20	F0193216.7	★
SFM 04-L30-DZ	M14 - M36 (5/8 - 1 3/8)	EM 04	Tr 36 x 2	50	31	164	104	20	20	F0193218.7	★
			Tr 28 x 2	72	48	193	83	15	15	F0184216.7	★
SFM 04-L40-DZ	M14 - M36 (5/8 - 1 3/8)	EM 04	Tr 36 x 2	72	48	195	104	15	15	F0184218.7	★
			Tr 48 x 2	72	48	199	126	15	15	F0184219.7	★
			Tr 28 x 2	72	48	208	83	20	20	F0194216.7	★
SFM 04-L40-DZ	M14 - M36 (5/8 - 1 3/8)	EM 04	Tr 36 x 2	72	48	210	104	20	20	F0194218.7	★
			Tr 48 x 2	72	48	214	126	20	20	F0194219.7	★

Further designs upon request

Accessories



Quick-change adapters EM series ▶ 583 - 601



SFM-L-DZ

ACME Shank

ASME B5.11

- Product Finder
- Soft-synchro
- Speed-synchro
- KSN
- MQL
- SFM
- HF
- EM
- Accessories
- Tech. Info

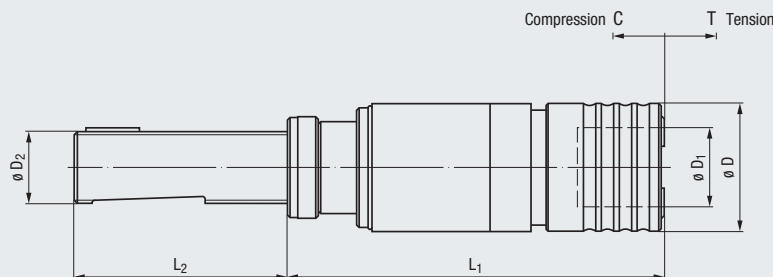
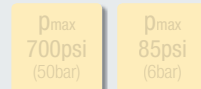
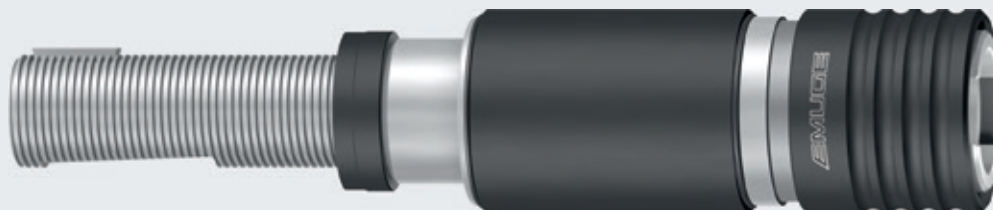

For use on multi-spindle machines and transfer lines

Type	Image 1	Image 2	Shank Size ø D ₂ ACME	inch						EDP Number	★
				ø D	ø D ₁	L ₁	L ₂	C	T		
SFM 00-L20-DZ	M1 - M10 (No.0 - 1/4)	EM 00	5/8 x 16	0.9055	0.5118	3.7205	2.5787	0.3937	0.3937	F0180271.7	★
			3/4 x 12	0.9055	0.5118	3.7205	2.5787	0.3937	0.3937	F0180272.7	★
SFM 00-L30-DZ	M1 - M10 (No.0 - 1/4)	EM 00	5/8 x 16	0.9055	0.5118	4.3110	2.5787	0.5906	0.5906	F0190271.7	★
			3/4 x 12	0.9055	0.5118	4.3110	2.5787	0.5906	0.5906	F0190272.7	★
SFM 01-L20-DZ	M3 - M14 (No.0 - 9/16)	EM 01	5/8 x 16	1.2598	0.7480	4.1929	2.5787	0.3937	0.3937	F0181271.7	★
			3/4 x 12	1.2598	0.7480	4.1929	2.5787	0.3937	0.3937	F0181272.7	★
SFM 01-L30-DZ	M3 - M14 (No.0 - 9/16)	EM 01	1 1/16 x 12	1.2598	0.7480	4.1929	3.2087	0.3937	0.3937	F0181275.7	★
			5/8 x 16	1.2598	0.7480	4.7835	2.5787	0.5906	0.5906	F0191271.7	★
			3/4 x 12	1.2598	0.7480	4.7835	2.5787	0.5906	0.5906	F0191272.7	★
SFM 03-L30-DZ	M4.5 - M24 (1/4 - 7/8)	EM 03	1 1/16 x 12	1.9685	1.2205	5.7283	3.2087	0.5906	0.5906	F0183275.7	★
			3/4 x 12	1.9685	1.2205	5.7283	2.5787	0.5906	0.5906	F0183272.7	★
			1 3/8 x 12	1.9685	1.2205	5.7283	4.2126	0.5906	0.5906	F0183276.7	★
SFM 03-L40-DZ	M4.5 - M24 (1/4 - 7/8)	EM 03	3/4 x 12	1.9685	1.2205	6.3189	2.5787	0.7874	0.7874	F0193272.7	★
			1 1/16 x 12	1.9685	1.2205	6.3189	3.2087	0.7874	0.7874	F0193275.7	★
			1 3/8 x 12	1.9685	1.2205	6.3189	4.2126	0.7874	0.7874	F0193276.7	★
SFM 04-L30-DZ	M14 - M36 (5/8 - 1 3/8)	EM 04	1 1/16 x 12	2.8346	1.8898	7.5394	3.2087	0.5906	0.5906	F0184275.7	★
			1 3/8 x 12	2.8346	1.8898	7.5394	4.2126	0.5906	0.5906	F0184276.7	★
SFM 04-L40-DZ	M14 - M36 (5/8 - 1 3/8)	EM 04	1 7/8 x 12	2.8346	1.8898	7.5394	5.2165	0.5906	0.5906	F0184277.7	★
			1 1/16 x 12	2.8346	1.8898	8.1299	3.2087	0.7874	0.7874	F0194275.7	★
			1 3/8 x 12	2.8346	1.8898	8.1299	4.2126	0.7874	0.7874	F0194276.7	★
			1 7/8 x 12	2.8346	1.8898	8.1299	5.2165	0.7874	0.7874	F0194277.7	★

Further designs upon request

Accessories



Quick-change adapters EM series ▶ 583 - 601



- Product Finder
- Soft-synchro
- Speed-synchro
- KSN
- MQL
- SFM
- HF
- EM
- Accessories
- Tech. Info

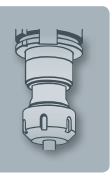

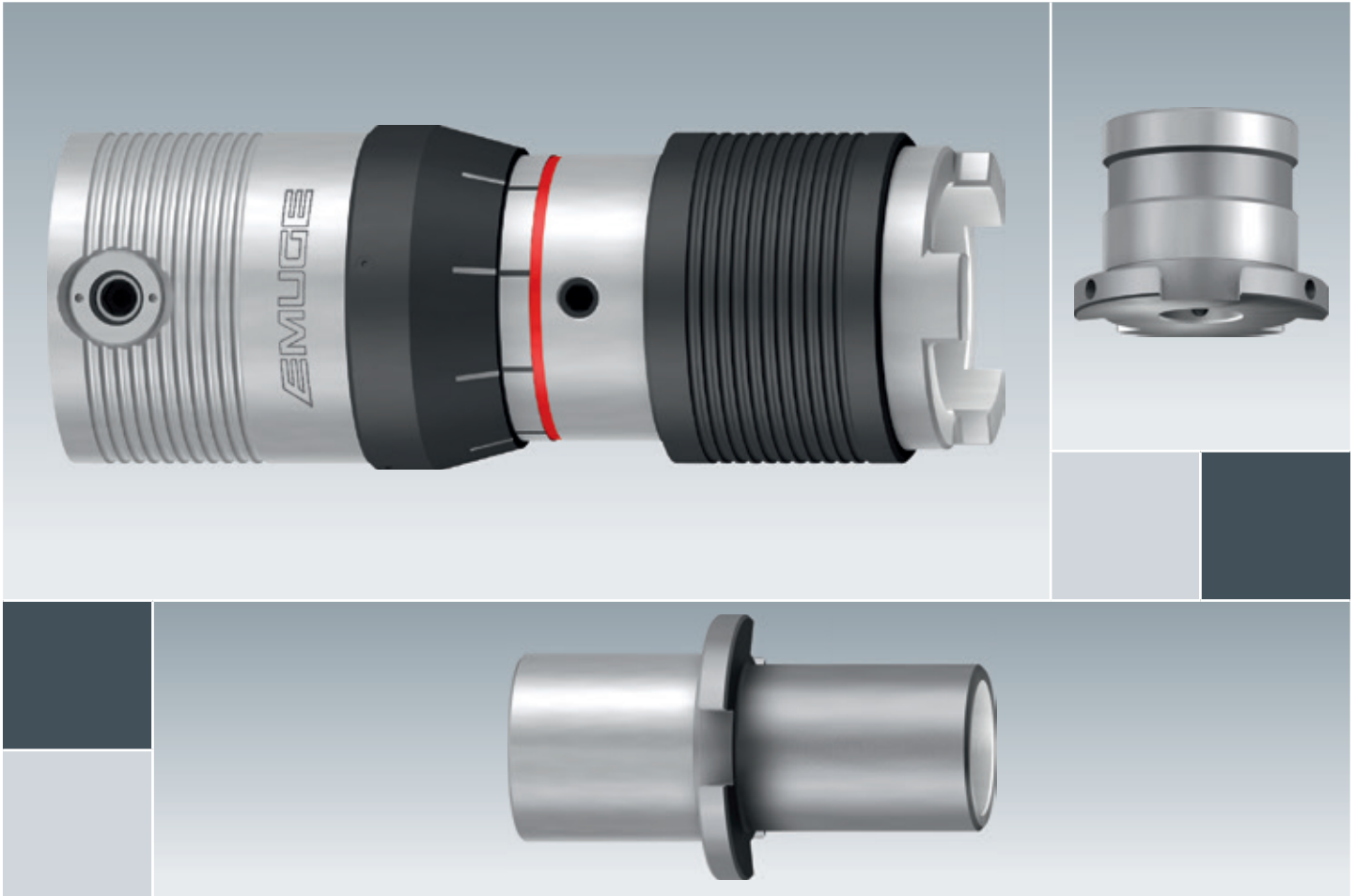

HF Series

Application on CNC machining centers and boring mills

For the production of big threads up to M160. Depending on the type: equipped with safety functions just like adjustable overload clutch and large length compensation.



- Product Finder
- Soft-synchro
- Speed-synchro
- KSN
- MQL
- SFM
- HF**
- EM
- Accessories
- Tech. Info

HF

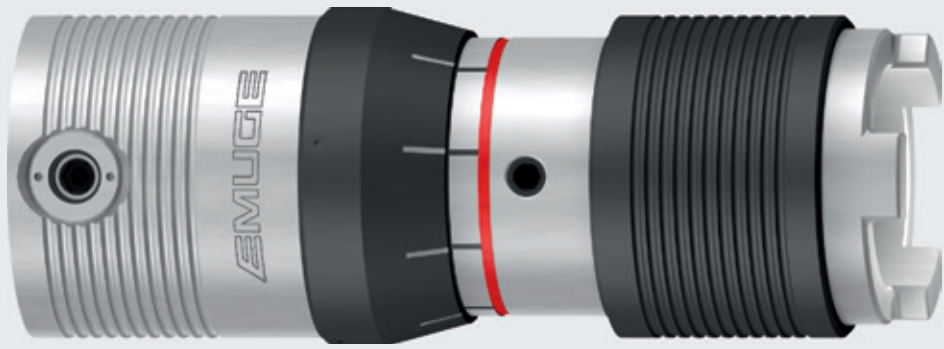

ρ_{max}
700psi
(50bar)

ρ_{max}
85psi
(6bar)

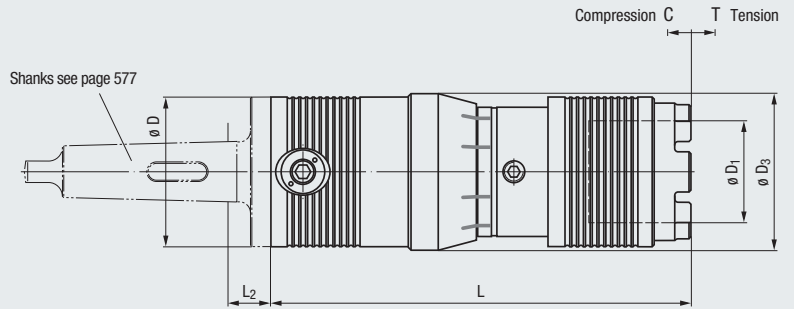

For use on CNC machining centers, other machine tools and pillar drilling machines

Type	Tap	Adapter	Maximum Permissible Torque	inch						Weight (lbs)	EDP Number	★
				θD	θD_1	θD_3	L	C	T			
HF 20	M24 - M76 (1 - 2 1/2)	HE 2	958 ft lbs (1300 Nm)	4.3307	2.9528	4.5276	12.1260	0.5906	0.5906	32.56	F0332999	★
HF 30	M36 - M160 (1 3/8 - 3 1/2)	HE 3	2213 ft lbs (3000 Nm)	6.2992	3.5433	6.2992	14.6457	0.7874	0.7874	80.30	F0333999	★

Available with internal coolant supply up to 145 psi (10 bar) upon request

Accessories

Quick-change adapters type HE

» » 578 - 581

Shanks type HF

» » 577

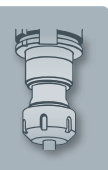

For Type	Shank Size	inch L ₂	Weight (lbs)	EDP Number	
HF 20	CAT 50	2.6142	8.38	F033207.02	★
HF 30	CAT 50	2.0079	12.79	F033307.01	★

Available with internal coolant supply up to 145 psi (10 bar) upon request

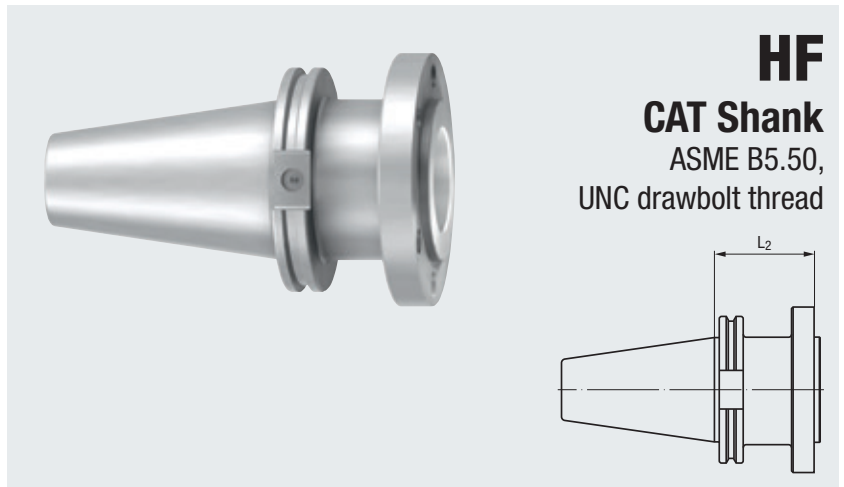

HF
CAT Shank
ASME B5.50,
UNC drawbolt thread

- Product Finder
- Soft-synchro
- Speed-synchro
- KSN
- MQL
- SFM
- HF**
- EM
- Accessories
- Tech. Info

For Type	Shank Size	mm L ₂	Weight (lbs)	EDP Number	
HF 20	SK 50	66	8.38	F033206.02	★
HF 30	SK 50	51	12.79	F033306.01	★

Available with internal coolant supply up to 145 psi (10 bar) upon request

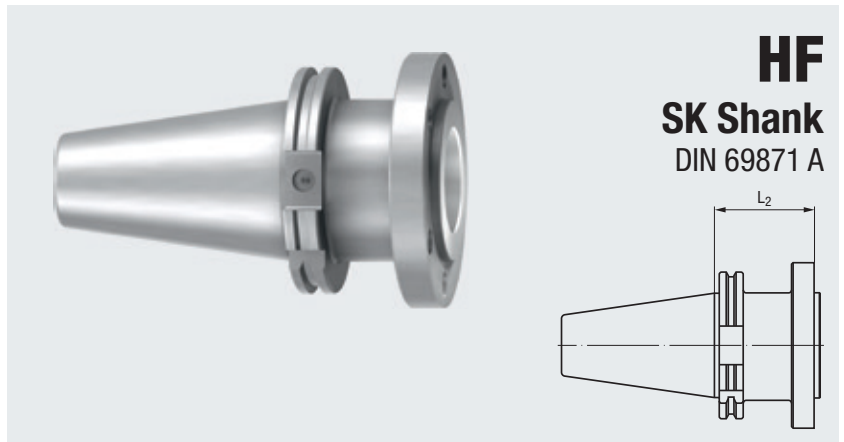

HF
SK Shank
DIN 69871 A

For Type	Shank Size	inch L ₂	Weight (lbs)	EDP Number	
HF 20	SK 40	0.8661	3.74	F033205.12	★
	SK 50	0.7087	6.60	F033205.11	★
HF 30	SK 50	0.7480	9.46	F033305.03	★
	SK 60	0.7480	22.22	F033305.04	★

Available with internal coolant supply up to 145 psi (10 bar) upon request

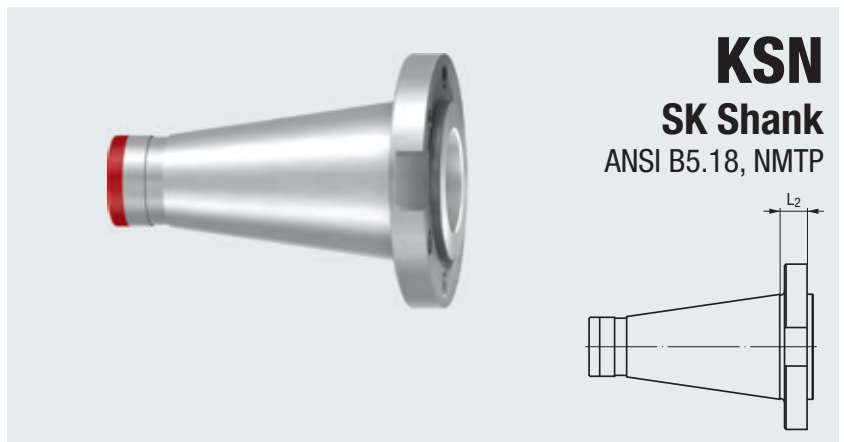

KSN
SK Shank
ANSI B5.18, NMTF

For Type	Shank Size	inch L ₂	Weight (lbs)	EDP Number	
HF 20	MT 4	1.3386	3.74	F033201.04	★
	MT 5	1.2598	6.16	F033201.05	★
	MT 6	1.2205	10.56	F033201.06	★
HF 30	MT 5	1.1811	8.58	F033301.01	★
	MT 6	1.2598	13.64	F033301.02	★

1) The "Keeper key slot" shown here is to DIN 228 B specifications and is different than ANSI B5.10 and ANSI B5.40. The taper shank will fit into Morse Taper Shank spindles, however the "Keeper key slot" is dimensionally different from the American Standard. "Keeper key slot" to ANSI B5.10 or ANSI B5.40 standards are available on a special order basis.



KSN
Morse Taper Shank
DIN 228 B (ASME B5.10)

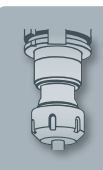

For taps/roll form taps

HE 2/IKZZ



p_{max}
700psi
(50bar)

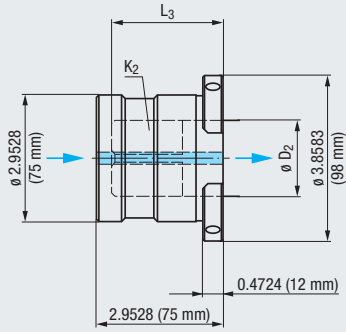

- Product Finder
- Soft-synchro
- Speed-synchro
- KSN
- MQL
- SFM
- HF
- EM
- Accessories
- Tech. Info

ASME

inch			inch		Weight (lbs)	EDP Number	
ϕD_2	K_2		L_3				
0.800	0.600	1	2.0866	4.62	F0632325.6	★	
0.896	0.672	1 1/8	2.0866	4.62	F0632326.6	★	
0.9063	0.679	3/4 NPT	1.6929	4.62	F0632355.6	★	
1.021	0.766	1 1/4	2.0866	4.62	F0632327.6	★	
1.108	0.831	1 3/8	2.0866	4.62	F0632328.6	★	
1.125	0.843	1 NPT	1.6929	4.40	F0632356.6	★	
1.233	0.925	1 1/2	2.0866	4.40	F0632329.6	★	
1.305	0.979	1 5/8	2.0866	4.40	F0632330.6	★	
1.3125	0.984	1 1/4 NPT	1.8504	4.40	F0632357.6	★	
1.430	1.072	1 3/4	2.5984	4.18	F0632331.6	★	
1.500	1.125	1 1/2 NPT	2.5984	4.18	F0632358.6	★	
1.519	1.139	1 7/8	2.5984	3.96	F0632332.6	★	
1.644	1.233	2	2.5984	3.96	F0632333.6	★	
1.769	1.327	2 1/8	2.5984	3.74	F0632334.6	★	
1.875	1.406	2 NPT	2.0866	3.74	F0632359.6	★	
1.894	1.420	2 1/4	2.5984	3.52	F0632335.6	★	
2.019	1.514	2 3/8	2.5984	3.52	F0632336.6	★	
2.100	1.575	2 1/2 - 3 ¹⁾	2.5984	3.30	F0632337.6	★	
2.225	1.669	2 5/8 ¹⁾	2.5984	2.86	F0632338.6	★	
2.250	1.687	2 1/2 NPT	2.0866	2.86	F0632360.6	★	

1) Fine threads

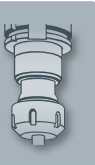

For taps/roll form taps

HE 2/IKZZ

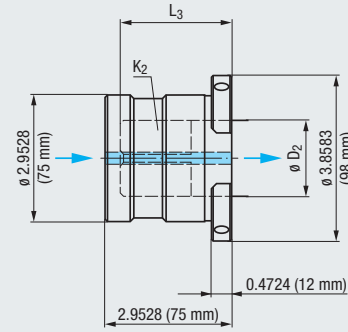

- Product Finder
- Soft-synchro
- Speed-synchro
- KSN
- MQL
- SFM
- HF**
- EM
- Accessories
- Tech. Info

DIN			mm	Weight (lbs)	EDP Number	
ø D ₂	K ₂					
18	14.5	M24	53	4.85	F0632115.6	★
20	16	M27	53	4.85	F0632116.6	★
22	18	M30	53	4.63	F0632117.6	★
25	20	M33	53	4.63	F0632118.6	★
28	22	M36	53	4.63	F0632119.6	★
32	24	M39 - M42	53	4.41	F0632120.6	★
36	29	M45 - M48	66	4.19	F0632121.6	★
40	32	M52 - M56	66	3.97	F0632122.6	★
45	35	M60	66	3.75	F0632123.6	★
50	39	M64 - M76 / M80 ¹⁾ - M90 ¹⁾	66	3.53	F0632124.6	★
56	44	M92 ¹⁾ - M120 ¹⁾	66	3.09	F0632125.6	★

1) Fine threads

For drilling and countersinking

HE 2

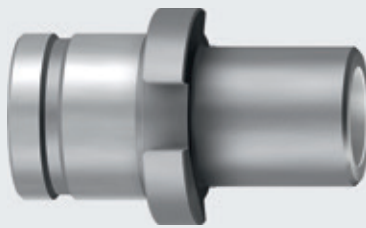

Internal taper acc. DIN 228 B

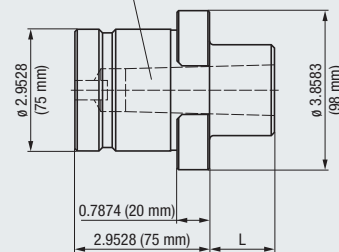

Internal Taper	inch	Weight (lbs)	EDP Number	
MT	L			
MT 3	0.9843	7.05	F0642803	★
MT 4	1.8898	7.28	F0642804	★
MT 5	3.1496	7.50	F0642805	★

● = In stock
★ = Allow 7 days for delivery

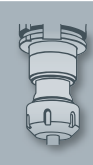

For taps/roll form taps

HE 3

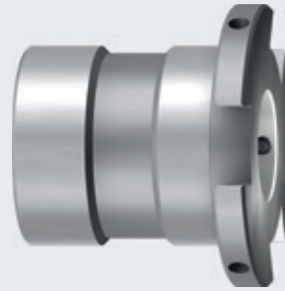
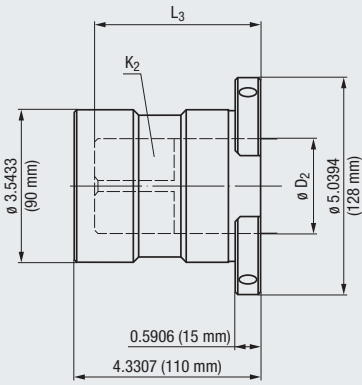

- Product Finder
- Soft-synchro
- Speed-synchro
- KSN
- MQL
- SFM
- HF
- EM
- Accessories
- Tech. Info

ASME

inch			inch		Weight (lbs)	EDP Number	
ϕD_2	K_2		L_3				
1.108	0.831	1 3/8	2.9921	9.68	F0633328	★	
1.125	0.843	1 NPT	1.4567	9.68	F0633356	★	
1.233	0.925	1 1/2	2.9921	9.46	F0633329	★	
1.305	0.979	1 5/8	2.9921	9.46	F0633330	★	
1.3125	0.984	1 1/4 NPT	1.5748	9.46	F0633357	★	
1.430	1.072	1 3/4	2.9921	9.24	F0633331	★	
1.500	1.125	1 1/2 NPT	1.7717	9.02	F0633358	★	
1.519	1.139	1 7/8	2.9921	9.02	F0633332	★	
1.644	1.233	2	2.9921	8.80	F0633333	★	
1.769	1.327	2 1/8	2.9921	8.58	F0633334	★	
1.875	1.406	2 NPT	1.9685	8.36	F0633359	★	
1.894	1.420	2 1/4	2.9921	8.36	F0633335	★	
2.019	1.514	2 3/8	2.9921	8.14	F0633336	★	
2.100	1.575	2 1/2 - 3	2.9921	7.92	F0633337	★	
2.225	1.669	2 5/8	3.6220	7.48	F0633338	★	
2.250	1.687	2 1/2 NPT	2.1654	7.48	F0633360	★	
2.350	1.762	2 3/4	3.6220	7.04	F0633339	★	
2.475	1.856	2 7/8	3.6220	6.60	F0633340	★	
2.543	1.907	3	3.6220	6.38	F0633341	★	
2.625	1.968	3 NPT	2.5591	6.16	F0633361	★	
2.668	2.001	3 1/8	3.6220	6.16	F0633342	★	
2.793	2.095	3 1/4	3.6220	7.02	F0633343	★	
2.8125	2.108	3 1/2 NPT	2.9921	5.72	F0633362	★	

Available with internal coolant supply up to 145 psi (10 bar) upon request

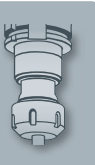

For taps/roll form taps

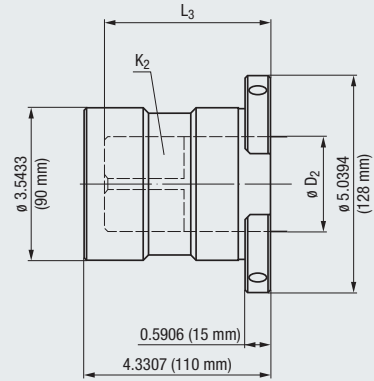
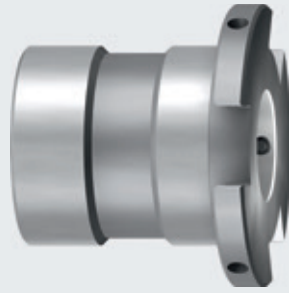

HE 3



- Product Finder
- Soft-synchro
- Speed-synchro
- KSN
- MQL
- SFM
- HF**
- EM
- Accessories
- Tech. Info

DIN			mm	Weight (lbs)	EDP Number	
ø D ₂	K ₂					
28	22	M36	76	9.70	F0633119	★
32	24	M39 - M42	76	9.48	F0633120	★
36	29	M45 - M48	76	9.26	F0633121	★
40	32	M52 - M56	76	8.82	F0633122	★
45	35	M60	76	8.60	F0633123	★
50	39	M64 - M90	76	8.16	F0633124	★
56	44	M92 - M120	98	7.50	F0633125	★
63	49	M122 - M150	98	6.61	F0633126	★
70	55	M155 - M160	98	5.95	F0633127	★

Available with internal coolant supply up to 145 psi (10 bar) upon request

For drilling and countersinking

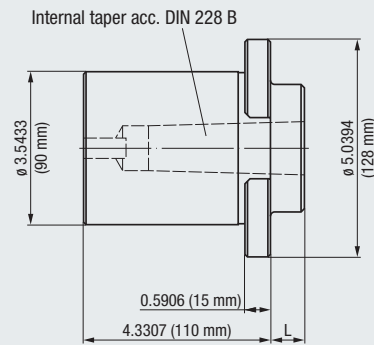
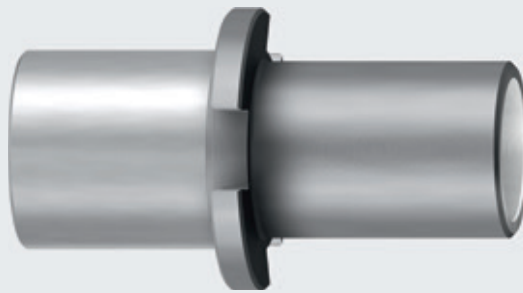

HE 3



Internal Taper	inch	Weight (lbs)	EDP Number	
MT	L			
MT 3	0.7874	13.01	F0643804	★
MT 4	1.9685	13.23	F0643805	★
MT 5	4.5276	12.79	F0643806	★

● = In stock
★ = Allow 7 days for delivery

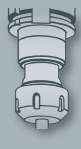

- Product Finder
- Soft-synchro
- Speed-synchro
- KSN
- MQL
- SFM
- HF
- EM
- Accessories
- Tech. Info

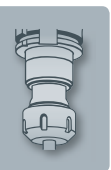



EM Series

Suitable for all our quick-change tap holders of KSN and SFM series

Depending on the type: with coolant supply through the tool center or along the shank, overload clutch and length adjustment. Clamping of the tool is achieved – depending on the type – by a ball clamping system, collets type ER (GB) or collets type PGR (GB).



- Product Finder
- Soft-synchro
- Speed-synchro
- KSN
- MQL
- SFM
- HF
- EM**
- Accessories
- Tech. Info



Page

EM	586	587	■				■	
EM-E	588	588	■				■	
EM/IKZ	589	590	■					■
EM-U	591	592	■			■	■	
EM-U-E	593	593	■			■	■	
EM-U/IKZ	594	595	■			■		■
EM-Z/ER/IKZ	596	596		■			■	■
EM-L/ER/IKZ	597	597		■		■	■	■
EM/PGR/IKZ	598				■		■	
EM-R	599	599						
EM-S	600						■	
EM-LS	601					■	■	

Description of the symbols for performance characteristics ►► 632 - 635

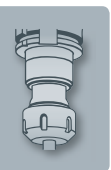

Recommended Range of Application

									
Blind hole threads	Through hole threads								
		Coarse thread							
			Fine thread						
				Clamping of solid carbide tools					
					For thermic shrinking of carbide tools with H6 shank tolerance				
						High-speed machining			
							High coolant pressure		
								For use on multi-spindle machines and transfer lines	

	■	■								EM
	■		■							EM-E
	■	■								EM/IKZ
■		■								EM-U
■			■							EM-U-E
■		■								EM-U/IKZ
	■	■		■		■	■			EM-Z/ER/IKZ
	■	■		■		■	■	■		EM-L/ER/IKZ
	■	■		■		■	■			EM/PGR/IKZ
■	■	■								EM-R
					■					EM-L
					■					EM-L-E

- Product Finder
- Soft-synchro
- Speed-synchro
- KSN
- MQL
- SFM
- HF
- EM**
- Accessories
- Tech. Info

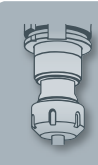

- Product Finder
- Soft-synchro
- Speed-synchro
- KSN
- MQL
- SFM
- HF
- EM**
- Accessories
- Tech. Info

EM Metric DIN

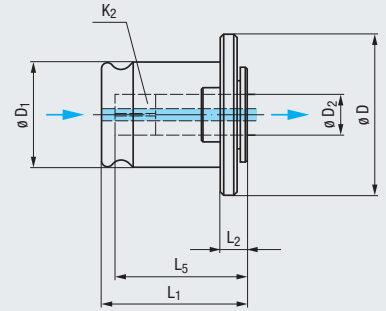
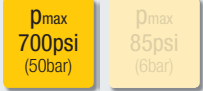

Type	EM 00/DIN	EM 01/DIN	EM 03/DIN	EM 04/DIN	EM 05/DIN	
	M1 - M10	M3 - M14	M4.5 - M24	M14 - M36	M22 - M48	
Quick-Change Adapter Dimensions (mm)	$\varnothing D$	23	30	48	70	92
	$\varnothing D_1$	13	19	31	48	60
	L_1	27	29	45	67	111
	L_2	7	7	10	11	48

DIN		mm		EDP Number		EDP Number		EDP Number		EDP Number		EDP Number			
$\varnothing D_2$	K_2				L_5		L_5		L_5		L_5		L_5		
2.5	2.1	M1 - M1.8	M3.5	F0560100	20	●									
2.8	2.1	M2 - M2.6	M4	F0560101	20	●									
3.5	2.7	M3	M4.5 - M5	F0560102	21	●	F0561102	23	●						
4	3	M3.5	M5.5	F0560103	21	●	F0561103	23	●						
4.5	3.4	M4	M6	F0560104	21	●	F0561104	23	●						
6	4.9	M4.5 - M6	M8	F0560106	23	●	F0561106	25	●	F0563106	37	●			
7	5.5	M7	M9 - M10	F0560107	23	●	F0561107	25	●	F0563107	37	●			
8	6.2	M8	M11	2)			F0561108	26	●	F0563108	38	●			
9	7	M9	M12				F0561109	27	●	F0563109	39	●			
10	8	M10					F0561110	27	●	F0563110	40	●			
11	9		M14				F0561111	27	●	F0563111	41	●	F0564111	53	●
12	9		M16				2)			F0563112	41	●	F0564112	53	●
14	11		M18							F0563113	43	●	F0564113	55	●
16	12		M20							F0563114	44	●	F0564114	56	●
18	14.5		M22 - M24							F0563115	44	●	F0564115	58	●
20	16		M27							2)			F0564116	60	●
22	18		M30							2)			F0564117	62	●
25	20		M33										F0564118	64	●
28	22		M36										F0564119	66	●
32	24		M39 - M42							2)			F0565120	104	●
36	29		M45 - M48							2)			F0565121	109	●
40	32		M52 - M56										2)		
45	35		M68										2)		

1) If used with taps / roll form taps with internal coolant supply
 2) Quick-change adapters with extended clamping range type EM-E, see page 588

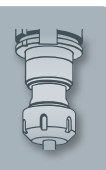

EM
Inch
ASME

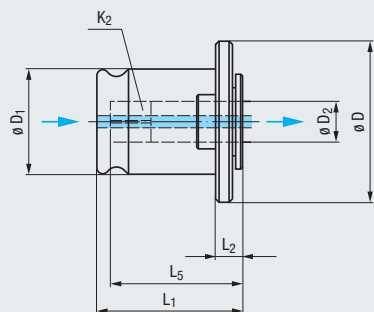

- Product Finder
- Soft-synchro
- Speed-synchro
- KSN
- MQL
- SFM
- HF
- EM**
- Accessories
- Tech. Info

Type	EM 00/ASME	EM 01/ASME	EM 03/ASME	EM 04/ASME	EM 05/ASME
	No.0 - 1/4	No.0 - 9/16	1/4 - 7/8	5/8 - 1 3/8	7/8 - 1 7/8
Quick-Change Adapter Dimensions (inch)					
ϕD	0.91	1.18	1.89	2.76	3.62
ϕD_1	0.512	0.748	1.220	1.890	2.362
L_1	1.06	1.14	1.77	2.60	4.09
L_2	0.28	0.28	0.39	0.43	1.61

ASME		inch		EDP Number		EDP Number		EDP Number		EDP Number		EDP Number	
ϕD_2	K_2				L_5		L_5		L_5		L_5		L_5
0.141	0.110	No.0 - No.6		F0560300	0.787	●	F0561300	0.866	●				
0.168	0.131	No.8		F0560301	0.846	●	F0561301	0.945	●				
0.194	0.152	No.10		F0560302	0.846	●	F0561302	0.945	●				
0.220	0.165	No.12		F0560303	0.886	●	F0561303	0.965	●				
0.255	0.191	1/4		F0560304	0.925	●	F0561304	1.004	●	F0563304	1.339	●	
0.3125	0.234	1/16 NPT					F0561350	1.063	●	F0563350	1.181	●	
0.318	0.238	5/16					F0561306	1.063	●	F0563306	1.398	●	
0.381	0.286	3/8					F0561311	1.122	●	F0563311	1.457	●	
0.323	0.242		7/16				F0561307	1.102	●	F0563307	1.437	●	
0.367	0.275		1/2				F0561310	1.122	●	F0563310	1.457	●	
0.429	0.322		9/16				F0561313	1.102	●	F0563313	1.535	●	
0.4375	0.328	1/8 NPT					F0561351	1.063	●	F0563351	1.181	●	
0.480	0.360		5/8				2)			F0563315	1.594	●	F0564315 1.673 ●
0.542	0.406		11/16							F0563317	1.654	●	F0564317 1.732 ●
0.5625	0.421	1/4 NPT								F0563352	1.161	●	F0564352 1.240 ●
0.590	0.442		3/4							F0563319	1.713	●	F0564319 1.791 ●
0.652	0.489		13/16							F0563321	1.713	●	F0564321 1.791 ●
0.6875	0.515		1/2 NPT							F0563353	1.417	●	F0564353 1.496 ●
0.697	0.523		7/8							F0563323	1.772	●	F0564323 1.850 ●
0.700	0.531	3/8 NPT								F0563354	1.299	●	F0564354 1.378 ●
0.800	0.600		1				2)			F0564325	2.382	●	F0565325 2.461 ●
0.896	0.672		1 1/8				2)			F0564326	2.441	●	F0565326 2.520 ●
0.9063	0.679		3/4 NPT							F0564355	1.634	●	F0565355 1.673 ●
1.021	0.766		1 1/4							F0564327	2.579	●	F0565327 2.657 ●
1.108	0.831		1 3/8							F0564328	2.638	●	F0565328 2.717 ●
1.125	0.843		1 NPT							F0564356	1.752	●	F0565356 1.791 ●
1.233	0.925		1 1/2							2)			F0565329 2.776 ●
1.305	0.979		1 5/8										F0565330 2.776 ●
1.430	1.072		1 3/4										F0565331 2.913 ●
1.519	1.139		1 7/8										F0565332 2.913 ●
1.644	1.233		2										2)

1) If used with taps / roll form taps with internal coolant supply
 2) Quick-change adapters with extended clamping range type EM-E, see page 588

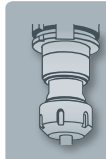

For the cutting of fine threads **MF**

EM-E Metric / Inch DIN / ASME

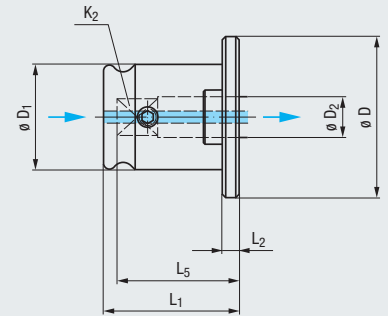

- Product Finder
- Soft-synchro
- Speed-synchro
- KSN
- MQL
- SFM
- HF
- EM
- Accessories
- Tech. Info

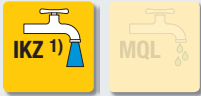

Type		EM 00-E/DIN	EM 01-E/DIN	EM 03-E/DIN	EM 04-E/DIN	EM 05-E/DIN
Fine thread MF		M8 - M11	M16	M27 - M30	M39 - M48	M52 - M60
Quick-Change Adapter Dimensions (mm)	$\varnothing D$	23	30	48	70	92
	$\varnothing D_1$	13	19	31	48	60
	L_1	23.5	25.5	40	61.5	84
	L_2	7	4	5	6	21

DIN		mm		EDP Number		EDP Number		EDP Number		EDP Number		EDP Number	
$\varnothing D_2$	K_2				L_5		L_5		L_5		L_5		L_5
8	6.2	M8	M11	F0800108	21	•							
12	9		M16				F0801112	25	•				
20	16		M27				F0803116	39	•				
22	18		M30				F0803117	39	•				
32	24		M39 - M42							F0804120	61	•	
36	29		M45 - M48							F0804121	60	•	
40	32		M52 - M56									F0805122	83
45	35		M60									F0805123	83

Type		EM 01-E/ASME	EM 03-E/ASME	EM 04-E/ASME	EM 05-E/ASME
Fine thread		5/8	1 - 1 1/8	1 1/2	2
Quick-Change Adapter Dimensions (inch)	$\varnothing D$	1.18	1.89	2.76	3.62
	$\varnothing D_1$	0.748	1.220	1.890	2.362
	L_1	1.00	1.57	2.42	3.78
	L_2	0.16	0.20	0.24	1.30

ASME		inch		EDP Number		EDP Number		EDP Number		EDP Number	
$\varnothing D_2$	K_2				L_5		L_5		L_5		L_5
0.480	0.360		5/8	F0801315	1.004	•					
0.800	0.600		1				F0803325	1.516	•		
0.896	0.672		1 1/8				F0803326	1.535	•		
1.233	0.925		1 1/2						F0804329	2.244	•
1.644	1.233		2							F0805333	3.346

1) If used with taps / roll form taps with internal coolant supply

For taps / roll form taps
without internal coolant supply

EM/IKZ
Metric
DIN

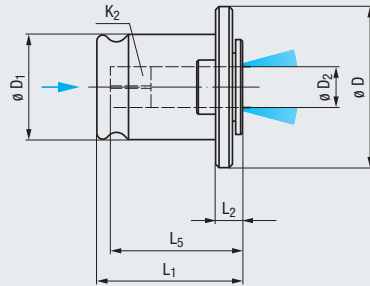

Along the tool shank

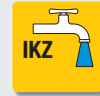

- Product Finder
- Soft-synchro
- Speed-synchro
- KSN
- MQL
- SFM
- HF
- EM**
- Accessories
- Tech. Info

Type	EM 01/IKZ/DIN	EM 03/IKZ/DIN	EM 04/IKZ/DIN	EM 05/IKZ/DIN
	M3 - M14	M4.5 - M24	M14 - M36	M22 - M48
Quick-Change Adapter Dimensions (mm)				
$\varnothing D$	30	48	70	92
$\varnothing D_1$	19	31	48	60
L_1	29	45	67	111
L_2	7	10	11	48

DIN		mm		EDP Number		EDP Number		EDP Number		EDP Number	
$\varnothing D_2$	K_2				L_5		L_5		L_5		L_5
2.5	2.1	M1 - M1.8	M3.5								
2.8	2.1	M2 - M2.6	M4								
3.5	2.7	M3	M4.5 - M5	F0561102.5	23 ●						
4	3	M3.5	M5.5	F0561103.5	23 ●						
4.5	3.4	M4	M6	F0561104.5	23 ●						
6	4.9	M4.5 - M6	M8	F0561106.5	25 ●	F0563106.5	37 ●				
7	5.5	M7	M9 - M10	F0561107.5	25 ●	F0563107.5	37 ●				
8	6.2	M8	M11	F0561108.5	26 ●	F0563108.5	38 ●				
9	7	M9	M12	F0561109.5	27 ●	F0563109.5	39 ●				
10	8	M10		F0561110.5	27 ●	F0563110.5	40 ●				
11	9		M14	F0561111.5	27 ●	F0563111.5	41 ●	F0564111.5	53 ●		
12	9		M16			F0563112.5	41 ●	F0564112.5	53 ●		
14	11		M18			F0563113.5	43 ●	F0564113.5	55 ●		
16	12		M20			F0563114.5	44 ●	F0564114.5	56 ●		
18	14.5		M22 - M24			F0563115.5	44 ●	F0564115.5	58 ●	F0565115.5	94 ●
20	16		M27					F0564116.5	60 ●	F0565116.5	96 ●
22	18		M30					F0564117.5	62 ●	F0565117.5	98 ●
25	20		M33					F0564118.5	64 ●	F0565118.5	100 ●
28	22		M36					F0564119.5	66 ●	F0565119.5	102 ●
32	24		M39 - M42							F0565120.5	104 ●
36	29		M45 - M48							F0565121.5	109 ●

● = In stock
★ = Allow 7 days for delivery



For taps / roll form taps
without internal coolant supply

EM/IKZ

Inch
ASME

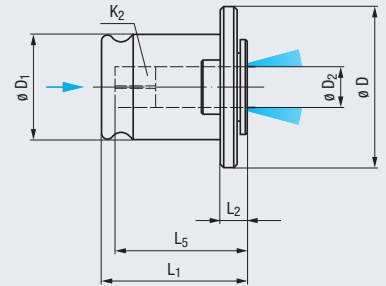
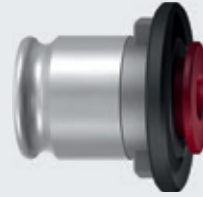

Along the tool shank

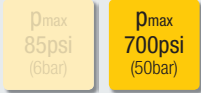

Type	EM01/IKZ/ASME	EM03/IKZ/ASME	EM04/IKZ/ASME	EM05/IKZ/ASME
	No.0 - 9/16	1/4 - 7/8	5/8 - 1 3/8	7/8 - 1 7/8
Quick-Change Adapter Dimensions (inch)				
$\varnothing D$	1.18	1.89	2.76	3.62
$\varnothing D_1$	0.748	1.220	1.890	2.362
L_1	1.14	1.77	2.60	4.09
L_2	0.28	0.39	0.43	1.61

ASME		inch				EDP Number		EDP Number		EDP Number		EDP Number		
$\varnothing D_2$	K_2						L_5		L_5		L_5		L_5	
0.141	0.110	No.0 - No.6				F0561300.5	0.866	●						
0.168	0.131	No.8				F0561301.5	0.945	●						
0.194	0.152	No.10				F0561302.5	0.945	●						
0.220	0.165	No.12				F0561303.5	0.965	●						
0.255	0.191	1/4				F0561304.5	1.004	●	F0563304.5	1.339	●			
0.3125	0.234	1/16 NPT				F0561350.5	1.063	●	F0563350.5	1.181	●			
0.318	0.238	5/16				F0561306.5	1.063	●	F0563306.5	1.398	●			
0.381	0.286	3/8				F0561311.5	1.122	●	F0563311.5	1.457	●			
0.323	0.242		7/16			F0561307.5	1.102	●	F0563307.5	1.437	●			
0.367	0.275		1/2			F0561310.5	1.122	●	F0563310.5	1.457	●			
0.429	0.322		9/16			F0561313.5	1.102	●	F0563313.5	1.535	●			
0.4375	0.328	1/8 NPT				F0561351.5	1.063	●	F0563351.5	1.181	●			
0.480	0.360		5/8						F0564315.5	1.673	●			
0.542	0.406		11/16						F0563317.5	1.654	●	F0564317.5	1.732	●
0.5625	0.421	1/4 NPT							F0563352.5	1.161	●	F0564352.5	1.240	●
0.590	0.442		3/4						F0563319.5	1.713	●	F0564319.5	1.791	●
0.652	0.489		13/16						F0563321.5	1.713	●	F0564321.5	1.791	●
0.6875	0.515		1/2 NPT						F0563353.5	1.417	●	F0564353.5	1.496	●
0.697	0.523		7/8						F0563323.5	1.772	●	F0564323.5	1.850	●
0.700	0.531	3/8 NPT							F0563354.5	1.299	●	F0564354.5	1.378	●
0.800	0.600		1						F0564325.5	2.382	●	F0565325.5	2.461	●
0.896	0.672		1 1/8						F0564326.5	2.441	●	F0565326.5	2.520	●
0.9063	0.679		3/4 NPT						F0564355.5	1.634	●	F0565355.5	1.673	●
1.021	0.766		1 1/4						F0564327.5	2.579	●	F0565327.5	2.657	●
1.108	0.831		1 3/8						F0564328.5	2.638	●	F0565328.5	2.717	●
1.125	0.843		1 NPT						F0564356.5	1.752	●	F0565356.5	1.791	●
1.233	0.925		1 1/2									F0565329.5	2.776	●
1.305	0.979		1 5/8									F0565330.5	2.776	●
1.430	1.072		1 3/4									F0565331.5	2.913	●
1.519	1.139		1 7/8									F0565332.5	2.913	●

With overload clutch

EM-U
Metric
DIN

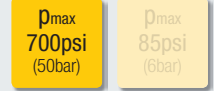
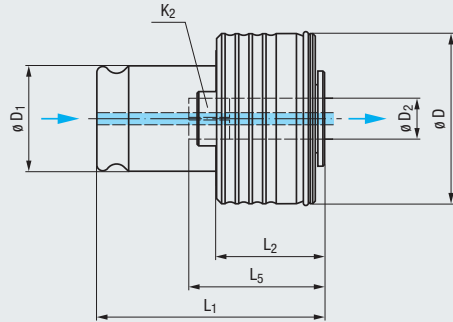

- Product Finder
- Soft-synchro
- Speed-synchro
- KSN
- MQL
- SFM
- HF
- EM**
- Accessories
- Tech. Info

Type	EM 00-U/DIN	EM 01-U/DIN	EM 03-U/DIN	EM 04-U/DIN	EM 05-U/DIN
	M1 - M10	M3 - M14	M4.5 - M24	M14 - M36	M22 - M48
Quick-Change Adapter Dimensions (mm)					
$\varnothing D$	24	33	50	72	95
$\varnothing D_1$	13	19	31	48	60
L_1	41.5	47	69	101	138
L_2	22	25	34	45	75

DIN		mm		EDP Number		EDP Number		EDP Number		EDP Number		EDP Number			
$\varnothing D_2$	K_2				L_5		L_5		L_5		L_5		L_5		
2.5	2.1	M1 - M1.8		F0570100.1	21	●									
2.5	2.1		M3.5	F0570100.2	21	●									
2.8	2.1	M2		F0570101.1	21	●									
2.8	2.1	M2.5		F0570101.2	21	●									
2.8	2.1		M4	F0570101.3	21	●									
3.5	2.7	M3		F0570102.1	22	●	F0571102.1	23	●						
3.5	2.7		M4.5 - M5	F0570102.2	22	●	F0571102.2	23	●						
4	3	M3.5		F0570103	22	●	F0571103	23	●						
4.5	3.4	M4		F0570104.1	22	●	F0571104.1	23	●						
4.5	3.4		M6	F0570104.2	22	●	F0571104.2	23	●						
6	4.9	M4.5 - M5		F0570106.1	24	●	F0571106.1	25	●	F0573106.1	38	●			
6	4.9	M6		F0570106.2	24	●	F0571106.2	25	●	F0573106.2	38	●			
6	4.9		M8	F0570106.3	24	●	F0571106.3	25	●	F0573106.3	38	●			
7	5.5		M10	F0570107	24	●	F0571107	25	●	F0573107	38	●			
8	6.2	M8		F0570107 ²⁾			F0571108	26	●	F0573108	39	●			
9	7		M12				F0571109	27	●	F0573109	40	●			
10	8	M10					F0571110	28	●	F0573110	41	●			
11	9		M14				F0571111	29	●	F0573111	42	●	F0574111	56	●
12	9		M16				F0571111 ²⁾			F0573112	42	●	F0574112	56	●
14	11		M18							F0573113	44	●	F0574113	58	●
16	12		M20							F0573114	45	●	F0574114	59	●
18	14.5		M22 - M24							F0573115	47	●	F0574115	61	●
20	16		M27							F0574116	63	●	F0575116	96	●
22	18		M30							F0574117	65	●	F0575117	98	●
25	20		M33							F0574118	67	●	F0575118	100	●
28	22		M36							F0574119	69	●	F0575119	102	●
32	24		M39 - M42							F0575120		2)	F0575120	104	●
36	29		M45 - M48							F0575121		2)	F0575121	109	●
40	32		M52 - M56											2)	
45	35		M60											2)	

1) If used with taps / roll form taps with internal coolant supply

2) Quick-change adapters with extended clamping range type EM-U-E, see page 593



With overload clutch

EM-U

Inch
ASME

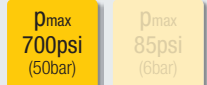
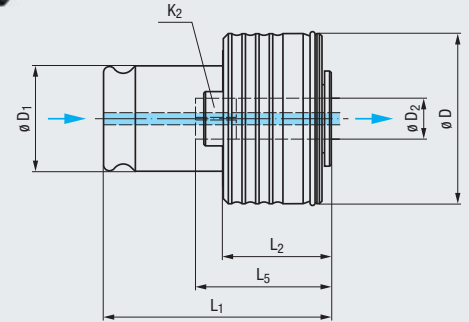

Type	EM00-U/ASME	EM01-U/ASME	EM03-U/ASME	EM04-U/ASME	EM05-U/ASME
	No.0 - 1/4	No.0 - 9/16	1/4 - 7/8	5/8 - 1 3/8	7/8 - 1 7/8
Quick-Change Adapter Dimensions (inch)					
θD	0.94	1.30	1.97	2.83	3.74
θD_1	0.512	0.748	1.220	1.890	2.362
L_1	1.63	1.85	2.72	3.98	5.16
L_2	0.87	0.98	1.34	1.77	2.68

ASME		inch		EDP Number		EDP Number		EDP Number		EDP Number		EDP Number			
θD_2	K_2				L_5		L_5		L_5		L_5		L_5		
0.141	0.110	No.0 - No.6		F0570300	0.819	●	F0571300	0.870	●						
0.168	0.131	No.8		F0570301	0.882	●	F0571301	0.933	●						
0.194	0.152	No.10		F0570302	0.882	●	F0571302	0.933	●						
0.220	0.165	No.12		F0570303	0.909	●	F0571303	0.961	●						
0.255	0.191	1/4		F0570304	0.941	●	F0571304	0.992	●	F0573304	1.280	●			
0.3125	0.234	1/16 NPT					F0571350	1.055	●	F0573350	1.055	●			
0.318	0.238	5/16					F0571306	1.055	●	F0573306	1.343	●			
0.381	0.286	3/8					F0571311	1.118	●	F0573311	1.406	●			
0.323	0.242		7/16				F0571307	1.087	●	F0573307	1.374	●			
0.367	0.275		1/2				F0571310	1.118	●	F0573310	1.406	●			
0.429	0.322		9/16				F0571313	1.181	●	F0573313	1.469	●			
0.4375	0.328	1/8 NPT					F0571351	1.055	●	F0573351	1.055	●			
0.480	0.360		5/8				2)		F0573315	1.531	●	F0574315	1.531	●	
0.542	0.406		11/16						F0573317	1.594	●	F0574317	1.594	●	
0.5625	0.421	1/4 NPT							F0573352	1.110	●	F0574352	1.110	●	
0.590	0.442		3/4						F0573319	1.657	●	F0574319	1.657	●	
0.652	0.489		13/16						F0573321	1.657	●	F0574321	1.657	●	
0.6875	0.515		1/2 NPT						F0573353	1.339	●	F0574353	1.339	●	
0.697	0.523		7/8						F0573323	1.720	●	F0574323	1.720	●	
0.700	0.531	3/8 NPT							F0573354	1.213	●	F0574354	1.213	●	
0.800	0.600		1						2)			F0574325	2.315	●	
0.896	0.672		1 1/8						2)			F0574326	2.350	●	
0.9063	0.679		3/4 NPT									F0574355	1.496	●	
1.021	0.766		1 1/4									F0574327	2.476	●	
1.108	0.831		1 3/8									F0574328	2.539	●	
1.125	0.843		1 NPT									F0574356	1.618	●	
1.233	0.925		1 1/2									2)	F0575329	2.693	●
1.305	0.979		1 5/8										F0575330	2.693	●
1.430	1.072		1 3/4										F0575331	2.819	●
1.519	1.139		1 7/8										F0575332	2.819	●
1.644	1.233		2										2)		

1) If used with taps / roll form with internal coolant supply

2) Quick-change adapters with extended clamping range type EM-U-E, see page 593

3) $L_1 = 5.00$
 $L_2 = 2.52$

For taps / roll form taps
without internal coolant supply

With overload clutch

EM-U/IKZ

Metric

DIN

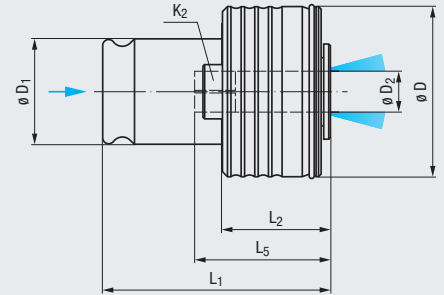

- Product Finder
- Soft-synchro
- Speed-synchro
- KSN
- MQL
- SFM
- HF
- EM
- Accessories
- Tech. Info



Along the tool shank



Type	EM 01-U/IKZ/DIN	EM 03-U/IKZ/DIN	EM 04-U/IKZ/DIN	EM 05-U/IKZ/DIN	
	M3 - M14	M4.5 - M24	M14 - M36	M22 - M48	
Quick-Change Adapter Dimensions (mm)	$\varnothing D$	33	50	72	95
	$\varnothing D_1$	19	31	48	60
	L_1	47	69	101	138
	L_2	25	34	45	75

DIN		mm		EDP Number		EDP Number		EDP Number		EDP Number					
$\varnothing D_2$	K_2				L_5		L_5		L_5		L_5				
2.5	2.1	M1 - M1.8	M3.5												
2.8	2.1	M2 - M2.5	M4												
3.5	2.7	M3		F0571102.1.5	22	●									
3.5	2.7		M4.5 - M5	F0571102.2.5	22	●									
4	3	M3.5		F0571103.5	22	●									
4.5	3.4	M4		F0571104.1.5	23	●									
4.5	3.4		M6	F0571104.2.5	23	●									
6	4.9	M4.5 - M5		F0571106.1.5	25	●	F0573106.1.5	38	●						
6	4.9	M6		F0571106.2.5	25	●	F0573106.2.5	38	●						
6	4.9		M8	F0571106.3.5	25	●	F0573106.3.5	38	●						
7	5.5		M10	F0571107.5	25	●	F0573107.5	38	●						
8	6.2	M8		F0571108.5	26	●	F0573108.5	39	●						
9	7		M12	F0571109.5	27	●	F0573109.5	40	●						
10	8	M10		F0571110.5	28	●	F0573110.5	41	●						
11	9		M14	F0571111.5	29	●	F0573111.5	42	●	F0574111.5	56	●			
12	9		M16				F0573112.5	42	●	F0574112.5	56	●			
14	11		M18				F0573113.5	44	●	F0574113.5	58	●			
16	12		M20				F0573114.5	45	●	F0574114.5	59	●			
18	14.5		M22 - M24				F0573115.5	47	●	F0574115.5	61	●	F0575115.5	94	●
20	16		M27							F0574116.5	63	●	F0575116.5	96	●
22	18		M30							F0574117.5	65	●	F0575117.5	98	●
25	20		M33							F0574118.5	67	●	F0575118.5	100	●
28	22		M36							F0574119.5	69	●	F0575119.5	102	●
32	24		M39 - M42										F0575120.5	104	●
36	29		M45 - M48										F0575121.5	109	●

For taps / roll form taps
without internal coolant supply

With overload clutch

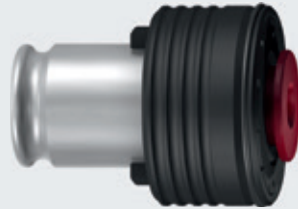

EM-U/IKZ

Inch
ASME

Along the tool shank

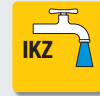

p_{max}
700psi
(50bar)

p_{max}
85psi
(6bar)

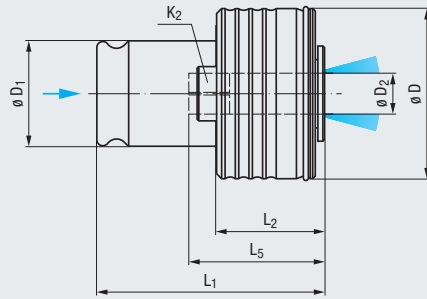
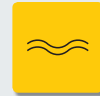

Type	EM01-U/IKZ/ASME	EM03-U/IKZ/ASME	EM04-U/IKZ/ASME	EM05-U/IKZ/ASME
	No.0 - 9/16	1/4 - 7/8	5/8 - 1 3/8	7/8 - 1 7/8

Quick-Change Adapter Dimensions (inch)	$\varnothing D$	1.30	1.97	2.83	3.74
	$\varnothing D_1$	0.748	1.220	1.890	2.362
	L_1	1.85	2.72	3.98	5.43
	L_2	0.98	1.34	1.77	2.95

ASME		inch		inch	inch	EDP Number	L_5	●	EDP Number	L_5	●	EDP Number	L_5	●	EDP Number	L_5	●	
$\varnothing D_2$	K_2																	
0.141	0.110	No.0 - No.6				F0571300.5	0.870	●										
0.168	0.131	No.8				F0571301.5	0.933	●										
0.194	0.152	No.10				F0571302.5	0.933	●										
0.220	0.165	No.12				F0571303.5	0.961	●										
0.255	0.191	1/4				F0571304.5	0.992	●	F0573304.5	1.280	●							
0.3125	0.234	1/16 NPT				F0571350.5	1.055	●	F0573350.5	1.055	●							
0.318	0.238	5/16				F0571306.5	1.055	●	F0573306.5	1.343	●							
0.381	0.286	3/8				F0571311.5	1.118	●	F0573311.5	1.406	●							
0.323	0.242			7/16		F0571307.5	1.087	●	F0573307.5	1.374	●							
0.367	0.275			1/2		F0571310.5	1.181	●	F0573310.5	1.406	●							
0.429	0.322			9/16		F0571313.5	1.181	●	F0573313.5	1.469	●							
0.4375	0.328	1/8 NPT							F0573351.5	1.055	●							
0.480	0.360			5/8					F0573315.5	1.531	●	F0574315.5	1.531	●				
0.542	0.406			11/16					F0573317.5	1.594	●	F0574317.5	1.594	●				
0.5625	0.421	1/4 NPT							F0573352.5	1.110	●	F0574352.5	1.110	●				
0.590	0.442			3/4					F0573319.5	1.657	●	F0574319.5	1.657	●				
0.652	0.489			13/16					F0573321.5	1.657	●	F0574321.5	1.657	●				
0.6875	0.515			1/2 NPT					F0573353.5	1.339	●	F0574353.5	1.339	●				
0.697	0.523			7/8					F0573323.5	1.720	●	F0574323.5	1.720	●	F0575323.5	2.319	●	
0.700	0.531	3/8 NPT							F0573354.5	1.213	●	F0574354.5	1.213	●	F0575354.5 ³⁾	1.213	●	
0.800	0.600			1					F0574325.5	2.315	●	F0575325.5	2.378	●	F0575325.5	2.378	●	
0.896	0.672			1 1/8					F0574326.5	2.350	●	F0575326.5	2.441	●	F0575326.5	2.441	●	
0.9063	0.679			3/4 NPT					F0574355.5	1.496	●	F0575355.5 ³⁾	1.496	●	F0575355.5 ³⁾	1.496	●	
1.021	0.766			1 1/4					F0574327.5	2.476	●	F0575327.5	2.567	●	F0575327.5	2.567	●	
1.108	0.831			1 3/8					F0574328.5	2.539	●	F0575328.5	2.630	●	F0575328.5	2.630	●	
1.125	0.843			1 NPT					F0574356.5	1.618	●	F0575356.5 ³⁾	1.618	●	F0575356.5 ³⁾	1.618	●	
1.233	0.925			1 1/2								F0575329.5	2.693	●	F0575329.5	2.693	●	
1.305	0.979			1 5/8								F0575330.5	2.693	●	F0575330.5	2.693	●	
1.430	1.072			1 3/4								F0575331.5	2.819	●	F0575331.5	2.819	●	
1.519	1.139			1 7/8								F0575332.5	2.819	●	F0575332.5	2.819	●	

³⁾ $L_1 = 5.00$
 $L_2 = 2.52$



With collet adaption

EM-Z/ER/IKZ

Metric / Inch

DIN / ASME

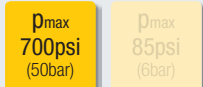
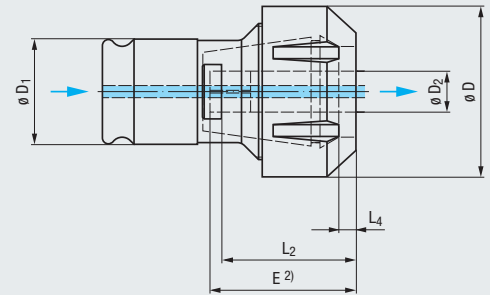
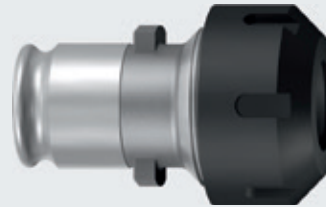

Type	Collet	$\varnothing D_2$	Collet	Clamping Nut	mm				EDP Number	
					$\varnothing D$	$\varnothing D_1$	L_2	L_4		
EM 00-Z/ ER/IKZ	M2 - M8 (No.2 - No.10)	2.5 - 7 mm 0.141 - 0.194	ER 11 (GB)	Hi-Q/ER 11	19	13	23	0.9	F0860001	●
EM 01-Z/ ER/IKZ	M4 - M12 (No.8 - 1/2)	4.5 - 10 mm 0.168 - 0.381	ER 20 (GB)	Hi-Q/ERC 20	34	19	34.5	5	F0861001.13	●
EM 03-Z/ ER/IKZ	M4 - M20 (1/4 - 3/4)	4.5 - 16 mm 0.255 - 0.590	ER 32 (GB)	Hi-Q/ERC 32	50	31	41.5	5	F0863001.13	●

1) If used with taps / roll form taps with internal coolant supply

1) Clamping depths E, see page 624 - 625

EM00-Z/ER/IKZ:

Clamping nut without integrated seal is included in the delivery

EM01-Z/ER/IKZ, EM03-Z/ER/IKZ:

Clamping nut for sealing disks is included in the delivery

Accessories

- 
Collets type ER (GB)
▶▶ 610 - 613
- 
Sealing disks type DS/ER
▶▶ 616
- 
Clamping nut with integrated seal, type Hi-Q/ERC 11
▶▶ 619
- 
Clamping wrench
▶▶ 622

With collet adaption
and length adjustment

EM-L/ER/IKZ
Metric / Inch
DIN / ASME

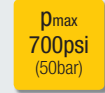
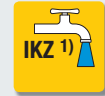
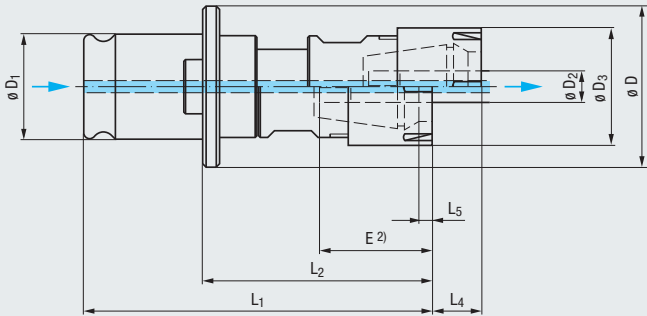
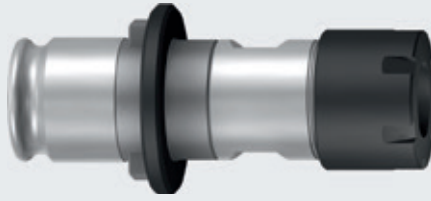

Type		$\varnothing D_2$			mm						EDP Number		
					$\varnothing D$	$\varnothing D_1$	$\varnothing D_3$	L_1	L_2	L_4			L_5
EM 00-L/ER/IKZ	M2 - M8 (No.2 - No.10)	2.5 - 7 mm 0.141 - 0.194	ER 11 (GB)	Hi-Q/ERM 11	23	13	16	57.5	38	8	0.9	F3500011	●
EM 01-L/ER/IKZ	M4 - M12 (No.8 - 1/2)	4.5 - 9 mm 0.168 - 0.381	ER 16 (GB)	Hi-Q/ERMC 16	30	19	22	72	50.5	10	5	F3501016	●
EM 03-L/ER/IKZ	M8 - M20	8 - 16 mm	ER 25 (GB)	Hi-Q/ERMC 25	48	31	35	103	68	15	5	F3503025	●

1) If used with taps / roll form taps with internal coolant supply

2) Clamping depths E, see page 624 - 625

EM00-L/ER/IKZ:

Clamping nut without integrated seal is included in the delivery

EM01-L/ER/IKZ, EM03-L/ER/IKZ:

Clamping nut for sealing disks is included in the delivery

Accessories



Collets type ER (GB)

▶▶ 610 - 613



Sealing disks type DS/ER

▶▶ 616



Clamping nut with integrated seal, type Hi-Q/ERMC 11

▶▶ 618



Set of clamping wrenches

▶▶ 622

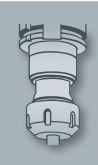

- Product Finder
- Soft-synchro
- Speed-synchro
- KSN
- MQL
- SFM
- HF
- EM**
- Accessories
- Tech. Info

EM/PGR/IKZ

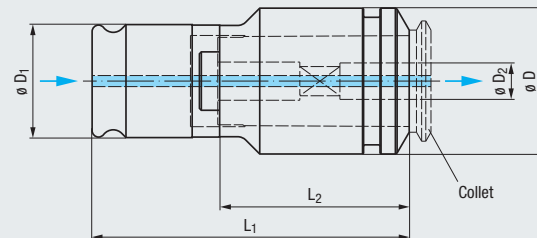
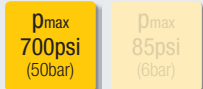
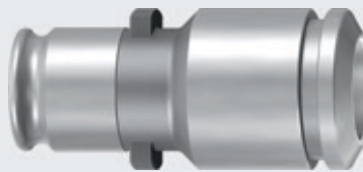

Type	Thread	$\varnothing D_2$	Collet	inch				EDP Number	★
				$\varnothing D$	$\varnothing D_1$	L_1	L_2		
EM 01/PGR/IKZ	M4 - M12 (No. 10 - 1/4)	4.5 - 10 mm	PGR 15 (GB)	0.9449	0.7480	2.5197	1.6535	F3561015	★
EM 03/PGR/IKZ	M8 - M20 (1/4 - 3/4)	8 - 16 mm	PGR 25 (GB)	1.5748	1.2205	3.4252	2.0472	F3563025	★

1) If used with taps / roll form taps with internal coolant supply

Accessories



Collets type PGR-GB

» 630

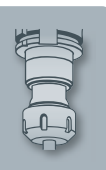



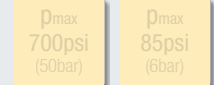

EM-R
Metric / Inch
DIN / ASME

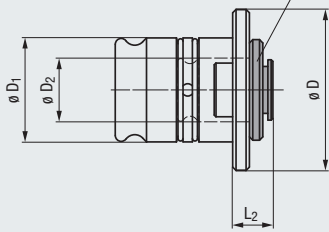

Quick-change adapter in assembled condition



- Product Finder
- Soft-synchro
- Speed-synchro
- KSN
- MQL
- SFM
- HF
- EM**
- Accessories
- Tech. Info

Type		inch				EDP Number	
		ø D	ø D ₁	ø D ₂	L ₂		
EM 01/00-R	EM 00	1.1811	0.7480	0.5118	0.4331	F0891000	★
EM 03/00-R	EM 00	1.8898	1.2205	0.5118	0.4724	F0893000	★
EM 03/01-R	EM 01	1.8898	1.2205	0.7480	0.4724	F0893001	★
EM 04/01-R	EM 01	2.7559	1.8898	0.7480	0.5118	F0894001	★
EM 04/03-R	EM 03	2.7559	1.8898	1.2205	0.6693	F0894003	★
EM 05/03-R	EM 03	3.6220	2.3622	1.2205	0.9449	F0895003	★
EM 05/04-R	EM 04	3.6220	2.3622	1.8898	1.0630	F0895004	★

● = In stock
★ = Allow 7 days for delivery

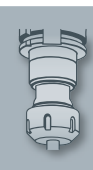

For thermic shrinking of carbide tools with h6 shank tolerance

EM-S

Metric

DIN

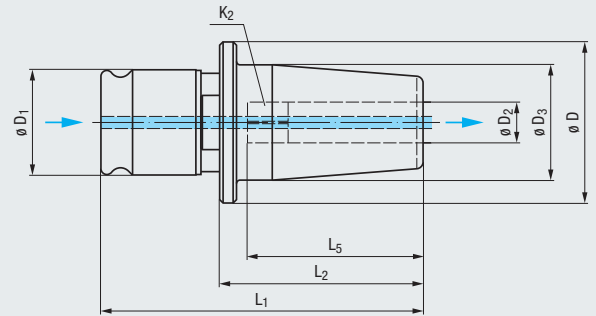
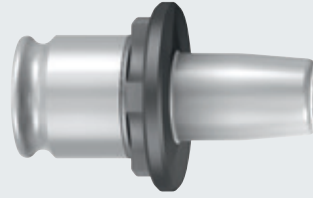

- Product Finder
- Soft-synchro
- Speed-synchro
- KSN
- MQL
- SFM
- HF
- EM**
- Accessories
- Tech. Info

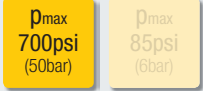

Type	EM01-S/DIN	EM03-S/DIN	
Solid carbide	M4.5 - M12	M4.5 - M20	
ϕD	30	48	
ϕD_1	19	31	
Quick-Change Adapter Dimensions (mm)			
ϕD_3	22	22	34
L_1	61.5	75	95
L_2	40	40	60

DIN															
mm				EDP Number	L_5		★	EDP Number	L_5		★	EDP Number	L_5		★
ϕD_2	K_2				min.	max.			min.	max.			min.	max.	
6	4.9	M4.5 - M6	M8	F6561106	26	31	★	F6563106	26	31	★				
7	5.5	M7	M9 - M10	F6561107	26	31	★	F6563107	26	31	★				
8	6.2	M8	M11	F6561108	27	32	★	F6563108	27	32	★				
9	7	M9	M12	F6561109	28	33	★	F6563109	28	33	★				
10	8	M10		F6561110	29	34	★	F6563110	29	34	★				
11	9		M14									F6563111	41	46	★
12	9		M16									F6563112	41	46	★
14	11		M18									F6563113	43	48	★
16	12		M20									F6563114	44	49	★

For thermic shrinking of carbide tools with h6 shank tolerance

EM-LS
Metric
DIN

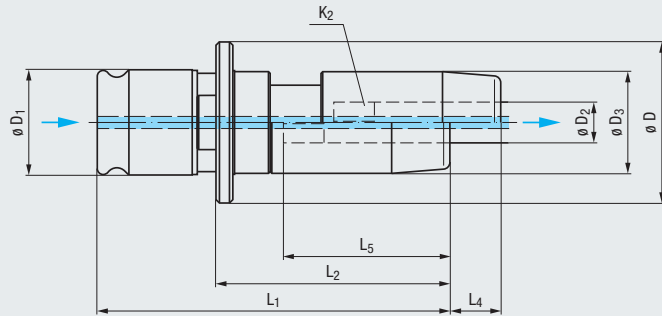
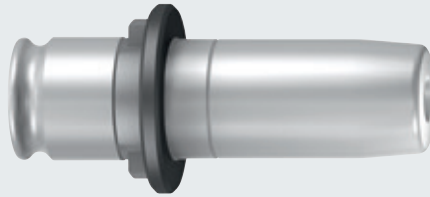

- Product Finder
- Soft-synchro
- Speed-synchro
- KSN
- MQL
- SFM
- HF
- EM**
- Accessories
- Tech. Info

Type	EM01-LS/DIN	EM03-LS/DIN		
Solid carbide	M4.5 - M12	M4.5 - M20		
Quick-Change Adapter Dimensions (mm)	ϕD	30	48	
	ϕD_1	19	31	
	ϕD_3	22	30	
	L_1	69	104	
	L_2	49	69	
	L_4	10	15	

DIN															
mm				EDP Number		L ₅									
ϕD_2	K ₂														
6	4.9	M4.5 - M6	M8	F6581106	31	★									
7	5.5	M7	M9 - M10	F6581107	31	★									
8	6.2	M8	M11	F6581108	32	★									
9	7	M9	M12	F6581109	33	★									
10	8	M10		F6581110	34	★	F6583110	34	★						
11	9		M14				F6583111	46	★						
12	9		M16				F6583112	46	★						
14	11		M18				F6583113	48	★						
16	12		M20				F6583114	49	★						

● = In stock
★ = Allow 7 days for delivery

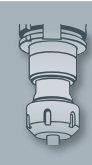

- Product Finder
- Soft-synchro
- Speed-synchro
- KSN
- MQL
- SFM
- HF
- EM
- Accessories
- Tech. Info





Accessories for Tap Holders



With Shank Adaption according to DIN 1835 B

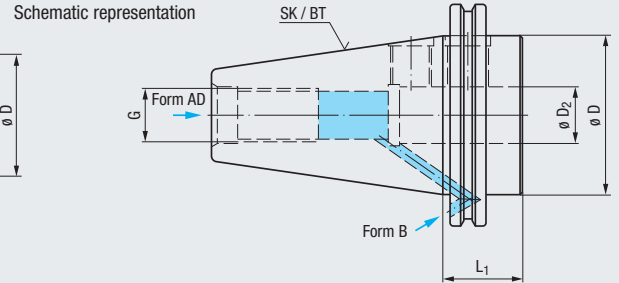
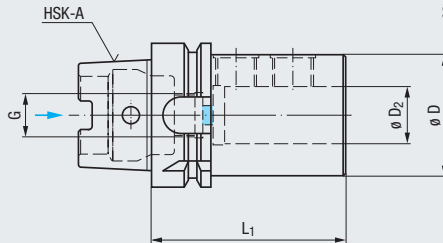
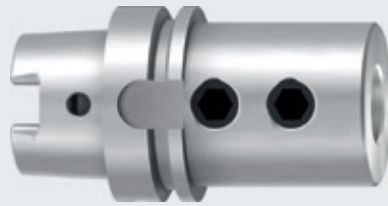

Type	Form	Shank Size	mm				EDP Number	
			$\varnothing D_2$	$\varnothing D$	G	L ₁		
DIN 69893 A 1) 2)		HSK-A40	20	52	M12 x 1	75	F33000C.02	★
		HSK-A40	25	65	M12 x 1	105	F33000C.03	★
		HSK-A50	20	52	M16 x 1	80	F33000C.04	★
		HSK-A50	25	65	M16 x 1	107	F33000C.05	★
		HSK-A50	32	77	M16 x 1	114	F33000C.06	★
		HSK-A63	25	53	M18 x 1	85	F33000C.07	★
		HSK-A63	32	72	M18 x 1	110	F33000C.08	★
		HSK-A80	25	65	M20 x 1.5	90	F33000C.09	★
		HSK-A80	32	72	M20 x 1.5	110	F33000C.10	★
		HSK-A100	25	65	M24 x 1.5	100	F33000C.11	★
HSK-A100	32	72	M24 x 1.5	96	F33000C.12	★		
DIN 69871 AD 1)	AD	SK 40	25	45	M16	35	F330006.01	★
		SK 50	25	70	M24	35	F330006.02	★
		SK 50	32	70	M24	35	F330006.05	★
DIN 69871 B 1)	B	SK 40	25	45	M16	35	F330006.03	★
		SK 50	25	70	M24	35	F330006.04	★
		SK 50	32	70	M24	35	F330006.06	★
DIN 2080	AD	SK 30	20	36	M12	34	F330005.03	★
		SK 40	25	44	M16	22	F330005.01	★
		SK 50	25	70	M24	16	F330005.02	★
		SK 50	32	70	M24	16	F330005.04	★
ASME B5.50 Metr.	AD	SK 40	25	45	M16	35	F330007.01	upon request
		SK 50	25	70	M24	35	F330007.02	upon request
		SK 50	32	70	M24	35	F330007.06	upon request
ASME B5.50 UNC	AD	SK 40	25	44.5	⁵ / ₈ - 11	35	F330007.03	●
		SK 50	25	70	1" - 8	35	F330007.04	●
		SK 50	32	70	1" - 8	35	F330007.05	●
JIS B 6339 (MAS 403 BT)	AD	BT 30	20	36	M12	35	F330008.04	★
		BT 40	25	45	M16	35	F330008.01	★
		BT 50	25	70	M24	44	F330008.02	★
		BT 50	32	70	M24	44	F330008.03	★

1) With bore for data chip according to DIN 69873

Further designs upon request

2) Coolant tubes and wrenches see page 606 - 607, please order separately

The locking screw is included in the delivery

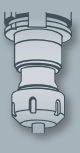

With Shank Adaption ABS®

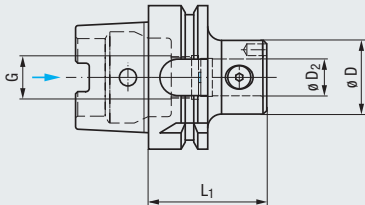
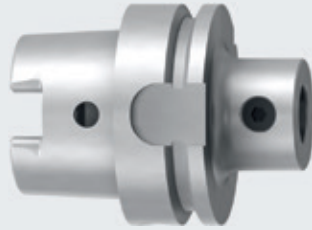

- Product Finder
- Soft-synchro
- Speed-synchro
- KSN
- MQL
- SFM
- HF
- EM
- Accessories
- Tech. Info

Type	Shank Size	mm				EDP Number	
		ø D ₂	ø D	G	L ₁		
DIN 69893 A 1)	HSK-A63	16	ABS 32	M18 x 1	50	F33000C.48	★
	HSK-A100	16	ABS 32	M24 x 1.5	60	F33000C.50	★

1) With bore for data chip according to DIN 69873

Further designs upon request

The locking screw is included in the delivery

Accessories



Coolant tubes, adapters and wrenches

» 606 - 607

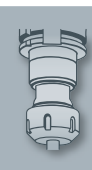

- Product Finder
- Softsynchro
- Speedsynchro
- KSN
- MQL
- SFM
- HF
- EM
- Accessories
- Tech. Info

Coolant Tubes

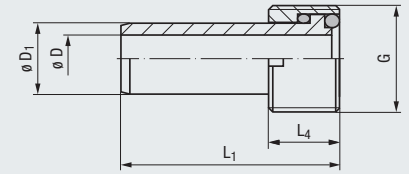

DIN 69895

For Shank Size	mm						EDP Number	★
	ø D	ø D ₁	L ₄	L ₁	G			
HSK-A40	5	8	8	29.5	M12 x 1	F330049.02	★	
HSK-A50	6.4	10	10	33	M16 x 1	F330049.03	★	
HSK-A63	8	12	12	36.5	M18 x 1	F330049.04	★	
HSK-A80	10	14	14	40	M20 x 1.5	F330049.05	★	
HSK-A100	12	16	16	44	M24 x 1.5	F330049.06	★	

Coolant Tubes

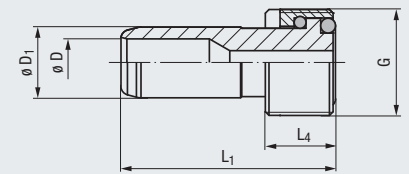

Suitable for Softsynchro® Modular/MQL and Speedsynchro® Modular/MQL

DIN 69090-4

For Shank Size	mm						EDP Number	★
	ø D	ø D ₁	L ₄	L ₁	G			
HSK-A40	5	8	8	29.5	M12 x 1	F355149.13	★	
HSK-A63	8	12	12	36.5	M18 x 1	F355149.03	★	
HSK-A100	12	16	16	44	M24 x 1.5	F355149.06	★	

Coolant Tubes

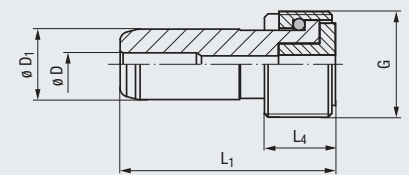

Suitable for Softsynchro® Modular/MQL and Speedsynchro® Modular/MQL

DIN 69090-4

For Design	For Shank Size	mm					EDP Number	★
		ø D	ø D ₁	L ₄	L ₁	G		
Softsynchro® 1 Modular/MQL Speedsynchro® Modular/MQL	HSK-A40	4	8	8	29.5	M12 x 1	F355149.11	★
	HSK-A63	4	12	12	36.5	M18 x 1	F355149.04	★
	HSK-A100	4	16	16	44	M24 x 1.5	F355149.08	★
Softsynchro® 3 Modular/MQL	HSK-A63	4	12	12	36.5	M18 x 1	F355349.02	★
	HSK-A100	4	16	16	44	M24 x 1.5	F355349.04	★

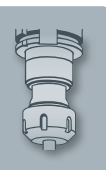

Adapters 1)

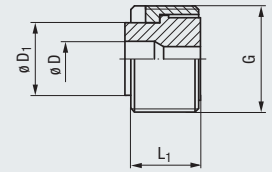

Suitable for Softsynchro® Modular/MQL and Speedsynchro® Modular/MQL

DIN 69090-4

new		mm				EDP Number	
For Shank Size	$\varnothing D$	$\varnothing D_1$	L_1	G			
HSK-A40	4	8.4	8.3	M12 x 1	F355335.01	★	
HSK-A63	6	12.4	12.3	M18 x 1	F355135.01	★	
HSK-A100	10	16.4	16.4	M24 x 1.5	F355135.02	★	

1) Adapters are used for HSK-A shanks, that means outside contour acc. DIN 69893 A, inside contour acc. DIN 69893 C

Assembly wrenches

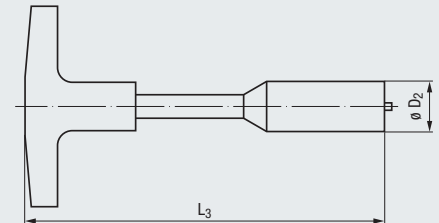

For Shank Size	$\varnothing D_2$	L_3	EDP Number	
HSK-A40	11	111	F330099.02	★
HSK-A50	15	120	F330099.03	★
HSK-A63	17	122	F330099.04	★
HSK-A80	18.5	126	F330099.05	★
HSK-A100	22	141	F330099.06	★

Use of coolant tubes with hollow taper shanks according to DIN 69893 A

The coolant tube is necessary for connecting the internal coolant supply of the machine spindle with the hollow taper shank of the tap holder.

Please note: We recommend screwing the coolant tube into the hollow taper shank even when tap holders without internal coolant supply are used (e.g. type KSN); this will help to prevent damage to the hollow taper shank clamping system in case of unintentional switching on of the internal coolant supply.

Assembly of the coolant tube in the hollow taper (HSK) shank

1. Put assembly wrench on the coolant tube.

Important: Watch the position of the pins against the grooves!

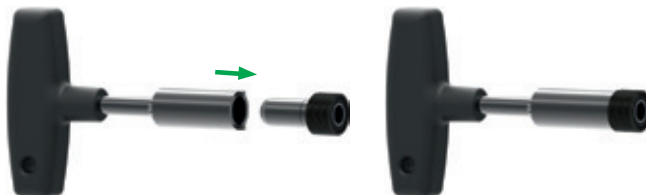

2. Screw coolant tube into the shank.





- Product Finder
- Softsynchro
- Speedsynchro
- KSN
- MQL
- SFM
- HF
- EM
- Accessories
- Tech. Info

Adjustable from both sides, for tool shanks with female center 60°





Suitable for Softsynchro® Modular/IKZ and Softsynchro® Modular/MQL

new			mm		EDP Number	
For Design	Tool Taper		ø D ₁			
Softsynchro® 1 Modular/IKZ Softsynchro® 1 Modular/MQL	Internal taper 60° 	M4.5 - M10	6 / 7		F355188.01	★
		M8, M9, M11, M12	8 / 9		F355188.02	★
		M10	10		F355188.03	★
Softsynchro® 3 Modular/IKZ Softsynchro® 3 Modular/MQL		M12	9		F355388.01	★
		M10 - M16	10 - 12		F355388.02	★
		M18 - M20	14 - 16		F355388.03	★

Adjustable from both sides, for tool shanks with male center 90°



Suitable for Softsynchro® Modular/MQL

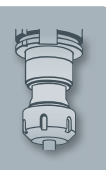

new			mm		EDP Number	
For Design	Tool Taper		ø D ₁			
Softsynchro® 1 Modular/MQL	External taper 90° 	M4.5 - M6, M8	6		F355188.04	★
		M7, M10	7		F355188.05	★
		M8	8		F355188.06	★
		M12	9		F355188.07	★
		M10	10		F355188.08	★
Softsynchro® 3 Modular/MQL		M12	9		F355388.04	★
		M10	10		F355388.05	★
		M14 - M16	11 - 12		F355388.06	★
		M18	14		F355388.07	★
		M20	16		F355388.08	★



For tool shanks with female center 60°





Suitable for Speedsynchro® Modular/IKZ and Speedsynchro® Modular/MQL

new			mm		EDP Number	
For Design	Tool Taper		∅ D ₁			
Speedsynchro® Modular/IKZ Speedsynchro® Modular/MQL	Internal taper 60° 	M4.5 - M10	6 / 7		F375188.01	★
		M8	8		F375188.02	★

For tool shanks with male center 90°



Suitable for Speedsynchro® Modular/MQL

new			mm		EDP Number	
For Design	Tool Taper		∅ D ₁			
Speedsynchro® Modular/MQL	External taper 90° 	M4.5 - M6, M8	6		F375188.03	★
		M7	7		F375188.04	★
		M8	8		F375188.05	★

- Product Finder
- Soft-synchro
- Speed-synchro
- KSN
- MQL
- SFM
- HF
- EM
- Accessories
- Tech. Info

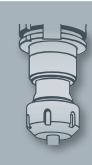

● = In stock
★ = Allow 7 days for delivery

With square drive

ER-GB

Metric

DIN ISO 15488 (DIN 6499)

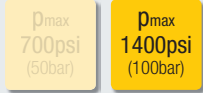
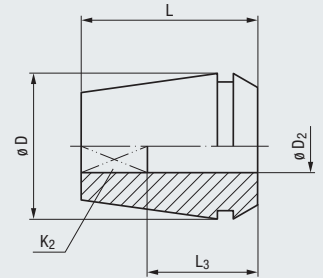

Type	ER 11 GB			ER 16 GB			ER 20 GB								
	M2 - M8			M4 - M12			M4 - M12								
Collet Dimensions (mm)	$\varnothing D$			$\varnothing D$			$\varnothing D$								
	L			L			L								
	11			16			20								
	18			27.5			31.5								
DIN															
mm				EDP Number		L ₃		EDP Number		L ₃		EDP Number		L ₃	
$\varnothing D_2$	K ₂														
2.8	2.1	M2 - M2.6	M4	F0942011.2.8	12	●									
3.5	2.7	M3	M4.5 - M5	F0942011.3.5	14	●									
4	3	M3.5	M5.5	F0942011.4	14	●									
4.5	3.4	M4	M6	F0942011.4.5	14	●	F0942016.4.5	15	●	F0942020.4.5	15	●			
6	4.9	M4.5 - M6	M8	F0942011.6	14	●	F0942016.6	18	●	F0942020.6	18	●			
7	5.5	M7	M9 - M10				F0942016.7	18	●	F0942020.7	18	●			
8	6.2	M8	M11				F0942016.8	22	●	F0942020.8	22	●			
9	7	M9	M12				F0942016.9	22	●	F0942020.9	22	●			
10	8	M10								F0942020.10	25	●			

Type	ER 25 GB			ER 32 GB			ER 40 GB			ER 50 GB					
	M4 - M20			M4 - M20			M10 - M30			M30 - M42					
Collet Dimensions (mm)	$\varnothing D$			$\varnothing D$			$\varnothing D$			$\varnothing D$					
	L			L			L			L					
	25			32			40			51					
	34			40			46			60					
DIN															
mm				EDP Number		L ₃		EDP Number		L ₃		EDP Number		L ₃	
$\varnothing D_2$	K ₂														
4.5	3.4	M4	M6	F0942025.4.5	15	●	F0942032.4.5	15	●						
6	4.9	M4.5 - M6	M8	F0942025.6	18	●	F0942032.6	18	●						
7	5.5	M7	M9 - M10	F0942025.7	18	●	F0942032.7	18	●						
8	6.2	M8	M11	F0942025.8	22	●	F0942032.8	22	●						
9	7	M9	M12	F0942025.9	22	●	F0942032.9	22	●	F0942040.9	22	●			
10	8	M10		F0942025.10	25	●	F0942032.10	25	●	F0942040.10	25	●			
11	9		M14	F0942025.11	25	●	F0942032.11	25	●	F0942040.11	25	●			
12	9		M16	F0942025.12	25	●	F0942032.12	25	●	F0942040.12	25	●			
14	11		M18	F0942025.14	25	●	F0942032.14	25	●	F0942040.14	25	●			
16	12		M20	F0942025.16	25	●	F0942032.16	25	●	F0942040.16	25	●			
18	14.5		M22 - M24							F0942040.18	25	●			
20	16		M27							F0942040.20	28	●			
22	18		M30							F0942040.22	28	●	F0942050.22	41	●
25	20		M33										F0942050.25	41	●
28	22		M36										F0942050.28	41	●
32	24		M39 - M42										F0942050.32	41	●

With square drive

ER-GB

Inch

DIN ISO 15488 (DIN 6499)

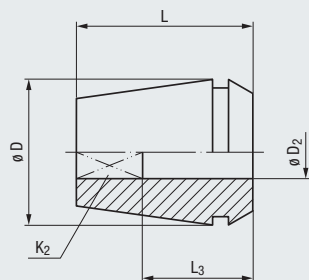

- Product Finder
- Soft-synchro
- Speed-synchro
- KSN
- MQL
- SFM
- HF
- EM
- Accessories
- Tech. Info

Type	ER 11 GB	ER 20 GB	ER 32 GB	ER 40 GB	ER 50 GB
	No.0 - No.6	No.8 - 1/2	1/4 - 3/4	1/4 - 1	1 - 1 1/2
Collet	$\varnothing D$ 0.433	0.787	1.260	1.575	2.008
Dimensions (inch)	L 0.709	1.240	1.575	1.811	2.362

ASME		inch				ER 11 GB		ER 20 GB		ER 32 GB		ER 40 GB		ER 50 GB		
$\varnothing D_2$	K ₂	EDP Number	L ₃			EDP Number	L ₃	EDP Number	L ₃	EDP Number	L ₃	EDP Number	L ₃	EDP Number	L ₃	
0.141	0.110	No.0-No.6		F0942011.3.58	0.55	●										
0.168	0.131	No.8		F0942011.4.27		●	F0942020.4.27	0.71	●							
0.194	0.152	No.10		F0942011.4.93		●	F0942020.4.93	0.71	●							
0.220	0.165	No.12					F0942020.5.59	0.71	●							
0.255	0.191	1/4					F0942020.6.48	0.71	●	F0942032.6.48	0.71	●	F0942040.6.48	0.71	●	
0.318	0.238	5/16					F0942020.8.08	0.87	●	F0942032.8.08	0.87	●	F0942040.8.08	0.87	●	
0.323	0.242		7/16				F0942020.8.20	0.87	●	F0942032.8.20	0.87	●	F0942040.8.20	0.87	●	
0.367	0.275		1/2				F0942020.9.32	0.87	●	F0942032.9.32	0.87	●	F0942040.9.32	0.87	●	
0.381	0.286	3/8					F0942020.9.68	0.87	●	F0942032.9.68	0.87	●	F0942040.9.68	0.87	●	
0.429	0.322		9/16							F0942032.10.90	0.98	●	F0942040.10.90	0.98	●	
0.4375	0.328	1/8 NPT								F0942032.11.11	0.98	●	F0942040.11.11	0.98	●	
0.480	0.360		5/8							F0942032.12.19	0.98	●	F0942040.12.19	0.98	●	
0.542	0.406		11/16							F0942032.13.77	0.98	●	F0942040.13.77	0.98	●	
0.5625	0.421	1/4 NPT								F0942032.14.29	0.98	●	F0942040.14.29	0.98	●	
0.590	0.442		3/4							F0942032.14.99	0.98	●	F0942040.14.99	0.98	●	
0.697	0.523		7/8										F0942040.17.70	0.98	●	
0.800	0.600		1										F0942040.20.32	1.10	●	
0.896	0.672		1 1/8											F0942050.20.32	1.61	●
1.021	0.766		1 1/4											F0942050.22.75	1.61	●
1.108	0.831		1 3/8											F0942050.25.93	1.61	●
1.233	0.925		1 1/2											F0942050.28.14	1.61	●
														F0942050.31.31	1.61	●

● = In stock
★ = Allow 7 days for delivery

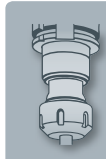

Without square drive

ER

Metric / Inch

DIN ISO 15488 (DIN 6499)

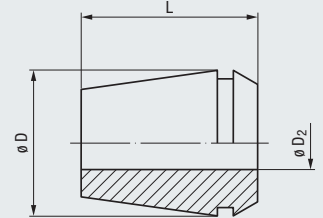
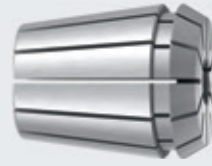

Type	ER 8		ER 11		ER 16		ER 20	
	1.5 - 4.5 mm 0.0591 - 0.1772		1.5 - 7 mm 0.0591 - 0.2756		2 - 10 mm 0.0787 - 0.3937		3 - 11 mm 0.1181 - 0.4331	
Collet	$\varnothing D$		$\varnothing D$		$\varnothing D$		$\varnothing D$	
Dimensions	L		L		L		L	
	8 mm (0.315)		11 mm (0.433)		16 mm (0.630)		20 mm (0.787)	
	13.6 mm (0.535)		18 mm (0.709)		27.5 mm (1.083)		31.5 mm (1.240)	
	$\varnothing D_2$							
	mm	inch	EDP Number		EDP Number		EDP Number	
	2 - 1.5	0.0787 - 0.0591	F0943008.2	●	F0943011.2	●		
	2.5 - 2	0.0984 - 0.0787	F0943008.2.5	●	F0943011.2.5	●		
	3 - 2.5	0.1181 - 0.0984	F0943008.3	●	F0943011.3	●		
	3 - 2	0.1181 - 0.0787				F0943016.3	●	
	3.5 - 3	0.1378 - 0.1181	F0943008.3.5	●	F0943011.3.5	●		
	4 - 3.5	0.1575 - 0.1378	F0943008.4	●	F0943011.4	●		
	4 - 3	0.1575 - 0.1181				F0943016.4	●	F0943020.4
	4.5 - 4	0.1772 - 0.1575	F0943008.4.5	●	F0943011.4.5	●		
	5 - 4.5	0.1969 - 0.1772				F0943011.5	●	
	5 - 4	0.1969 - 0.1575				F0943016.5	●	F0943020.5
	6 - 5.5	0.2362 - 0.2165			F0943011.6	●		
	6 - 5	0.2362 - 0.1969				F0943016.6	●	F0943020.6
	7 - 6.5	0.2756 - 0.2559			F0943011.7	●		
	7 - 6	0.2756 - 0.2362				F0943016.7	●	F0943020.7
	9 - 8	0.3543 - 0.3150				F0943016.9	●	F0943020.9
	10 - 9	0.3937 - 0.3543				F0943016.10	●	
	11 - 10	0.4331 - 0.3937						F0943020.11
	12 - 11	0.4724 - 0.4331						
	14 - 13	0.5512 - 0.5118						
	16 - 15	0.6299 - 0.5906						
	18 - 17	0.7087 - 0.6693						
	20 - 19	0.7874 - 0.7480						
	22 - 21	0.8661 - 0.8268						
	36 - 34	1.4173 - 1.3386						

Further designs upon request

PCM ET1

Metric

With square drive and length compensation on tension, not suitable for internal coolant supply

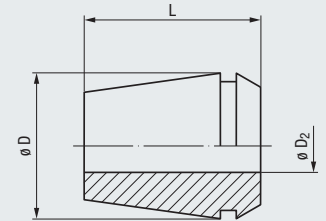

- Product Finder
- Soft-synchro
- Speed-synchro
- KSN
- MQL
- SFM
- HF
- EM
- Accessories
- Tech. Info



Type		PCM ET1-12		PCM ET1-20		PCM ET1-32		PCM ET1-40	
		M2 - M4		M2 - M10		M4 - M16		M4.5 - M20	
Collet Dimensions (mm)	T	5.5		7		10		13	
	ø D	11.5		21		33		41	
	L	21.5		31		43		54	
DIN									
mm									
ø D ₂	K ₂			EDP Number		EDP Number		EDP Number	
2.8	2.1	M2 - M2.6	M4	F0945011.2.8	★	F0945020.2.8	★		
3.5	2.7	M3	M4.5 - M5			F0945020.3.5	★		
4	3	M3.5	M5.5			F0945020.4	★		
4.5	3.4	M4	M6			F0945020.4.5	★	F0945032.4.5	★
6	4.9	M4.5 - M6	M8			F0945020.6	★	F0945032.6	★
7	5.5	M7	M9 - M10			F0945020.7	★	F0945032.7	★
8	6.2	M8	M11					F0945032.8	★
9	7	M9	M12					F0945032.9	★
10	8	M10						F0945032.10	★
11	9		M14					F0945032.11	★
12	9		M16					F0945032.12	★
14	11		M18						★
16	12		M20						★

The threading tool is clamped by means of 4 worm screws on the square

Further designs upon request

Due to the length compensation, sealing disks cannot be used in the clamping nut

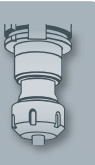

With square drive and length compensation on tension,
not suitable for internal coolant supply

PCM ET1
inch

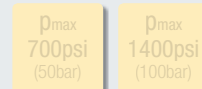
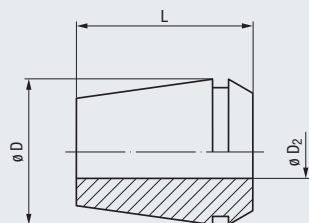

- Product Finder
- Soft-synchro
- Speed-synchro
- KSN
- MQL
- SFM
- HF
- EM
- Accessories
- Tech. Info

Type	PCM ET1-20	PCM ET1-32	PCM ET1-40
	1/4	1/4 - 5/8	1/4 - 7/8
Collet Dimensions (inch)			
T	0.276	0.394	0.512
ø D	0.827	1.299	1.614
L	1.220	1.693	2.126

ASME				EDP Number	*	EDP Number	*	EDP Number	*
inch									
ø D ₂	K ₂								
0.255	0.191	1/4		F0945020.6.48	★	F0945032.6.48	★	F0945040.6.48	★
0.318	0.238	5/16				F0945032.8.08	★	F0945040.8.08	★
0.381	0.286	3/8				F0945032.9.68	★	F0945040.9.68	★
0.323	0.242		7/16			F0945032.8.20	★	F0945040.8.20	★
0.367	0.275		1/2			F0945032.9.32	★	F0945040.9.32	★
0.429	0.322		9/16			F0945032.10.90	★	F0945040.10.90	★
0.480	0.360		5/8			F0945032.12.19	★	F0945040.12.19	★
0.590	0.442		3/4					F0945040.14.99	★
0.697	0.523		7/8					F0945040.17.70	★
0.800	0.600		1						
0.896	0.672		1 1/8						
1.021	0.766		1 1/4						
1.108	0.831		1 3/8						
1.233	0.925		1 1/2						
1.430	1.072		1 3/4						

The threading tool is clamped by means of 4 worm screws on the square

Further designs upon request

Due to the length compensation, sealing disks cannot be used in the clamping nut

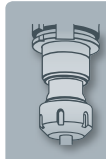

● = In stock
★ = Allow 7 days for delivery

DS/ER Metric / Inch DIN / ASME

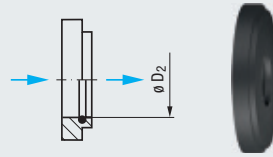

p_{max}
1400psi
(100bar)

- Product Finder
- Soft-synchro
- Speed-synchro
- KSN
- MQL
- SFM
- HF
- EM

Accessories

Tech. Info

Type				DS/ER 16	DS/ER 20	DS/ER 25	DS/ER 32	DS/ER 40	DS/ER 50	
DIN				EDP Number	EDP Number	EDP Number	EDP Number	EDP Number	EDP Number	
mm										
$\varnothing D_2$	K ₂									
4	3	M3.5	M5.5	F0941516.4	●					
4.5	3.4	M4	M6	F0941516.4.5	●	F0941520.4.5	●	F0941525.4.5	●	
6	4.9	M4.5 - M6	M8	F0941516.6	●	F0941520.6	●	F0941525.6	●	
7	5.5	M7	M9 - M10	F0941516.7	●	F0941520.7	●	F0941525.7	●	
8	6.2	M8	M11	F0941516.8	●	F0941520.8	●	F0941525.8	●	
9	7	M9	M12	F0941516.9	●	F0941520.9	●	F0941525.9	●	
10	8	M10		F0941516.10	●	F0941520.10	●	F0941525.10	●	
11	9		M14			F0941525.11	●	F0941532.11	●	
12	9		M16			F0941525.12	●	F0941532.12	●	
14	11		M18			F0941525.14	●	F0941532.14	●	
16	12		M20			F0941525.16	●	F0941532.16	●	
18	14.5		M22 - M24					F0941540.18	●	
20	16		M27					F0941540.20	●	
22	18		M30					F0941540.22	●	
25	20		M33						F0941550.22	★
28	22		M36						F0941550.25	★
32	24		M39 - M42						F0941550.28	★
36	29		M45 - M48						F0941550.32	★
									F0941550.36	★

Type				DS/ER 16	DS/ER 20	DS/ER 25	DS/ER 32	DS/ER 40	
ASME				EDP Number	EDP Number	EDP Number	EDP Number	EDP Number	
inch									
$\varnothing D_2$	K ₂								
0.141	0.110	No.1 - No.6		F0941516.4	●				
0.168	0.131	No.8		F0941516.4.5	●	F0941520.4.5	●	F0941525.4.5	●
0.194	0.152	No.10		F0941516.5	●	F0941520.5	●	F0941525.5	●
0.220	0.165	No.12		F0941516.6	●	F0941520.6	●	F0941525.6	●
0.255	0.191	1/4		F0941516.6.5	●	F0941520.6.5	●	F0941525.6.5	●
0.318	0.238	5/16		F0941516.8.5	●	F0941520.8.5	●	F0941525.8.5	●
0.323	0.242		7/16	F0941516.8.5	●	F0941520.8.5	●	F0941525.8.5	●
0.367	0.275		1/2	F0941516.9.5	●	F0941520.9.5	●	F0941525.9.5	●
0.381	0.286	3/8		F0941516.10	●	F0941520.10	●	F0941525.10	●
0.429	0.322		9/16			F0941525.11	●	F0941532.11	●
0.4375	0.328	1/8 NPT				F0941525.11.5	●	F0941532.11.5	●
0.480	0.360		5/8			F0941525.12.5	●	F0941532.12.5	●
0.5625	0.421	1/4 NPT				F0941525.14.5	●	F0941532.14.5	●
0.590	0.442		3/4			F0941525.15	●	F0941532.15	●
0.6875			1/2 NPT					F0941540.17.5	●
0.697	0.523		7/8					F0941540.18	●
0.700		3/8 NPT						F0941540.18	●
0.800	0.600		1					F0941540.20.5	●

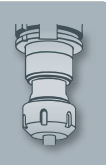



KS/ER

Metric

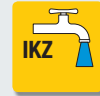
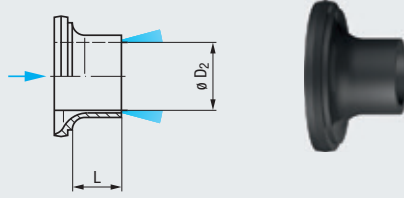
DIN



p_{max}
1400psi
(100bar)

Type				KS/ER 16			KS/ER 20			KS/ER 32					
DIN				EDP Number	L ₃	*	EDP Number	L ₃	*	EDP Number	L ₃	*			
ø D ₂	K ₂	mm													
4	3	M3.5	M5.5	F0941716.4	11	★									
6	4.9	M4.5 - M6	M8	F0941716.6	11	★	F0941720.6	11	★	F0941732.6	11	★			
7	5.5	M7	M9 - M10	F0941716.7	11	★	F0941720.7	11	★	F0941732.7	11	★			
8	6.2	M8	M11	F0941716.8	11	★	F0941720.8	11	★	F0941732.8	11	★			
9	7	M9	M12	F0941716.9	11	★	F0941720.9	11	★	F0941732.9	11	★			
10	8	M10		F0941716.10	2	★	F0941720.10	11	★	F0941732.10	11	★			
11	9		M14							F0941732.11	11	★			
12	9		M16							F0941732.12	11	★			
14	11		M18							F0941732.14	11	★			
16	12		M20							F0941732.16	11	★			

Product Finder

Soft-synchro

Speed-synchro

KSN

MQL

SFM

HF

EM

Accessories

Tech. Info



- Product Finder
- Soft-synchro
- Speed-synchro
- KSN
- MQL
- SFM
- HF
- EM
- Accessories
- Tech. Info

Hi-Q/ERM

Without sealing



p_{max}
1400psi
(100bar)

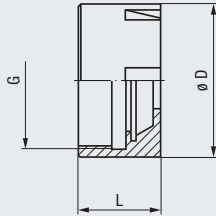

Type	Hi-Q/ERM 8	Hi-Q/ERM 11
Dimensions (mm)		
ϕD	12	16
L	10.8	12
G	M10 x 0.75	M13 x 0.75
For Collets	EDP Number	EDP Number
ER 8	F0940308 *	
ER 11 (GB)		F0940311 *

Hi-Q/ERMC

With integrated sealing



p_{max}
1400psi
(100bar)

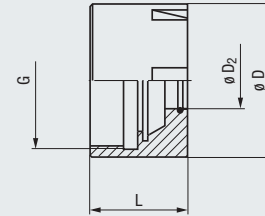

Type	Hi-Q/ERMC 11					
Dimensions (mm)	ϕD	16				
	L	14.6				
	G	M13 x 0.75				
DIN	mm		For Collets	EDP Number		
	ϕD_2	K_2				
	6	4.9	M4.5 - M6	M8	ER 11 (GB)	F0943511.6 *
	7	5.5	M7	M9 - M10	ER 11 (GB)	F0943511.7 *

Hi-Q/ERMC

For sealing disks



p_{max}
1400psi
(100bar)

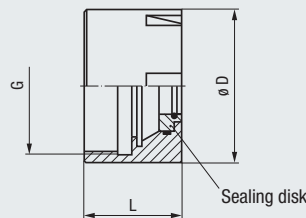

Type	Hi-Q/ERMC 16	Hi-Q/ERMC 20	Hi-Q/ERMC 25
Dimensions (mm)			
ϕD	22	28	35
L	22	24	25
G	M19 x 1	M24 x 1	M30 x 1
For Collets	Sealing Disks	EDP Number	EDP Number
ER 16 (GB)	DS/ER 16	F0943516 *	
ER 20 (GB)	DS/ER 20	F0943520 *	
ER 25 (GB)	DS/ER 25		F0943525 *

Sealing disks are not included in the delivery, please order separately (see page 616)

Without sealing

Hi-Q/ER

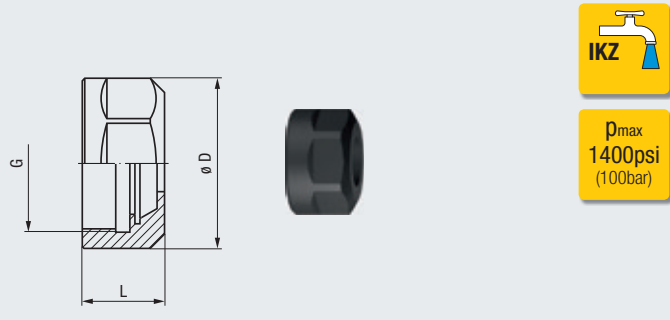

p_{max}
1400psi
(100bar)

Type	Hi-Q/ER 11	
Dimensions (mm)	ø D	19
	L	11.3
	G	M14 x 0.75
For Collets	EDP Number	
ER 11 (GB)	F0940911	★

With integrated sealing

Hi-Q/ERC

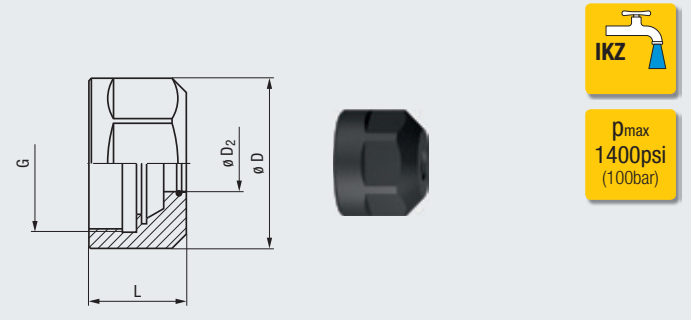

p_{max}
1400psi
(100bar)

Type	Hi-Q/ERC 11						
Dimensions (mm)	ø D	19					
	L	14.6					
	G	M14 x 0.75					
DIN	mm		For Collets	EDP Number			
	ø D ₂	K ₂					
	6	4.9	M4.5 - M6	M8	ER 11 (GB)	F0940711.6	★
	7	5.5	M7	M9 - M10	ER 11 (GB)	F0940711.7	★

For sealing disks

Hi-Q/ERC

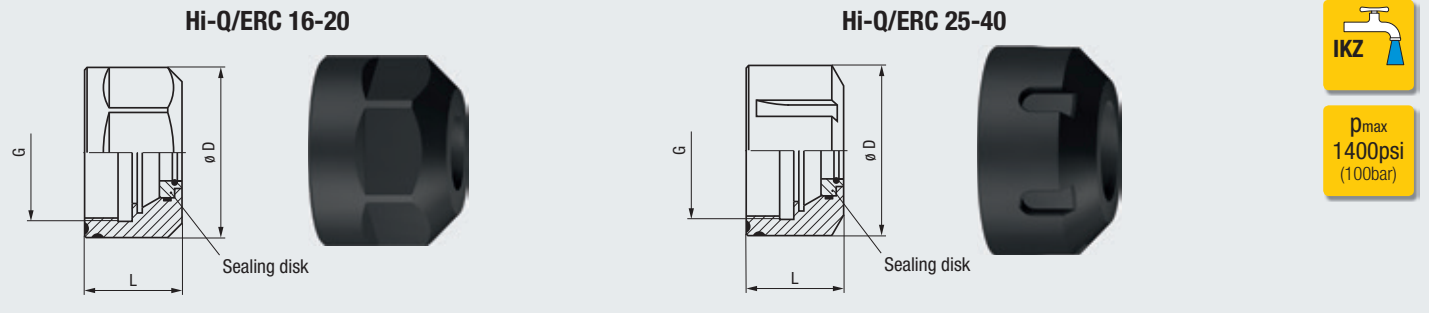

p_{max}
1400psi
(100bar)

Type	Hi-Q/ERC 16		Hi-Q/ERC 20		Hi-Q/ERC 25		Hi-Q/ERC 32		Hi-Q/ERC 40		
Dimensions (mm)	ø D	28	34	42	50	63					
	L	22.5	24	25	27.5	30.5					
	G	M22 x 1.5	M25 x 1.5	M32 x 1.5	M40 x 1.5	M50 x 1.5					
For Collets	Sealing Disks	EDP Number	EDP Number	EDP Number	EDP Number	EDP Number					
ER 16 (GB)	DS/ER 16	F0940716	★	F0940720	★	F0940725	★	F0940732	★	F0940740	★
ER 20 (GB)	DS/ER 20										
ER 25 (GB)	DS/ER 25										
ER 32 (GB)	DS/ER 32										
ER 40 (GB)	DS/ER 40										

Sealing disks are not included in the delivery, please order separately (see page 616)

● = In stock
★ = Allow 7 days for delivery

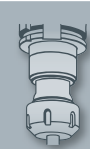

For sealing disks

Hi-Q/ERBC



p_{max}
1400psi
(100bar)

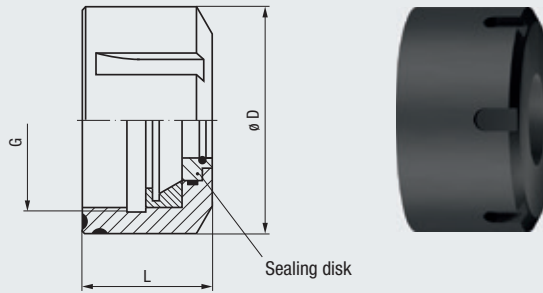

Type		Hi-Q/ERBC 50 AF					
Dimensions (mm)	ϕD	77.7					
	L	42.5					
	G	M64 x 2					
For Collets	Sealing Disks	EDP Number					
ER 50 (GB)	DS/ER 50	F0941650	★				

Sealing disks are not included in the delivery, please order separately (see page 616)

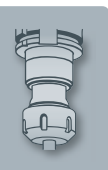

Sets of clamping wrenches

Softsynchro®

Softsynchro® Micro, Softsynchro® 0



Softsynchro® 1



Softsynchro® 3, Softsynchro® 4



Softsynchro® 5



- Product Finder
- Softsynchro
- Speedsynchro
- KSN
- MQL
- SFM
- HF
- EM
- Accessories
- Tech. Info

For Collet Holders	Components	EDP Number	
Softsynchro® Micro	E8M / SW8	F315098.03	★
Softsynchro® 0	E11M / SW14	F315098.02	★
Softsynchro® 1	SW30 / SW19	F315198.02	★
Softsynchro® 1 for driven tools	SW25 / SW17	F315198.03	★
Softsynchro® 3	E32 / SW32	F315398.01	★
Softsynchro® 4	E40 / SW41	F315498.01	★
Softsynchro® 5	E50	F315598.02	★

Assembly device

Softsynchro®

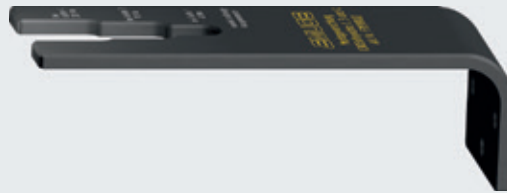

For Collet Holders	EDP Number	
Softsynchro® 1 - Softsynchro® 4	F315199.02	★

Assembly device

Speedsynchro® Modular



For Collet Holders with Integrated Transmission	EDP Number	
Speedsynchro® Modular	F3741909	★



● = In stock
★ = Allow 7 days for delivery

- Product Finder
- Soft-synchro
- Speed-synchro
- KSN
- MQL
- SFM
- HF
- EM
- Accessories
- Tech. Info

KSN/HD/ER

Sets of clamping wrenches

KSN 1/HD/ER



KSN 3/HD/ER



	For Collet Holders	Components	EDP Number	
	KSN 1/HD/ER	E20M / SW24	F323198.01	★
	KSN 3/HD/ER	E32 / SW34	F323398.01	★

EM-L/ER/IKZ

Sets of clamping wrenches

EM 00-L/ER/IKZ - EM 03-L/ER/IKZ



	For Collet Holders	Components	EDP Number	
	EM 00-L/ER/IKZ	E11M / SW11	F350098.01	★
	EM 01-L/ER/IKZ	E16M / SW17	F350198.01	★
	EM 03-L/ER/IKZ	E25M / SW26	F350398.01	★

Hi-Q/ER, Hi-Q/ERC

Clamping wrenches

Hi-Q/ER 11, Hi-Q/ERC 20



Hi-Q/ERC 32, Hi-Q/ERC 40



	For Clamping Nuts	EDP Number	
	Hi-Q/ER 11	QB002002.00170	★
	Hi-Q/ERC 20	QB002002.00300	★
	Hi-Q/ERC 32	QB002003.0320	★
	Hi-Q/ERC 40	QB002003.0400	★

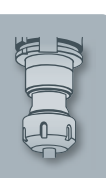

Torque wrenches

TORCO-FIX

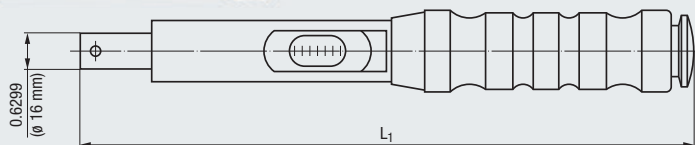

Type	Torque		inch L ₁	EDP Number	
	ft lbs	Nm			
TORCO-FIX 0	4 - 18	5 - 25	11.417	F0908002	★
TORCO-FIX I	7 - 37	10 - 50	13.189	F0908005	★
TORCO-FIX II	30 - 148	40 - 200	18.307	F0908020	★
TORCO-FIX III	44 - 221	60 - 300	22.244	F0908060	★

Type	For Clamping Nuts	TORCO-FIX	inch		EDP Number	
			A	B		
A-E 8 M	Hi-Q/ERM 8	0	0.488	2.087	F0908500.AE8M	★
A-E 11 M	Hi-Q/ERM 11, Hi-Q/ERM 11	0	0.661	2.126	F0908500.AE11M	★
A-E 16 M	Hi-Q/ERM 16	I	0.886	2.205	F0908500.AE16M	★
A-E 20 M	Hi-Q/ERM 20	I	1.142	2.677	F0908500.AE20M	★
A-E 25 M	Hi-Q/ERM 25	I	1.417	2.756	F0908500.AE25M	★

Shell-type wrenches

A-EM

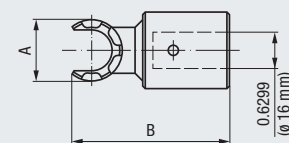

Type	For Clamping Nuts	TORCO-FIX	inch		EDP Number	
			A	B		
A-E 11 P	Hi-Q/ERC 11, Hi-Q/ER 11	0	1.260	2.402	F0908500.AE11P	★
A-E 16 P	Hi-Q/ERC 16	I	1.732	2.795	F0908500.AE16P	★
A-E 20 P	Hi-Q/ERC 20	I	2.047	3.189	F0908500.AE20P	★

Shell-type wrenches

A-EP

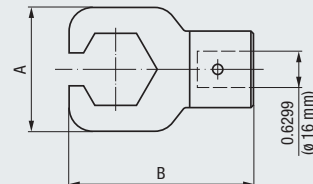

Type	For Clamping Nuts	TORCO-FIX	inch		EDP Number	
			A	B		
A-E 25	Hi-Q/ERC 25	II, III	2.756	2.835	F0908500.AE25	★
A-E 32	Hi-Q/ERC 32	II, III	3.150	2.835	F0908500.AE32	★
A-E 40	Hi-Q/ERC 40	III	3.780	3.228	F0908500.AE40	★
A-E 50	Hi-Q/ERBC 50	III	4.370	3.701	F0908500.AE50	★

Shell-type wrenches

A-E

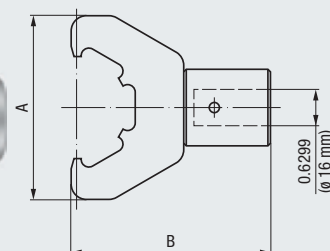
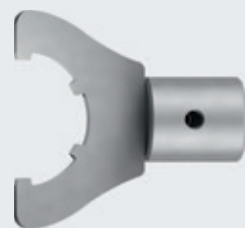

● = In stock
★ = Allow 7 days for delivery

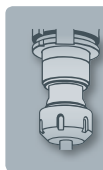

- Product Finder
- Soft-synchro
- Speed-synchro
- KSN
- MQL
- SFM
- HF
- EM
- Accessories
- Tech. Info

Metric

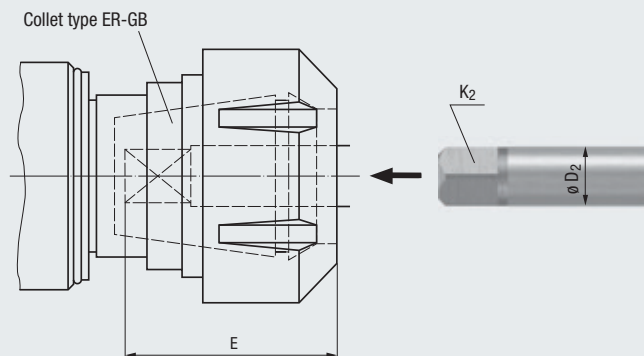

Collets				ER 8		ER 11 GB			ER 16 GB	
Clamping Nuts				Hi-Q/ERM 8		Hi-Q/ERM 11	Hi-Q/ER 11	Hi-Q/ERMC 11 Hi-Q/ERC 11	Hi-Q/ERMC 16 Hi-Q/ERC 16	
DIN				Clamping Depths E mm		Clamping Depths E mm				
mm				min.	max.					
∅ D ₂	K ₂									
2	–	M0.5 - M0.9		9	20					
2.2	–		M3	9	20					
2.5	2.1	M1 - M1.8	M3.5	14	20					
2.8	2.1	M2 - M2.6	M4	15	20					
3.5	2.7	M3	M4.5 - M5	15	19.5	18	17	21		
4	3	M3.5	M5.5	15	19	21	20	24		
4.5	3.4	M4	M6	15	19	21	20	24		26
6	4.9	M4.5 - M6	M8			23	22	26		31
7	5.5	M7	M9 - M10							31
8	6.2	M8	M11							36
9	7	M9	M12							37 / 48 1)
10	8	M10								43 1)

1) In combination with collets type ER 16 and Softsynchro® 1 for driven tools

Collets				ER 20 GB		ER 25 GB		ER 32 GB		ER 40 GB		ER 50 GB	
Clamping Nuts				Hi-Q/ERMC 20 Hi-Q/ERC 20		Hi-Q/ERMC 25 Hi-Q/ERC 25		Hi-Q/ERC 32		Hi-Q/ERC 40		Hi-Q/ERBC 50 AF	
DIN				Clamping Depths E mm									
mm													
∅ D ₂	K ₂												
4.5	3.4	M4	M6	26	26	26							
6	4.9	M4.5 - M6	M8	31	31	31							
7	5.5	M7	M9 - M10	31	31	31							
8	6.2	M8	M11	36	36	36							
9	7	M9	M12	37	37	37				37			
10	8	M10		41	41	41				41			
11	9		M14		42	42				42			
12	9		M16		42	42				42			
14	11		M18		44	44				44			
16	12		M20		45	45				45			
18	14.5		M22 - M24							47			
20	16		M27							52			
22	18		M30							54			70
25	20		M33										72
28	22		M36										74
32	24		M39 - M42										76
36	29		M45 - M48										111 2)

2) In combination with collets type ER 50 and Softsynchro® 5

Inch

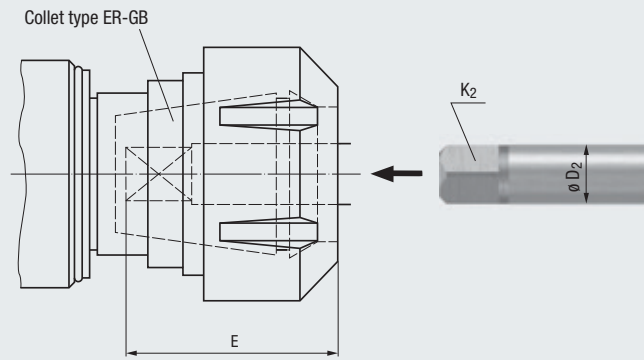

Collets		ER 8		ER 11 GB		
Clamping Nuts		Hi-Q/ERM 8		Hi-Q/ERM 11	Hi-Q/ER 11	Hi-Q/ERMC 11 Hi-Q/ERC 11
ASME		Clamping Depths E inch		Clamping Depths E inch		
inch						
ø D ₂	K ₂	min.	max.			
0.141	0.110	0.59	0.75	0.78	0.74	0.90
0.168	0.131	0.59	0.75			

Collets		ER 20 GB	ER 32 GB	ER 40 GB	ER 50 GB
Clamping Nuts		Hi-Q/ERMC 20 Hi-Q/ERC 20	Hi-Q/ERC 32	Hi-Q/ERC 40	Hi-Q/ERBC 50 AF
ASME		Clamping Depths E inch			
inch					
ø D ₂	K ₂				
0.168	0.131	1.16			
0.194	0.152	1.16			
0.220	0.165	1.19			
0.255	0.191	1.22	1.22	1.22	
0.318	0.238	1.45	1.45	1.45	
0.323	0.242	1.48	1.48	1.48	
0.367	0.275	1.51	1.51	1.51	
0.381	0.286	1.51	1.51	1.51	
0.429	0.322	1.68	1.68	1.68	
0.4375	0.328	1.56	1.56	1.56	
0.480	0.360	1.74	1.74	1.74	
0.542	0.406	1.81	1.81	1.81	
0.5625	0.421	1.62	1.62	1.62	
0.590	0.442	1.87	1.87	1.87	
0.697	0.523	1.93	1.93	1.93	
0.800	0.600			2.11	2.73
0.896	0.672				2.80
1.021	0.766				2.92
1.108	0.831				2.98
1.233	0.925				3.05

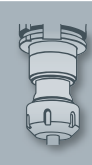

- Product Finder
- Soft-synchro
- Speed-synchro
- KSN
- MQL
- SFM
- HF
- EM
- Accessories
- Tech. Info

DEU

Single-armed torque wrench

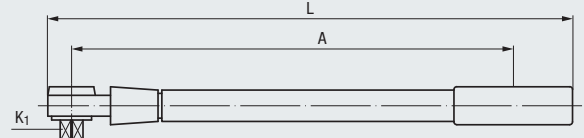

Type	For Adapter Size	Torque		Measuring Range	inch			EDP Number	
		ft lbs	Nm		A	L	k ₁		
DEU-00/1	00	0 - 4.43	0 - 6	M2 - M6 (No.2 - No.12)	8.6614	10.2362	1/4	F0900001	★
DEU-00/1	00/01 (03)	2.21 - 18.44	3 - 25	M6 - M12 (No.10 - 7/16)	7.8740	9.6457	3/8	F0900004	★
DEU-10/1	03/04	14.75 - 147.52	20 - 200	M12 - M27 (7/16 - 1)	16.1417	19.6850	1/2	F0901002	★
DEU-20/1	04/05	51.63 - 516.32	70 - 700	M24 - M52 (7/8 - 1 3/4)	45.2756	49.6063	3/4	F0902002	★

DEU

Double-armed torque wrench

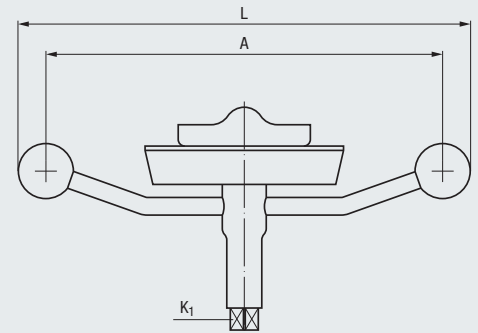

Type	For Adapter Size	Torque		Measuring Range	inch			EDP Number	
		ft lbs	Nm		A	L	k ₁		
DEU-00/1	00	2.21 - 16.96	3 - 23 Nm	M6 - M12 (No.10 - 7/16)	7.0866	8.0709	3/8	F0900000	upon request
DEU-00/1	00/01 (03)	14.75 - 132.77	20 - 180 Nm	M12 - M27 (7/16 - 1)	24.4094	25.8268	1/2	F0901000	upon request
DEU-20/1	04/05	51.63 - 516.32	70 - 700 Nm	M24 - M52 (7/8 - 1 3/4)	45.2756	51.1811	3/4	F0902000	upon request

AEU

Adapter head

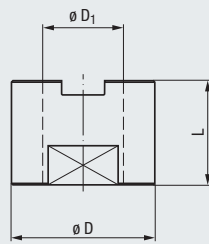

Type	For Adapter Size	inch			EDP Number	
		ø D	ø D ₁	L		
AEU-00	00	0.9843	0.5118	0.9843	F0920000	★
AEU-01	01	1.3780	0.7480	1.1024	F0921000	★
AEU-03	03	2.1654	1.2205	1.5748	F0923000	★
AEU-04	04	2.9528	1.8898	2.3622	F0924000	★
AEU-05	05	3.9370	2.3622	2.7559	F0925000	★

VS

Spanner with pins

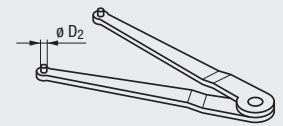

Type	For Adapter Size	inch	EDP Number	
		ø D ₂		
VS-00	00	0.0787	F0930000	★
VS-01	01	0.0984	F0931000	★
VS-03	03	0.1575	F0933000	★
VS-04	04	0.1969	F0934000	★
VS-05	05	0.2362	F0935000	★

The adapter head serves for holding the quick-change adapters and features clamping flats for holding in a vise

VEU

Square pin



Type	For Adapter Size	inch		mm		EDP Number		inch		EDP Number	
		K ₁		ø D ₂	K ₂			ø D ₂	K ₂		
VEU-00	DEU-00	3/8		2.5	2.1	F0910100	●	0.141	0.110	F0910300	●
				2.8	2.1	F0910101	●	0.168	0.131	F0910301	●
				3.5	2.7	F0910102	●	0.194	0.152	F0910302	●
				4	3	F0910103	●	0.220	0.165	F0910303	●
				4.5	3.4	F0910104	●	0.255	0.191	F0910304	●
				6	4.9	F0910106	●	0.318	0.238	F0910306	●
				7	5.5	F0910107	●	0.323	0.242	F0910307	●
				8	6.2	F0910108	●	0.367	0.275	F0910310	●
				9	7	F0910109	●	0.381	0.286	F0910311	●
				10	8	F0910110	●				
				11	9	F0910111	●				
				12	9	F0910112	●				
				14	11	F0910113	●				
				16	12	F0910114	●				
				18	14.5	F0910115	●				
VEU-10	DEU-10	1/2		4.5	3.4	F0911104	●	0.318	0.238	F0911306	●
				6	4.9	F0911106	●	0.323	0.242	F0911307	●
				7	5.5	F0911107	●	0.367	0.275	F0911310	●
				8	6.2	F0911108	●	0.381	0.286	F0911311	●
				9	7	F0911109	●	0.429	0.322	F0911313	●
				10	8	F0911110	●	0.480	0.360	F0911315	●
				11	9	F0911111	●	0.590	0.442	F0911319	●
				12	9	F0911112	●	0.697	0.523	F0911323	●
				14	11	F0911113	●	0.800	0.600	F0911325	●
				16	12	F0911114	●	0.896	0.672	F0911326	●
				18	14.5	F0911115	●	1.021	0.766	F0911327	●
				20	16	F0911116	●	1.108	0.831	F0911328	●
				22	18	F0911117	●	0.3125	0.234	F0911350	●
				25	20	F0911118	●	0.4375	0.328	F0911351	●
				28	22	F0911119	●	0.5625	0.421	F0911352	●
	32	24	F0911120	●	0.6875	0.515	F0911353	●			
	36	29	F0911121	●	0.700	0.531	F0911354	●			
					0.9063	0.679	F0911355	●			
					1.125	0.843	F0911356	●			
VEU-20	DEU-20	3/4		18	14.5	F0912115	●	0.697	0.523	F0912323	●
				20	16	F0912116	●	0.800	0.600	F0912325	●
				22	18	F0912117	●	0.896	0.672	F0912326	●
				25	20	F0912118	●	1.021	0.766	F0912327	●
				28	22	F0912119	●	1.108	0.831	F0912328	●
				32	24	F0912120	●	1.233	0.925	F0912329	●
				36	29	F0912121	●	1.305	0.979	F0912330	●
				40	32	F0912122	●	1.430	1.072	F0912331	●
				45	35	F0912123	●	1.519	1.139	F0912332	●
								1.644	1.233	F0912333	●
								0.700	0.531	F0912354	●
								0.9063	0.679	F0912355	●
								1.125	0.843	F0912356	●

These square pins establish the connection between torque wrench and adapter:
the square K₁ is inserted into the square seat of the torque wrench, and the shank end D₂ with square K₂ is clamped in the adapter



- Product Finder
- Soft-synchro
- Speed-synchro
- KSN
- MQL
- SFM
- HF
- EM

Setting and checking of the overload clutch on quick-change adapters of types EM-U, EM-UL and HF:

Generally speaking, the torque to be set depends on

- Size
- Geometry and coating of the tool
- Workpiece material
- Type and quality of the coolant-lubricant
- Drilled hole diameter

The table contains standard values for thread cutting in steel with a tensile strength of 600-800 N/mm².

These values generally need to be adjusted to the individual work case (e.g. for cold-forming of threads).

Torque		Thread type					
Nm	ft lbs	UNC	UNF	M	G (Whw.) BSP	NPT NPTF	Rc (BSPT)
0.3	0.2	No. 2	No. 2	M2			
0.4	0.3		No. 3	M2.5			
0.5	0.4	No. 3	No. 4				
0.6	0.5			M3			
0.8	0.6	No. 4	No. 5				
1	0.7	No. 5	No. 6	M3.5			
1.2	0.9	No. 6	No. 8				
1.6	1.2	No. 8		M4			
2	1.5		No. 10				
2.5	1.8		No. 12	M5			
3	2.2	No. 10	1/4				
4	3	No. 12					
5	3.7		5/16	M6			
6	4.4	1/4	3/8		G 1/8		
8	6						
10	7.4	5/16	7/16	M8			
12	8.9		1/2				
16	12	3/8				1/16	Rc 1/16
18	13		9/16	M10	G 1/4		
20	15		5/8				
22	16	7/16			G 3/8		
25	18			M12		1/8	Rc 1/8
28	21						
32	24	1/2	3/4				
40	30	9/16					
45	33		7/8	M14			
50	37	5/8		M16	G 1/2		
56	41				G 5/8		Rc 1/4
63	46					1/4	
70	52	3/4	1		G 3/4		
80	59		1 1/8	M18	G 7/8		
90	66		1 1/4	M20		3/8	Rc 3/8
100	74	7/8	1 3/8	M22			
110	81		1 1/2				
125	92						
140	103	1		M24	G 1		
160	118			M27	G 1 1/8	1/2	Rc 1/2
180	133				G 1 1/4		
200	148				G 1 3/8	3/4	Rc 3/4

Torque		Thread type					
Nm	ft lbs	UNC	UNF	M	G (Whw.) BSP	NPT NPTF	Rc (BSPT)
220	162	1 1/8		M30	G 1 1/2		
240	177	1 1/4		M33	G 1 3/4		
260	192				G 2		
280	207			M36			
300	221				G 2 1/4		
320	236			M39			
340	250	1 3/8			G 2 1/2	1	Rc 1
360	266	1 1/2			G 2 3/4		
400	295			M42	G 3		
420	310			M45	G 3 1/4		
450	332				G 3 1/2	1 1/4	Rc 1 1/4
480	354				G 3 3/4		
500	369				G 4		
560	413			M48		1 1/2	Rc 1 1/2
630	465	1 3/4		M52			
710	524			M56		2	Rc 2
800	590			M60			
900	664			M64			
1000	738	2		M68			
1100	811	2 1/4					
1170	863			M72			
1230	907			M76			
1300	959			M80			
1380	1018			M85			
1400	1033	2 1/2				2 1/2	Rc 2 1/2
1460	1077			M90			
1540	1136			M95			
1620	1195			M100			
1700	1254			M105			
1780	1313			M110			
1860	1372			M115			
1940	1431			M120			
2000	1475	2 3/4				3	Rc 3
2020	1490			M125			
2110	1556			M130			
2200	1623						
2270	1674			M140			
2430	1792			M150			
2680	1977			M160			

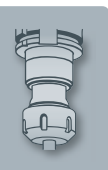

- Product Finder
- Soft-synchro
- Speed-synchro
- KSN
- MQL
- SFM
- HF
- EM
- Accessories
- Tech. Info

PGR-GB

With square drive and length adjustment

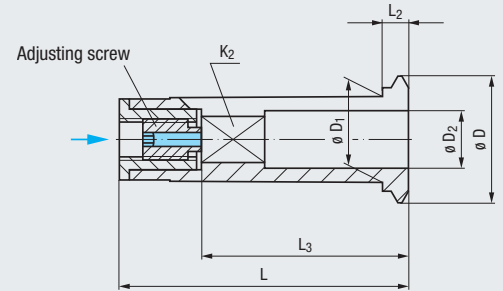
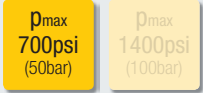

Type	PGR 15 GB	PGR 25 GB
	M4 - M12	M8 - M20
Collet Dimensions (mm)		
$\varnothing D$	22	33
$\varnothing D_1$	15	25
L	50.5	60.5
L ₂	4.5	6

DIN				EDP Number	mm		★	EDP Number	mm		★
$\varnothing D_2$	K ₂				L ₃				L ₃		
4.5	3.4	M4	M6	F0942615.4.5	min. 27	max. 29	★				
6	4.9	M4.5 - M6	M8	F0942615.6	29	31	★				
7	5.5	M7	M9 - M10	F0942615.7	29	31	★				
8	6.2	M8	M11	F0942615.8	33.5	36	★	F0942625.8	33.5	36	★
9	7	M9	M12	F0942615.9	34.5	37	★	F0942625.9	34.5	37	★
10	8	M10		F0942615.10	35.5	38	★	F0942625.10	38.5	41	★
11	9		M14					F0942625.11	39.5	42	★
12	9		M16					F0942625.12	39.5	42	★
14	11		M18					F0942625.14	41.5	44	★
16	12		M20					F0942625.16	42.5	45	★

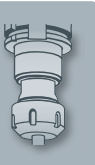

Technical Information

		Page
7.1	Description of the symbols for performance characteristics	632 - 635
7.2	Assembly of sealing disk, collet and tool	636
7.3	Overview of hollow taper shanks with flange contact surface (HSK)	637
7.4	Rigid tapping	638 - 641
7.5	Tool monitoring system DDU4	641
7.6	Collet holders Softsynchro® Modular	642 - 643
7.7	Minimum-quantity lubrication (MQL)	644
7.8	Collet holders Speedsynchro® Modular	645 - 646
7.9	Adjusting the overload clutch of quick-change tap holders type HF	647 - 648
7.10	Cleaning of collet holder and collet type PGR	649
7.11	Length adjustment of collet holders type PGR	650

Product
FinderSoft-
synchroSpeed-
synchro

KSN

MQL

SFM

HF

EM

Accessories

Tech. Info



- Product Finder
- Soft-synchro
- Speed-synchro
- KSN
- MQL
- SFM
- HF
- EM
- Accessories
- Tech. Info

7.1 Description of the symbols for performance characteristics



Internal coolant supply (IKZ)

If a machine tool is equipped with internal coolant supply through the machine spindle, then the thread production cycle can be done with special economic efficiency by conducting the coolant-lubricant through the axial bore in the tool, or along the tool shank.

The advantages of this arrangement are:

- Perfect lubrication at the cutting edge of the tool
- Improved thread quality
- Chips are washed out of the thread hole

It is, however, necessary to make sure that the coolant-lubricant used is appropriately filtered and that the tap holder used is suitable for the coolant pressure of the machine. Depending on the design of the tool, with or without internal coolant supply, the quick-change adapters are available in two versions:

Conduction of internal coolant supply with tools with IKZ

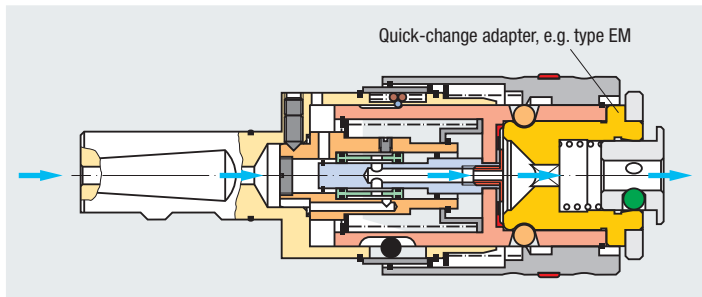

Conduction of internal coolant supply with tools without IKZ

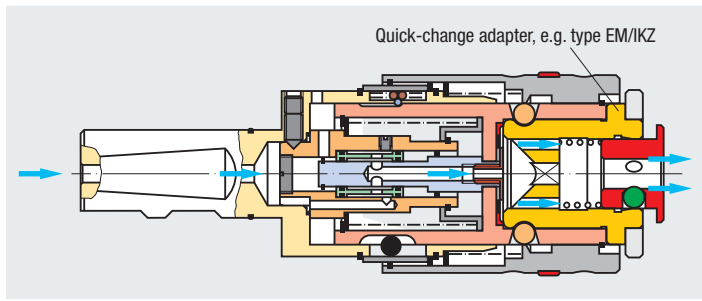

Minimum-quantity lubrication (MQL)

Suitable for machines which are equipped with a central minimum-quantity lubrication system – this is often called “dry machining”. In addition to the advantages described under “IKZ” this lubrication technology is very friendly to the environment. The high cutting data common in wet machining can be used without any change.

Another advantage is the reduction of costs, since there is no need to purchase and maintain expensive filter installations, or to dispose of used emulsions.

For more detailed information, see **7.6 Minimum-quantity lubrication (MQL)**.

MQL
1

Minimum-quantity lubrication (1-channel MQL system)

In a **1-channel MQL** system, the aerosol is generated in the MQL device before it enters into the machine spindle, and is then conducted through the work spindle and the clamping system to the point where it is needed.

For more detailed information, see **7.6 Minimum-quantity lubrication (MQL)**.

MQL
2

Minimum-quantity lubrication (2-channel MQL system)

In a **2-channel MQL** system, oil and air are conducted through the spindle separately, the mixing of the two media is done only at the point where they enter the tool holder.

For more detailed information, see **7.6 Minimum-quantity lubrication (MQL)**.

p_{max}
85psi
(6bar)

p_{max}
140psi
(10bar)

p_{max}
700psi
(50bar)

p_{max}
1400psi
(100bar)

Coolant pressure at the entry to the holder

For the sake of trouble-free operation of the tool holders, it is vital not to exceed the specified maximum coolant pressures.

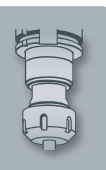

7.1 Description of the symbols for performance characteristics



Length compensation on compression and tension

Length compensation on compression

This type of length compensation compensates differences between spindle feed and the pitch of the thread to be produced. If a quick-change adapter with overload clutch is used, the length compensation on compression accommodates spindle feed as soon as the overload clutch responds.

Activated length compensation on compression at

- Plus programming of the control
- Overload on the quick-change adapter with overload clutch

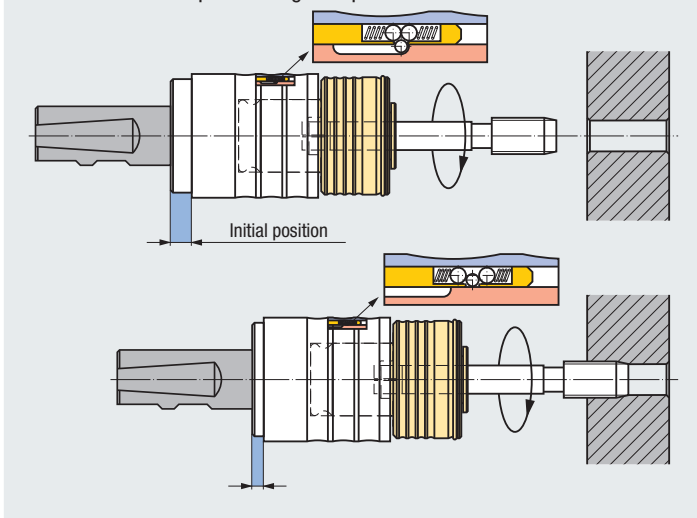

Length compensation on tension

This type of length compensation compensates differences between spindle feed and the pitch of the thread to be produced, as well as a spindle overrun at the point of reversal of the thread production cycle. With the tapping attachments, the length compensation on tension assumes the function of switching the sense of rotation from right-hand to left-hand rotation.

Activated length compensation on tension at

- Minus programming of the control
- Manual retraction

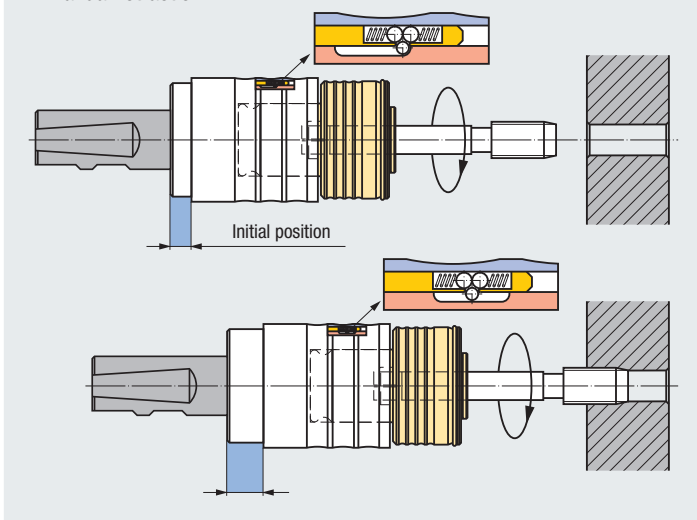

Minimal length compensation

An integrated minimal length compensation on compression and tension compensates minimal pitch differences between synchronous spindle and tool which would lead to excessive friction forces on the thread flanks. A possible increase of axial force during the thread production cycle is reduced to a minimum.

The resulting advantages are:

- No miscut threads
- Optimized tool life
- Suitable for internal coolant supply

For more detailed information, see 7.4 Rigid tapping.



Pressure-point mechanism

The patented pressure-point mechanism guarantees a safe start of the thread cutting process. The length compensation movement is released by the pressure-point mechanism only when the effective axial force exceeds the normal, permissible start-of-cut force. This helps to achieve reproducible, uniform thread depths.

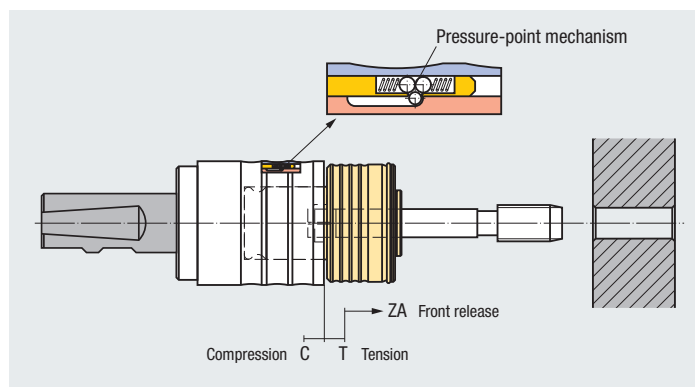

- Product Finder
- Soft-synchro
- Speed-synchro
- KSN
- ML
- SFM
- HF
- EM
- Accessories

Tech. Info

7.1 Description of the symbols for performance characteristics



Front release

The front release protects the quick-change tap holder, the quick-change adapter and the tool, as well as the workpiece, against damage caused by excessive axial tension. Such tension may occur if the length compensation path is exceeded due to afterrunning of the spindle at the point of reversal, or when the fast-feed function of the tool retraction movement is activated before the tool has come free from the workpiece. In these situations, the quick-change adapter is detached from the holder automatically, avoiding expensive damage.

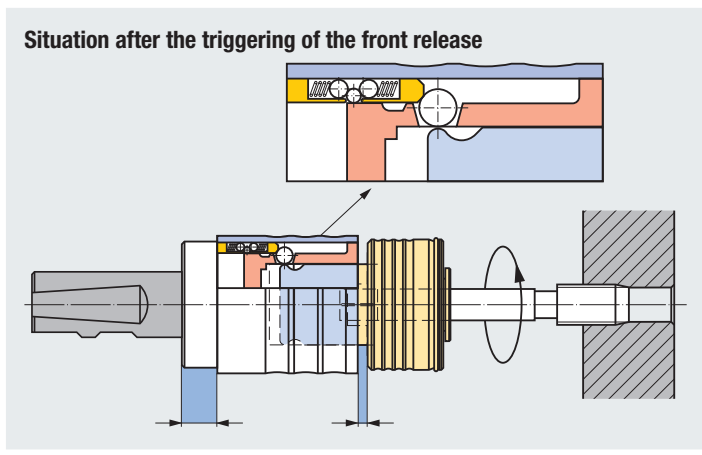
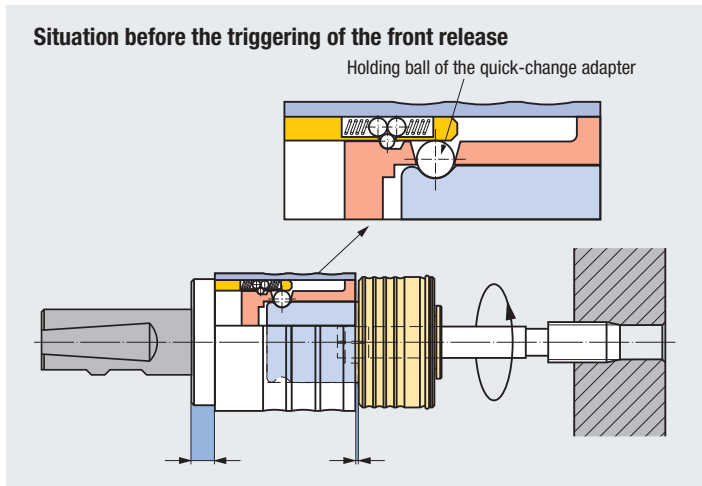

Transmission gearing rapid traverse

Due to the integrated transmission gearing rapid traverse, the spindle speed is multiplied. Consequently the threading tool speed is increased by the transmission factor.



Axial-parallel floating

A ball-based floating system guarantees that small errors of alignment between machine spindle and thread hole, or concentricity run-out on the side of the machine spindle, are compensated.

Two parallel drilled holes, offset by 90°, form a precise ball-based linear guide. This arrangement is the perfect solution for the function of the "parallel floating" feature.

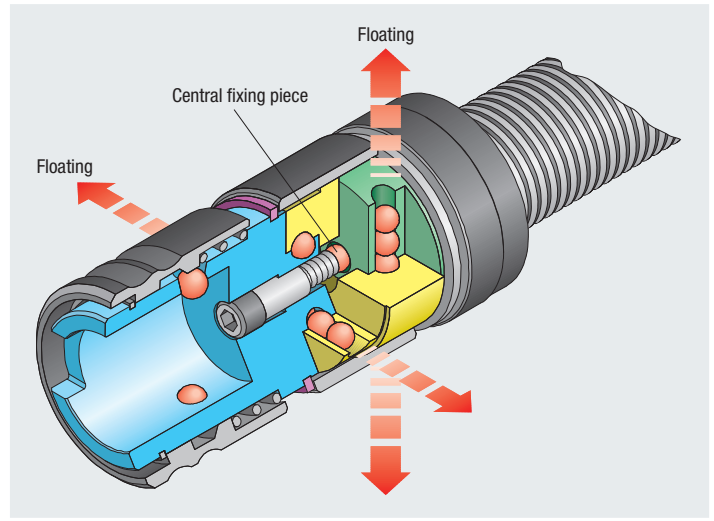

Overload clutch

The **wave-line profile overload clutch** as developed by EMUGE is characterized by its great wear resistance. Grease chambers between the upper and lower clutch ring provide permanent lubrication during the overload process. When the set torque is exceeded during a threading process, the overload clutch immediately interrupts the torque transfer between machine spindle and tool. This protects the tap against damage.

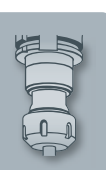
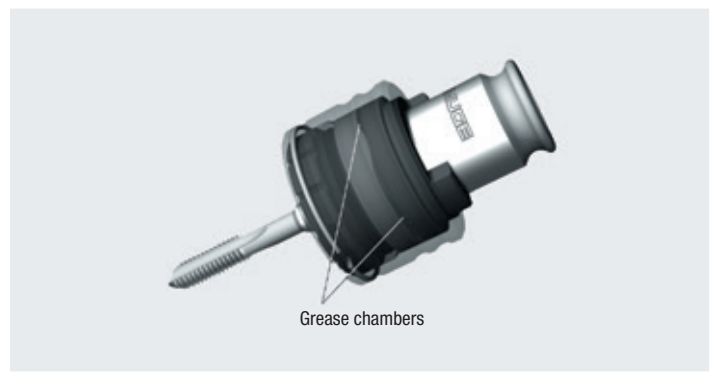

7.1 Description of the symbols for performance characteristics



Length adjustment

With the length adjustment, the projection length of the quick-change adapter can be re-adjusted or increased in case of need.



Length adjustment by 2 mm

The projecting length of the tool can be extended by 2 mm (0.0787 inch) with the length adjustment screw.



Drilling and countersinking

Drilling and countersinking operations can be done without exchanging the quick-change holder, simply by blocking the length compensation with a locking screw.

The resulting advantages are:

- Alignment offset between drilled hole and thread reduced to a minimum
- No time-consuming re-tooling, with according cost reduction



Tool adaption by means of quick-change adapters, EM series

The quick-change adapters of our EM series have been designed for use in the quick-change tap holders of our KSN and SFM series. The five sizes have been divided into corresponding thread size ranges, and are available in different types. The adaption of the tool is made by means of a quick-change ball clamping system in most quick-change adapters, with a separate adapter being necessary for each shank diameter. Our quick-change adapters are suitable for the production of right-hand and left-hand threads.



Tool adaption by means of quick-change adapters, HE series

The tool adaption is effected by means of quick-change adapters of our HE series. The clamping of the tool is provided by threaded pins. For our adapters type HE 2/IKZZ, we recommend a fastening torque of 11.06 ft lbs / 15 Nm.



Tool adaption by means of collets, type ER (GB)

The tool adaption is effected by means of collets of our ER, or our ER-GB series (with integrated square) acc. DIN ISO 15488 (formerly DIN 6499). This type of clamping helps to achieve very good concentricity and a safe clamping of the tool, especially with high cutting speeds and coolant pressures.



Tool adaption by means of collets, type PGR-GB

The tool adaption is effected by means of collets of type PGR-GB (with integrated square).



7.2 Assembly of sealing disk, collet and tool

Assembly of sealing disk in the sizes 1-5

1. Insert the sealing disk into the clamping nut as shown in the illustration, and push it forward until you can clearly hear it engaging. After that, the sealing disk is flush with the clamping nut.

In **size 0**, you can use clamping nuts with integrated sealing system – a separate sealing disk is not needed then. The clamping nut must be selected in accordance with the clamping diameter used.

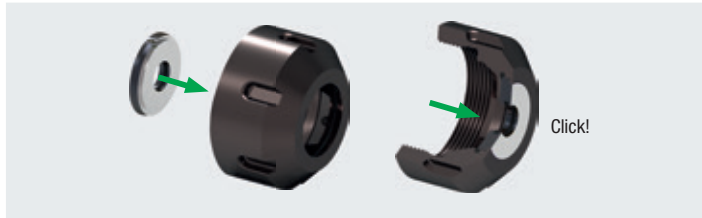

2. Insert the collet into the clamping nut, then tilt it. The groove of the collet must engage in the eccentric ring of the clamping nut at the marked position. Now, tilt the collet in the opposite direction until you clearly hear it engaging.

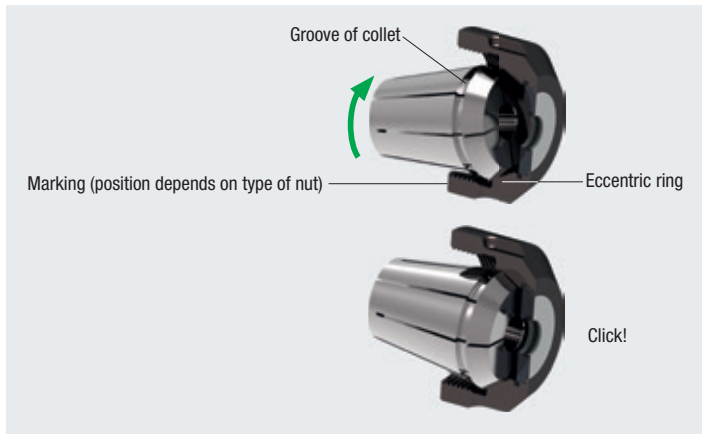

3. Screw the clamping nut with the engaged collet onto the thread of the holder.
Important: Only screw on clamping nuts with correctly engaged collet!



4. Insert tool.

Important: If you use a collet with integrated square, make sure to turn the tool around until it is in a position that allows it to be pushed into the square seat of the collet.

5. Tighten the clamping nut with the wrench.
Observe the rec. torque values in the table.

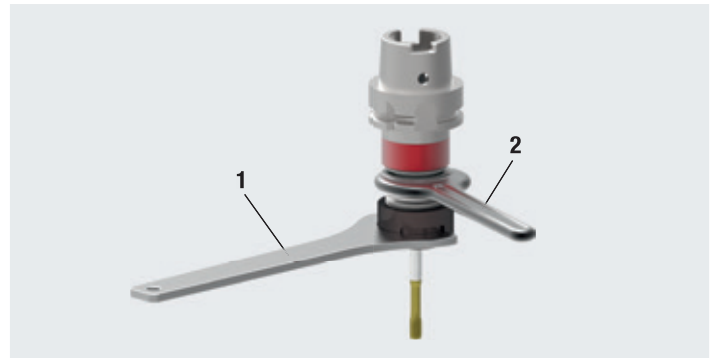

Type	Recommended Tightening Torque	
	ft lbs	Nm
Hi-Q/ERM 8	4	6
Hi-Q/ERM 11	9	12
Hi-Q/ER 11	10	14
Hi-Q/ER 50	221	300
Hi-Q/ERMC 11	9	12
Hi-Q/ERMC 16	18	24
Hi-Q/ERMC 20	21	28
Hi-Q/ERMC 25	24	32
Hi-Q/ERC 11	10	14
Hi-Q/ERC 16	30	40
Hi-Q/ERC 20	24	32
Hi-Q/ERC 25	59	80
Hi-Q/ERC 32	66	90
Hi-Q/ERC 40	133	180
Hi-Q/ERBC 50 AF	221	300

The indicated values apply to collets type ER-GB. The maximum tightening torque must not be more than 25% above the recommended tightening torque. Higher tightening torque may result in the damage of the collet. For the setting of the correct torque, we recommend using a torque wrench, see page 623.

Important: In order to avoid damage to the holder, please counter with open-ended spanner **2** while tightening the clamping nut with wrench **1**. For suitable tool sets, see pages 621 - 622.

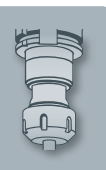

7.3 Overview of hollow taper shanks with flange contact surface (HSK)

DIN 69893-1, ISO 12164-1

Form A

- Standard design for machining centers
- For automatic tool change with gripper and indexing groove
- Central coolant supply by way of coolant tube
- Drive-key slots at the end of the taper
- Bore for data chip (DIN 69873)
- Useable as Form C also, since clamping activation bore is included

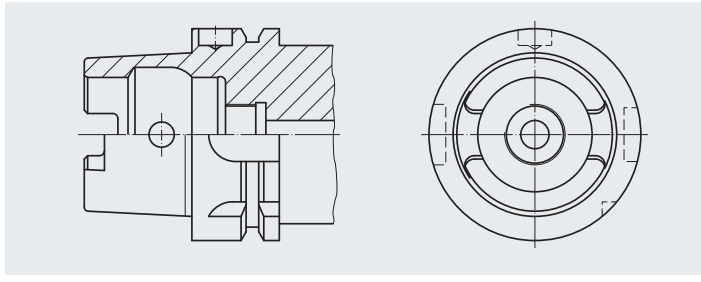

DIN 69893-1, ISO 12164-1

Form C

- For special machines and modular tool systems
- For manual tool change
- Central coolant supply
- Drive-key slots at the end of the taper

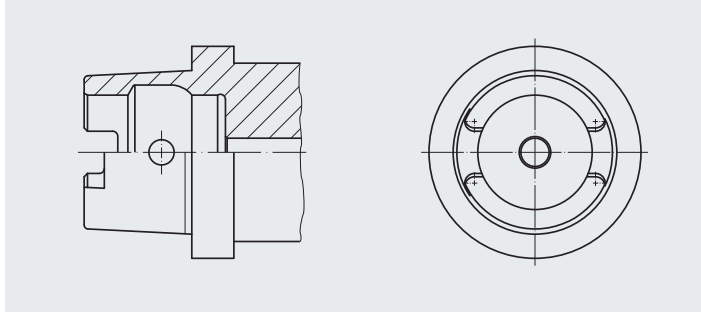

DIN 69893-6

Form F

- For high-speed machining, mostly in woodworking
- With extended flange contact surface for increased radial strength
- For automatic tool change
- Central coolant supply by way of a coolant tube is possible
- Without drive-key slots, rotationally symmetric

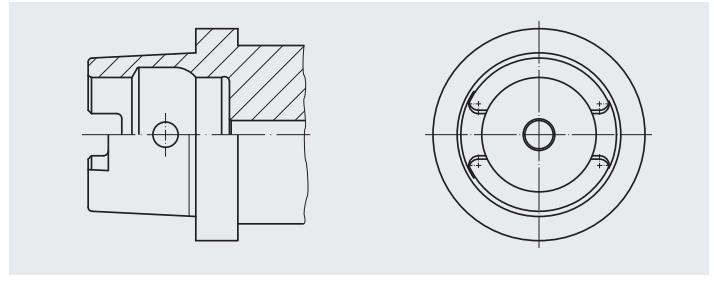

ISO 12164-2

Form T

- For turning and milling machines
- For automatic tool change
- Central coolant supply by way of coolant tube
- Modified drive-key slots
- Bore for data chip (DIN 69873)
- Useable as Form C also, since clamping activation bore is included

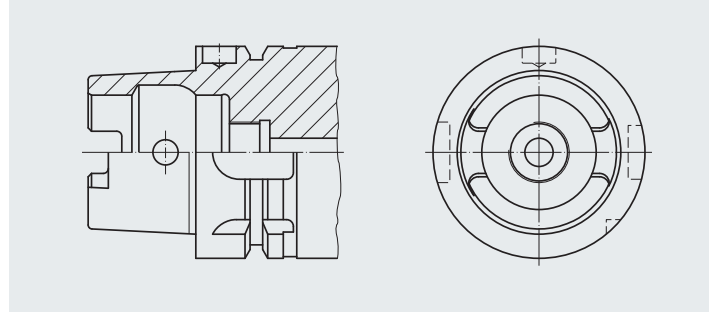
Product
FinderSoft-
synchroSpeed-
synchro

KSN

MQL

SFN

HF

EM

Accessories

Tech. Info



- Product Finder
- Soft-synchro
- Speed-synchro
- KSN
- MQL
- SFM
- HF
- EM
- Accessories
- Tech. Info

7.4 Rigid tapping

Why synchronous thread production with rigid collet holders will not result in optimum tool lives.

When producing a thread on a CNC machine with taps or roll form taps (for simplicity's sake, we will call them threading tools in the following) the speed of the rotation movement of the machine spindle with the speed of the feed axis must be registered, accounted and synchronized. When accounting the threading tool pitch and the cutting speed – giving the feed speed, faults may occur caused by parameters not being considered during the control.

Two main influencing variables are:

1. Influencing factors by the CNC machining center

Computer speed, resolution of the axis detection (linear axis, turning axis, C-axis), mechanical condition of the machine.

2. Influencing factors by the threading tool

- a) Tolerances of the thread pitch acc. to DIN EN 22857
- b) Change of thread pitch and length of the threading tool
when $t_{\text{Work}} \neq t_{\text{Measurement}}$

1. Influencing factors by the CNC machining center

Regarding the formfitting between tool and workpiece, the cutting and forming of threads with synchronous spindles requires permanent μ -exact control and adjusting of the feed axis movement in relation to the rotation movement of the tool spindle. Thus the thread production differs from other known kinds of machining eg drilling, reaming or milling. These processings only require an exact linear movement of the control for positioning purposes, as these tools are not connected formfitting with the workpiece. Consequently, the main emphasis of machine manufacturers is on the control of the linear axis. In practice today simply rotary pick-ups with 256 impulses per spindle rotation (360°) are used to control the rotation axis. This corresponds to an angle and so a control gap of 1.4° per impulse.

- Axial forces during thread machining arise caused by control faults or control inaccuracies.

Example:

Tap M10
Thread pitch 1.5 mm
Possible uncontrolled spindle rotation 1.4°

- Possible axial position fault of about $5.8 \mu\text{m}$ between threading tool specified position and machine spindle real position.

Graph machine spindle turning position fault / axial pitch fault (depends on thread pitch)

Effect of machine turning movement fault on the tool

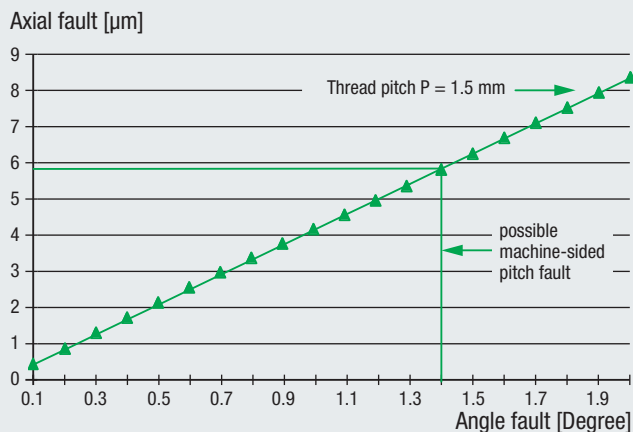

Additionally, the computer speed of modern CNC machining centers is not sufficient to handle a higher number of impulses of the rotary pick-up in the range of $n = 0$ up to the max. spindle speed and to adjust the axis to be synchronized. The example of a CNC machining center with 256 impulses per spindle rotation shows that the axial force working on the tool flanks, increases with growing cutting speed.

The following graphs show that the axial force for forming an M10 thread with 500 rpm (about 51.5 SFM / 15.7 m/min) is at about 427 lbf (1900 N); with an increase of the speed to 2000 rpm (about 208 SFM / 62.8 m/min) at over 562 lbf (2500 N). This clearly shows that the arising axial force, caused by the synchronisation fault, depends on the speed.

Speed 500 rpm Roll form tap M10 in material 1045

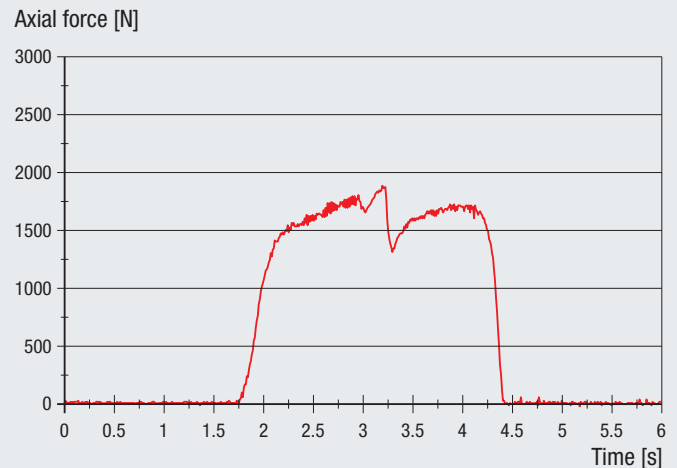

Speed 2000 rpm Roll form tap M10 in material 1045

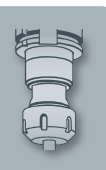
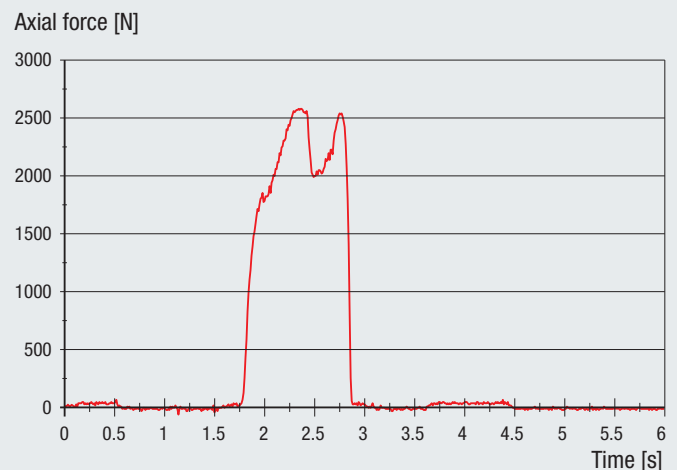

7.4 Rigid tapping

2. Influencing factors by the threading tool

a) Tolerances of the thread pitch

For threading tools the European standard DIN EN 22857 defines the dimensions and tolerances for ground threads.

For the tool tolerance the standard allows a smallest deviation of $\pm 8 \mu\text{m}$ referred to a defined number of threads.

Example:

- Tap M10
- Thread pitch 1.5 mm
- Check length 7 threads
- Allowed pitch tolerance $\pm 8 \mu\text{m}$

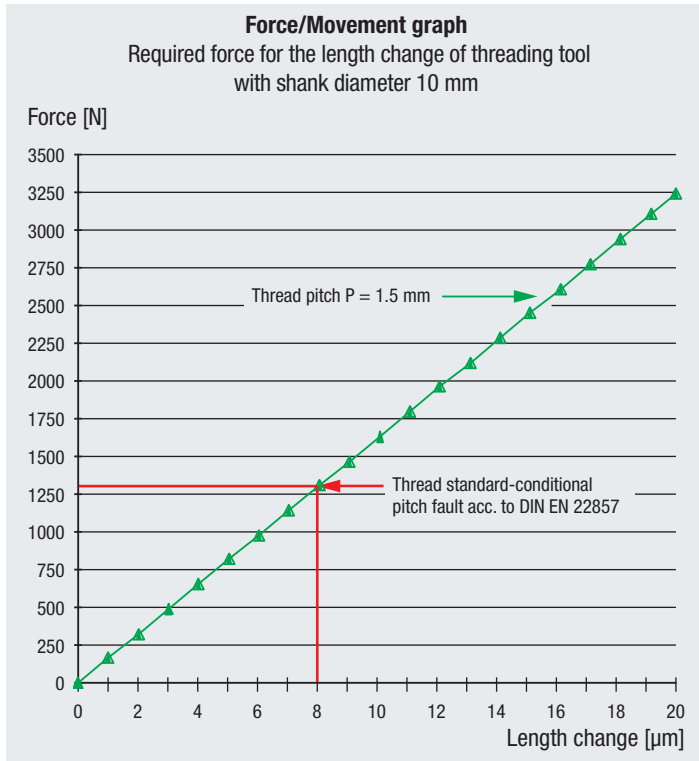

b) Change of thread pitch and length of the threading tool

when $t_{\text{Work}} \neq t_{\text{Measurement}}$

Each tool temperature – differing from the measuring temperature 20°C – causes a change in length. For an M10 tap with 100 mm length the temperature change from 20°C to e.g. 40°C causes a length change of $32 \mu\text{m}$.

Considering a check length of 7 threads acc. to standard DIN EN 22857 the following **example** results:

- Tap M10
- Thread pitch 1.5 mm
- Tap length 100 mm
- Check length 7 threads = 10.5
- Axial growth of the tool and thread pitch of $3.4 \mu\text{m}$

Temperature change development of a threading tool M10
Length 100 mm, temperature change 20°C , length change $32 \mu\text{m}$

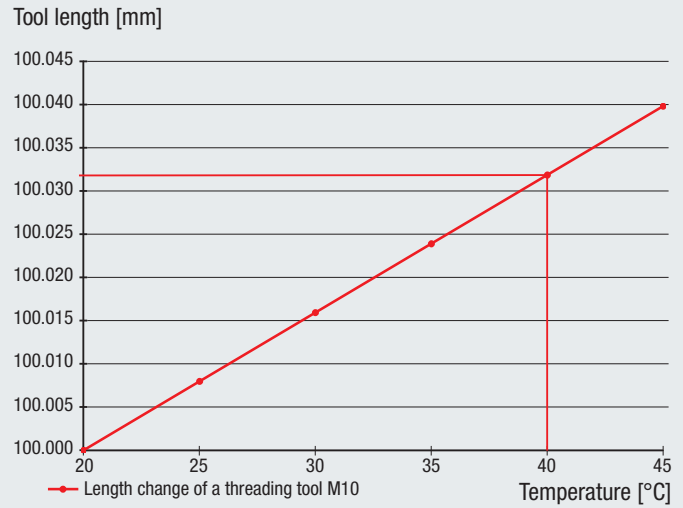

Referred to a check length of 7 threads acc. to DIN EN 22857 and a pitch of 1.5 mm the **axial length** would **change by $3.4 \mu\text{m}$** .

The proof of a change in temperature of the threading tool can be given by measuring the cutting face being heaviest used during the thread production. The following graph shows the temperature of the cutting face for a threading tool M10 with various cutting speeds. Material used is 1045, coolant-lubricant is 5% emulsion.

Temperature progressing on the tool tooth face (M10), emulsion as coolant-lubricant

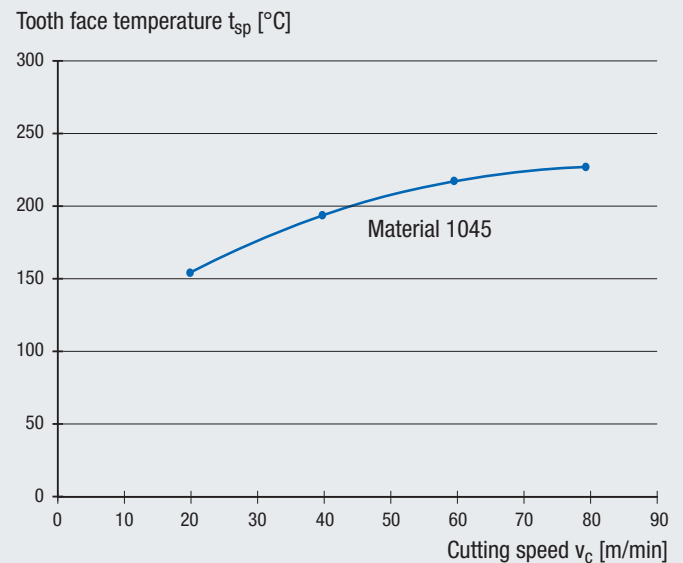

- Product Finder
- Soft-synchro
- Speed-synchro
- KSN
- MQL
- SFM
- HF
- EM
- Accessories
- Tech. Info**



7.4 Rigid tapping

Summary

To realize the total effect of the individual influencing factors mentioned before on the axial force component of the thread producing process, the shown possible position faults, length changes resp. the forces causing length changes must be combined.

The following graph shows:

- With an addition of possible axial faults caused by machine pitch tolerance or temperature influencing factors a position fault between specified position of the tap and real position of the machine spindle of more than 17 µm may arise
- **This position fault results in an axial force of about 2800 N** in the shown example with a threading tool M10.
- This force is taken up by the flanks of the tool resulting in increasing flank friction and increased tool wear.

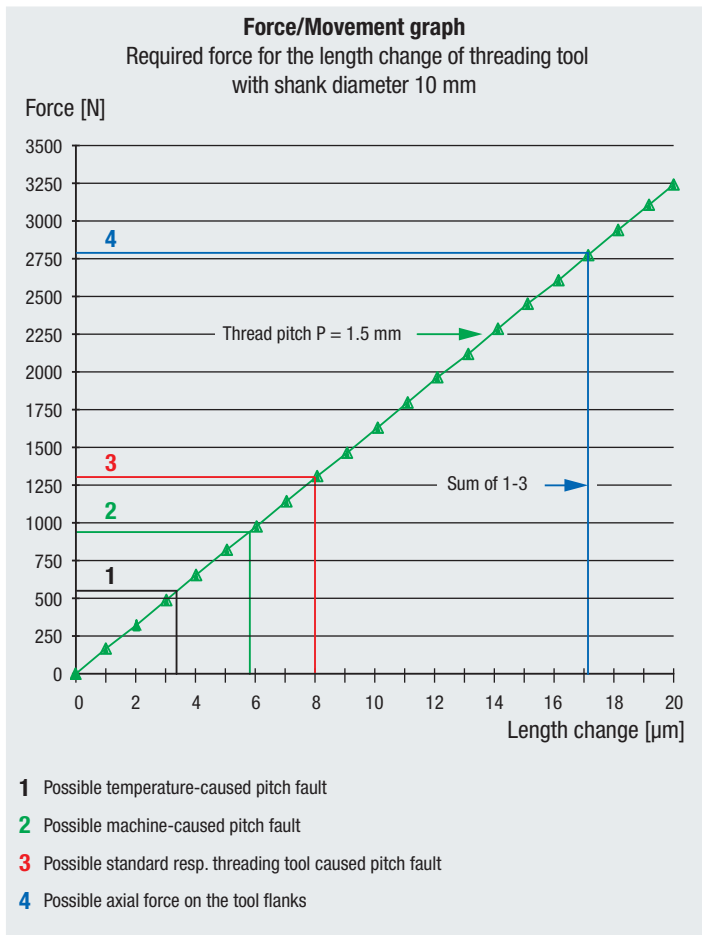

These perhaps theoretical reflections of the processes during production of a thread can be proven in practice.

As an **example** an M10 thread with three different tool holders is formed in material 1045. The axial forces were recorded at two speeds which were 500 rpm = 51.5 SFM (15.7 m/min) and 2000 rpm = 206 SFM (62.8 m/min). The following collet adaptions have been tested:

- Rigid synchronous collet adaption
- EMUGE collet adaption Softsynchro® size 1 with minimum length compensation on compression and tension
- Synchronous collet adaption of a competitor with minimum length compensation with axial damping

With all tested collet adaptions a collet type ER20-GB with integrated square was used.

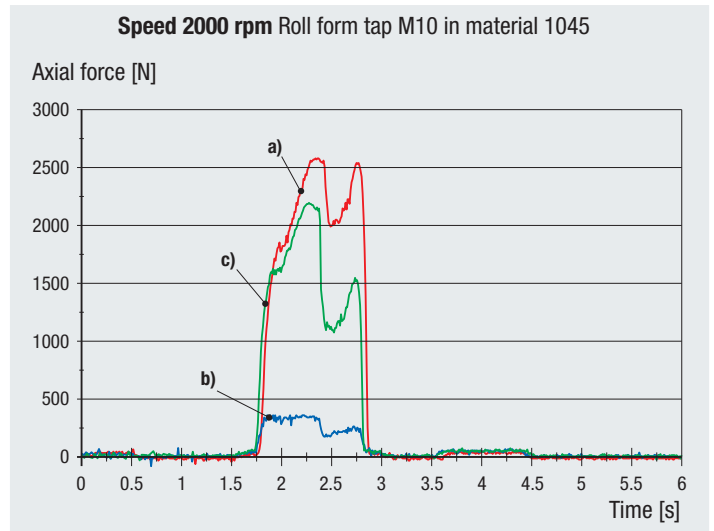
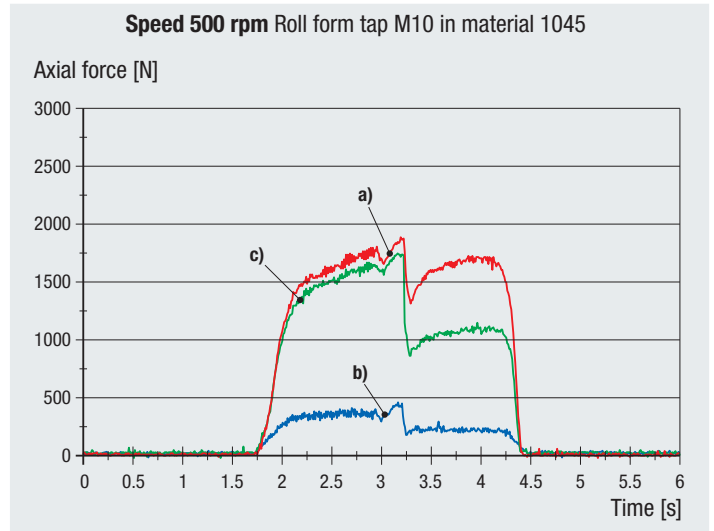

The following results were verified in these tests:

- Axial forces increase with the raise of speed
- The forces which come into play in the cold forming of threads are considerably higher with a rigid collet holder than with an EMUGE collet holder type Softsynchro®
- The competition collet holder can absorb the upcoming forces only lightly, in comparison with the rigid collet holder

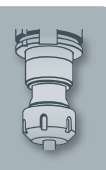

7.4 Rigid tapping

What is the reason for the outstanding axial force performance of the EMUGE Softsynchro® tap holders with minimum length compensation?

Important feature is the patented designed separation of torque and axial force transmission.

Further design features of the EMUGE Softsynchro® tap holders are:

- Clearance-free C-axes by formfitting torque transmission over steel balls
- Smooth response of the pre-stressed minimum length compensation after exceeding the constructive defined guiding force by nearly loss-free roll friction of the torque transmission balls in their ball tracks
- Minimum length compensation and axial force transmission over pre-stressed elastomer springs
- Elastomer springs preventing the tool cutting edge from bracing by their damping characteristics

If the separation of torque and axial force transmission is disregarded, an axial fault is caused immediately when starting the thread cutting process, see example of the competition collet holder. Consequently, the axial force immediately increases heavily, see graphs on the preceding page. This is avoided by the practical-related design of the Softsynchro®.

For machine tools not providing the feature of synchronous thread machining it is necessary to use a larger length compensation than the minimum length compensation of the Softsynchro® holders.

EMUGE supplies length compensation holders KSN/HD with collet adaption and internal coolant supply. The advantages of clamping the tool over collets are combined with those of a classic length compensation holder.

7.5 Tool monitoring system DDU4

The new tool monitoring system DDU4 is a newly developed system, consequently following upon the already successful ICS and TTS systems. In addition to the current torque indication, you can now also monitor the axial force, contact-free, in real-time. With the option to set fixed response and breakage limits in N or Nm in combination with the ARTIS process monitoring systems, the following recognition features become possible in addition to the standard functions:

- Tool wear
- Missing tool
- Defective thread holes
- Different thread depths
- Material contact
- Tool breakage

Digital signal processing made it possible also to enlarge the measuring range for torque and axial force. These measuring ranges are each subdivided into three steps, each of which can be called off externally.

The DDU4 system is available in two versions:

1. Basic solution: DDU4 as "stand-alone system"

This is an economically efficient upgrading system for tool monitoring. For both torque and axial force, two fixed limit values in Nm or kN can be set. An integrated LCD display will visualize the curve progress, and serve for entering the requested values. Alarm signals are emitted by one switch each for torque and axial force.

In combination with the process monitoring system CTM, the DDU4 system will serve as a 2-channel measuring converter.



2. DDU4 in combination with CTM

In combination with the CTM process monitoring system, the DDU4 system will offer you as additional performance characteristics the recognition of:

- Tool wear
- Defective thread holes
- Material contact
- Chip clogging
- Missing tool
- Different thread depths
- Tool breakage
- Evaluation for statistical purposes



- Product Finder
- Softsynchro
- Speedsynchro
- KSN
- MQL
- SFM
- HF
- EM
- Accessories
- Tech. Info

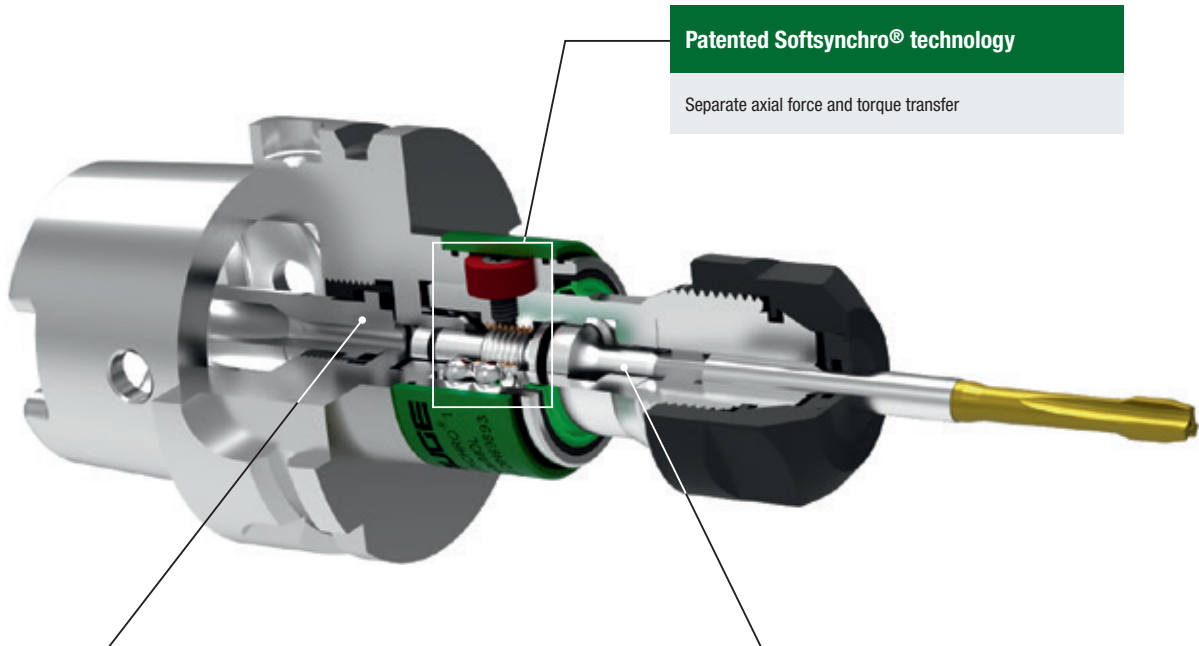

7.6 Collet holders Softsynchro® Modular

Softsynchro® Modular/MQL



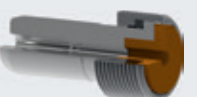

Patented Softsynchro® technology
Separate axial force and torque transfer

MQL transfer element

-  Coolant tube HSK-A for 1-channel MQL system
-  Coolant tube HSK-A for 2-channel MQL system
-  Adapter for application of HSK-A as HSK-C for 1-channel MQL system

Length adjustment screw

-  Internal taper, for tool shank with male center 90°
-  External taper, for tool shank with female center 60°

Completion of the Softsynchro® series

Because of the requirement of various users from the automotive industry, the successful Softsynchro® series has been expanded by the version Softsynchro® Modular.

The **modularity** of the collet holders consists of **variable exchangeable transfer elements** and **length adjustment screws**.

A wire thread insert allows a force-dependent minimal axial movement of the length adjustment screw. The axial force between length adjustment screw and threading tool – arising during tightening the clamping nut to the required tightening torque – is minimized by this design.

Modern machine tools stand out with a high rotation acceleration of the spindle. The wire thread insert secures the length adjustment screw additionally against twisting during switching of the spindle rotation direction.

The new version Softsynchro® Modular is available for minimum quantity lubrication (MQL) as **Softsynchro® Modular/MQL** and for internal coolant supply (IKZ) as **Softsynchro® Modular/IKZ**.

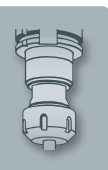

7.6 Collet holders Softsynchro® Modular

Softsynchro® Modular/IKZ

Patented Softsynchro® technology

Separate axial force and torque transfer

MQL transfer element

Standard coolant tube HSK-A
acc. DIN 69895

Length adjustment screw

For tool shank with male
or female center

The Softsynchro® Modular offers the same advantages of the minimum length compensation as in a synchronous thread machining. For more information on this topic, see **7.4 Rigid Tapping**.

For an instruction on how to assemble the sealing disk, collet and tool as well as correct torques, please refer to chapter **7.2 Assembly of sealing disk, collet and tool**.

Product
FinderSoft-
synchroSpeed-
synchro

KSN

MQL

SFM

HF

EM

Accessories

Tech. Info



7.7 Minimum-quantity lubrication (MQL)

General information

By minimum-quantity lubrication, we mean the cooling of machining processes with very small amounts of coolant-lubricant. In this, it is important that the coolant-lubricant is conveyed directly to the point of contact between tool and workpiece in order to reduce the generation of heat by friction there. Even with repeated tool changes, the coolant-lubricant must be dosed and transported to the tool with the highest possible degree of process safety. The term minimum-quantity lubrication applies when a quantity of 5 to 50 ml/h of the MQL medium is consumed, air is used as a carrier medium. This technique is a redeveloped version of wet machining where the machining area is flooded with coolant-lubricant. Another technique is dry machining which is done completely without coolant-lubricant.

Different MQL systems

Generally, we make a distinction between **external** and **internal** MQL systems:

- With **external** supply systems, the aerosol containing the oil is sprayed onto the point of machining through a jet installed in the machining space of the machine tool. No special holders or tools are needed.
- With **internal** supply systems, the MQL medium is conveyed through a rotary transmission, the work spindle, the tool holder and the tool itself, directly to the cutting edge of the tool. For such systems, special holders with a straight feed-through of the MQL medium for perfect flow are necessary. What is also needed are tools specially designed for MQL, with a transfer chamfer adjusted to the holder and with optimized coolant-lubricant outlets.

With the **internal** supply systems, we make a further distinction between **1-channel MQL** systems and **2-channel MQL** systems:

- In a **1-channel MQL** system, the aerosol is generated in the MQL device before it enters into the machine spindle, and is then conducted through the work spindle and the clamping system to the point where it is needed.
- In a **2-channel MQL** system, oil and air are conducted through the spindle separately, the mixing of the two media is done only at the point where they enter the tool holder.

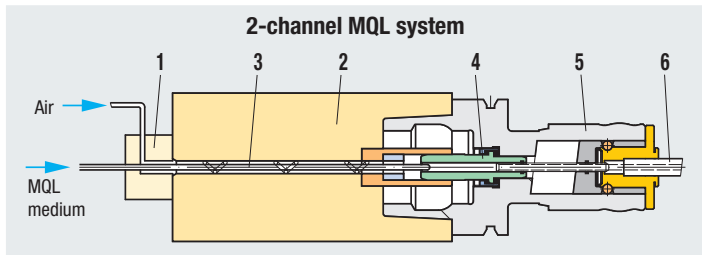
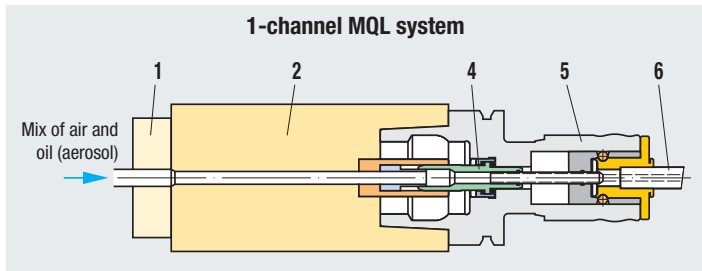

- | | |
|-----------------------|-----------------|
| 1 Rotary transmission | 4 Transfer unit |
| 2 Work spindle | 5 Tool holder |
| 3 MQL medium lance | 6 Tool |

The tool holders

Tool holders for minimum-quantity lubrication must not only provide safe clamping for the tool, but must also permit unhindered, loss-free and free-flow through-feed of the aerosol. In 2-channel MQL systems, it is also necessary to produce the mix of oil and air during the transfer from the spindle to the shank. These challenges have led to the design of special quick-change tap holder and collet holders which meet the requirements of the different MQL systems. Additionally, several company standards and the standard E DIN 69090 were established for a clear specification of the point of transfer from spindle to tool holder. Our EMUGE holders, needless to say, meet all the requirements of these standards, too.

In order to avoid dead spaces and oil clogs, EMUGE offers also the suitable tools for minimum-quantity lubrication. With their detailed adjustment to the holders, an optimized transfer from tool holder to tool can be guaranteed.

The following tool holders are available:

1. KSN/MQL

These quick-change tap holders are equipped with length compensation on tension and compression, with the EMUGE patented pressure-point mechanism and the proven front release. In addition, a spring-loaded tube guarantees a disturbance-free feed-through of the aerosol. This same tube also provides the permanent transfer of the aerosol from the tool holder to the tool. As a complement, EMUGE offers adapters type EM/MQL which provide a sealing surface between quick-change tap holder and quick-change adapter. This sealing surface is especially helpful in the machining of cast materials and in "overhead" machining situations.

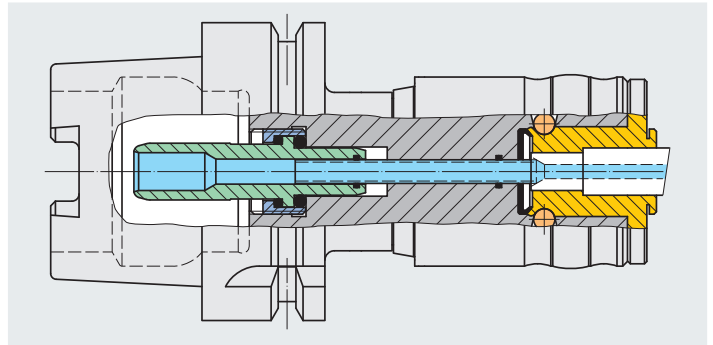

2. Softsynchro®/MQL

These collet holders are equipped with the well-known minimal length compensation with separate transfer of torque and axial force, see also chapter 7.4 **Rigid tapping**. Again, there is an optimized feed-through for perfect flow ensured by a spring-loaded tube. This tube is always in firm contact with the end of the tool shank due to the spring pressure, and guarantees loss-free transfer.

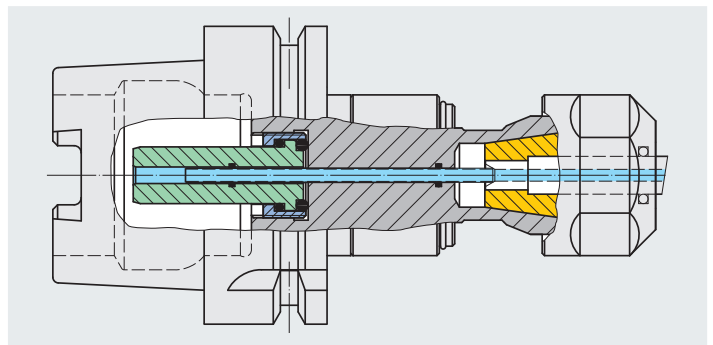

7.8 Collet holders Speedsynchro® Modular

Application range

Speedsynchro® Modular are designed for use on CNC-controlled machine tools.

Functionality

The Speedsynchro® Modular uses an integrated transmission gearing with a transmission ratio of 1 : 4.412 and combines it with the patented Softsynchro® minimal length compensation function.

The transmission gearing allows

- To work in the unproblematic and relatively low synchronous spindle speed range (< 1500 rpm) of the machine tool
- To achieve high cutting speeds of the threading tool due to a multiplication of the spindle speed

General specifications

• Higher cutting speeds

In a synchronous thread production machine spindles do not achieve the programmed rotational speeds above a certain spindle speed. The transmission gearing of the Speedsynchro® Modular keeps up with the programmed speeds.

• Longer tool life

The patented minimal length compensation function reduces the axial force on the tap.

• Reduction of energy consumption

Thanks to the transmission gearing the rotational speed of the machine spindle is reduced which results in energy savings of more than 90% compared to synchronous thread machining.

• Reduced installation costs

Lower energy consumption due to the use of minimum quantity lubrication (MQL).

- Modular MQL tubes

Conversion from 1-channel to 2-channel MQL-systems.

- Modular length adjustment screws

Adaption of length adjustment screws to threading tools with male or female center.

Technical characteristics

- Cutting range: M1 - M8
- Collet: ER16
- Transmission ratio: 1 : 4.412
- Max. spindle speed: 2000 rpm
- Max. tool speed: 8824 rpm
- Internal coolant supply
- MQL for 1-channel or 2-channel systems

Advantages of the Speedsynchro® Modular

- Simple programming as synchronous cycle with feed program adapted to the transmission ratio
- Evaluation of time benefit of the Speedsynchro® Modular / synchronous cycle by a "simulation" without Speedsynchro® Modular and tool
- Accurate thread depths – no variations in thread depths associated with conventional tapping attachments since the Speedsynchro® Modular in contrast to tapping attachments does not reverse the sense of rotation
- The reversal of the threading tool is done by the machine drive spindle:
 - No switching components in the Speedsynchro® Modular
 - Low wear and longer maintenance intervals
 - Maintenance independent of number of threads produced
- Patented constructive independent transfer of the machining torque in the production of threads
- Mechanically independent compensation of the axial forces at the threading tool flanks caused by synchronization faults
- Minimum length compensation ± 0.5 mm
- Spring-loaded bearing of the length adjustment screw for compensation of the occurring axial force between length adjustment screw and threading tool when tightening the clamping nut
- Self-locking of the length adjustment screw against unwanted length displacement caused by rotation acceleration during reversal of rotation direction of the machine spindle

Thread production cycle with the Speedsynchro® Modular

The Speedsynchro® Modular is changed into the machine by means of the tool exchanging device, the stop fixture bolt engages in the stop block, the locking device is released and the Speedsynchro® Modular is ready for operation.

Some programming references

The transmission ratio of the Speedsynchro® Modular is 1:4.412 which results in the following programming guidelines:

- Feed f

$$f = P \times 4.412 \quad [\text{mm/rev. resp. inch/rev.}]$$

- Rotational speed n of machine spindle for the desired tool speed

$$n_{\text{MSP}} = n_{\text{TOOL}} / 4.412 \quad [\text{rpm}]$$

P = Pitch of threading tool [mm resp. inch]

n_{MSP} = Rotational speed of machine spindle [rpm]

n_{TOOL} = Rotational speed of threading tool [rpm]

Example thread M6 / pitch P = 1 mm:

- Desired rotational speed of threading tool:
 $n_{\text{TOOL}} = 3000$ rpm
- Required rotational speed of machine spindle:
 $n_{\text{MSP}} = 3000 \text{ rpm} / 4.412 = 680$ rpm
- Required feed:
 $f = 1 \times 4.412 \text{ mm/rev.} = 4.412 \text{ mm/rev.}$

Service

In case spare parts need to be exchanged, EMUGE offers you a repair service that includes e.g. competent repair and maintenance, a professional pressure check and function control with full guarantee.

More information regarding
Speedsynchro® Modular at

www.speedsynchro.com

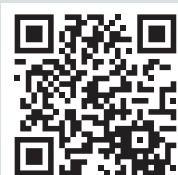

7.8 Collet holders Speedsynchro® Modular

Technical design of the stop fixture for the Speedsynchro® Modular

For the use of the Speedsynchro® Modular, a stop fixture is needed for the following functions:

- Supporting the torque caused by the operation of the Speedsynchro® Modular
- Correct definition of the position between machine spindle and stop fixture whenever automatic tool exchange devices are used

The stop fixture is normally fitted individually to the customer's machine before shipping of the attachment.

Specifications of the stop fixture

Address:

.....
.....
.....

Machine manufacturer / designation:

.....

Locking block available on machine?

Yes No

Shank type and size:

.....

Spindle designation with connecting dimensions for stop fixture available?

Yes (please enclose a copy)

No, dimensions: A: B:

E: W:

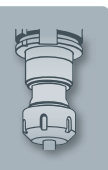
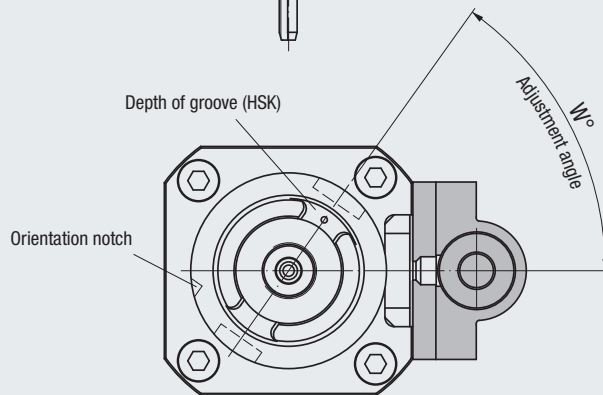
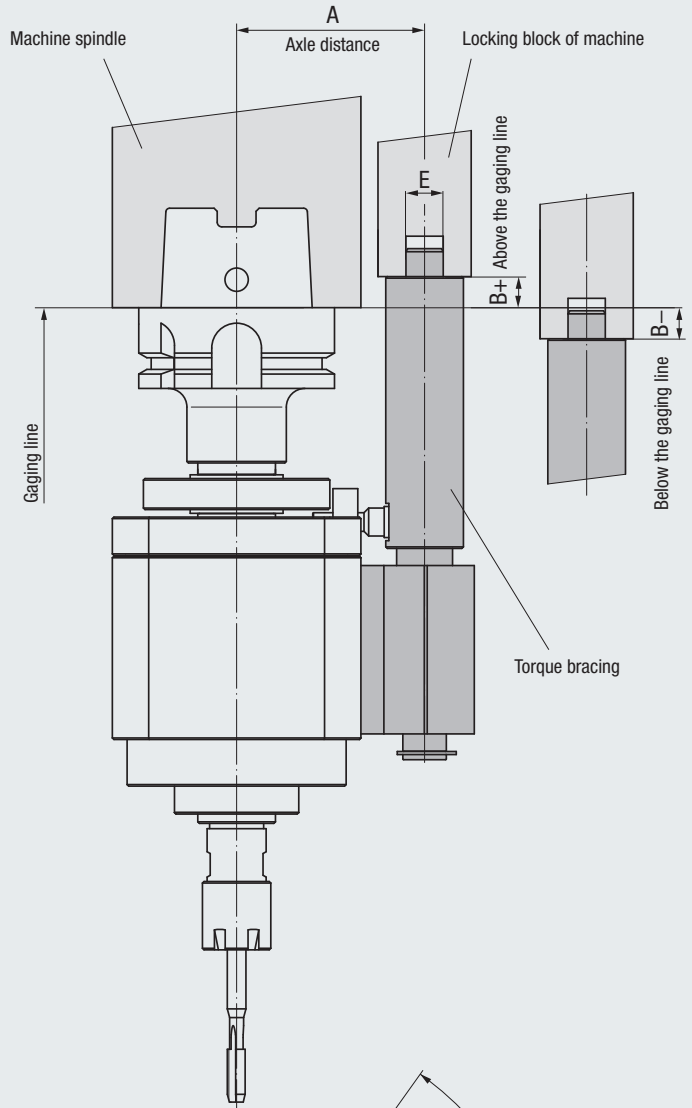

7.9 Adjusting the overload clutch of quick-change tap holders type HF

Adjusting the torque of the overload clutch

The torque to be set depends, among other things, on the type of machining and on the workpiece material to be machined. If the exact torque is not known, we recommend setting a low value first, and approaching the correct torque value step by step.

Attention:

The adjustment must not be carried out while the machine spindle rotates!

Required tools:

- Hexagon socket wrench with pin, width across flats 10 mm
- Depth measurement device or caliper gage with depth measurement

1. Clamp the quick-change tap holder in the machine spindle.

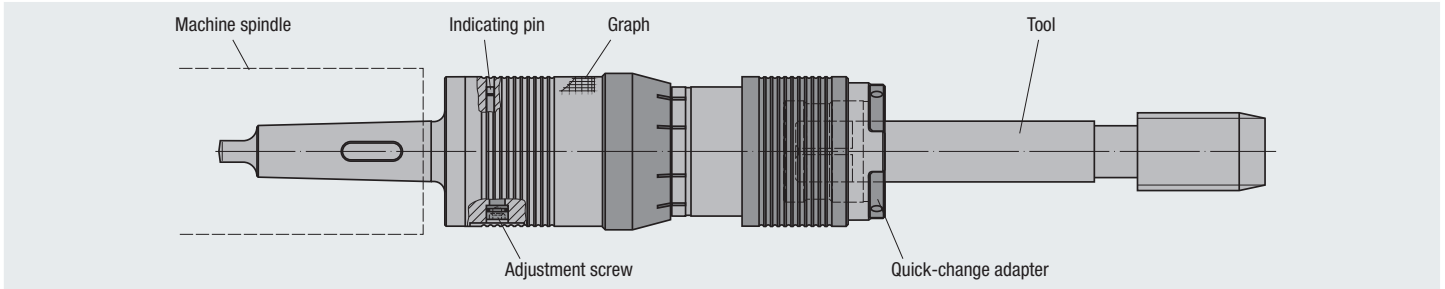

2. For torque adjustment, the marking rings must coincide.

If this is not the case, proceed as follows:

- Put machine into operation
- Let the tool start the cutting process
- Stop machine

Attention:

Repeat this until the marking lines coincide!

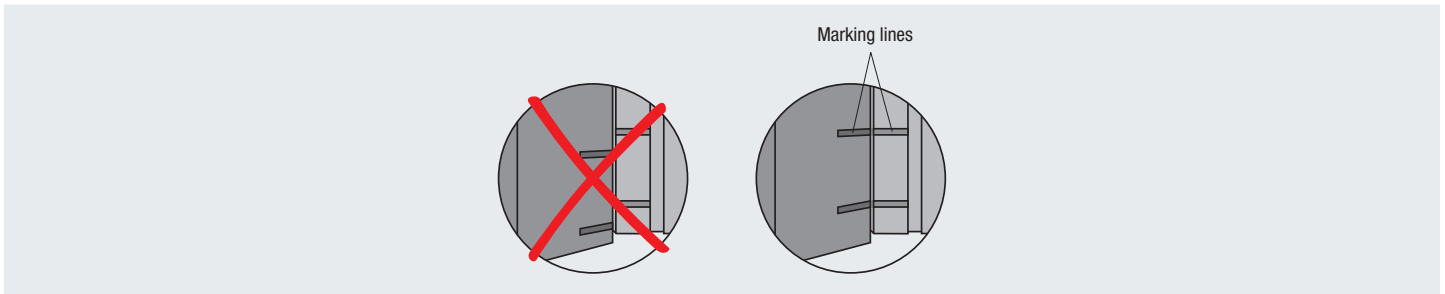

3. Adjust torque by turning adjustment screw.

Attention:

Do not use any extension for adjusting the torque!

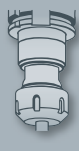
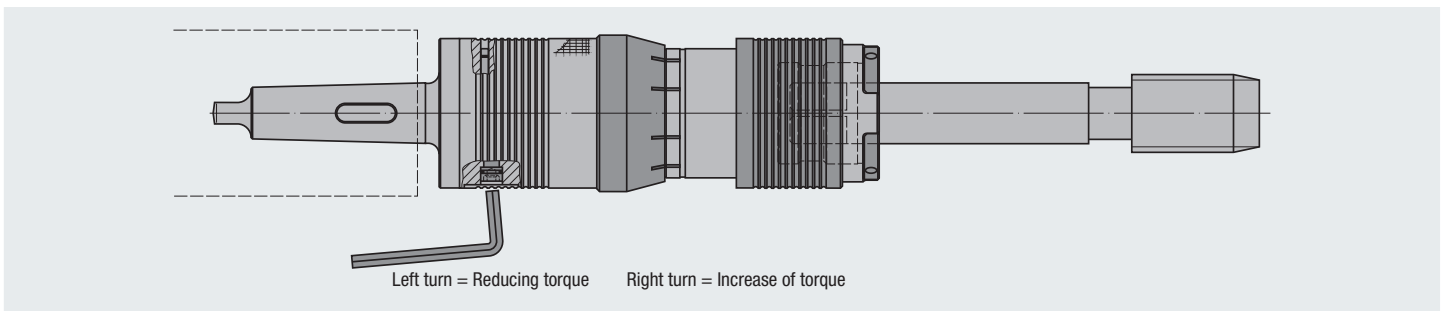

- Product Finder
- Soft-synchro
- Speed-synchro
- KSN
- MQL
- SFM
- HF
- EM
- Accessories

7.9 Adjusting the overload clutch of quick-change tap holders type HF

4. Check torque by:
- Measuring the position of the indicating pin using the depth measurement device
 - Reading the torque from the graph (the graph is fixed on the quick-change tap holder body)

Example: HF 20, measuring depth 2.7 mm
Torque read from graph: 625 Nm

The max. torque is adjusted if the indicating pin matches with the quick-change tap holder diameter.



Tech. Info

Torque progression

The following graphs are printed onto the quick-change tap holder near the adjustment unit in similar form.

Torque progression for the quick-change tap holder HF 20

Example: Measuring depth 2.2 mm
From graph: 750 Nm adjusted torque

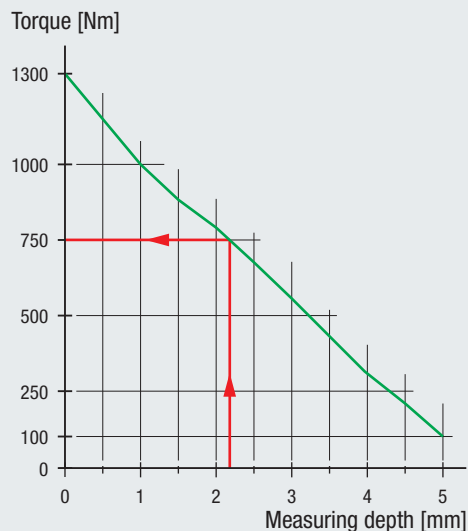

Torque progression for the quick-change tap holder HF 30

Example: Measuring depth 2.75 mm
From graph: 2000 Nm adjusted torque

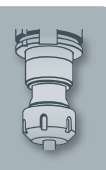
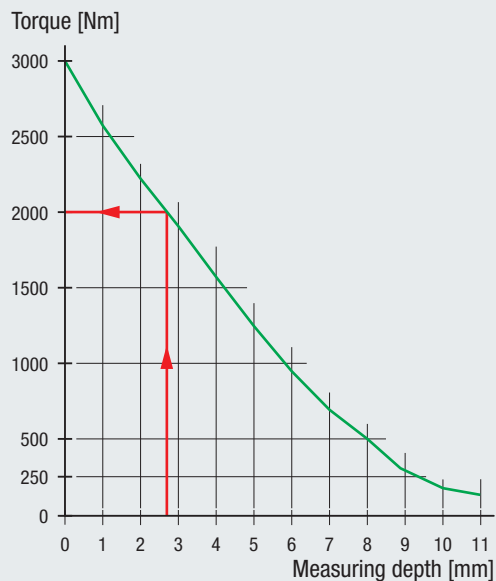

7.10 Cleaning of collet holder and collet type PGR



Clean the PGR interface of the collet holder, e.g. with a taper cleaner or with a clean towel.



Degrease PGR collet, dip in a clean, fat-dissolving and oil-free solvent, e.g. alcohol or cleaning solvent. Dry collet. Only use compressed air if it is clean and oil-free (no preceding maintenance unit).



Set collet into tool holder.

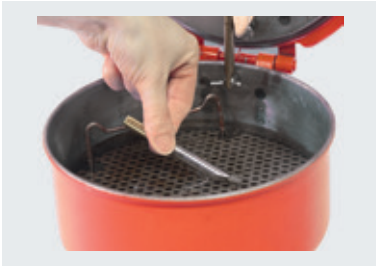

Degrease tool shank by dipping into clean, fat-dissolving and oil-free solvent, e.g. alcohol or cleaning solvent.



Insert tool into the PGR collet. When using a PGR-GB collet with integrated square, the tool must be turned into position in order to be inserted into the square of the collet.

Press in tool by means of PGR clamping unit, or perform length adjustment as described under **7.11 Length adjustment of collet holders type PGR.**

Product Finder

Soft-synchro

Speed-synchro

KSN

MQL

SFM

HF

EM

Accessories

Tech. Info



7.11 Length adjustment of collet holders type PGR

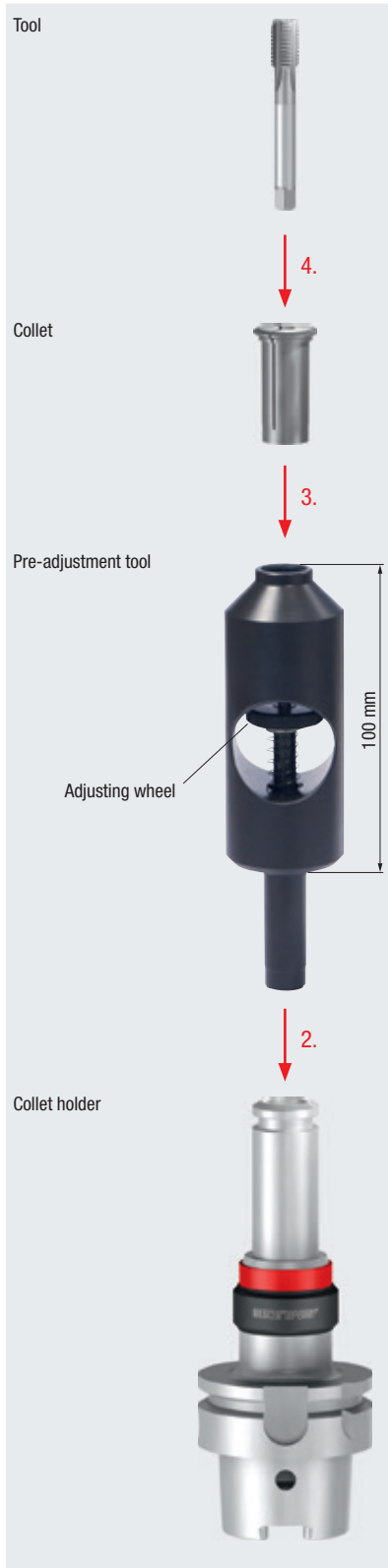

1. Pick up collet holder
2. Insert pre-adjustment tool in the collet holder
3. Insert collet into pre-adjustment tool
4. Insert tool into collet
5. Adjust tool length by turning the adjusting wheel
Attention:
 Observe min./max. clamping length for tool shanks
6. Measure overall length, deduct 100 mm from the overall length measured with pre-adjustment tool
7. Remove pre-adjustment tool
8. Press in tool using the clamping unit

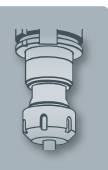



FRANKEN Advanced Milling Technology

FRANKEN has a 100 year history of milling tool development, and today offers a broad range of solid carbide and HSS milling cutters. The FRANKEN program includes end mills, slot drills, die-sinking cutters, shell end mills, gear cutters and highly sophisticated profile cutters that include “Christmas Tree” cutters used in the manufacture of jet engines and power generation turbines.

In addition, FRANKEN has been at the forefront of process and tooling development in the areas of Hard Machining, High Speed Cutting and High Productivity Cutting. Expertise in these areas enabled FRANKEN to develop a complete program for the Mold & Die Industry that includes extra long solid carbide ball and torus end mills, screw-in and shell type cutters with indexable inserts, as well as a complete line of tool holders and tool holding solutions with the SHRINK-MASTER induction shrink-fit system and the powRgrip® tool clamping system.

With this large variety of tool types, the highest production standards and uncompromising precision, the FRANKEN product range will answer the most unyielding quality requirements.



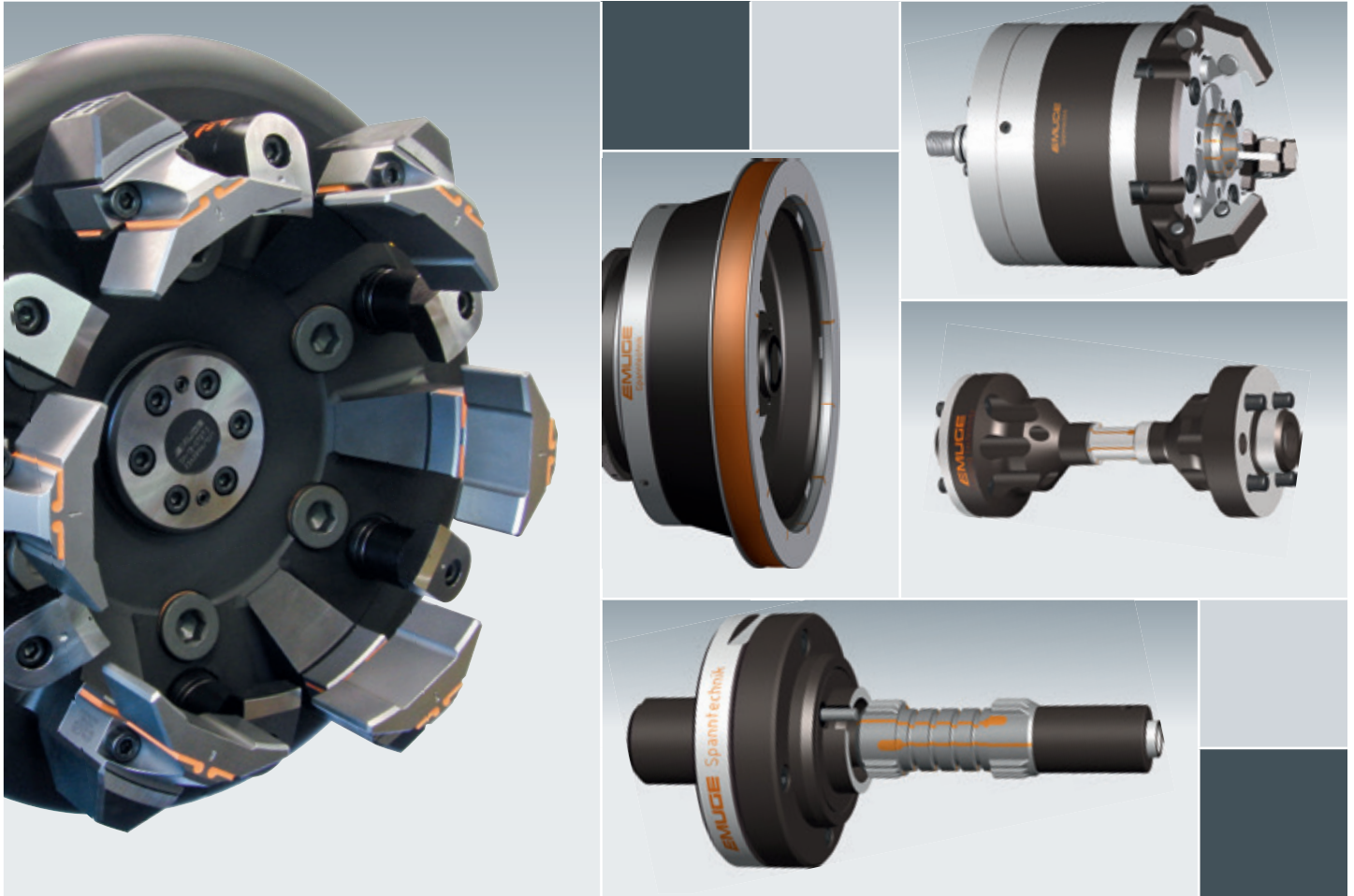

Workpiece Clamping



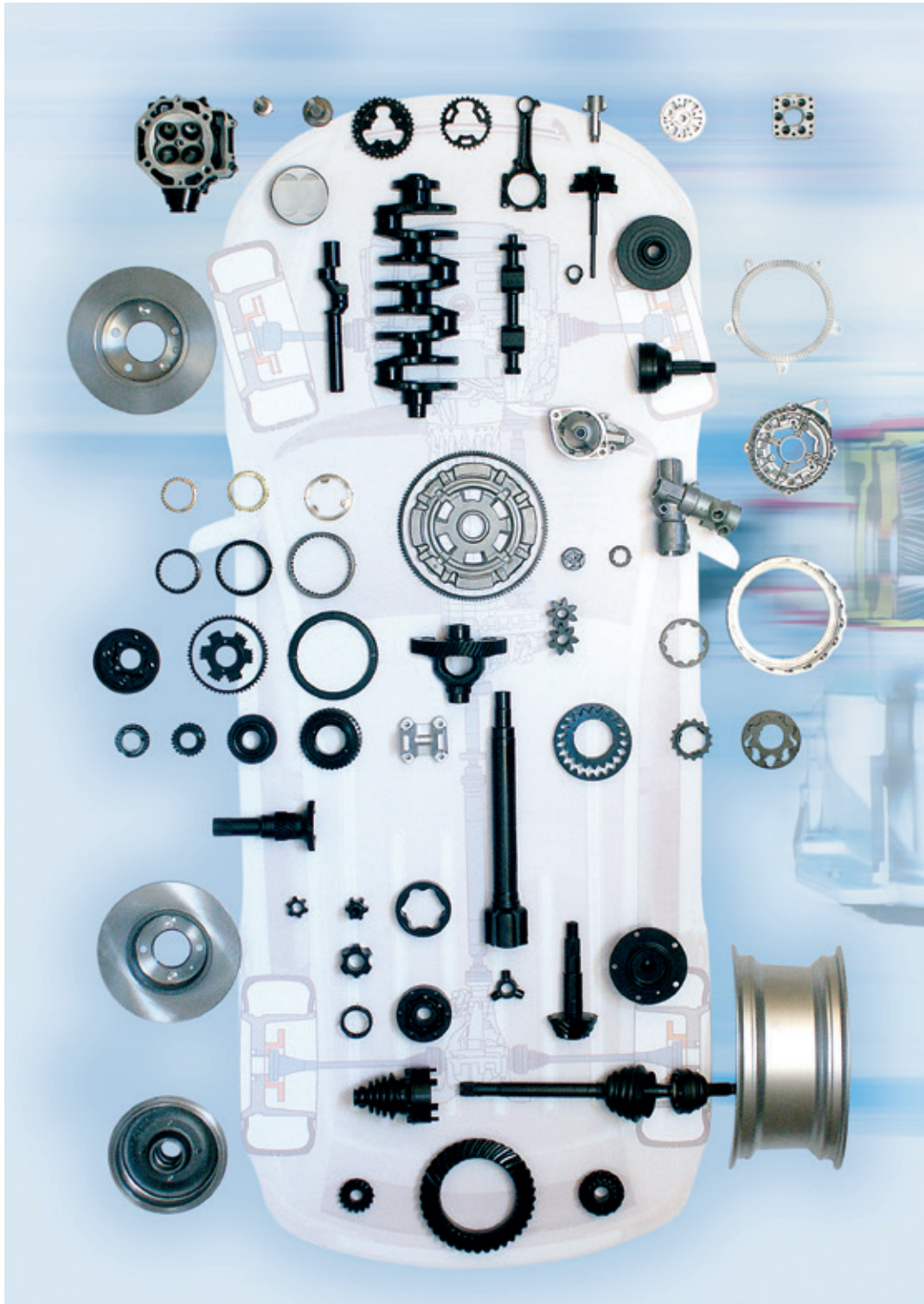

In addition to our collet holders, quick-change holders and tapping attachments, EMUGE also offers **precision clamping tools for workpiece clamping**. The largest part of these clamping tools are designed especially for individual customers' applications, and are, as a consequence, **highly optimized special solutions for specific production processes**. In order to achieve such solutions, it is strictly necessary to analyze all the basic conditions, e.g. machine equipment, precision requirements, details of the production process etc., even in the first planning stage, with a close view to practical work conditions.



System specifications

Workpiece clamping is an essential element of the production process. The largest part of these clamping tools are specially designed for the application case described by the user, which means they are special solutions optimized for the individual production process.

In the development of these clamping tools, all basic conditions like machine equipment, precision requirements and process sequence, must be taken into account with as much regard to practical conditions as possible.

EMUGE, as one of the leading manufacturers of such clamping equipment, uses various clamping principles which we will describe in detail below. The values listed below are only **reference values**.

Features	System				
	SP	SZ	SG	SH	SM
System set-up	mechanical	mechanical	mechanical	hydraulic	mechanical
Achievable concentricity	2 µm	4 µm	4 µm	2 µm	4 µm
Max. expansion in reference to clamping diameter	IT7 (11)	IT13	IT13	IT7	0.1 - 0.6 mm
Clamping ranges, workpiece outside diameter	5 - 400 mm	5 - 400 mm	6 - 300 mm	5 - 300 mm	6 - 300 mm
Clamping ranges, workpiece inside diameter	12 - 400 mm	8 - 400 mm	12 - 300 mm	12 - 300 mm	–
Safety function against over-clamping	yes	yes	yes	partially	yes
Wear protection coating possible	yes	yes	yes	yes	yes

F_R = Radial force

F_A = Axial force

F_E = Application of force

P_E = Application of pressure

Degree of tolerance	Nominal size range in mm											
	≤ 3	> 3 ≤ 6	> 6 ≤ 10	> 10 ≤ 18	> 18 ≤ 30	> 30 ≤ 50	> 50 ≤ 80	> 80 ≤ 120	> 120 ≤ 180	> 180 ≤ 250	> 250 ≤ 315	> 315 ≤ 400
IT7	10	12	15	18	21	25	30	35	40	46	52	57
IT11	60	75	90	110	130	160	190	220	250	290	320	360
IT13	140	180	220	270	330	390	460	540	630	720	810	890



System SP

By applying an axial force the clamping sleeves move in direction of the force and expand radially. On the one hand this eliminates the clearance between clamping sleeve and body, on the other hand between clamping sleeve and workpiece. The workpiece is being clamped.

Depending on the tolerance of the workpiece, on the design of the clamping tool and of the clamping sleeves the system SP achieves concentricities of ≤ 0.002 mm (corresponding to ≤ 0.0001 inch).

Due to this high precision the system SP is not only used to clamp workpieces, it is also used to clamp tools.

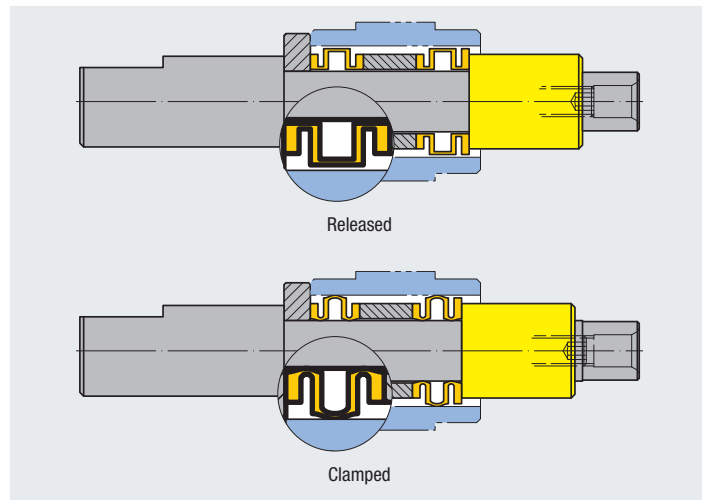

System SZ

If the workpiece to be clamped has only a short clamping base or if the diameter to be clamped has a very large tolerance, system SZ is used.

By applying an axial force a slitted collet is radially expanded by a cone. Simultaneously an axial movement occurs. The workpiece is being clamped.

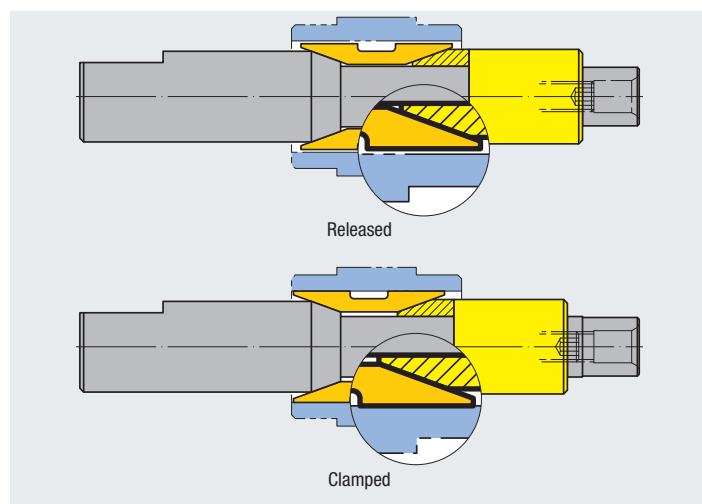

System SG

Depending on the type of design the system SP only allows radial expansion up to tolerance class IT11. To bridge larger tolerances, system SG is used.

This is a slitted clamping bush with a special buttress thread. With this thread the bush is screwed onto the body. By applying an axial force the clamping bush moves in direction of the force. Due to the thread angle there is also a radial expansion. The workpiece is being clamped.

The axial component, which has an effect on the workpiece, increases the transferable torque and the stiffness of the clamping process. Consequently the workpiece is safely clamped even if it is machined with a large depth of cut.

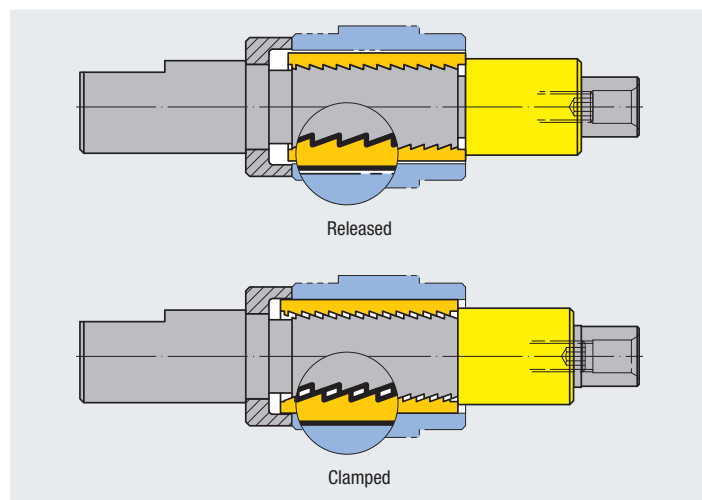

System SH

If there is not enough room for a mechanical clamping system, hydraulic system SH is used. It also allows clamping long, thin-walled workpieces or a number of similar workpieces.

System SH is a closed system filled with hydraulic oil. A force is applied on it with a piston. The hydraulic pressure radially expands the thin-walled clamping zone. The workpiece/the workpieces is/are being clamped.

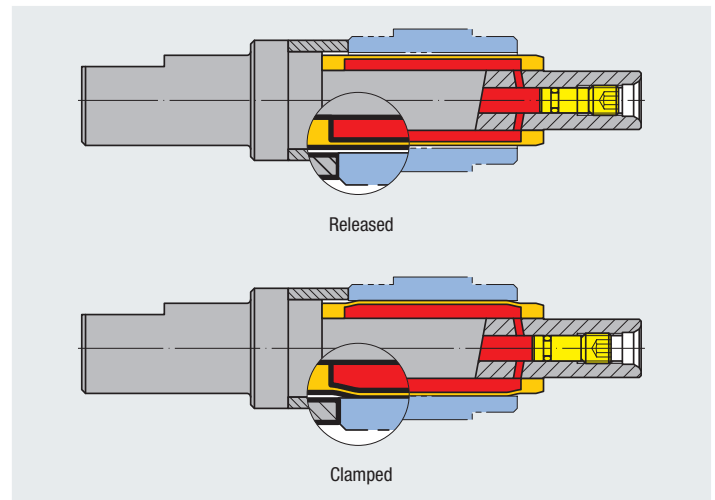

System SM

In order to manufacture high precision gear wheels for example, it is very important that the eccentricity between pitch circle and seating bore is very small.

For this purpose the diaphragm clamping system SM is used. For machining the seating bore it allows clamping of the gear wheel at the pitch circle.

The clamping element is a ring disk with primarily three clamping jaws. If the workpiece is thin-walled the diaphragm can also have four or six clamping jaws. These are either carved out of the diaphragm or they are screwed onto it.

By applying an axial force onto the diaphragm, it bends in direction of the force. The clamping jaws simultaneously move axially and open in radial direction. The gear wheel is being released.

Due to its flexibility the diaphragm returns to its initial position if the axial force is reduced or taken away. The gear wheel is being clamped in axial and radial direction.

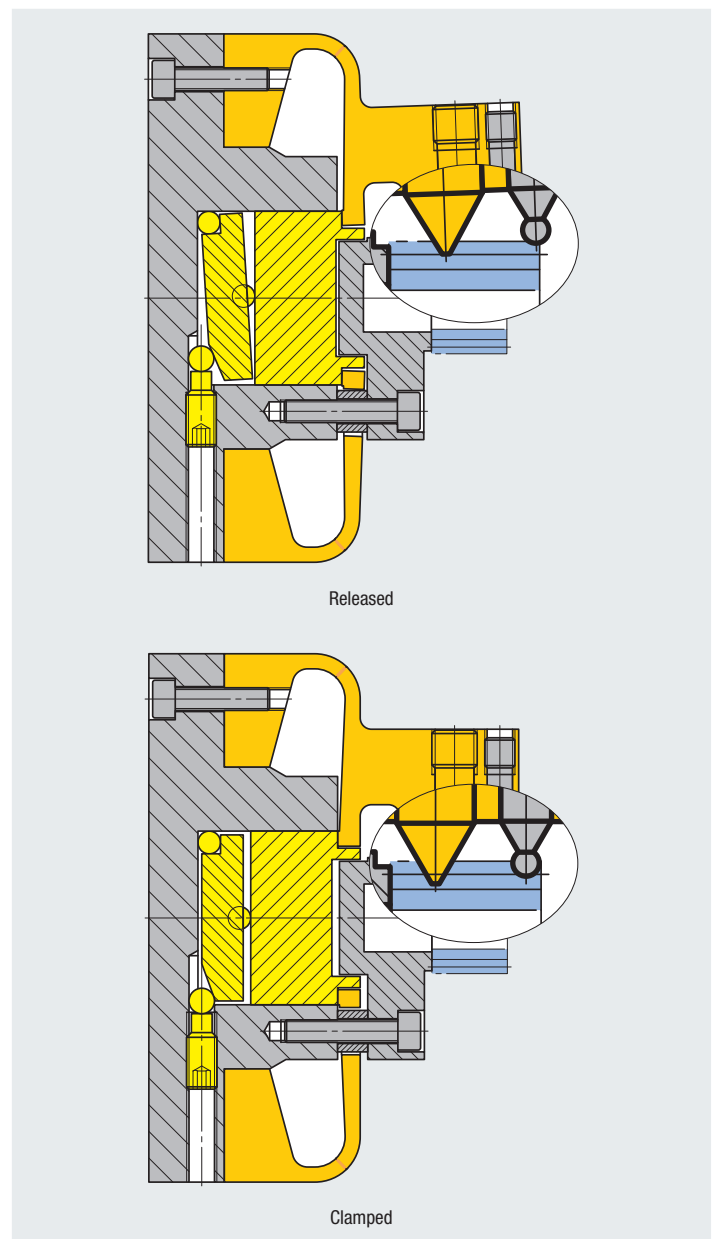

EMUGE Corp. · 1800 Century Drive · West Boylston, MA 01583-2121
 Phone (508)-595-3600 · Fax (508) 595-3650 · Toll Free (800) 323-3013 · www.emuge.com · emuge@emuge.com

Customer Information

Distributor Name:			End User Name:		
Contact Person:			Contact Person:		
City:	State:	Zip:	Street:		
Phone: ()	Fax: ()		City:	State:	Zip:
Customer Inquiry Number:			Phone: ()	Fax: ()	

Tapping Application

Tap Size:	Class of Fit:	<input type="checkbox"/> Through Hole	<input type="checkbox"/> Blind Hole	<input type="checkbox"/> Other:
Material:	Hardness:	Thread Length:	Thread Length:	
Tap Requirement: <input type="checkbox"/> Cutting <input type="checkbox"/> Forming <input type="checkbox"/> Either			Drill Depth:	
Number of Taps Required:		Number of Holes to Tap:		Repeat Job: <input type="checkbox"/> Yes <input type="checkbox"/> No
Machine Tool	Manufacturer/Type:			Direction of Tapping: <input type="checkbox"/> Horizontal <input type="checkbox"/> Vertical
Feed	<input type="checkbox"/> CNC Controlled <input type="checkbox"/> NC Controlled <input type="checkbox"/> Synchronous Spindle <input type="checkbox"/> Cam Followed <input type="checkbox"/> Lead Screw <input type="checkbox"/> Manual			
Tap Holder	<input type="checkbox"/> Tension/Compression <input type="checkbox"/> Rigid (Collet) <input type="checkbox"/> Floating			Tapping Attachment/Type:
Lubrication	<input type="checkbox"/> Thread Cutting Oil <input type="checkbox"/> Emulsion %: <input type="checkbox"/> Dry <input type="checkbox"/> Other:			
Method	<input type="checkbox"/> Circulation <input type="checkbox"/> Brush <input type="checkbox"/> Mist <input type="checkbox"/> Thru Tap <input type="checkbox"/> Other:			

Special Design Specifications

Overall Length:	Shank Diameter:
Pitch Diameter: Min: _____ Max: _____	Gage Limits: Go: _____ No Go: _____

Notes:

Continue notes on separate sheet if necessary



EMUGE Corp. • 1800 Century Drive • West Boylston, MA 01583-2121
 Phone (508)-595-3600 • Fax (508) 595-3650 • Toll Free (800) 323-3013 • www.emuge.com • emuge@emuge.com

Customer Information

Distributor Name:			End User Name:		
City:	State:	Zip:	Division:		
Phone: ()	Fax: ()	Street:			
Contact Person:			City:	State:	Zip:
Purchase Order #:			Phone: ()	Fax: ()	
Ship Via:			Contact Person:		
End User Reference #:			EMUGE Customer: <input type="checkbox"/> Yes <input type="checkbox"/> No	Needs Catalogs: <input type="checkbox"/> Yes <input type="checkbox"/> No	Needs Engineer: <input type="checkbox"/> Yes <input type="checkbox"/> No

Tapping Application

Tap Size:	Class of Fit:	<input type="checkbox"/> Through Hole	<input type="checkbox"/> Blind Hole	<input type="checkbox"/> Other:
Material:	Hardness:	Thread Length:	Thread Length:	
Tap Requirement: <input type="checkbox"/> Cutting <input type="checkbox"/> Forming <input type="checkbox"/> Either	Lubrication:	Drill Depth:		
Machine Tool Manufacturer/Type:	Tap Holder Manufacturer/Type:	Direction of Tapping: <input type="checkbox"/> Horizontal <input type="checkbox"/> Vertical		
Number of Taps in Setup:	Tap Make Presently Used:	Performance/Comments:		
Criteria for a Successful Test:				

EMUGE Tap Recommendation

Quantity:	EDP#:	Description:	List Price-\$/each:
Speed/SFM:	Tap Drill Size:	Lubrication:	Tap Holder:

EMUGE taps are very free cutting and will easily cut oversize threads if fed out of lead. For the best result, we recommend the use of an EMUGE Quick-Change Tap Holder with built-in tension, compression, and overload clutch features. Always utilize your holder's tension feature by programming spindle feed to 95-98% of the calculated feed rate. CALL AN EMUGE ENGINEER AT THE HOTLINE, 800-323-3013, IF YOU NEED TECHNICAL ASSISTANCE.

Test Result: Please Fax a Copy Immediately to EMUGE at (508) 595-3650

Tapped Holes: <input type="checkbox"/> Yes <input type="checkbox"/> No	Thread Quality: <input type="checkbox"/> Good <input type="checkbox"/> Poor	Tap Life: <input type="checkbox"/> Long <input type="checkbox"/> Short	Overall Performance: Scale 1 to 10	Tap Life: <input type="checkbox"/> Yes <input type="checkbox"/> No <input type="checkbox"/> Call Me
Comments:				Name: _____ Date: _____
				Phone: _____ Ext. _____ ()

Continue notes on separate sheet if necessary



EMUGE Corp. · 1800 Century Drive · West Boylston, MA 01583-2121
 Phone (508)-595-3600 · Fax (508) 595-3650 · Toll Free (800) 323-3013 · www.emuge.com · emuge@emuge.com

Customer Information

Distributor Name:			End User Name:		
City:	State:	Zip:	Division:		
Phone: ()	Fax: ()	Street:			
Contact Person:			City:	State:	Zip:
Purchase Order #:	Date:	Phone: ()	Fax: ()		
Ship Via:	To:	Contact Person:			
End User Reference #:	EMUGE Order #:	EMUGE Customer: <input type="checkbox"/> Yes <input type="checkbox"/> No	Needs Catalogs: <input type="checkbox"/> Yes <input type="checkbox"/> No	Needs Engineer: <input type="checkbox"/> Yes <input type="checkbox"/> No	

Workpiece Data

Drawing No.:		Title:			
Material:		Hardness:			
Type of Working:	<input type="checkbox"/> Turning	<input type="checkbox"/> Grinding	<input type="checkbox"/> Milling	<input type="checkbox"/> Control	
Operation:	<input type="checkbox"/> Roughing	<input type="checkbox"/> Semifinishing	<input type="checkbox"/> Finishing	<input type="checkbox"/> Other Operations	
Tolerance of Working Diameter:	Errors:	<input type="checkbox"/> Form	<input type="checkbox"/> Geometrical	<input type="checkbox"/> T.I.R.	<input type="checkbox"/> Other

Machine Data

Type of Machine:	RPM:	Spindlenose:	Direction of Rotation: <input type="checkbox"/> Left <input type="checkbox"/> Right		
Power Chucking:	Force:	Manual Chucking:			
Feed:	Cut Depth:	Speed-RPM:			
Other Information:					

Clamping Device

Chuck:	Mandrel:	Auto Load:	Manual Load:	Load Space:
Clamping Diameter:	Clamp Length:	Max. (Min.) Diameter Opening:	Stop: <input type="checkbox"/> Solid <input type="checkbox"/> Floating	
Other Information:				

Remarks/Sketch

--

Continue notes on separate sheet if necessary



EMUGE Corp. • 1800 Century Drive • West Boylston, MA 01583-2121
 Phone (508)-595-3600 • Fax (508) 595-3650 • Toll Free (800) 323-3013 • www.emuge.com • emuge@emuge.com

Customer Information

Distributor Name:			End User Name:		
Street:			Division:		
City:	State:	Zip:	Street:		
Contact Person:			City:	State:	Zip:
Phone: ()		Fax: ()		Contact Person:	
Purchase Order #:	Date:		Phone: ()		Fax: ()
Ship Via:	To:		EMUGE Customer: <input type="checkbox"/> Yes <input type="checkbox"/> No	Needs Catalogs: <input type="checkbox"/> Yes <input type="checkbox"/> No	Needs Engineer: <input type="checkbox"/> Yes <input type="checkbox"/> No
End User Reference #:	EMUGE Order #:				

Tapping Application

Tap Size:	Machine Tool Type & Mgr:
Class of Fit:	Spindle Connection:
Material:	Tapping Horizontal:
Hardness:	Tapping Vertical:
Through Hole:	Type of Feed:
Thread Length:	Tap Holder Type being Used:
Blind Hole:	Number of Holders in Set Up:
Thread Length:	Tap Presently Used:
Drill Depth:	
Cutting Tap:	
Forming Tap:	

Performance Comments:

Criteria for a Successful Test:

EMUGE Tap Holder Recommendation

Quantity:	EDP#:	Description:	List Price-\$/each:

EMUGE taps are very free cutting and will easily cut oversize threads if fed out of lead. For the best result, we recommend the use of an EMUGE Quick-Change Tap Holder with built-in tension, compression, and overload clutch features. Always utilize your holder's tension feature by programming spindle feed to 95-98% of the calculated feed rate. When using Full-Speed taps, Rigid Tapping use KSN-Softsynchro Tap Holders for best results. CALL AN EMUGE ENGINEER AT THE HOTLINE, 800-323-3013, IF YOU NEED TECHNICAL ASSISTANCE.

Test Result: Please Fax a Copy Immediately to EMUGE at (508) 595-3650

Comments:	Overall Performance: Scale 1 to 10	Additional Testing Required: <input type="checkbox"/> Yes <input type="checkbox"/> No <input type="checkbox"/> Call Me
		Name: _____ Date: _____
		Phone: _____ Ext. _____ ()

Continue notes on separate sheet if necessary



EMUGE Corp. • 1800 Century Drive • West Boylston, MA 01583-2121
 Phone (508)-595-3600 • Fax (508) 595-3650 • Toll Free (800) 323-3013 • www.emuge.com • emuge@emuge.com

Customer Information

Distributor Name:			End User Name:		
City:	State:	Zip:	Division:		
Phone: ()	Fax: ()	Street:			
Contact Person:			City:	State:	Zip:
Purchase Order #:	Date:	Phone: ()	Fax: ()		
Ship Via:	To:	Contact Person:			
End User Reference #:	EMUGE Order #:	EMUGE Customer: <input type="checkbox"/> Yes <input type="checkbox"/> No	Needs Catalogs: <input type="checkbox"/> Yes <input type="checkbox"/> No	Needs Engineer: <input type="checkbox"/> Yes <input type="checkbox"/> No	

Thread Milling Application

Thread Size:	Pitch:	Class of Fit:	Hole Type: <input type="checkbox"/> Through <input type="checkbox"/> Blind
Material:	Hardness:	Thread Length:	Drill Depth:
Machine Tool Manufacturer:	Position of Spindle: <input type="checkbox"/> Vertical <input type="checkbox"/> Horizontal		
Maximum RPM of Spindle:	Type of Controller:		
Coolant System: <input type="checkbox"/> Through Spindle <input type="checkbox"/> External	Type of Shank Connection:		

EMUGE Recommendation

Quantity:	EDP#:	Description:	List Price-\$/each:

CALL EMUGE's THREAD MILLING DEPARTMENT IF YOU NEED TECHNICAL ASSISTANCE.

Remarks/Sketch

Continue notes on separate sheet if necessary



A			B		
A0181000	Rc (BSPT)	117	B0100501	M	67
AU100501	UNC	36	B0100501	MF	85
AU100501	UNF	52	B0102000	LK-M	129
AU109101	UNC	36	B0109101	M	67
AU109101	UNF	52	B0109401	M	70
AU110501	M	81	B010J901	G	101
AU110501	MF	97	B010J901	M	68
AU110601	M	81	B010J901	MF	86
AU110601	MF	97	B010K101	G	101
AU203000	M	81	B010K101	M	69
AU203000	MF	97	B010K101	MF	87
AU203000	UNC	34	B010R501	M	62
AU203000	UNF	50	B0119401	M	70
AU203010	UNC "3B"	34	B011R501	M	63
AU203010	UNF "3B"	50	B016K101	G	101
AU203043	UNC "+.0035"	34	B016K101	M	69
AU203043	UNF "+.0035"	50	B016K101	MF	87
AU203044	UNC "+.0050"	34	B0203000	LK-M	129
AU203044	UNF "+.0050"	50	B0203000	STI-M	124
AU208400	M	80	B0203020	M "ISO 3/6G"	61
AU208400	MF	96	B0203030	M "7G"	61
AU208400	UNC	34	B0203100	LK-M	129
AU208400	UNF	50	B0208400	M	59
AU306001	UNC	35	B0208400	MF	82
AU306001	UNF	51	B0208900	M	59
AU306011	UNC "3BX"	35	B0208900	MF	82
AU306011	UNF "3BX"	51	B0208920	M "ISO 3/6G"	59
AU456001	UNC	35	B0208930	M "7G"	59
AU456001	UNF	51	B0208950	M-LH	60
AU456011	UNC "3BX"	35	B0208F01	M	71
AU456011	UNF "3BX"	51	B0208F01	MF	89
AU461000	M	80	B0208F21	M "6GX"	71
AU461000	MF	96	B020A601	M	71
AU461400	M	80	B020A601	MF	89
AU461400	MF	96	B020A621	M "6GX"	71
AU501400	M	80	B020C300	M	61
AU501400	MF	96	B020C300	STI-M	124
AU503000	M	81	B020K500	M	59
AU503000	MF	97	B020S800	M	63
AU503200	UNC	35	B020S800	STI-M	124
AU503200	UNF	51	B0306001	M	65
AU503210	UNC "3B"	35	B0309601	M	65
AU503210	UNF "3B"	51	B030J401	M	66
AU503243	UNC "+.0035"	35	B040V401	M	66
AU503243	UNF "+.0035"	51	B0453701	M	72
AU503244	UNC "+.0050"	35	B0456001	M	65
AU503244	UNF "+.0050"	51	B0459601	M	65
AU513500	UNC	37	B0461400	M	60
AU513500	UNF	53	B046L801	M	65
AU513510	UNC "3B"	37	B0501000	M	60
AU513510	UNF "3B"	53	B0501000	MF	83
AU513700	M	81	B0501020	M "ISO 3/6G"	60
AU513700	UNC	37	B0501030	M "7G"	61
AU513700	UNF	53	B0501050	M-LH	61
AU513710	UNC "3B"	37	B0501400	M	60
AU513710	UNF "3B"	53	B0501400	MF	83
AU921400	M	188	B0501420	M "ISO 3/6G"	61
AU921400	UNC	175	B0501430	M "7G"	61
			B0503000	M	62
			B0503200	M	62
			B0503200	MF	83
			B0503500	M	72
			B0503500	STI-M	125
			B0503700	M	73
			B050C300	M	62
			B050C300	MF	83
			B050C400	M	73
			B050S800	M	63
			B050S800	STI-M	124
			B0513500	LK-M	130
			B0513500	M	73
			B0513500	MF	90
			B0513500	STI-M	125
			B0513700	M	73
			B0513700	MF	90
			B0513720	M "ISO 3/6G"	73
			B0513720	MF "ISO 3/6G"	91
			B051C400	M	73
			B051C400	STI-M	125
			B051S800	M	64
			B0911000	M	182
			B0911400	LK-M	197
			B0911400	M	182
			B0911400	MF	190
			B0921000	M	182
			B0921400	LK-M	197
			B0921400	M	182
			B0921400	MF	190
			B0963701	M	72
			B0973700	M	73
			B0989501	M	64
			B098Q801	M	65
			B099C400	M	73
			B1069101	M	67
			B1069401	M	70
			B106R501	M	63
			B1088F01	M	71
			B1088F21	M "6GX"	71
			B108A601	M	71
			B108A621	M "6GX"	71
			B1099501	M	64
			B109R501	M	63
			B1577300	M	221
			B1579300	M	221
			B1667300	M	222
			B1950901	M	67
			B1950901	MF	85
			B1959101	M	67
			B1959401	M	70
			B195R501	M	63
			B1969401	M	70
			B1969501	M	64
			B196R501	M	63
			B1970100	M	182
			B2100501	M	79
			B2203000	M	79
			B2208900	M	78
			B220C300	M	79
			B2461000	M	78
			B2501000	M	78
			B2503000	M	79
			B250C300	M	79
			B3159401	M	74
			B3169401	M	74
			B3179401	M	74
			B3189401	M	74
			B3208F01	M	75
			B3258F01	M	75
			B3600F01	M	75
			B3650F01	M	75
			B4053701	M	72
			B4253701	M	72
			B438J401	M	66
			B4933200	M	221
			B4939300	M	221
			B5059500	M	187
			B5059500	MF	191
			B505Q800	M	187
			B505Q800	MF	191
			B5216F00	M	183
			B5217F00	M	183
			B521Q200	M	184
			B521W700	M	185
			B521Y700	M	184
			B521Z700	M	185
			B521Z700	MF	191
			B5236F00	M	183
			B5237F00	M	183
			B523Q200	M	185
			B523W700	M	185
			B523Y700	M	184
			B523Z700	M	185
			B523Z700	MF	191
			B523Z800	M	186
			B5296A00	M	183
			B5316A00	M	183
			B5317F00	M	183
			B531Q200	M	185



B531Y700	M	184	BU30J411	UNF "3BX"	42	BU501000	UNF	38	BU921000	UNF	176
B531Z700	M	186	BU35J411	STI-UNF "3BX"	122	BU501010	UNC "3B"	22	BU921400	UNC	170
B531Z800	M	186	BU35J411	UNC "3BX"	26	BU501010	UNF "3B"	38	BU921400	UNF	176
B5863200	M	222	BU35J411	UNF "3BX"	42	BU503200	UNC	23	BU929000	STI-UNC	193
B5991400	M	225	BU376F00	UNC	171	BU503200	UNF	39	BU929000	STI-UNF	194
B5999000	M	225	BU376F00	UNF	177	BU503210	UNC "3B"	23	BU92F000	UNC	173
BU088F01	UNC	28	BU377F00	UNC	171	BU503210	UNF "3B"	39	BU92F000	UNF	179
BU088F01	UNF	44	BU377F00	UNF	177	BU50C300	UNC	23	BU931400	LK-UNC	195
BU089300	UNC	23	BU37Q200	UNC	173	BU50C300	UNF	39	BU931400	LK-UNF	196
BU089300	UNF	39	BU37Q200	UNF	178	BU50C310	UNC "3B"	23	BU931400	UNC	170
BU100501	UNC	26	BU37Y700	UNC	172	BU50C310	UNF "3B"	39	BU931400	UNF	176
BU100501	UNF	42	BU37Y700	UNF	178	BU50C343	UNC "+.0035"	24	BU939000	UNC	170
BU109101	UNC	26	BU37Z700	UNC	173	BU50C343	UNF "+.0035"	40	BU939000	UNF	176
BU109101	UNF	42	BU37Z700	UNF	179	BU50C344	UNC "+.0050"	24	BU94C400	UNC	29
BU109401	UNC	27	BU386F00	UNC	171	BU50C344	UNF "+.0050"	40	BU94C400	UNF	45
BU109401	UNF	43	BU386F00	UNF	177	BU50C400	UNC	29	BU959101	UNC	27
BU10J901	UNC	27	BU387F00	UNC	171	BU50C400	UNF	45	BU959101	UNF	43
BU10J901	UNF	43	BU387F00	UNF	177	BU50S800	UNC	24	BU959401	UNC	27
BU203010	STI-UNC "3B"	119	BU38Q200	UNC	173	BU50S800	UNF	40	BU959401	UNF	43
BU203010	STI-UNF "3B"	121	BU38Q200	UNF	178	BU50S810	UNC "3B"	24	BU969401	UNC	27
BU206511	UNC "3BX"	25	BU38Z700	UNC	174	BU50S810	UNF "3B"	40	BU969401	UNF	43
BU206511	UNF "3BX"	41	BU38Z700	UNF	179	BU513500	LK-UNC	127	BU973701	UNC	29
BU208400	UNC	22	BU38Z800	UNC	174	BU513500	UNC	29	BU973701	UNF	45
BU208400	UNF	38	BU38Z800	UNF	180	BU513500	UNF	45	BU979000	UNC	22
BU208900	LK-UNC	126	BU396A00	UNC	171	BU513510	STI-UNC "3B"	120	BU979000	UNF	38
BU208F01	UNC	28	BU396A00	UNF	177	BU513510	STI-UNF "3B"	123	BU999400	UNC	30
BU208F01	UNF	44	BU39Z700	UNC	174	BU513700	UNC	29	BU999400	UNF	46
BU20A600	LK-UNC	127	BU39Z700	UNF	179	BU513700	UNF	45	BU99C400	UNC	30
BU20A600	LK-UNF	128	BU446A00	UNC	172	BU513710	STI-UNC "3B"	120	BU99C400	UNF	46
BU20A601	UNC	28	BU446A00	UNF	177	BU513710	STI-UNF "3B"	123	BU99C410	UNC "3B"	31
BU20A601	UNF	44	BU446F00	UNC	171	BU519400	UNC	30	BU99C410	UNF "3B"	47
BU20A611	UNC "3BX"	28	BU447F00	UNC	171	BU519400	UNF	46	BW10F000	UNC	173
BU20A611	UNF "3BX"	44	BU447F00	UNF	177	BU51C400	LK-UNC	127	BW10F000	UNF	179
BU20C300	UNC	23	BU44Q200	UNC	173	BU51C400	LK-UNF	128	BW138F01	UNC	31
BU20C300	UNF	39	BU44Q200	UNF	179	BU51C400	UNC	30	BW138F01	UNF	47
BU20C310	STI-UNC "3B"	119	BU44Y700	UNC	172	BU51C400	UNF	46	BW159401	UNC	31
BU20C310	STI-UNF "3B"	121	BU44Y700	UNF	178	BU51C410	STI-UNC "3B"	120	BW159401	UNF	47
BU20C310	UNC "3B"	23	BU44Z700	UNC	174	BU51C410	STI-UNF "3B"	123	BW169401	UNC	31
BU20C310	UNF "3B"	39	BU44Z700	UNF	180	BU51C410	UNC "3B"	30	BW169401	UNF	47
BU20C343	UNC "+.0035"	23	BU44Z800	UNC	174	BU51C410	UNF "3B"	46	BW179401	UNC	31
BU20C343	UNF "+.0035"	39	BU44Z800	UNF	180	BU51S810	STI-UNC "3B"	119	BW179401	UNF	47
BU20C344	UNC "+.0050"	23	BU451400	UNC	22	BU51S810	STI-UNF "3B"	121	BW208F01	UNC	31
BU20C344	UNF "+.0050"	39	BU451400	UNF	38	BU523701	UNC	29	BW208F01	UNF	47
BU20S800	UNC	24	BU453701	UNC	28	BU523701	UNF	45	BW553700	UNC	32
BU20S800	UNF	40	BU453701	UNF	44	BU533200	M	220	BW553700	UNF	48
BU20S810	STI-UNC "3B"	119	BU456001	UNC	25	BU533200	UNC	216	BW921400	UNC	170
BU20S810	STI-UNF "3B"	121	BU456001	UNF	41	BU533200	UNF	218	BW921400	UNF	176
BU219401	UNC	27	BU456011	STI-UNC "3BX"	120	BU539300	M	220	BW92F000	UNC	173
BU219401	UNF	43	BU456011	STI-UNF "3BX"	122	BU539300	UNC	216	BW92F000	UNF	179
BU263701	UNC	31	BU456011	UNC "3BX"	25	BU539300	UNF	218			
BU263701	UNF	47	BU456011	UNF "3BX"	41	BU573701	UNC	29			
BU293701	UNC	32	BU459600	LK-UNC	126	BU573701	UNF	45			
BU293701	UNF	48	BU459611	UNC "3BX"	25	BU591410	UNC "3BX"	223			
BU306001	UNC	25	BU459611	UNF "3BX"	41	BU591410	UNF "3BX"	224			
BU306001	UNF	41	BU497300	M	220	BU599010	UNC "3BX"	223			
BU306011	UNC "3BX"	25	BU497300	UNC	216	BU599010	UNF "3BX"	224			
BU306011	UNF "3BX"	41	BU497300	UNF	218	BU783200	UNC	217			
BU309600	LK-UNC	126	BU499300	M	220	BU783200	UNF	219			
BU309611	UNC "3BX"	25	BU499300	UNC	216	BU797300	UNC	217			
BU309611	UNF "3BX"	41	BU499300	UNF	218	BU797300	UNF	219			
BU30J411	UNC "3BX"	26	BU501000	UNC	22	BU921000	UNC	170			

C

C0100501	G	103
C0100501	M	67
C0100501	MF	85
C0101001	G	102
C0101001	NPSF	99
C0101001	NPSM / NPSC	98
C0101001	Rp (BSP)	100
C0101001	UNEF	54



C0102000	LK-M	129	C0501000	UNEF	54	C1088F01	M	71	C5217F00	M	183
C0109101	G	103	C0501020	M "ISO 3/6G"	60	C1088F01	MF	89	C5217F00	MF	190
C0109101	M	67	C0501030	M "7G"	61	C1088F21	M "6GX"	71	C521W700	M	185
C0109101	MF	85	C0501050	M-LH	61	C108A601	M	71	C521Z700	G	192
C0109401	M	70	C0501050	MF-LH	83	C108A601	MF	89	C521Z700	M	185
C0109401	MF	88	C0501400	G	103	C108A621	M "6GX"	71	C521Z700	MF	191
C010J901	G	104	C0501400	M	60	C109R501	M	63	C5236F00	M	183
C010J901	M	68	C0501400	MF	83	C109R501	MF	85	C5236F00	MF	191
C010J901	MF	86	C0501420	M "ISO 3/6G"	61	C1577300	M	221	C5237F00	M	183
C010R501	M	62	C0501430	M "7G"	61	C1579300	M	221	C5237F00	MF	190
C010R501	MF	84	C0503000	M	62	C1667300	M	222	C523W700	M	185
C0119401	M	70	C0503200	M	62	C1950901	M	67	C523Z700	G	192
C0119401	MF	88	C0503200	MF	83	C1950901	MF	85	C523Z700	M	185
C011R501	M	63	C0503500	M	72	C1959101	M	67	C523Z700	MF	191
C011R501	MF	84	C0503500	STI-M	125	C1959101	MF	85	C5317F00	M	183
C0183000	Rc (BSPT)	116	C0503700	M	73	C1959401	M	70	C5317F00	MF	190
C0203000	G	103	C050C300	G	103	C1959401	MF	88	C531Z700	M	186
C0203000	LK-M	129	C050C300	MF	83	C195R501	M	63	C5863200	M	222
C0203000	STI-M	124	C050C400	M	73	C195R501	MF	84	CU031410	UNC "3BX"	223
C0203020	M "ISO 3/6G"	61	C050S800	M	63	C1960901	G	104	CU031410	UNF "3BX"	224
C0203030	M "7G"	61	C0513500	G	105	C1969401	M	70	CU039010	UNC "3BX"	223
C0203100	LK-M	129	C0513500	LK-M	130	C1969401	MF	88	CU039010	UNF "3BX"	224
C0208400	G	102	C0513500	M	73	C196R501	M	63	CU088F01	UNC	28
C0208400	M	59	C0513500	MF	90	C196R501	MF	84	CU088F01	UNF	44
C0208400	MF	82	C0513500	NPSF	99	C2100501	M	79	CU089300	UNC	23
C0208900	G	102	C0513500	NPSM / NPSC	98	C2203000	M	79	CU089300	UNF	39
C0208900	M	59	C0513500	Rp (BSPP)	100	C2208900	M	78	CU100501	UN-8	56
C0208900	MF	82	C0513500	STI-M	125	C220C300	M	79	CU100501	UNC	26
C0208900	UNEF	54	C0513700	G	105	C2461000	M	78	CU100501	UNF	42
C0208920	M "ISO 3/6G"	59	C0513700	M	73	C2501000	M	78	CU109101	UNC	26
C0208920	MF "ISO 3/6G"	82	C0513700	MF	90	C2503000	M	79	CU109101	UNF	42
C0208930	M "7G"	59	C0513700	NPSF	99	C3159401	M	74	CU109401	UNC	27
C0208950	M-LH	60	C0513700	NPSM / NPSC	98	C3159401	MF	91	CU109401	UNF	43
C0208950	MF-LH	82	C0513700	Rp (BSPP)	100	C3169401	M	74	CU10J901	UNC	27
C0208F01	M	71	C0513720	M "ISO 3/6G"	73	C3169401	MF	91	CU10J901	UNF	43
C0208F01	MF	89	C0513720	MF "ISO 3/6G"	91	C3179401	MF	91	CU203010	STI-UNC "3B"	119
C0208F21	M "6GX"	71	C051C400	M	73	C3189401	MF	91	CU203010	STI-UNF "3B"	121
C020A601	M	71	C051C400	MF	90	C3208F01	M	75	CU206511	UNC "3BX"	25
C020A601	MF	89	C051C400	STI-M	125	C3208F01	MF	91	CU206511	UNF "3BX"	41
C020A621	M "6GX"	71	C0539401	M	77	C3258F01	MF	91	CU208400	UNC	22
C020C300	M	61	C0539401	MF	95	C3600F01	M	75	CU208400	UNF	38
C020C300	MF	83	C0803001	G	106	C3600F01	MF	92	CU208900	LK-UNC	126
C020C300	STI-M	124	C0803001	M	76	C3650F01	M	75	CU208F01	UNC	28
C020S800	M	63	C0803001	MF	93-94	C3650F01	MF	92	CU208F01	UNF	44
C020S800	STI-M	124	C0911400	G	192	C4053701	M	72	CU209300	UN-8	55
C0306001	M	65	C0911400	M	182	C4053701	MF	90	CU20A600	LK-UNC	127
C0309601	M	65	C0911400	MF	190	C4063701	M	77	CU20A600	LK-UNF	128
C030J401	M	66	C0921400	G	192	C4063701	MF	95	CU20A601	UNC	28
C0451000	G	102	C0921400	M	182	C4253701	M	72	CU20A601	UNF	44
C0451400	MF	82	C0921400	MF	190	C4253701	MF	89	CU20A611	UNC "3BX"	28
C0453701	M	72	C0963701	M	72	C4283701	M	77	CU20A611	UNF "3BX"	44
C0453701	MF	89	C0963701	MF	89	C4283701	MF	95	CU20C300	UN-8	55
C0456001	M	65	C0973700	M	73	C438J401	M	66	CU20C300	UNC	23
C0459601	M	65	C0973700	MF	90	C4933200	M	221	CU20C300	UNF	39
C0461000	G	102	C0983701	MF	89	C4939300	M	221	CU20C310	STI-UNC "3B"	119
C0461000	UNEF	54	C099C400	M	73	C5059500	M	187	CU20C310	STI-UNF "3B"	121
C0461400	M	60	C1069101	M	67	C5059500	MF	191	CU20C310	UNC "3B"	23
C0461400	MF	83	C1069101	MF	85	C505Q800	M	187	CU20C310	UNF "3B"	39
C0501000	G	103	C1069401	MF	88	C505Q800	MF	191	CU20C344	UNC "+.0050"	23
C0501000	M	60	C106R501	M	63	C5216F00	M	183	CU20C344	UNF "+.0050"	39
C0501000	MF	83	C106R501	MF	84	C5216F00	MF	191	CU20S800	UNC	24



F094... PCM ET1	614-615	GF161151 M, MF	274	GF163156 UN	266	GF175311 NPT (API-LP)	290
F094... PGR-GB	630	GF161156 M, MF	274	GF163211 G (BSP), Rp (BSPP), W	279	GF175311 NPTF	295
F211... SFM-NP	569-570	GF161211 M, MF	274	GF163211 LK-M, LK-MF	283	GF175316 NPT (API-LP)	290
F310... KSN/HD	527-536	GF161216 M, MF	274	GF163211 M, MF	271	GF175316 NPTF	295
F313... KSN/Synchro	542-545	GF162101 M, MF	272	GF163211 UN	266	GF175331 NPT (API-LP)	290
F315... Accessories	621	GF162106 M, MF	272	GF163216 G (BSP), Rp (BSPP), W	279	GF175331 NPTF	295
F315... Softsynchro®	484-504	GF162121 G (BSP), Rp (BSPP), W	280	GF163216 LK-M, LK-MF	283	GF175336 NPT (API-LP)	290
F322... Softsynchro®/PGR	505-506	GF162121 M, MF	272	GF163216 M, MF	271	GF175336 NPTF	295
F323... Accessories	622	GF162126 G (BSP), Rp (BSPP), W	280	GF163216 UN	266	GF175351 NPT (API-LP)	290
F323... KSN/HD/ER	537-539	GF162126 M, MF	272	GF165361 G (BSP), Rp (BSPP), W	281	GF175351 NPTF	295
F324... KSN/HD/PGR	540-541	GF162131 G (BSP), Rp (BSPP), W	280	GF165361 M, MF	275	GF175356 NPT (API-LP)	290
F330... Adapter Shanks	604-605	GF162131 M, MF	272	GF165366 G (BSP), Rp (BSPP), W	281	GF175356 NPTF	295
F330... Assembly Wrenches	607	GF162136 G (BSP), Rp (BSPP), W	280	GF165366 M, MF	275	GF193101 NPT	289
F330... Coolant Tubes	606	GF162136 M, MF	272	GF165371 G (BSP), Rp (BSPP), W	281	GF193101 NPTF	294
F330... KSN	512-526	GF162151 G (BSP), Rp (BSPP), W	280	GF165371 M, MF	275	GF193101 Rc (BSPT)	298
F347... KSN/MQL	559, 561	GF162151 M, MF	272	GF165376 G (BSP), Rp (BSPP), W	281	GF193106 NPT	289
F348... KSN/MQL	560	GF162156 G (BSP), Rp (BSPP), W	280	GF165376 M, MF	275	GF193106 NPTF	294
F349... Softsynchro®/MMS	548, 550	GF162156 M, MF	272	GF165381 G (BSP), Rp (BSPP), W	281	GF193106 Rc (BSPT)	298
F350... Accessories	622	GF162211 G (BSP), Rp (BSPP), W	280	GF165381 M, MF	275	GF193111 NPT	289
F350... EM-L/ER/IKZ	597	GF162211 M, MF	272	GF165386 G (BSP), Rp (BSPP), W	281	GF193111 NPTF	294
F351... Softsynchro®/MMS	549	GF162216 G (BSP), Rp (BSPP), W	280	GF165386 M, MF	275	GF193111 Rc (BSPT)	298
F354... Softsyn.® Modular/IKZ	489	GF162216 M, MF	272	GF165391 G (BSP), Rp (BSPP), W	281	GF193116 NPT	289
F355... Adapters	607	GF162311 M, MF	273	GF165391 M, MF	275	GF193116 NPTF	294
F355... Coolant Tubes	606	GF162311 UN	267	GF165396 G (BSP), Rp (BSPP), W	281	GF193116 Rc (BSPT)	298
F355... Length Adjustm. Screws	608	GF162316 M, MF	273	GF165396 M, MF	275	GF193131 NPT	289
F355... Softsyn.® Mod/MQL	552-557	GF162316 UN	267	GF172101 NPSF	282	GF193131 NPTF	294
F356... EM/PGR/IKZ	598	GF162321 M, MF	273	GF172106 NPSF	282	GF193131 Rc (BSPT)	298
F374... Accessories	621	GF162321 UN	267	GF172111 NPSF	282	GF193136 NPT	289
F374... Speedsyn.® Mod/IKZ	508-509	GF162326 M, MF	273	GF172116 NPSF	282	GF193136 NPTF	294
F375... Length Adjustm. Screws	609	GF162326 UN	267	GF172131 NPSF	282	GF193136 Rc (BSPT)	298
F375... Speedsyn.® Mod/MQL	510, 558	GF162331 M, MF	273	GF172136 NPSF	282	GF193151 NPT	289
F449... EM/MQL	562	GF162331 UN	267	GF172151 NPSF	282	GF193151 NPTF	294
F450... EM-Z/MQL	563-564	GF162336 M, MF	273	GF172156 NPSF	282	GF193151 Rc (BSPT)	298
F656... EM-S	600	GF162336 UN	267	GF173101 NPT	288	GF193156 NPT	289
F658... EM-LS	601	GF162351 M, MF	273	GF173101 NPTF	293	GF193156 NPTF	294
FZ111300	136	GF162351 UN	267	GF173101 Rc (BSPT)	297	GF193156 Rc (BSPT)	298
FZ111310	137	GF162356 M, MF	273	GF173106 NPT	288	GF195301 NPT (API-LP)	291
FZ111900	132, 134	GF162356 UN	267	GF173106 NPTF	293	GF195301 NPTF	296
FZ111910	133, 135	GF163101 M, MF	271	GF173106 Rc (BSPT)	297	GF195306 NPT (API-LP)	291
FZ112000	139	GF163106 M, MF	271	GF173111 NPT	288	GF195306 NPTF	296
FZ112030	139	GF163121 LK-M, LK-MF	283	GF173111 NPTF	293	GF195311 NPT (API-LP)	291
FZ112100	139	GF163121 M, MF	271	GF173111 Rc (BSPT)	297	GF195311 NPTF	296
FZ112110	139	GF163121 UN	266	GF173116 NPT	288	GF195316 NPT (API-LP)	291
FZ112320	132	GF163126 LK-M, LK-MF	283	GF173116 NPTF	293	GF195316 NPTF	296
FZ112330	133	GF163126 M, MF	271	GF173116 Rc (BSPT)	297	GF195331 NPT (API-LP)	291
FZ112600	136	GF163126 UN	266	GF173131 NPT	288	GF195331 NPTF	296
FZ112610	137	GF163131 G (BSP), Rp (BSPP), W	279	GF173131 NPTF	293	GF195336 NPT (API-LP)	291
FZ131500	138	GF163131 LK-M, LK-MF	283	GF173131 Rc (BSPT)	297	GF195336 NPTF	296
FZ131510	138	GF163131 M, MF	271	GF173136 NPT	288	GF195351 NPT (API-LP)	291
FZ191900	131	GF163131 UN	266	GF173136 NPTF	293	GF195351 NPTF	296
		GF163136 G (BSP), Rp (BSPP), W	279	GF173136 Rc (BSPT)	297	GF195356 NPT (API-LP)	291
		GF163136 LK-M, LK-MF	283	GF173151 NPT	288	GF195356 NPTF	296
		GF163136 M, MF	271	GF173151 NPTF	293	GF243701 M, MF	305
		GF163136 UN	266	GF173151 Rc (BSPT)	297	GF243706 M, MF	305
		GF163151 G (BSP), Rp (BSPP), W	279	GF173156 NPT	288	GF253101 M, MF	305
		GF163151 LK-M, LK-MF	283	GF173156 NPTF	293	GF253106 M, MF	305
		GF163151 M, MF	271	GF173156 Rc (BSPT)	297	GF253701 M, MF	305
		GF163151 UN	266	GF175301 NPT (API-LP)	290	GF253701 UNC, UNF	302
		GF163156 G (BSP), Rp (BSPP), W	279	GF175301 NPTF	295	GF253706 M, MF	305
		GF163156 LK-M, LK-MF	283	GF175306 NPT (API-LP)	290	GF253706 UNC, UNF	302
		GF163156 M, MF	271	GF175306 NPTF	295	GF26A129 M, MF	308

G



GF26A129 UNC	304	GF432201 UNC	236	GF663207	334	GZ340050	320
GF26A129 UNF	304	GF432201 UNF	237	GF663305	334	GZ340101	322
GF26A729 M, MF	308	GF432206 M	238	GF663307	334	GZ340112	324
GF26A729 UNC	304	GF432206 MF	240	GF663405	334	GZ340121	322
GF26A729 UNF	304	GF432206 STI-M	241	GF663407	334	GZ340143	326
GF273106 M, MF	307	GF432206 UNC	236	GF732257 M, MF	248	GZ340153	326
GF273106 UNC	303	GF432206 UNF	237	GF732257 UNC	244	GZ340200	320
GF273106 UNF	303	GF432251 M	239	GF732257 UNF	246	GZ340201	322
GF273701 M, MF	306	GF432256 M	239	GF733208 M, MF	249	GZ340202	324
GF273706 M, MF	307	GF442201 M	238	GF733208 UNC	245	GZ340203	326
GF273706 UNC	303	GF442201 UNC	236	GF733208 UNF	247	GZ340211	322
GF273706 UNF	303	GF442206 M	238	GF753276 M, MF	250	GZ340212	324
GF283129 M, MF	309	GF442206 UNC	236	GF927126 M	278	GZ340221	322
GF283729 M, MF	309	GF442251 M	239	GFB35101 M, MF	276	GZ340231	322
GF322101 G	260	GF442256 M	239	GFB35101 MF	277	GZ341000	320
GF322101 M	256	GF603111 G (BSP), BSW, BSF, W	313	GFB35106 M, MF	276	GZ341001	322
GF322101 MF	258	GF603111 M, MF	313	GFB35106 MF	277	GZ341012	324
GF322101 UNC	252	GF603111 UN	313	GFB35106 UNC, UN	268	GZ341021	322
GF322101 UNF	254	GF603117 G (BSP), BSW, BSF, W	313	GFB35106 UNF, UN	269	GZ341032	324
GF322106 G	260	GF603117 M, MF	313	GFR15106 M	270	GZ341040	320
GF322106 M	256	GF603117 UN	313	GFR15106 UNC	264	GZ341050	320
GF322106 MF	258	GF603147 G (BSP), BSW, BSF, W	314	GFR15106 UNF	265	GZ341101	322
GF322106 UNC	252	GF603147 M, MF	314	GFR35106 UNC	264	GZ341112	324
GF322106 UNF	254	GF613121 G (BSP), BSW, BSF, W	315	GFR35106 UNF	265	GZ341121	322
GF332101 G	260	GF613121 M, MF	315	GFS13706 UNC, UNF	300	GZ341131	322
GF332101 M	256	GF613127 G (BSP), BSW, BSF, W	315	GFS23106 STI-UNC	310	GZ341143	326
GF332101 MF	258	GF613127 M, MF	315	GFS23106 UNC, UNF	300	GZ341153	326
GF332101 UNC	252	GF641007 M, MF	321	GFS23706 STI-UNC	310	GZ341200	320
GF332101 UNF	254	GF641107 M, MF	323	GFS23706 UNC, UNF	300	GZ341201	322
GF332106 G	260	GF641207 M, MF	325	GFS33106 UNC, UNF	300	GZ341202	324
GF332106 M	256	GF641307 M, MF	327, 329	GFS83106 UNC, UNF	301	GZ341211	322
GF332106 MF	258	GF641407 M, MF	331	GFS83706 UNC, UNF	301	GZ341221	322
GF332106 UNC	252	GF643005 G (BSP), BSW, BSF, W	321	GFT53106 NPT	286	GZ341231	322
GF332106 UNF	254	GF643005 UN, M, MF	321	GFT53116 NPT	286	GZ343003	326
GF333101 LK-M	261	GF643007 G (BSP), BSW, BSF, W	321	GFT53136 NPT	286	GZ343014	330
GF333106 LK-M	261	GF643007 UN, M, MF	321	GFT53156 NPT	286	GZ343103	326
GF335101 UNC	253	GF643105 G (BSP), BSW, BSF, W	323	GFT53A06 NPT	287	GZ343114	330
GF335101 UNF	255	GF643105 UN, M, MF	323	GFT53A16 NPT	287	GZ344003	326
GF335106 UNC	253	GF643107 G (BSP), BSW, BSF, W	323	GFT53A36 NPT	287	GZ344014	330
GF335106 UNF	255	GF643107 NPT	323	GFT53AA6 NPT	287	GZ344024	330
GF335126 M	257	GF643107 UN, M, MF	323	GFT8B209 NPT (API-LP)	292	GZ344035	332
GF335126 MF	259	GF643205 G (BSP), BSW, BSF, W	325	GFT8B219 NPT (API-LP)	292	GZ344045	332
GF342101 M	256	GF643205 UN, M, MF	325	GFT8B239 NPT (API-LP)	292	GZ344103	326
GF342101 UNC	252	GF643207 G (BSP), BSW, BSF, W	325	GFT8B259 NPT (API-LP)	292	GZ344114	330
GF342106 M	256	GF643207 NPT	325	GZ301110	312	GZ344124	330
GF342106 UNC	252	GF643207 UN, M, MF	325	GZ301130	312	GZ344203	326
GF422201 M	238	GF643305 G (BSP), BSW, BSF, W	327, 329	GZ301140	312	GZ344204	330
GF422201 MF	240	GF643305 UN, M, MF	327, 329	GZ301310	312	GZ346003	326
GF422201 STI-M	241	GF643307 G (BSP), BSW, BSF, W	327, 329	GZ301320	312	GZ346013	326
GF422201 UNC	236	GF643307 UN, M, MF	327, 329	GZ301330	312	GZ346024	330
GF422201 UNF	237	GF643405 G (BSP), BSW, BSF, W	331	GZ301340	312	GZ348103	326
GF422206 M	238	GF643405 UN, M, MF	331	GZ303010	314	GZ348114	330
GF422206 MF	240	GF643407 G (BSP), BSW, BSF, W	331	GZ309010	313	GZ349010	321
GF422206 STI-M	241	GF643407 UN, M, MF	331	GZ309020	313, 314	GZ349011	323
GF422206 UNC	236	GF643505 UN, M, MF	333	GZ309210	314	GZ349012	325
GF422206 UNF	237	GF643507 UN, M, MF	333	GZ311330	315	GZ349013	327, 329
GF422251 M	239	GF663005	334	GZ319020	315	GZ349014	331
GF422256 M	239	GF663007	334	GZ319060	315	GZ349015	333
GF432201 M	238	GF663105	334	GZ340000	320	GZ349020	321
GF432201 MF	240	GF663107	334	GZ340001	322	GZ349021	323
GF432201 STI-M	241	GF663205	334	GZ340012	324	GZ349022	325



Warranty

EMUGE Corp. warrants to original equipment manufacturers, distributors and industrial users of its products that each new product manufactured or supplied by EMUGE Corp. shall be free from defects in material and workmanship. EMUGE Corp.'s obligation under this warranty is limited to furnishing without additional charge a replacement, or at its option, repairing or issuing credit for any product which shall within one year from the date of sale be returned freight prepaid to the location designated by an EMUGE Corp. representative and which upon inspection is determined by EMUGE Corp. to be defective in materials or workmanship. Complete information as to operating conditions, machine setup, and application of cutting fluid should accompany any product returned for inspection. The provisions of this warranty shall not apply to any EMUGE Corp. product which has been subjected to misuse, improper operation conditions, machine setup or application of cutting fluid or which has been repaired or altered if such repair or alteration in the judgment of EMUGE Corp. would adversely affect performance of the product. This warranty is in lieu of all other warranties, express or implied, including any implied warranty of merchantability or fitness for a particular purpose. EMUGE Corp. shall have no liability or responsibility on any claim of any kind, whether in contract, tort or otherwise, for any loss or damaging arising out of, connected with, or resulting from the manufacture, sale, delivery or use of any product sold hereunder, in excess of the cost of replacement or repair as provided herein. In no event shall EMUGE Corp. be liable for any special, incidental or consequential damages. EMUGE Corp. makes no other warranty, express or implied, except as set forth above, and EMUGE Corp. neither assumes nor authorizes any other person or entity to assume for it any other obligation or liability in connection with any of its products.

Warning

- Any cutting tool may break or shatter if improperly used. Government regulations require use of safety glasses and other appropriate safety equipment at all times in the vicinity of use.
- Grinding of taps or dies may produce hazardous dust and should only be done under established safety guidelines.
- Tapping fluids may contain hazardous materials. Always consult the appropriate material safety data sheets before the use of any EMUGE products.

Notice

Because we are constantly engaged in a program of product improvement, tool specifications are subject to change at any time. All EMUGE Corp. terms and conditions are subject to change without notice.



EMUGE Corp.

 1800 Century Drive
West Boylston, MA 01583-2121
USA

 +1-508-595-3600, +1-800-323-3013 (Toll-Free)

 +1-508-595-3650

 info@emuge.com

 www.emuge.com